

METHODS OF WORK _____

Finish Samples

Every woodworker and wood finisher has experienced the frustration of trying to describe the peculiar merits of a particular finish to his customers or to his fellow craftsmen. Words fail because the essence of a fine finish is sensory—one appreciates it through the fingertips and the eyes. My answer is a collection of finish samples, which I have been developing and refining for the past three years. Constant questions from my refinishing students and patrons forced me to develop it as a tangible answer; my system should work equally well for the amateur craftsman or the professional.

Start with 40 or more pieces of wood about 1/2 by 4-1/2 by 9 inches, a convenient size for handling and storage, yet large enough to display the finish. Mahogany is a suitable wood because it is so often encountered in old furniture that needs refinishing. My collection includes both plain-sawed and quarter-sawed wood, and I keep a piece of raw wood as a control. It's a good idea to bleach a couple of pieces too; they will come in handy later on.

All the pieces should be carefully sanded at the same time, following your usual techniques, to ensure uniformity. I use



garnet paper and start with 100 grit until all the milling marks are gone, then I sand with 150 grit before filling. I apply paste wood filler to one face, edge and end of the sample to illustrate the contrasts that will appear in the finished piece, and then sand to 280 grit. When all the wood is prepared, it is ready to receive the finishes you most often work with. The samples can be set aside and worked up one at a time, or you can do intensive work to build up a nucleus of the more common finishes and add more, or play with variables, later on.

The possible variables include finishes on raw woods, finishes over various sealers, stains, fillers and finishes over other finishes. Additives in finish materials, such as driers and stains, produce interesting results. Several blocks of wood, all finished with the same material and then rubbed out with abrasive flours to show the development of a polished surface, say more than words ever could. Finally, finish samples can be subjected to stresses such as alcohol, chemicals, water and burns to test your efforts.

It takes many hours to produce a fine set of finished specimens, but the extended exercise is worth the effort. It

leads to conformity in each finished product and makes the finisher familiar with a wide range of materials and their application. The result is a unique educational tool that can be shared with others and always expanded. It will last forever, and it saves a lot of talking.

—David Adamusko, Alexandria, Va.

Sliding Dovetail Saw

To make a sliding dovetail saw you will need a piece of hardwood (maple, beech or fruitwood) 1 x 5-1/2 x 13 in. and two flat-head 3/16 x 1-in. bolts with tee-nuts. The blade can

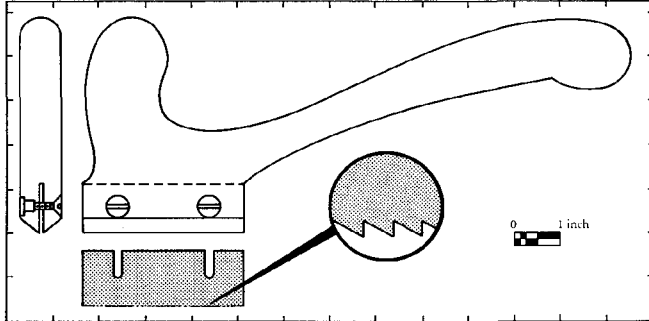

be an old band saw or bow saw blade. It should have 10 points to the inch, although 8 will do. I use a rip saw blade, which I find cuts better and faster than a crosscut. The slots allow the blade to be set to the desired depth.

—Tage Frid

English Plane

There are thousands of old Stanley wood-bottom planes to be had at antique shows, flea markets and garage sales—usually for under \$10. With a little work, most of these can be put back into service. I usually cut 1/4 in. from the bottom of the plane, then epoxy a new sole of lignum vitae or rosewood in place, and then recut the mouth.

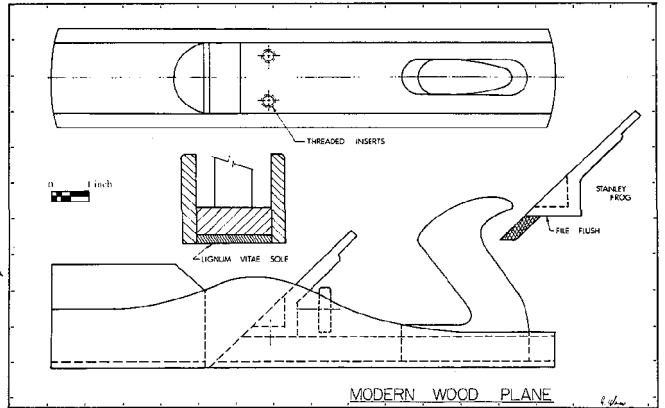

Last year I saw a beautiful English plane that was not available here, so I made one like it. The heart of the plane is a modified Bailey frog mechanism, which provides the standard metal plane adjusting features. The frog could be removed from an old metal plane or purchased as a replacement part. It was modified by filing away the two

METHODS OF WORK (continued)

tongues at the base, then mounted in the wooden body (*Fine Woodworking*, Winter 1975) by setting two threaded inserts for bolts.

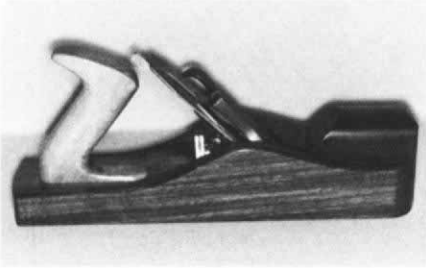

Depending on the thickness of the sole, it might be necessary to modify the cap iron by retapping the screw hole and adding a second square hole for the depth-adjusting lever. I wanted the plane to be as colorful as possible so I used lignum vitae and walnut for the sole, purple heart for the sides, rosewood for the front and beech for the handle.

—Allen Weiss, Queens, N. Y.

Bench-Top Clamps

My bench has two rows of holes along the front and back edges. These

accommodate lengths of 3/4-in. pipe, standing vertically, each fitted with extension clamps of the Sears variety. Two or more clamps may thus be mounted in conjunction with cross members for clamping frames, boxes, chests or chairs in gluing position. Four or more clamps form a light-duty veneer press against the bench top.

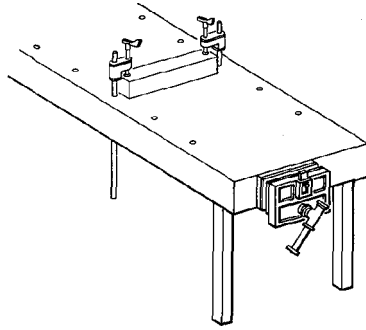

The advantage of this gluing method is that the work is always held true and square because the bench is a flat reference surface.

The holes for the pipe clamps are spaced about 8 in. apart. A crosspiece between two clamps may be used as a bench stop in conjunction with the stop

on the tail vise, thereby holding long pieces of wood on the bench.

—Harold F. Lathrop, Milan, Ill.

Vee-Block for Resawing

I have had only mixed results using a rip fence on a band saw for resawing wood. Unless the blade teeth are perfectly set and sharpened, the blade tends to drift even though the board is firmly held against the fence. This

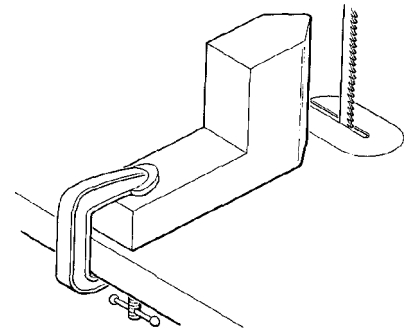

drifting can cause the wood to bind and will leave a wavy surface.

The blade's tendency to drift can be sidestepped by using a vee-edged block

attached to the band saw table, as in the drawing. The block is located so that its rounded point is even with the toothed edge of the blade, and at the desired thickness of board from the blade. The block must be carefully made so that the radius at the vee is square to the face of the blade.

To use this approach the board to be resawed is scribed along its edge at the desired thickness. The vee-block provides a guide to hold the side of the board parallel to the blade. The board is fed into the blade with the operator free to swing the unsawed end to counter the drift. The surface will still need to be planed before it is of furniture quality, but this setup is much easier, faster and more accurate than using a rip fence.

—M. G. Rekoﬀ Jr., Minneapolis, Minn.

Clamping Splined Miters

The splined miter, an excellent joint for plywood carcasses, can be difficult to glue up. One way is to save the scrap when the miters are sawed, and use it for clamping blocks. Cut the mitered

scrap into strips and glue it directly to the carcass on the outside of each joint. Spread glue lightly on the scrap strips, not on the carcass itself. Try to use scrap with the grain running crosswise as it will be easier to remove.

This creates two parallel surfaces to apply clamping pressure directly across

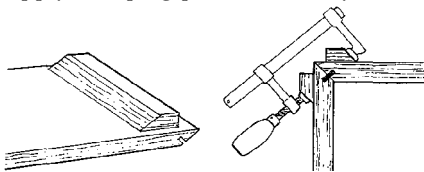

the joint. No large bar clamps, which usually bow the carcass and distort the joint, will be needed. The joints may be assembled one at a time or all at once, depending on the size and geometry of the work.

After assembly the scrap can be chiseled and planed away and any glue residue scraped and sanded off. Most plies are so weak when cut into narrow strips that a sharp hammer blow will break the waste, leaving only a few shreds of face veneer to clean away from the work.

—John Kelsey

Ball Plane

I was recently asked to make a double-curved "ball plane" with which to smooth a laminated cherry sphere five feet in diameter.

The wooden sole of the plane is curved throughout its length and width, combining the traditional sole design of the wheelwright's compass plane and the joiner's hollow molding plane. I followed the plane-making methods set out in your first issue to make the basic plane, which is 10 in. long, by 2-7/8 in. wide and high. The blade angle is 47 degrees and the iron is a 51-mm (2-in.) "Record" tungsten-vanadium iron and cap set.

After making the block, a template was used to trace a section of a five-foot diameter circle on the sole. The sole was then chiseled to within 1/16 in. of true, and a flat scraper was used to finally reach the true line. This operation formed the curve throughout the sole's length. The plane bottom was scraped slightly hollow so it would function like a Japanese smoothing plane, hitting the work at three points only: front,

METHODS OF WORK (continued)

back and cutting iron. This helped level the ball in every direction. A spokeshave and another scraper, ground and shaped to the same 5-ft. arc, were used to curve the sole across its width.



The iron was then roughly ground to the same curved line and finally brought to the exact curve with a sequence of increasingly fine sharpening slips.

I used white beech for the sole and the main part of the block, oak for the top plate and wedge, walnut for the front horn and cherry for the rear palm handle. The handles were shaped to fit the hand whether pulling or pushing. The entire plane weighs only two pounds, an important consideration since many days were spent bringing the sphere to within 1/4 in. of a five-foot diameter.

Eduardo A. Rumayor, Bronx, N. Y.

ADDENDA, ERRATA, ETC.

On the **workbench drawings** in the fall issue, in Piece 11 (p. 45) the hole for the bench screw should be 1-3/4 inches up from the bottom, not the 2 inches indicated. And the missing type on Piece 10 (p. 43) should read 1-3/4 inches.... The reversing third drum for the **stroke sander** in the summer issue is no longer available as a stock item. George Mooradian says he'll make some up if he gets enough orders. Otherwise, he recommends his off-the-shelf Model 1000 special extended shaft mandrel as a substitute... **We invite our readers to submit items** for our new Methods of Work section, as well as articles and book reviews. But on the articles, try the idea out on us first. Our payment upon publication is \$100 per magazine page, prorated, with a minimum of \$25 per item... **Art Credits** Drawings by Image Area.... **Picture credits:** 28, 29, Bruce Mervine ; 60, 61 Charles Hall, Rodney Vowell.

METHODS OF WORK _____

A router plane

You can build your own routing plane that will work as well as a commercial one for the cost of a cheap offset screwdriver and a U-bolt. The cutting irons are ground from the screwdriver bits, a blade about 1/4 in. wide at one end, and a

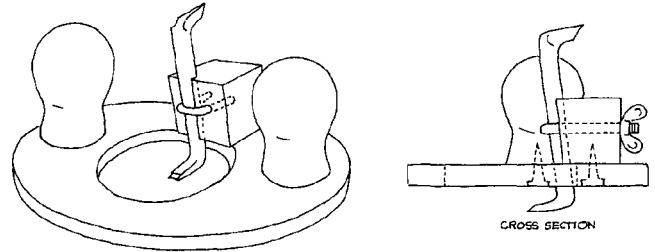

narrow plow at the other. The blades sit almost flat to the work, like paring chisels. Relief under the heel of the blade is obtained by making the blade holder with a tilted face.

Dimensions and shape can be suited to the builder's fancy and to the materials at hand. The illustrated design is simple enough to be produced in a single evening at the workbench.

—*Van Caldwell, Cincinnati, Ohio*

Natural stains

All my stains are made from natural materials—nuts, wood and plants. They are very true in color. First you must gather material for the color you desire. The dry husks of black walnut shells give a deep brown tone. Dry beechnut husks make a deep yellow tan, plug tobacco an antique yellow, red swamp cedar chips a reddish-brown. I have used other nuts and woods; I suggest experimenting with whatever is available to you. My mother, part Indian, suggested many natural materials to use for stains, and so was a great help in my search. The Indians used a homemade lye, but I found an easier answer—non-sudsing ammonia.

Place the materials to be leached in a jar, pour in the ammonia until the material is covered, and let sit. Black walnuts absorb the liquid, so it may be necessary to add more ammonia to keep the husks saturated. How long you soak the material affects the deepness of the color. Tobacco leaches out in a week. Black walnut shells still have color after a month and can sometimes be washed and used for a second batch.

After the tone is right, strain the juice off through a nylon stocking into a clean jar. (Don't use cans, because they will rust.) Leave the jar open for several days until most of the ammonia smell has dissipated. It can be used right away, but is strong-smelling! For a lighter tone, dilute with water; for a darker stain, let the liquid evaporate. Because the stain is water-based, the wood will need light rubbing after application. The stain works well under oil or varnish finishes.

Be sure to use non-sudsing ammonia. Sudsing ammonia will carry the color to the top with the suds.

—*C. H. Dimmick, Sparta, N.J.*

Using chalk

When working the darker woods like walnut or rosewood, pencil lines and even scribe marks have a distressing way of fading into the vagaries of color and grain. The woodworker

METHODS (continued)

can waste a lot of time relocating his mark, or worse, cutting what he thought was his mark, only to discover it to be a color change inches from the desired point. A piece of chalk can be a great help. The faintest scribe mark, dusted with yellow or white chalk, jumps out dramatically and makes accurate cutting a certainty. One can also use chalk for setting out dimensions on lumber prior to rough-sizing. If you are like me, and indecision is a habit, you can easily brush off the chalk.

—*Christopher Murray, Richmond, Va.*

Darkening glue lines

Glue lines of polyvinyl and aliphatic resin glues (white and yellow) can be darkened with tincture of iodine. This turns the glue a dark purple, perfect for walnut and dark mahogany. It should be applied after wet-sanding as it does not penetrate deeply, but it does go through oil nicely. I have also had good results using it under lacquer.

—*Richard S. Newman, Rochester, N. Y.*

Raising dents

To eliminate or reduce dents in wood use a soldering iron, a natural-fiber, smooth-finish cloth folded to a point, water, and discretion.

Wet the dent, allowing the crushed fibers to soak up the water. Squeeze excess water out of the cloth. Bring the iron up to the boiling point, but not to full heat. Test the wet cloth until it steams. Press the wet cloth into the dent with

METHODS (continued)

the hot iron for as long as steam is still produced. Repeat, if necessary, until no further rising occurs. You cannot burn the wood as long as the cloth is wet, so press the iron for brief intervals and be sure the cloth is continually wet. This should be done only on raw wood; if there is finish on the piece, remove the finish first.

Raise the dent before final planing or scraping. Otherwise, the dent may rise above the planed surface. Make one or two passes with a plane at its finest setting after raising the dent. An older method is to use a household iron. This is cumbersome and also raises the grain in the undamaged wood around the dent.

This technique works as long as the dented fibers have been crushed and not torn.

—Henry T. Kramer, Rye, N. Y.

Cleaning saw blades

Oven cleaner works very well for removing pitch from bits and saw blades without harming the steel. A clean cutting surface stays sharp longer, gives better results, taxes the motor less and makes for safer use of the tool.

—Chuck Oliver, Fremont, N. H., and
George Eckhart, Kenosha, Wis.

Making clamps

For many people who aren't professional cabinetmakers, wooden clamps are in the luxury-tool class. Good commercially-made handscrews cost at least \$10 in the 8-in. size. Materials to make one cost less than \$2.

Make the jaws from maple or another dense hardwood. The 1/2-in. holes must be carefully drilled square to the jaw surface and the same distance apart. The spindles are 5/16-in. steel bar. Thread one end 5/16-18 right-handed, and the opposite end 5/16-18 left-handed. Make the 5-in. long

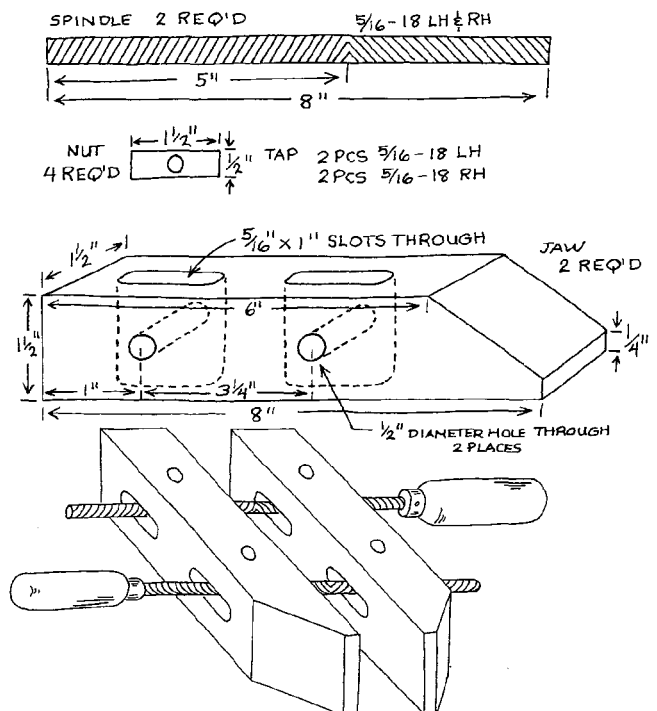

METHODS (continued)

thread right-handed on one spindle, and left-handed on the other. The 3-in. thread is also reversed. Make the nuts from 1/2-in. round bar. Be sure the tapped holes are square to the axis of the bar. Small file handles will work well if you don't have a lathe. Drill through the ferrule and spindle and insert a small pin after assembly.

—Richard E. Price, Seattle, Wash.

Wooden box hinge

This box hinge is easy to make and provides a built-in lid stop. First fit the hinge pieces to the lid. A short sliding dovetail is probably the best joint. Set the lid on the box and scribe the outline of the hinge pieces on the back. Cut the

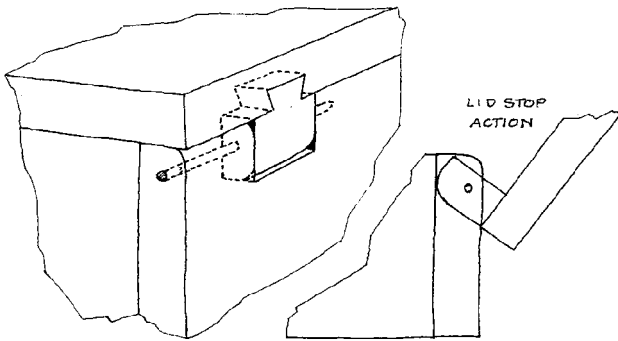

slots in the back. After measuring pin location drill pinholes in from the side of the box with the lid in place. Redrill the

METHODS (continued)

holes through the hinge pieces for easier operation. Install the pins. An ordinary nail works well. The hinge and the back edge of the box should be slightly rounded off.

—Jim Richey, Houston, Tex.

Cutting circles

A good method for cutting perfect circles on a band saw: Take a strip of plywood or chipboard about a foot wide and several feet long. Divide it lengthwise with a line. Lay it on the band-saw table and cut a slot from one edge to the center line. Along the line from the slot, mark off the radii of the circles you wish to cut and drill pilot holes. Countersink these holes on the back of the board and insert a wood screw in any hole. Mark the screw, remove it and grind it so only a point protrudes. Now you can put the screw in the appropriate

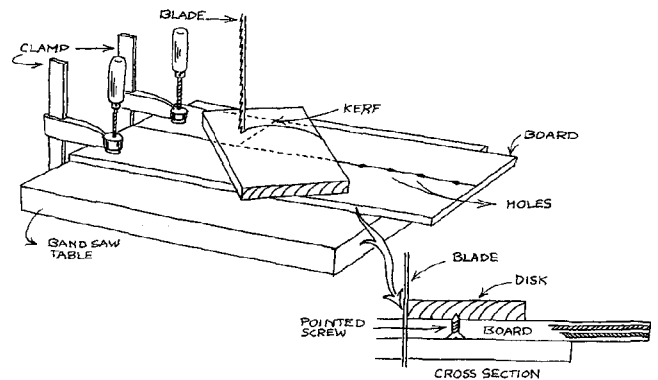

hole, clamp the board to the band-saw table, and pivot the blank you wish to cut on the protruding point. You can finish the edge of the circle with a similar setup on a disc or belt sander.

—Larry Green, Bethel, Conn.

Repairing mallets

Wooden carving mallets tend to check unless well cared for. I solve this annoying problem by whipping a line around the face of a badly checked mallet. I use heavyweight string

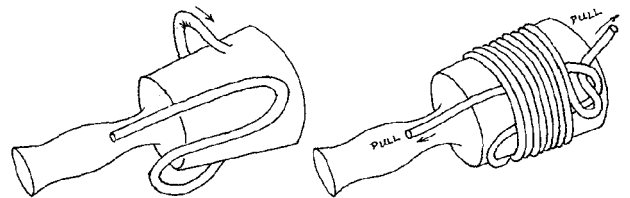

and apply two coats of well-thinned white glue afterward. The glue soaks into the string and prevents it from fraying and unraveling.

—Riff Masteroff, Arlington, Va.

Restoring old tools

To restore old tools the process I generally follow is: Use Murphy oil soap with very little water to wash off excess dirt and grit, and let it dry thoroughly; sand with 6/0 wet-dry sandpaper or 4/0 steel wool; treat the wood with two coats of Minwax antique oil, which does a better job than linseed oil;

METHODS (continued)

apply paste wax and buff; soak all metal parts in a rust remover and then buff them on a wire wheel; coat the blades with clear lacquer to keep them from rusting again.

—*R. K. Brunner, South Charleston, W. Va.*

[Editor's note: While lacquer will protect metal parts, it will clog the stone when sharpening tools that are to be used.]

Polishing turnings

During the past fifteen years I have had considerable experience with lathe turning. I have found that after all the cutting has been completed and the turning is sanded to 220-grit and steel-wooled with 4/0, the wood is polished to a low lustre that still shows any small pits or striations remaining from sanding. Since these areas will not polish, they should again be sanded and steel-wooled. Polishing the turning with its own shavings will result in a satin lustre which can be left as is, or then lacquered, oiled, etc.

—*Paul L McClure, Denver, Colo.*

Waxing saw tables

On all machine platens, such as saw tables and jointers, bottoms of planes and such: Use a good car wax such as Simonize, and you will be surprised how much better they perform. Wood will slide and not stick; rust will not form in wet weather. I use it on all of my chisels and any tool that comes in contact with the wood.

—*Ellis Thaxton, Arlington, Tex.*

Raising arched panels

The shaper is the correct tool for making a raised panel door with an arched top. I don't have a shaper, so I do the job with the table saw and a chisel, the hard way.

Make the rails and stiles, with tenons and mortises, in the usual way and cut the panel to shape. Set up the table saw to cut the bevel, with the blade angled to the correct slope, the height set for the width of the bevel, and the fence placed to the edge thickness of the panel. The straight sides are no problem, just run them through. On the arched top, run the piece through resting on the top of the arch, then again

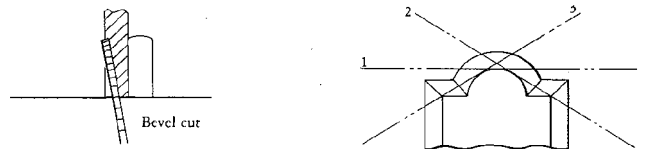

resting on the top and one corner, and again resting on the top and the other corner.

Now set the table saw to cut the shallow shoulders on the bevels, thus removing the waste from the work. This com-

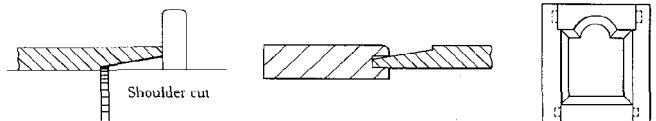

pletes the straight sides, except for cleanup with a rabbet plane, and removes most of the wood from the arched top.

Mark the shoulder line on the arched top and the 45° lines at the changes of direction. Use a wide, sharp chisel to carve the bevel down, making a neat, sharp juncture at the 45° line. Marking the correct thickness on the panel edge and carving back to the shoulder line is one way to do it.

The grooves that accept the panel in the straight sides are easily made with a dado blade in the table saw. To make the groove in the top rail, drill holes somewhat smaller than the desired thickness of the groove, then chisel out the groove to the line. Don't worry about the sloppy bottom of the groove, just make the sides nice and even.

Assemble the door dry, pin through the tenons with dowels, and fit it to its opening. Then take it apart and re-assemble without the panel to round over the inside edge of the frame with a router. The panel should be finished before glue-up to prevent an unfinished edge from showing through as the door expands and contracts over the years. Make sure the panel is slightly loose on final assembly; that's the whole idea, allowing a little room for expansion and contraction.

—Gary Hall, Hampton, Ga.

Dovetail square

I do a considerable amount of hand-dovetailing and find an adjustable bevel or protractor a bit awkward. Since pin and tail angles remain constant (I use 12°), I have made a square at that angle that is very easy to use. Mine is made from well-cured cherry with 3/16-in. birch pins. The body is a laminate of two 1/4-in. thick cheek pieces, 6 in. long, and two 1/8-in. center pieces, 3 in. long, cut at 12° on the inner ends. The blade is 1/8 in. thick and 6 in. long.

I assembled my tool dry in clamps to drill the pin holes,

METHODS (continued)

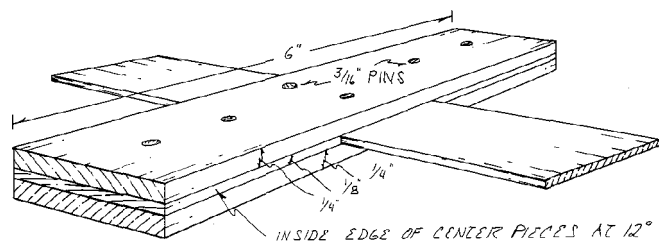

then I removed the blade and pinned the body together dry. After trimming the ends smooth, I lapped all the working edges, including the blade, with 220-grit paper placed on a surface plate.

Reassemble with glue and clamp, and you have a handy tool that never has to be set or checked, and can easily be flopped to pick up the other angle.

—Don Kenyon, Naples, N. Y.

Finishing clocks

I build hall and wall clocks. I use only walnut lumber. When I am finished with the case I don't fill the wood or stain it. I use only hot boiled linseed oil, nothing else. It makes a very beautiful finish. The grain seems to come to the surface in streaks of brown and some black. If there is a knot it turns black. For heating the oil I use an electric glue-pot of one quart size. I heat the oil to a point where it is too hot to put on with a rag, so I use a 1-in, nylon paintbrush. A brush also gets into the corners better than a rag. After the oil is

METHODS (continued)

applied, let it set until you see dry spots appear. This could take from 5 to 20 minutes, depending on room temperature and humidity. Then take a wool cloth or pad and rub the wood until the oil seems to disappear. What you are doing is forcing the oil into the wood. One or more coats can be applied. If one of my clocks is scratched or nicked, all it takes is a little sanding and a little hot oil and the scratch disappears.

—George Eckhart, Kenosha, Wis.

More clamps

Here is a simple hand clamp that can be made without any threading or tapping—the only tools needed are a drill and a chisel. The idea is taken from old wooden handscrews that were given to me a few years back. There are no reverse threads and the jaws open and close parallel to each other. I hold the center handle in my left hand and spin the clamp around it clockwise to close the jaws; this keeps the jaws parallel until they are the desired distance apart. A turn or so on the rear handle then supplies enough pressure for any glue joint.

The threaded parts are 3/8-in. threaded rod sold at the hardware store. Get nuts to match and simply mortise them

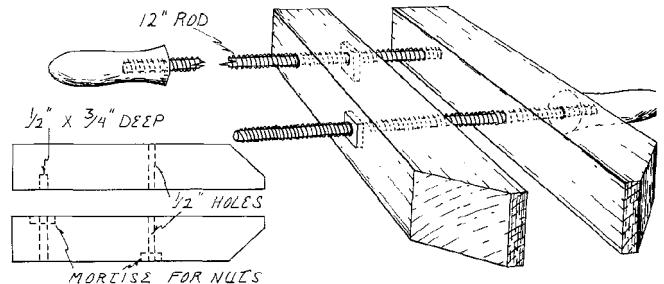

into the hardwood jaws. If the mortises are loose, you can use epoxy glue to hold the nuts in place, just a dab, and keep it away from the threads. The holes are drilled 1/2 in. to allow easy passage of the rod. The turned handles are held firmly on the rod with epoxy glue pushed into a slightly oversize and overdeep hole.

—Albert C. Landry, Richmond, Maine

Trimming veneers

Matching veneer pieces on a long edge requires a truly straight cutting procedure. Bookmatching is particularly fussy, for any departure from a straight line is doubled when the pieces are positioned. The traditional solution is to clamp the veneers between cauls and hand-plane the exposed edges. It doesn't work very well—the cauls do not distribute pressure properly to the veneers (usually puckered), and planing a three-foot length to a few thousandths of an inch is rarely a happy adventure.

By using a form of pattern routing, employing a piece of ground tool steel as the pattern, the precision cutting of veneer edges becomes routine. The ground stock is available at any tool and die supply house. Although it is expensive, (about \$25 for the size shown) do not stint on size; accuracy is based on the stiffness of the steel cross section. To avoid distortion, do not heat-treat the bar or machine it in any way. Simply embed and bond to the upper jig section. I used

METHODS (continued)

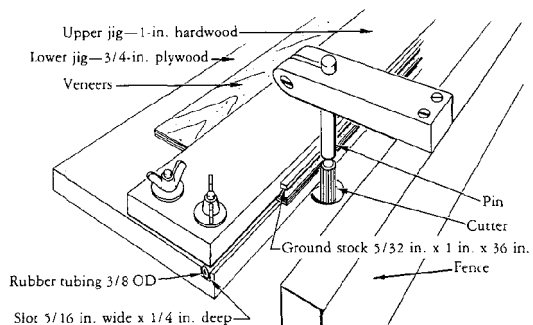

polyester resin, instead of epoxy, to make the ultimate retrieval of the steel simplifier. Polyester resin develops about one-third the strength of epoxy on metal.

To clamp the wavy veneers, I use a rubber tube that is simply pushed into a snug groove in the lower board. I suspect that foam weather-stripping would work as well.

The upper jig member should be made of a hardwood (mine is cherry) but the wider lower member can be made of plywood. If after clamping a full load of four veneers there is some visible bow in either piece of the jig, do not be alarmed. The only necessity is support along every inch of the veneer edge. Unsupported veneer will chip off.

To use the jig, first set your router into a shaper table. Use a straight carbide cutter. Attach a metal pin, equal in diameter to that of the cutter, to the fence so that the pin is centered on the cutter and about 1/2 in. above it. Great precision is not required; eyeballing the pin location is adequate. With the pin guiding the steel bar, the cutter will generate a nearly

perfect edge on the veneers in one pass. Even such hard and brittle materials as Brazilian rosewood are easily cut.

—Leon Bennett, Riverdale, N. Y.

Poor boy's scriber

Perhaps my poor boy's scriber might suggest a useful project. The point is a nipped-off 6d nail in a hole drilled

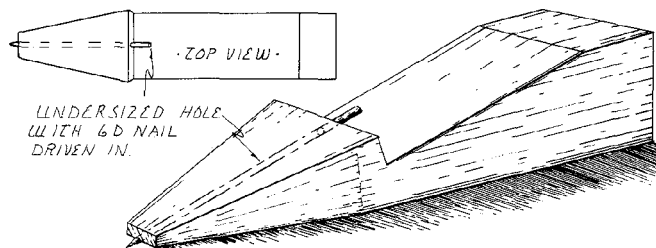

undersize for a drive fit. This gadget eliminates error that a round-pointed tool might make because of the angle at which it is held.

—Earl Solomon, Orchard Park, N. Y.

When screws snap

When a screw snaps off in hard wood and there is no way to get it out, I take a 2-in. length of steel gas line. Make some saw teeth on one end and put it in a drill. When the screw is out, fill the hole with some 5/16-in. dowel.

—Edwin A. Chard, jr., Rochester, Ill.

Routing slots

Slots for the splines in miter joints can be cut neatly and quickly with a router and a straight bit (carbide-tipped works best). With the depth of cut set to one-half the width of the spline plus $1/32$ in. for excess glue, rest the base of the router on the face of the miter. Adjust the router fence (a block clamped to the router base will probably work better) so the

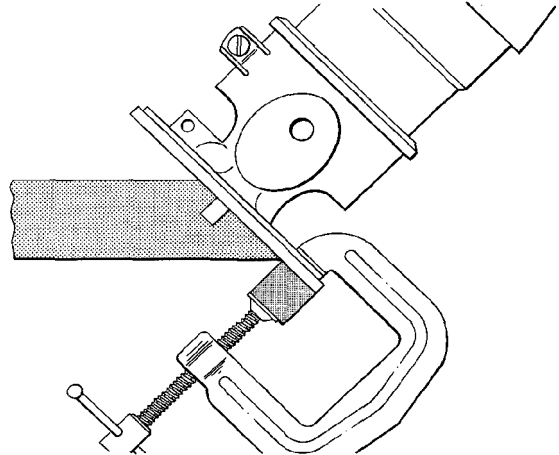

outside edge of the miter will guide the bit as it cuts the slot. Using as a pivot the point where the outside miter edge meets the corner formed by the router base and the fence, lower the bit into the face of the miter and cut the slot. This method cuts the slot parallel to the edge of the miter, which helps the spline compensate for cup in the board, and the cut can be started and stopped without exposing the spline at either end of the joint.

—David Landen, Chapel Hill, N. C.

Mortising plane

Here is a very old design for a plane to cut the mortises when inlaying hardware. It works like a router plane, but is more flexible as it can reach places the router cannot go, such as when inlaying hinges in door jambs. Because the two side pieces are raised from the sole, the corners of the blade can cut right up to shoulders and moldings. I have found the 14-in. plane most useful because it gives a sure surface for any hardware up to 7 in. long. Of course for a special job the plane can be made longer or shorter.

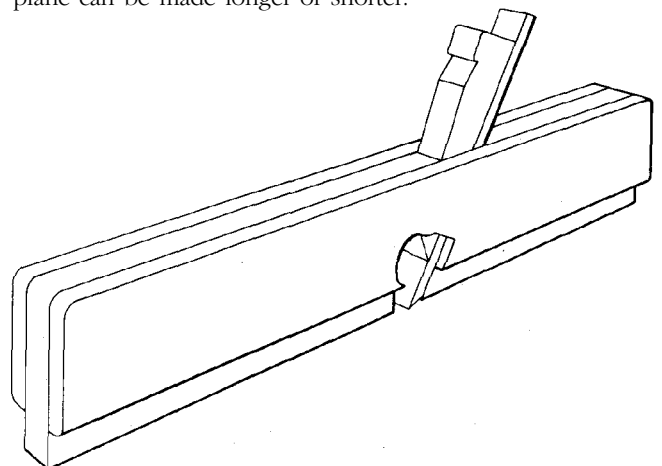

METHODS (continued)

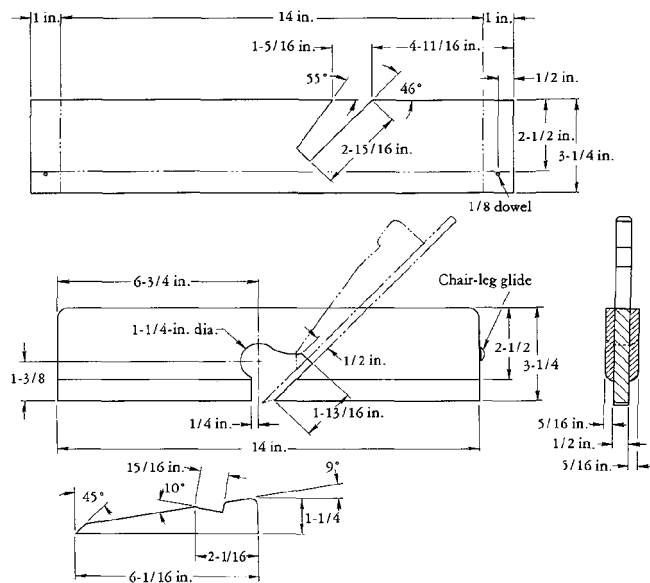

You need one piece 5/8 in. x 3-1/2 in. x 16 in. of maple or some other dense wood; two pieces 3/8 in. x 3 in. x 16 in. that may be in a contrasting wood if you like; one piece 5/8 in. x 1-1/2 in. x 6-1/2 in. for the wedge; and one piece of steel 1/4 in. x 1/2 in. x 9 in. Oil-hardening steel, which comes in 18-in. lengths, is well-suited and that is why the iron is 9 in. long. After the steel is cut and ground, send it out to be hardened or do it yourself (*Fine Woodworking*, Fall '76).

First make the centerpiece, which is notched and finished to 1/2 in. thick. Drill two 1/8-in. holes as shown in the drawing and insert two dowels, to locate the side pieces during glue-up. Plane the side pieces to 5/16 in. thick and clamp the assembly together, using cauls for straightness because the sides are so thin. Be sure to clean out the glue where the wedge and iron will fit, and clean it off the bottoms of the side pieces. When the glue has set, cut the plane to length, locate and drill the 1-1/4-in. hole and complete the cut-out shape. Round the edges of the upper part of the cut-out, so the shavings will slide off easily.

Now make the iron and fit the iron. Move the iron back a quarter inch from the bottom and tap the wedge home, and then correct the sole for straightness. If you true the plane without the iron and wedge in place, it may change when they are pressing against the wood. To lower the iron, tap it at the top. To move it up, tap on the back of the plane. To protect the wood, you might want to hammer in a chair glide, or inset a hardwood striking button. If you wish to remove the iron completely, tap against the notch in the wedge.

—Tage Frid, Foster, R. I.

Threads in end grain

When tapping wooden threads with a homemade or commercial steel tap (*Fine Woodworking*, Spring '77), good clean threads can be gotten only when tapping perpendicular to the grain of the wood. It sometimes is necessary in the design of a certain project to tap directly into end grain, as in a turning, in which case the threads will be torn out. However, the tap can be sharpened so that the wood fibers on the inside surface of the pilot hole are cut before the root of the thread, thus not tearing out the whole thread. The tap will also work just as

METHODS (continued)

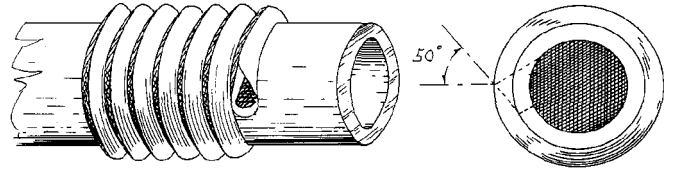

well when tapping perpendicular to the grain.

Looking at the end view of the tap, it is filed so that the angle of the two cutting edges is sloped back from the radial position. This could be anywhere from 40° to 50°. A 45° file can be used to rough-form the inside bevel of the cutter. The edge can then be finished with a small slip stone.

—William Stockhausen, Northville, Mich.

Orbital sander

I use three orbital sanders in my shop. They have a lengthy "coasting" time and it is time-consuming to hold a sander until it stops. I have found that a coasting (or running) orbital sander may be safely placed (with the sanding surface down) on a piece of shag carpeting set on the sanding bench.

—B. D. Bittinger, Shelbyville, Tenn.

Bending iron

I teach high-school woodworking and for the past two years have had the students design projects that require bent wood. I have tried soaking and steaming with limited results, so I designed and built a simple bending iron from an aluminum bar and an old steam iron. The wood is wet with a sponge only where it is to be bent. This eliminates the staining and raised grain caused by soaking or steaming, and it can be glued immediately if it is not wet too much. My students have used the iron to bend wood up to 1/8 in. thick for projects ranging from guitar and dulcimer sides to fishing nets.

Start with a 6-in. length of round aluminum bar, and hacksaw it in half lengthwise. Sand the cut surface smooth on an aluminum oxide belt, and file all the edges smooth. Pick two steam holes in the sole of the iron, drill them out and thread them to accept #10-32 machine screws. Drilling elsewhere on the sole risks breaking into the heating element. Thread only as deep as the original steam holes, else the tap may bottom out and break off. Now locate these holes on the bottom of the aluminum block, drill through with a 1/4-in.-diameter bit for clearance, and countersink the top of the holes for the flathead screws. The screwheads may need to be

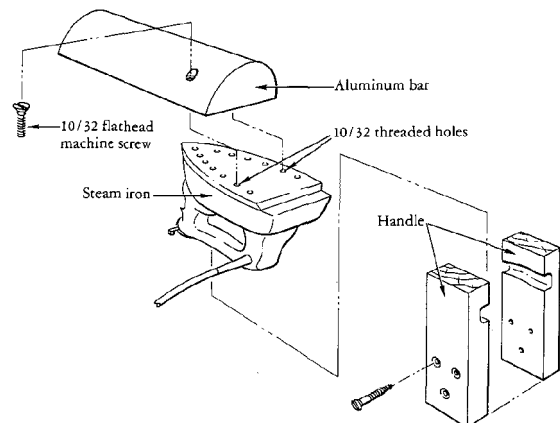

METHODS (continued)

filed flush after assembly. I started with 1-1/2-in. screws and ground them to length so they would tighten in the threaded holes without bottoming. Finally, groove two chunks of 2x4 to fit around the handle of the iron, so it may be clamped upright in the vise.

—David G. Johnson, Hanover, N. H.

Dip for screws

When you purchase a box of wood screws (brass or steel), dip them in a solution made of two tablespoons of bowling-alley wax dissolved in a pint of mineral spirits. Spread the screws out on a piece of kraft paper to dry before returning them to the box for storage. It will keep the brass bright, the steel from rusting and will make them go into the wood with half the effort, thus reducing breakage.

—Charles F. Riordan, Dansville, N. Y.

Repairing cracks

In the process of repairing furniture or using seasoned lumber we occasionally encounter a split board. Depending on the severity of the crack and the value of the lumber, it is sometimes desirable to repair the crack. A vacuum cleaner, masking tape, clamps and glue can accomplish this. Tape over the crack, down the end of the board and on the underside of the crack. The object is to create a vacuum.

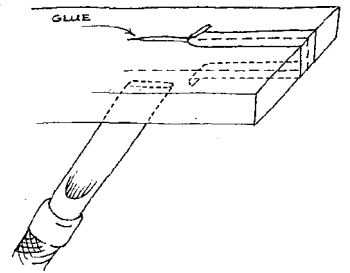

With a crevice tool on the vacuum cleaner, suck the glue into the crack while slowly peeling back the masking tape. Add glue while sliding the crevice tool out to the end of the board. Once the crack is filled with glue, clamp the split closed. The viscosity of glue is usually sufficient to prevent it from being sucked into the vacuum-cleaner hose. To be safe, remove the hose as soon as glue is visible on the underside. A little experimentation will show you how much time, glue and tape to use.

—Ray Schwenn, Jamesville, N. Y.

Fluting columns

On the clock I am building now are four fluted half-round columns, each 1 in. high and 1-3/4 in. wide, two of them 41 in. long and two of them 16 in. long. Each has five flutes. To make these columns I took pieces of walnut 1-1/16 in. x 1-3/4 in. and marked the ends to the half-round I wanted. I

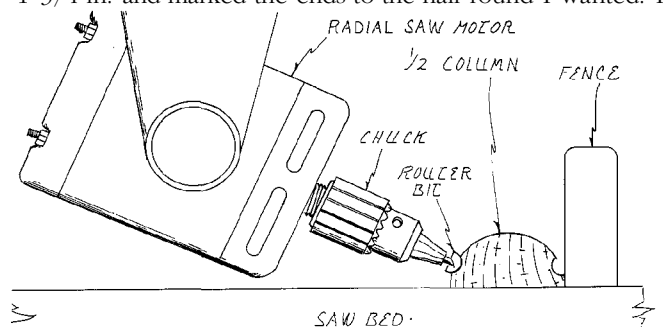

METHODS (continued)

then took off some of the waste on the jointer and the rest with a hand plane. To get them perfectly half-round I took a 6-in. length of tubing with an inside diameter of 1-3/4 in. and cut it in half lengthwise. Inside of this I put a piece of 60-grit sandpaper to shape the wood, followed by finer grits until it was smooth. To make the flutes I put a drill chuck with a router bit on my radial arm saw. I set the saw to the proper angle for the first flute, with the wood against the rip fence, and ran both edges of all four pieces through. I adjusted the saw setting for the succeeding flutes.

—George Eckhart, Kenosha, Wis.

A square square

To work accurately, the most basic necessity is a really accurate try square. While standing in the store you can't very well flop the square and scribe lines, but you can test one square against another, both inside and outside. Keep testing until you find two that will test inside and outside without any error—then buy either one since they are both square. While

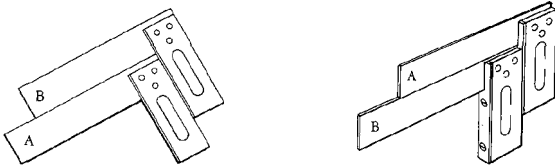

trying to find a square try square, I also discovered that a good many framing squares aren't really square either.

—Duane Waskow, Marion, Iowa

Routing slots

Slots for the splines in miter joints can be cut neatly and quickly with a router and a straight bit (carbide-tipped works best). With the depth of cut set to one-half the width of the spline plus $1/32$ in. for excess glue, rest the base of the router on the face of the miter. Adjust the router fence (a block clamped to the router base will probably work better) so the

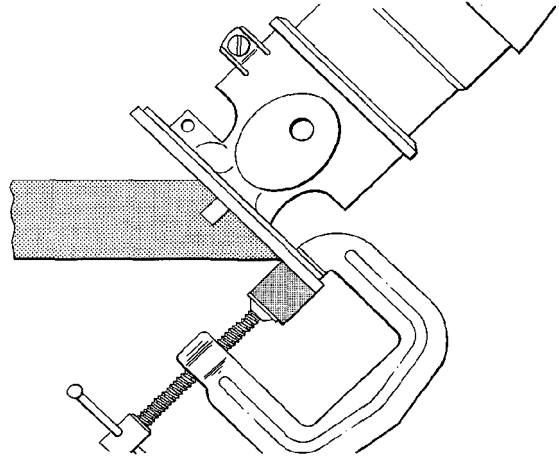

outside edge of the miter will guide the bit as it cuts the slot. Using as a pivot the point where the outside miter edge meets the corner formed by the router base and the fence, lower the bit into the face of the miter and cut the slot. This method cuts the slot parallel to the edge of the miter, which helps the spline compensate for cup in the board, and the cut can be started and stopped without exposing the spline at either end of the joint.

—David Landen, Chapel Hill, N. C.

Mortising plane

Here is a very old design for a plane to cut the mortises when inlaying hardware. It works like a router plane, but is more flexible as it can reach places the router cannot go, such as when inlaying hinges in door jambs. Because the two side pieces are raised from the sole, the corners of the blade can cut right up to shoulders and moldings. I have found the 14-in. plane most useful because it gives a sure surface for any hardware up to 7 in. long. Of course for a special job the plane can be made longer or shorter.

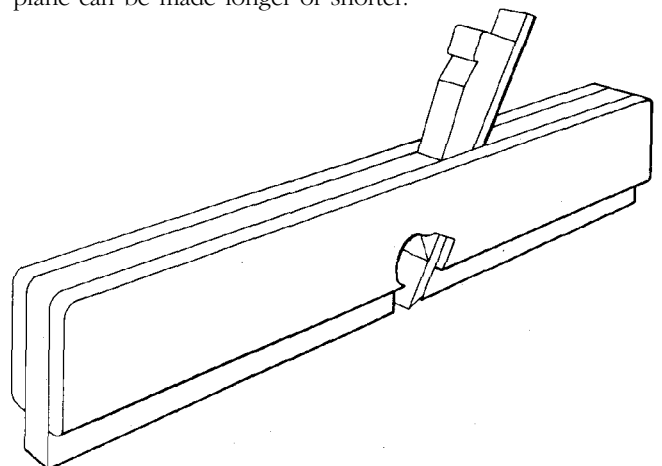

METHODS (continued)

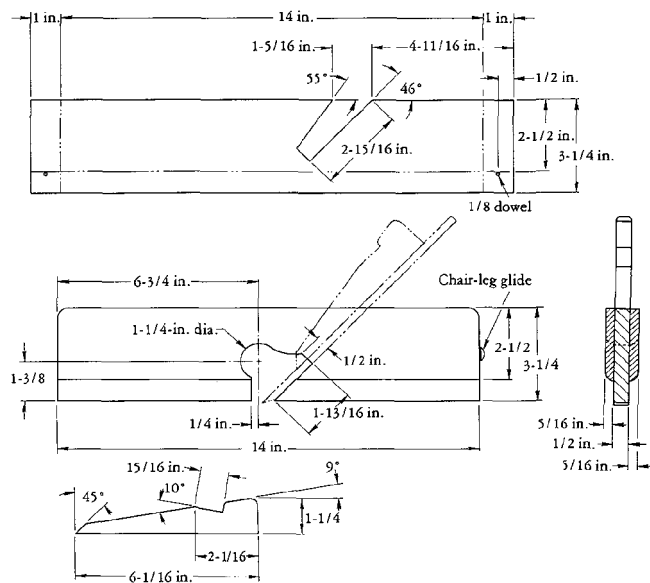

You need one piece 5/8 in. x 3-1/2 in. x 16 in. of maple or some other dense wood; two pieces 3/8 in. x 3 in. x 16 in. that may be in a contrasting wood if you like; one piece 5/8 in. x 1-1/2 in. x 6-1/2 in. for the wedge; and one piece of steel 1/4 in. x 1/2 in. x 9 in. Oil-hardening steel, which comes in 18-in. lengths, is well-suited and that is why the iron is 9 in. long. After the steel is cut and ground, send it out to be hardened or do it yourself (*Fine Woodworking*, Fall '76).

First make the centerpiece, which is notched and finished to 1/2 in. thick. Drill two 1/8-in. holes as shown in the drawing and insert two dowels, to locate the side pieces during glue-up. Plane the side pieces to 5/16 in. thick and clamp the assembly together, using cauls for straightness because the sides are so thin. Be sure to clean out the glue where the wedge and iron will fit, and clean it off the bottoms of the side pieces. When the glue has set, cut the plane to length, locate and drill the 1-1/4-in. hole and complete the cut-out shape. Round the edges of the upper part of the cut-out, so the shavings will slide off easily.

Now make the iron and fit the iron. Move the iron back a quarter inch from the bottom and tap the wedge home, and then correct the sole for straightness. If you true the plane without the iron and wedge in place, it may change when they are pressing against the wood. To lower the iron, tap it at the top. To move it up, tap on the back of the plane. To protect the wood, you might want to hammer in a chair glide, or inset a hardwood striking button. If you wish to remove the iron completely, tap against the notch in the wedge.

—Tage Frid, Foster, R. I.

Threads in end grain

When tapping wooden threads with a homemade or commercial steel tap (*Fine Woodworking*, Spring '77), good clean threads can be gotten only when tapping perpendicular to the grain of the wood. It sometimes is necessary in the design of a certain project to tap directly into end grain, as in a turning, in which case the threads will be torn out. However, the tap can be sharpened so that the wood fibers on the inside surface of the pilot hole are cut before the root of the thread, thus not tearing out the whole thread. The tap will also work just as

METHODS (continued)

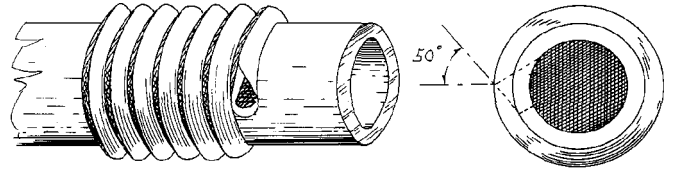

well when tapping perpendicular to the grain.

Looking at the end view of the tap, it is filed so that the angle of the two cutting edges is sloped back from the radial position. This could be anywhere from 40° to 50°. A 45° file can be used to rough-form the inside bevel of the cutter. The edge can then be finished with a small slip stone.

—William Stockhausen, Northville, Mich.

Orbital sander

I use three orbital sanders in my shop. They have a lengthy "coasting" time and it is time-consuming to hold a sander until it stops. I have found that a coasting (or running) orbital sander may be safely placed (with the sanding surface down) on a piece of shag carpeting set on the sanding bench.

—B. D. Bittinger, Shelbyville, Tenn.

Bending iron

I teach high-school woodworking and for the past two years have had the students design projects that require bent wood. I have tried soaking and steaming with limited results, so I designed and built a simple bending iron from an aluminum bar and an old steam iron. The wood is wet with a sponge only where it is to be bent. This eliminates the staining and raised grain caused by soaking or steaming, and it can be glued immediately if it is not wet too much. My students have used the iron to bend wood up to 1/8 in. thick for projects ranging from guitar and dulcimer sides to fishing nets.

Start with a 6-in. length of round aluminum bar, and hacksaw it in half lengthwise. Sand the cut surface smooth on an aluminum oxide belt, and file all the edges smooth. Pick two steam holes in the sole of the iron, drill them out and thread them to accept #10-32 machine screws. Drilling elsewhere on the sole risks breaking into the heating element. Thread only as deep as the original steam holes, else the tap may bottom out and break off. Now locate these holes on the bottom of the aluminum block, drill through with a 1/4-in.-diameter bit for clearance, and countersink the top of the holes for the flathead screws. The screwheads may need to be

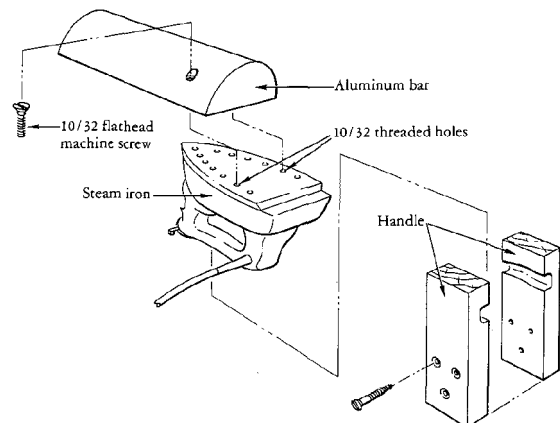

METHODS (continued)

filed flush after assembly. I started with 1-1/2-in. screws and ground them to length so they would tighten in the threaded holes without bottoming. Finally, groove two chunks of 2x4 to fit around the handle of the iron, so it may be clamped upright in the vise.

—David G. Johnson, Hanover, N. H.

Dip for screws

When you purchase a box of wood screws (brass or steel), dip them in a solution made of two tablespoons of bowling-alley wax dissolved in a pint of mineral spirits. Spread the screws out on a piece of kraft paper to dry before returning them to the box for storage. It will keep the brass bright, the steel from rusting and will make them go into the wood with half the effort, thus reducing breakage.

—Charles F. Riordan, Dansville, N. Y.

Repairing cracks

In the process of repairing furniture or using seasoned lumber we occasionally encounter a split board. Depending on the severity of the crack and the value of the lumber, it is sometimes desirable to repair the crack. A vacuum cleaner, masking tape, clamps and glue can accomplish this. Tape over the crack, down the end of the board and on the underside of the crack. The object is to create a vacuum.

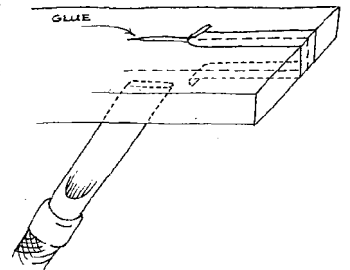

With a crevice tool on the vacuum cleaner, suck the glue into the crack while slowly peeling back the masking tape. Add glue while sliding the crevice tool out to the end of the board. Once the crack is filled with glue, clamp the split closed. The viscosity of glue is usually sufficient to prevent it from being sucked into the vacuum-cleaner hose. To be safe, remove the hose as soon as glue is visible on the underside. A little experimentation will show you how much time, glue and tape to use.

—Ray Schwenn, Jamesville, N. Y.

Fluting columns

On the clock I am building now are four fluted half-round columns, each 1 in. high and 1-3/4 in. wide, two of them 41 in. long and two of them 16 in. long. Each has five flutes. To make these columns I took pieces of walnut 1-1/16 in. x 1-3/4 in. and marked the ends to the half-round I wanted. I

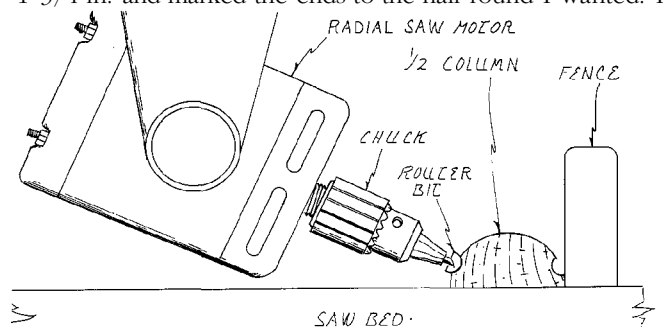

METHODS (continued)

then took off some of the waste on the jointer and the rest with a hand plane. To get them perfectly half-round I took a 6-in. length of tubing with an inside diameter of 1-3/4 in. and cut it in half lengthwise. Inside of this I put a piece of 60-grit sandpaper to shape the wood, followed by finer grits until it was smooth. To make the flutes I put a drill chuck with a router bit on my radial arm saw. I set the saw to the proper angle for the first flute, with the wood against the rip fence, and ran both edges of all four pieces through. I adjusted the saw setting for the succeeding flutes.

—George Eckhart, Kenosha, Wis.

A square square

To work accurately, the most basic necessity is a really accurate try square. While standing in the store you can't very well flop the square and scribe lines, but you can test one square against another, both inside and outside. Keep testing until you find two that will test inside and outside without any error—then buy either one since they are both square. While

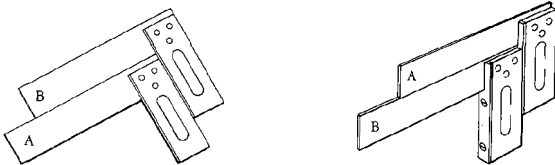

trying to find a square try square, I also discovered that a good many framing squares aren't really square either.

—Duane Waskow, Marion, Iowa

Pipe steamer

A simple and cheap steamer for bending wood (*Fine Woodworking*, Fall '77) can be made using a pressure cooker and some ordinary pipe fittings. Screw out the center post of

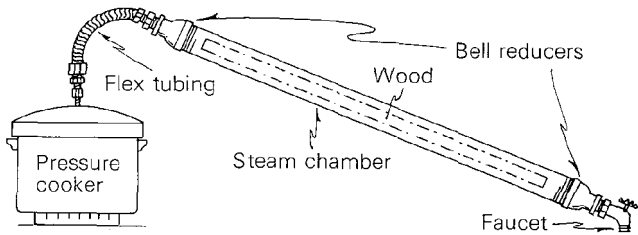

a pressure cooker. A Presto brand cooker has $\frac{1}{4}$ -in. pipe threads; others may be different. Purchase adapters for this fitting so it will connect with $\frac{1}{2}$ -in. flexible (ribbed) tubing, and a pipe nipple and bell adapter to bring the other end out to fit a 2-in. pipe. A piece of 2-in. pipe about 50 in. long makes an excellent steam chamber. The length should be an inch more than the longest piece you plan to bend; you can always lengthen the chamber by adding couplings and more pipe. Use another bell reducer on the other end, then put on a faucet to regulate the amount of steam and drain excess water. I use our kitchen pressure cooker; all these fittings cost less than \$15.

Cut and shape the wood the way you want it to be finished,

then put it in the chamber and screw on the bell reducer and faucet assembly. Fill the pressure cooker to about 2 in. from the top, tighten all fittings, screw into the top of the cooker, and open the faucet. After it starts to steam, close this valve so the water drips out but just a small amount of steam escapes. Never close the valve all the way, or an explosion could occur. A piece of straight-grained wood $\frac{3}{8}$ in. thick should easily bend around a form for a Windsor chair after thirty minutes of steaming.

If you use a pressure canner that has a gauge on it, you can safely steam wood with pressurized steam. For safest operation, remove the gauge and attach your steam tube to that hole, leaving the rocker assembly in place. Fit the gauge on at the end of the steam chamber by using a pipe tee and reducing bushings. Using the end valve as a regulator and keeping an eye on the gauge, you can generate superhot steam up to 240° F (at 15 lb. pressure). Ten pounds will cut the steaming time approximately in half. Watch the gauge at all times and be sure that the pressure cooker's safety valve is clean. Always let some steam escape through the end valve to keep the superheated steam flowing around the wood.

—George Pilling, Elgin, Ariz.

Repairing with glue

To re-attach edge splinters on lumber or to reglue a glue void beneath the face veneer of plywood, spread the splinter open or lift the veneer up with a sewing needle, razor blade or palette knife. Then lay a fine glue bead next to the crack or

METHODS (continued)



void. Force the glue into the void by blowing through a short length of flexible tubing that is narrow in diameter—windshield-washer hose or fine surgical tubing, for example. Then remove the spreaders and clamp.

—Steve Voorheis, Missoula, Mont.

Banding plywood

Plywood can be easily and neatly edge-banded using a 90° flute shaper cutter (Rockwell #09-106) and cutoffs from solid

stock. Adjust the shaper to cut a notch centered in the edge of the plywood and deep enough to cut into, but not through, the edge of the veneer on each face. If the cut is too deep, the cutter tends to fuzz up the end grain of the veneer or else chip it loose. For the band, rip triangular strips from solid stock of about the same thickness as the plywood. These strips can usually be made from scraps from the rip saw if you choose pieces with two surfaces jointed at a right angle. Unless the bands are cut from the edge of a board, it is probably safer and easier to rip these narrow triangles on a band saw. Glue the strips into the notches, and trim the excess on a table saw, jointer or by hand plane. The jointer or table saw will need some son of spacer, a piece of 1/4-in. plywood, for example to prevent the corner of the band from causing an uneven cut.

If more than two parallel edges of the plywood are to be banded, all of the edges can be notched at the same time and

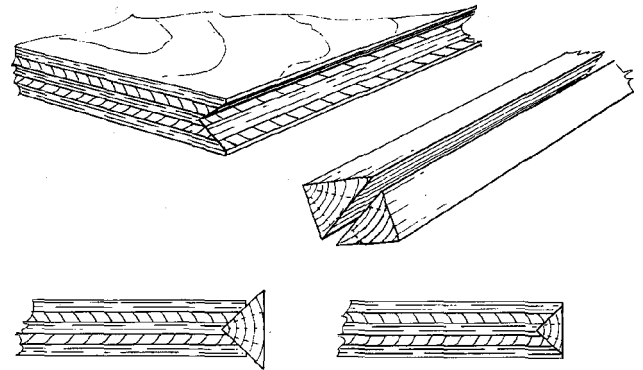

METHODS (continued)

the bands mitered at the corners, or two parallel edges can be notched, banded and trimmed before the notches are cut into the other edges. The second procedure leaves two small triangles of end grain exposed on two edges of the plywood.

If the band is trimmed carefully, which is not too difficult to do, it is not visible on the face of the plywood, and the picture-frame look that usually accompanies edge bands is avoided. Because the notch provides a large surface area for gluing, the band is exceptionally strong. The solid wood edge makes hinges mounted on plywood doors more secure, for example, and even provides a reasonably strong glue surface for plywood-to-plywood butt joints and the like.

—David Landen, Chapel Hill, N.C.

Better V-block

I made a flageolet as Kent Forrester describes (Fall '77, p. 80) and ran into difficulties in laying out and drilling the holes and in holding the flageolet down while working on it. Although I used a V-block, the slightest jiggle caused misalignments that became painfully evident after all the holes were bored. By adding two clamps atop the block and using a fence for the drill-press table, I was able to drill the holes in successive flageolets precisely and predictably. Mounted in a workbench vise, my modified V-block held the flageolets securely while I worked the windways, channels and slots. To make this V-block, you need less than 2 ft. of construction-

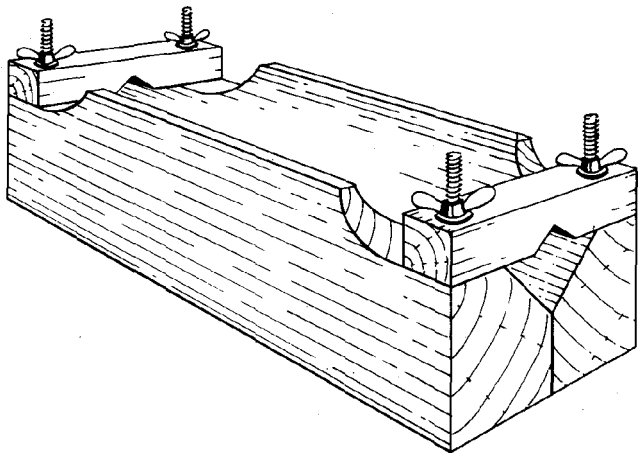

grade 2x4, 6 in. of 1x1 and four hanger bolts with wing nuts and washers. The two 45° bevels that make up the 90° "V" are planed on the jointer and then carefully aligned before gluing. The clamps and the coves at the end of the body are bandsawn; a spindle or drum sander does a nice job of cleaning up the curves. Most of the dimensions are not critical.

—Bernard Maas, Edinboro, Pa.

Trimming veneers

There is an easier and cheaper way to trim long edges of veneer than Leon Bennett's pattern routing jig (Summer '77, p. 16). Make a guide from 3/4-in. stock as long as the veneer, joint the edge straight and band with Formica. Put a lever-acting hold-down on each end of the guide board. Then set the veneer on the board, put a shorter piece of 3/4-in. stock on top and tighten the hold-downs, as shown. Set the shaper or

METHODS (continued)

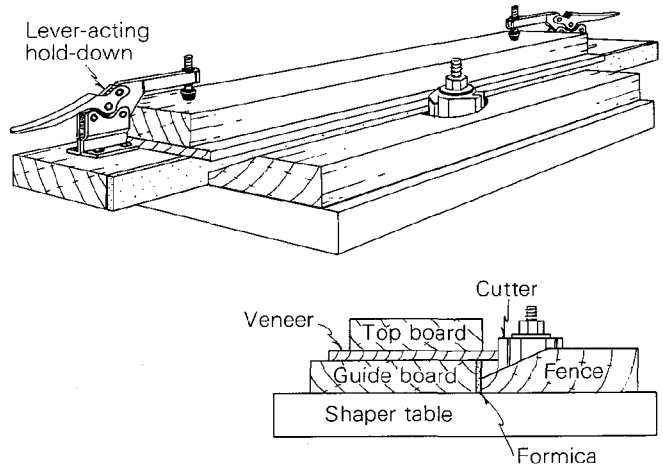

router cutter back $\frac{1}{16}$ in. from the edge of the fence so that the cutter won't nick the edges of the guide boards as it trims the veneer. Trim with the grain of the veneer to prevent chipping, and be careful to hold onto the board. With this method I've joined veneers for 4-ft. x 10-ft. conference table tops with no problems.

—Jim Sieburg, Chicago, Ill.

Marquetry patching

Your marquetry picture is cut, mounted, sanded and with a coat of finish, but something seems wrong. This happens often, because no matter how carefully you select veneer, you don't notice until the end that a piece doesn't look right. Some people just cut out the section to be replaced, trace the opening and insert a new piece. With my method, the section is traced before cutting.

With tracing paper taped to the picture, draw the section you wish to replace. Tape the tracing paper with carbon paper and trace the pattern onto the new piece of veneer. Then cut out the piece. Lay it on top of the picture to see how it looks; if you don't like it, cut another piece.

With the new section positioned on the picture, secure half of it with tape and score around the other half with a knife, using the veneer as a guide. Then tape the scored side, remove the tape and cut very carefully along the marking through the veneer that is to be replaced. With a small chisel or square-bladed X-acto knife, stab this veneer in the center and pry it up, working carefully from the center to the edges. Now fit the new section into the gap. If it doesn't fit, sand or shave the edges until it does. Glue with white glue and press. Then wipe off the excess glue and sand just a little with fine sandpaper backed by a wooded block to get dust into the cracks that are filled with wet glue. Put a small board and a heavy weight atop the piece and let it dry overnight. Then sand until all is level, and finish.

—Peter L. Rose, Saddle Brook, N.J.

Storing clamps

Instead of piling all your clamps into a tub, as if the contents were to be thrown out with the trash (Fall '77, p. 64), you can easily make a rack to store them. Lay your wood clamps on a piece of $\frac{3}{4}$ -in. plywood and determine the place-

METHODS (continued)

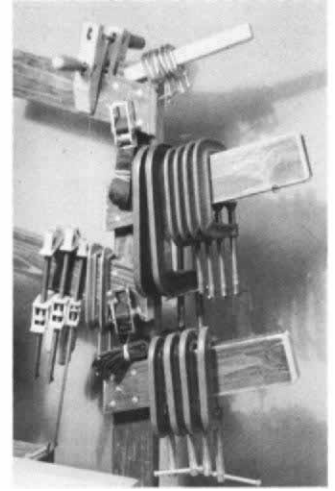
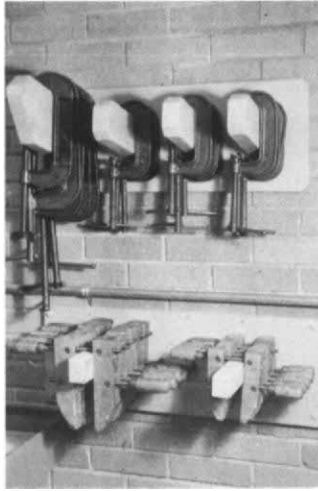

ment of the hangers by marking the space between adjusting screws and jaws. Hangers are made from 2x4 stock cut to a loose fit between adjusting screws and glued into snug holes in the plywood at 90° to the base. You can make a rack for C-clamps in the same way, but set in the hanger parts at 80° rather than 90°; for large C-clamps, use 2x6 stock. A free-standing clamp "tree" can be made from 2x4 stock.

—Everett Traylor, Bettendorf, Iowa

Glass scraper

Microscope slides work very well as scrapers, particularly in tight places like the interiors of small boxes, or drawers. When the edge is fresh, they cut beautifully, and though they lose the edge faster than a metal scraper, they are disposable and don't require the time spent on resharpener. I've found that so-called petrographic slides (27mm x 46mm) are sturdier than biological slides (25mm x 75mm). One supplier (of many) is Buehler, Ltd., 2120 Greenwood St., Evanston, Ill., 60204. The order number is 40-8000-001 for 1 gross, price \$7.00.

—John Reid, Amherst, Mass.

Repairing trim

A piece of furniture may seem beyond repair if a large chunk of ornate trim is missing or damaged. The repairman may lack the skills to carve a new piece of wood, or the carving may cost more than the furniture itself. The answer is to make a mold from the existing trim and cast a new piece with auto body putty, better known as bondo.

Bondo comes in two parts, a resin and a catalyst. It does not dry, but rather cures, and therefore (unlike plastic wood) does not shrink. When it has cured it can be shaped and drilled like wood. It won't absorb stain, but can be painted or colored with Blendal powdered stains (from Mohawk Chemical Co., Amsterdam, N.Y.) to match the surrounding wood.

To make a mold, remove a section of undamaged trim from the furniture and drive a couple of finishing nails into the back of it, to act as handles. Fill a container with plaster of Paris, grease the front surface of the trim with any light oil, and push it firmly into the plaster. As you set the trim, wiggle it a bit to ensure a good contact and be careful not to let the plaster flow over the back of it. When the mold has hardened, use the nails to pull the trim out. The finish on it will

METHODS (continued)

be blushed from the moisture in the plaster, but it can be restored by using Mohawk's blender flow-out, which comes both glossy and flat.

New trim can now be made by greasing the mold and pouring bondo into it. Stir gently to get rid of air bubbles. When the bondo starts to cure, set a few nails in the back for handles so it can be pulled from the mold. After it is solid it can be pared with a knife, sanded and cut to fill the damaged area on the furniture. Attach it with epoxy glue. Bondo continues to cure for about a week and if you wait too long to trim and sand it, it will be like steel.

Bondo can also be used to repair a damaged corner or other area where it isn't practical to make a mold from existing trim. First clean the damaged area and cut away any slivers of wood. Don't be afraid to enlarge it—another half-inch won't make any difference. Drive a few finishing nails into the damaged area to anchor the bondo, but make sure the heads are below the undamaged surface. Now wrap aluminum foil around some small pieces of wood, such as tongue depressors, and tape them to the undamaged wood so they bridge the repair zone and act as a form for the bondo. Trowel in the plastic, in layers if necessary, and when it cures remove the forms. You'll have a crude representation of the undamaged area, which can then be shaped with a knife and sandpaper.

—Glenn Rathke, Pompano Beach, Fla.

Triangle tips

An architect's 45° triangle is inexpensive and handy around the shop. Attach a ½-in. x ½-in. strip of walnut along the hypotenuse with No. 2 R. H. brass wood screws to make a miter square. Take care not to cut into the edge of the triangle when you scribe with a metal instrument.

—Dwight G. Garrett, Centerville, Kans.

An inexpensive but accurate plastic drafting triangle gives a perfect 45° setting on the table saw. A long wood face on the fence with sandpaper attached prevents slippage and further

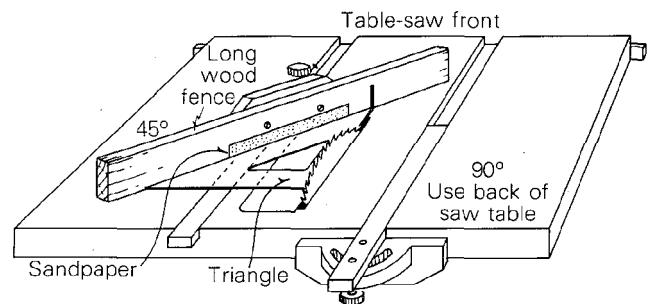

improves accuracy. For a perfect 90° setting on the saw gauge, turn it over, push it against the back of the saw table, and tighten.

—Jim Richey, Houston, Tex.

Knife profile patterns

Because shaper knives and hand planes cut at an angle (*Fine Woodworking*, Winter '76, p. 61), a molding profile cannot be directly traced onto a blank and ground to shape.

METHODS (continued)

This method will help you make a blade that will reproduce a desired molding pattern. First, determine the angle a of the knife as it cuts the wood. Then

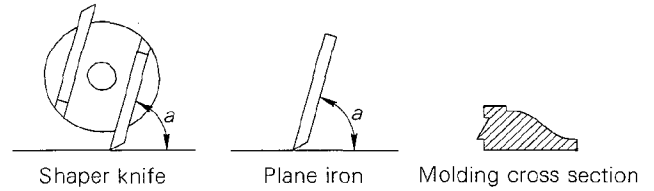

draw a cross section of the molding shape. To this sketch add the outline of the knife as it cuts the wood. Then draw a folding line and a side view of the knife at angle a and at its true length. Now add another folding line parallel to the knife length, and beyond it draw a knife blank. Ex-

extend construction lines from several points on the molding profile, through the first folding line at 90° , to the edge of the knife length. It is possible to construct a template the actual shape and size of the knife you want to make by measur-

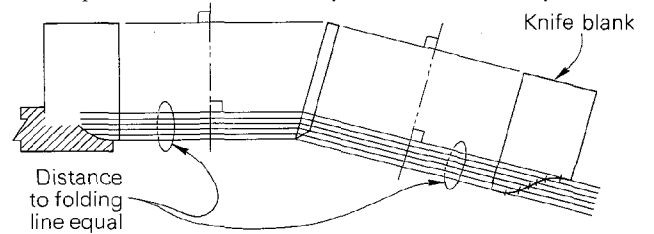

ing with dividers from the first folding line back to the construction line intersection points on the molding outline, then transferring these measurements from the second folding line to the knife blank. All construction lines must pass through the folding lines at 90° .

—Ron Davidson, Port Angeles, Wash.

Gluing frame

I found I did not have a really flat gluing surface and had to improvise one. I used an old window frame to set up my pipe clamps for gluing up solid wood panels. The trick is to keep the clamps parallel and in the same plane, to make sure the panels have no glued-in twist or wind. After notching the frame to accept about half the diameter of the two pipes, place winding sticks across them fore and aft and sight across the top of the sticks to spot any variation from parallel. If there is a variation, simply deepen the one notch necessary to bring the pipes into line.

Once you have tried this setup, don't move it, because the surface on which it is next placed may vary and change the

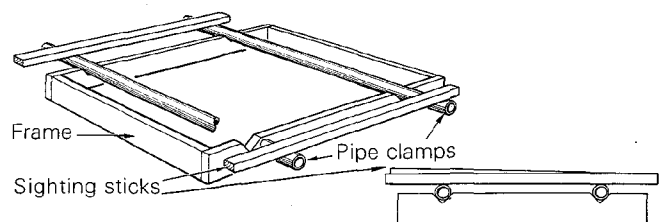

METHODS (continued)

parallelism. When gluing the boards together, place the good side down and use one or two clamps across the top of the boards to even out the pressure. Always use scrap strips between the clamp jaws and the wood to distribute pressure and avoid marks.

—Duane Waskow, Marion, Iowa

And more clamps

Perhaps some readers might be interested in making some adjustable clamps entirely of wood, as I have done. The dimensions can be varied to suit one's needs.

These clamps don't operate quite like the metal-threaded ones since both screws are right-handed. However, I have found them to be quite satisfactory. In use one tightens the

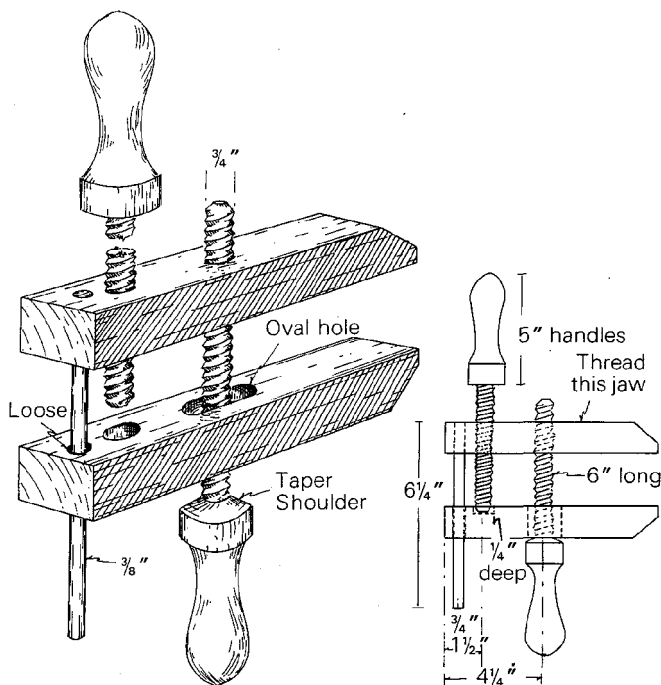

inner screw to clamp the work, then secures the jaws by spreading the outer screw. The small dowel serves as a guide rod to keep the loose jaw in alignment. The hole in the loose jaw should be oval to permit angular pieces to be clamped. Of course, hard maple or other dense wood should be used.

—Arvle E. Marshall, Watkinsville, Ga.

Sizing

When cutting threads in end grain, an aid to preventing tear-out (Fall '77, p. 19) that will give clean-running threads is to "size" the wood. After drilling the hole in the end grain (or any surface, for that matter) coat the hole with a watery glue (polyvinyl acetate, plastic resin, etc.) thin enough to penetrate the fibers. Less tear-out will occur during the tapping. Afterwards apply more coats of sizing to harden the wood further.

Sizing so applied increases the toughness of any running or bearing surface.

Another use of sizing is to raise the grain. Before the final sanding, apply a thin wash coat of sizing. Avoid thermoplastic adhesives (the white and yellow glues) because they

METHODS (continued)

soften with friction and load up abrasive paper. Brown glue such as Borden's or Weldwood plastic resin sand and harden the wood especially well. Another way to raise the grain is with thin shellac or lacquer. When it dries, the sizing "keeps" the wood fibers and grain raised, so they can be sanded away. If a better surface is not immediately noticed, the improvement may well be apparent after several months of humidity fluctuation.

—C. B. Oliver, Durham, N.H.

Truing a drill-press table

A drill-press table can be leveled easily and accurately with a piece of coat-hanger wire bent into a "Z." Fit one end into the drill chuck, and adjust the height until the other end of the wire just scrapes against the table. Now rotate the wire 180°. If the table is exactly 90° to the drill chuck, then the wire will still scrape the table slightly after being rotated. If it doesn't, adjust the table until it does. The surface is true when the wire scrapes it to the same degree in every position.

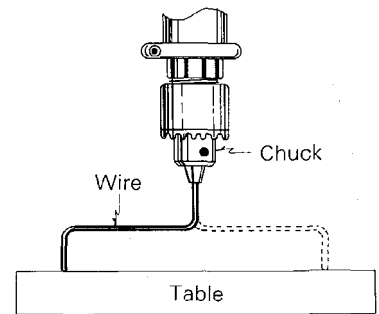

—Lyle Terrell, New Orleans, La.

METHODS OF WORK

Leg Vise

For years I have admired in museums and photographs those sturdy, simple contraptions I call leg vises. They are mounted at one end of a bench, in front of and parallel to its front leg, and are as high as the top of the bench. This type of vise was prevalent in old woodshops both in this country and abroad. A day at a bench equipped with one and you begin to understand its previous popularity and question its present scarcity.

This vise can be adjusted to hold at various angles and gains much of its holding power from simple leverage. It is capable of holding much larger pieces of wood, both in width and thickness, than most commercial bench vises can. Because the bottom of the front jaw is on the floor and the rear jaw is the bench itself, it is quite stable (or as stable as your bench) and will withstand great abuse from pounding. With the addition of a few holes and a peg or two in the other front leg, you can support long boards on edge. Hardware can be had from \$15 to \$20 from well-stocked tool suppliers such as Woodcraft Supply Corp., 313 Montvale Ave., Woburn, Mass. 01801. But for less than half that price you can have a leg vise with features that standard bench screws don't allow.

You will need a piece of wood about $3\frac{1}{2}$ in. by $3\frac{1}{2}$ in. by the height of your bench, a pipe-clamp or bar-clamp fixture, a piece of pine 1 in. by 4 in. by 12 in., a dowel, a couple of wood screws and a few hand tools. For wood I've used common $\frac{4}{4}$ fir, but anything you have will work. Softwoods can be fitted with hardwood faces at the inside top for better wear. The lower adjustment shown in the diagram works the same as the second screw on a handscrew works. It enables you to keep the vise faces parallel, or at the angles you need. The hole in the upper part of the vise must be elliptical to allow for changes in the relationship of the pipe to the jaw. These changes take place only vertically, so the width of the ellipse should match the outside diameter of the pipe, usually $\frac{3}{4}$ in. I bore two holes at 75° off horizontal, intersecting at the center of the wood. This gives a round hole in the center of the piece and ellipses at the outer edges. Cutting two parallel holes also works but is sloppy.

With this bar-clamp system, you get quick action by releas-

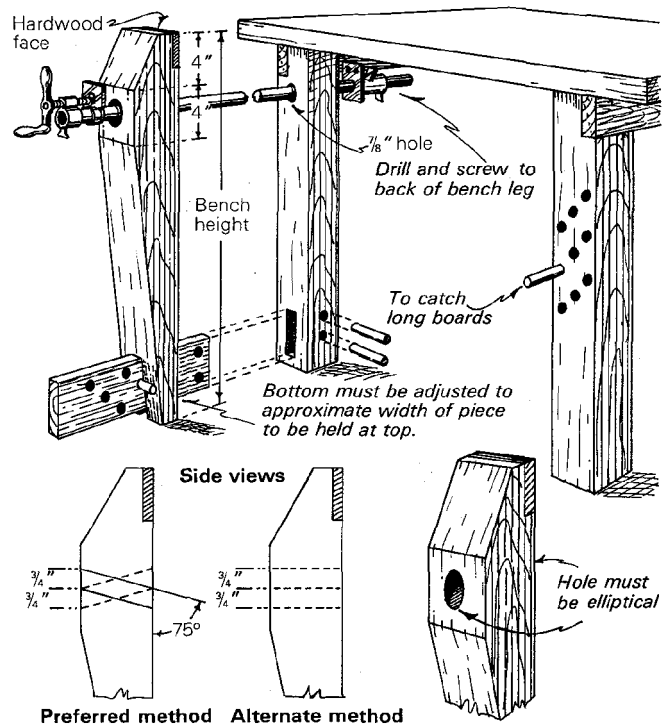

METHODS (continued)

ing the bar at the stationary fixture behind the bench leg. Simply pushing closes the vise on whatever is in it. A quick short twist of the crank and all is secure.

—Craig Schoppe, Arlington, Vt.

Fixing new saws

As a general rule, new crosscut hand saws are not sharpened properly. The trouble appears to be the result of forming and sharpening the teeth by machine, after which the teeth are set. As these saws are sold, they feel sharp enough but they don't cut as well as they should and they tend to wander. One can tell about this by looking along the teeth. They should look like *A*, but they almost always look like *B*.

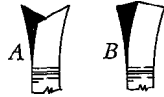

Sharpening a new saw to correct this is easy. It is well worth the trouble. Any set of accepted directions will do, just ignore those for leveling the teeth and resetting them. Neither is necessary. The only trick is to make sure the teeth are at equal depth. Even, the saw cuts straight with no problem. Uneven, it wanders and cannot be held true. Count the file strokes for each tooth and don't try to make each tooth perfect the first time. Give each, say, five firm but not heavy strokes. Then, when all teeth are done, check the saw. If one needs more, they'll all need it. Carry on with the same number of strokes per tooth, maybe two or three if you're close, until they're all alike.

You don't need a saw vise or some other special tool. You do need a thinner file than you think. A couple of pieces of heavy wood or plywood on both sides of the blade, the edges just below the teeth, and the whole put in any vise, will do, and you'll never again have to say you can't saw a straight line. Amazing how much time you can save using a hand saw, especially if you have a good setup table to use for the purpose instead of your fancy cabinetmaker's bench, one with an overhanging top so you can clamp a piece along the side of the table if you need to.

—Henry T. Kramer, Somerville, N.J.

Repairing knots

As a weekend woodworker I find I cannot afford top-quality walnut, nor can I afford to waste any of the waddle walnut I buy. Many times a fine piece of well-figured waddle walnut will have a badly checked knot. I file the check out until I have about $\frac{1}{8}$ -in. vertical surface all the way around. Then I plane a scrap of similar grain and color to $\frac{1}{8}$ -in. thickness and tape it over the opening so that the grain closely matches the solid stock. I turn the entire unit over and spray a latex paint through from the back to give me the exact shape of the check, then I cut, file and sand the "plug" to a perfect fit. After gluing and filling in from the back for support, and sanding, it will be hard to spot this easy repair job.

—Dan Quackenbush, Olathe, Kan.

Making chisels

One source of steel for making special tools is the local junkyard. High-carbon steel can be found in auto leaf springs, spring-tooth harrows, bed rails and many other things. You can determine the type of steel, or at least its relative hardness, by trial and error with a file or a hacksaw: If you can cut it or mark it with relative ease, then it is not what you want.

I needed several mortising chisels, and old bed rails lent themselves to this type of tool. Bed rails are usually $\frac{1}{8}$ in. thick and $1\frac{1}{2}$ in. across the right-angle flats. The rails can be cut with a hacksaw, but you will use a lot of blades. They are easy to cut if you first remove the temper by heating with a propane torch wherever you wish to cut.

First I laid out the design for the tang and sides of the

METHODS (continued)

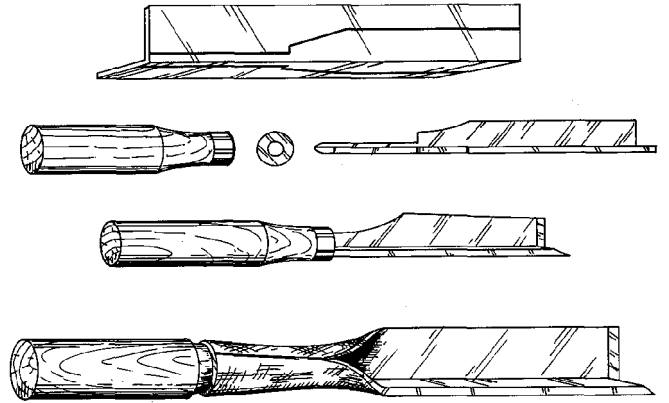

blade, then I roughly cut out the blank with a hacksaw. I finished shaping the tool with a bastard and second-cut file, leaving the cutting edge until after the handle was driven onto the tang. The handle can be bought or turned on a lathe, or shaped by hand. To keep the wood from splitting, I used ½-in. thin-walled electrical conduit for the ferrules, and a common washer on the shoulders of the tang. I predrilled the hole and drove the handle onto the tang. Then I filed the cutting edge to shape and tempered it.

My method of tempering the cutting edge is adapted from a technique I learned from an old blacksmith. First heat the metal to cherry red, place the tip in cold water for a few seconds, then file across the beveled cutting edge until a straw color appears. Then immediately and completely immerse the metal in cold water. You will have to use trial and error to get the right hardness. The propane torch is not hot enough to temper a complete cross section of bed rail.

When a furnace or an acetylene torch is available, you can make larger tools such as socket chisels and mortising chisels from bed rails and auto leaf springs. I use a tapered pin in a machinist's vise as a form for the socket. By hammering and reheating it is possible to form the socket around the pin. Then I turn handles of hickory wood to fit the socket. First drive the handle into the socket, then shape the cutting edge on a grinder and with files. Finish by tempering and polishing.

—Lester E. Rishel, *Beliefonte, Pa.*

Clamping with bedsprings

Old bedsprings make excellent—and cheap—clamps for hard-to-clamp jobs, such as clamping veneer on curved surfaces. They can also be used for small solid wood patches. Springs can be cut to different sizes, then bent to put pressure in the exact spot needed. A piece of Saran wrap and a block of wood placed over the veneer will give more even clamping pressure, without marring the work. A caution: Bedspring clamps can suddenly spring off, if wrongly placed.

—Robert S. Friedensen, *Winston-Salem, N. C.*

Flattening cupped boards

It is difficult to flatten a cupped board with a thickness planer ("Q&A," Winter '77 and Spring '78) because the downward pressure of the feed rolls will press out much of the cup, thereby not allowing the planer knives to flatten the board. As it emerges from the planer, it simply springs back to its original cup. To counter the pressure of the feed rolls, I tape wooden strips to the concave side of the board. My method is designed for a planer with a single cutter positioned above the board as it passes through the machine.

First run the board through the planer with its concave side up to obtain an even surface along the edges that will make

METHODS (continued)

the next step easier. Now set a straightedge across the board, as shown, to determine the correct thickness for the wooden strips. It is usually easier to use several short strips than one long one, especially if the board is very long or irregularly cupped. With reinforced (cloth-backed) tape, fasten the strips to the board in the area of greatest depth of curvature. Wide masking tape will also work. Now run the board through the planer with the convex side up. The wood strips underneath will prevent the downward pressure of the feed rolls from flattening the cup. Thickness-plane until the con-

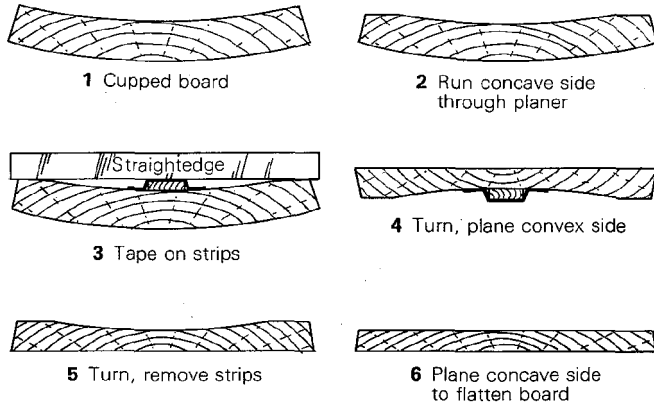

vex side is flat, then remove the tape and strips and run the board through again, concave side up, until the concave side is also flat.

—Dwight G. Gorrell, Centerville, Kans.

Marking tips

Old furniture that is to be taken apart, repaired and re-assembled must be marked so that the pieces can be easily identified. Since surface marks will be obliterated by stripping and refinishing chemicals, it is best to use indentation marks. I mark all pieces before disassembly, and always on the underside. I mark only one end of the male/tenon member close to the female/mortise member. I use one set of chisel marks with the grain, then one set across the grain, then tiny nail-set marks. Next I use X marks or any combination of the above.

—Price G. Schulte, St. Louis, Mo.

Removing broken screws

I'm sure we have all broken off a screw head while twisting the screw into a tight hole. It is hard to remove the screw without damaging the piece. One remedy that I find works well utilizes two simple plug cutters. With one plug cutter, bore out a hole around the broken screw shank. If the screw is large and runs deep and cannot be snapped out with the plug, you can chisel away the plug and grab the shank with pliers. Be careful, however, not to damage the rim of the hole. Once the screw and plug are removed, you can fill the hole with a plug made with a cutter two sizes larger than the one used to cut the original hole. This method is better than using a dowel as a plug because the fit will usually be much tighter, the plug will be less visible since its grain will match that of the original piece, and the screw can be resunk across grain instead of into the end grain of a dowel.

—John Rocus, Ann Arbor, Mich.

Ball-bearing collars

My wood shaper has a $\frac{1}{2}$ -in. dia. spindle. In using spacer thrust collars for irregular edge molding, I found that the edge of the wood gets burned from the friction of the collars.

I purchased about a dozen $\frac{1}{2}$ -in. I.D. x $1\frac{1}{8}$ -in. O.D. sealed

METHODS (continued)

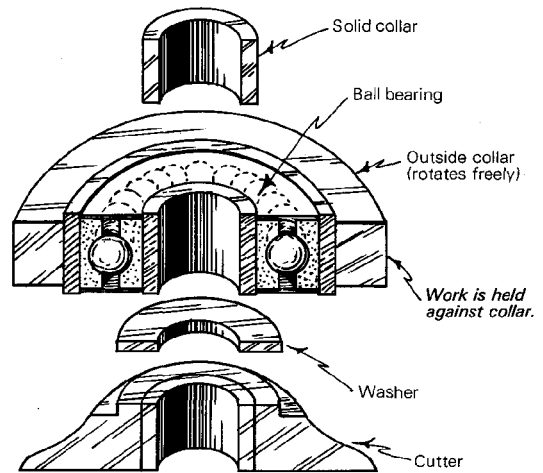

ball bearings, $\frac{3}{8}$ in. thick. Next, I machined collars to half a thousandth under the outside diameter of the bearings.

The O.D. of the collars were in steps of $\frac{1}{16}$ in., starting from $1\frac{1}{4}$ in. (the collars are thinner than the bearings). Next, I pressed a bearing into each collar, using the vise to keep the surfaces parallel.

It is important to use a solid collar that matches the inner ring of the ball bearing above and below the assembly, so that when the shaper nut is tightened the tension will be only on the inner ring—the outside will float. When the wood is pressed against the outside of the assembled collar, the outside perimeter stops rotating and only the spindle with its bearing rotates. I have used a small, thin washer on each side of the bearing, which permits the same freedom.

—George P. Calderwood, Long Beach, Calif.

Planing end grain

I used to cringe at the thought of sending end-grain slabs through a power planer. I do it often now and end up with cutting boards few people can bring themselves to cut on. Scrap pieces from the table saw are jointed smooth and glued together side to side along the length to form a laminate of different kinds of wood—the more species the better. (1) This laminated plank is planed down until smooth and then crosscut into strips on the table saw (2). The strips are stood up and then glued to each other. One can shift every

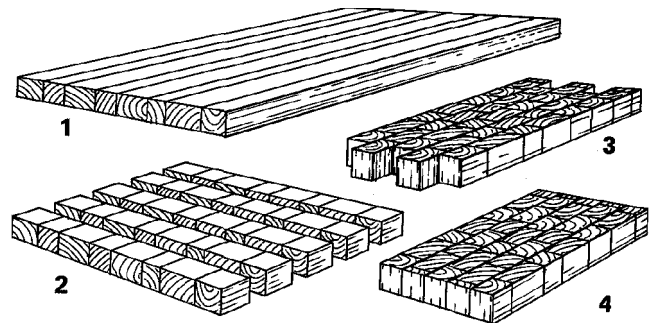

other strip a bit for a checkerboard effect (3) or line them all up straight. At least three bar clamps are used for each gluing step. Then run the slab through the planer until it is smooth (4). Then round the corners, bevel the edges, sand and finish with mineral oil. When the oil hits that end grain it will have been worth the effort.

Checkerboards may also be made in this way, using heavier stock. Only with experience have I been able to estimate the size of the finished board—it varies directly with how thick it is made. It helps to have a sharp planer but no matter how

sharp, some of the trailing edge is going to be chewed up. This is to be expected and must be compensated for, especially when making checkerboards.

—James B. Small, Jr., Newville, Pa.

Grinding knives

Nicked jointer or planer knives can be ground straight and true by making a rest that will hold them off the radial arm saw table. Then mount a stone in the saw and draw it back and forth over the knives. Another way is to mount a stone in the table saw and slide the knives back and forth against the miter gauge.

—John Owen, Isaacs Harbor, N.S.

Lag-screw tap

For occasional use, an ordinary 2-in. lag screw can be made into an effective wood tap in smaller sizes. Use a triangular



file to notch the bolt along about 1 in. Tilt the file to get more rake on the cutting edge. See "Wood Threads" (Spring '77, pp. 22-28) for making dies for wood.

—Jim Richey, Houston, Tex.

Mounting flute blanks

Those of us with limited equipment and money sometimes need merely to think a little harder than those with the equipment we lack. In "The Flageolet" (Fall '77, pp. 80-81), Kent Forrester advises mounting the drilled blank on the lathe with chuck-mounted abrasive cone centers to turn the flute to shape. Those without a chuck and abrasive cones can use this easy trick: Turn a 1-in. blank to the diameter of the bore, leaving about 1 in. at each end square. Cut this piece in

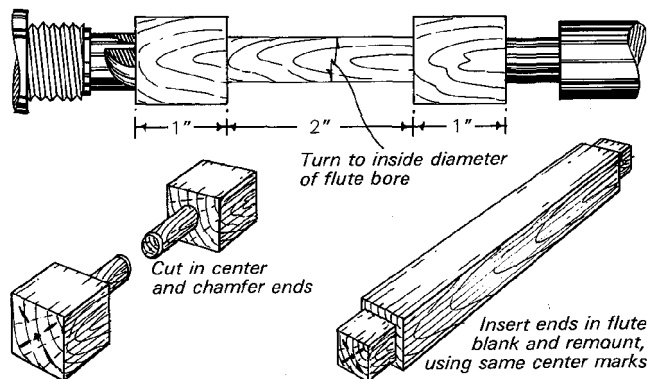

half, chamfer the round ends and insert them into the bore of the instrument. This assembly can be remounted on the lathe, using the same live/dead orientation and the same spur indentations. If the live end slips, I suppose masking tape would solve the problem, but I found I didn't need it.

—Bob Raiselis, New Haven, Conn.

Easier than pumice

Scotchbrite (an abrasive plastic wool) makes a good finishing material. It's easier to use than pumice and oil, and can be used dry so that you can see what you're doing. It's inexpensive and durable, but, being soft, is not as good as abrasive paper for taking off high spots. Scotchbrite is available in supermarkets or in various grades from welding supply houses.

—Edward S. Taylor, Lincoln, Mass.

METHODS OF WORK

Methods of Work is a forum for readers to exchange the tools, jigs and tricks they've devised. Send precise details, sketches (we'll redraw them) and negatives with photographs, if any. We pay at the rate of \$100 per magazine page, minimum \$20, upon publication.

Clamping boxes

Clamping and squaring large box pieces can be a problem. The pressure of the clamps often pulls the piece out of square at the critical moment of final tightening. The first hint is obvious but often forgotten: Get all the parts ready to glue and assemble, have all your clamps extended to the length you will need, and tape your softwood clamping blocks either to the work or to the clamp faces before applying any glue. Proper preparation saves precious time.

After assembling, tighten opposing clamps in small increments. When the pieces are just snug, measure the diagonals

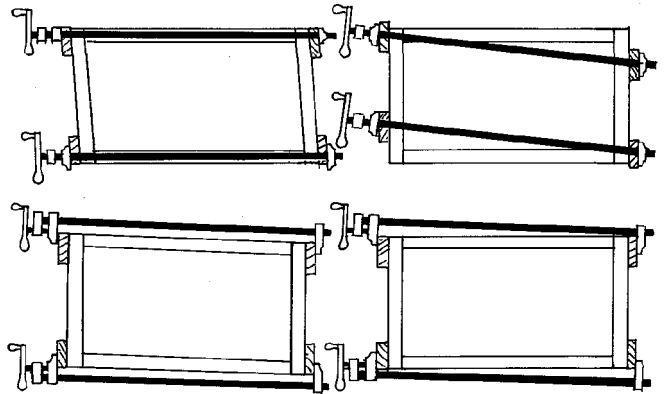

Out-of-square boxes, left, can be aligned by repositioning clamps to oppose the pull, as shown at right.

METHODS (continued)

for squareness. A folding rule with a slide extension is indispensable here. If the work is out of square, move the clamps slightly to oppose the pull, i.e., make the clamps pull more parallel to the longer diagonal. A very small movement will make a lot of difference.

This process becomes much more complicated if all four sides of the rectangle are open and being glued at once. But I have clamped together a post-and-rail crib with all four sides openwork and no top or bottom. Using eight clamps, I pulled it square in all directions at once. A final hint, which most know: Don't wipe the glue. It will be much easier to chip it off the surface than to sand it out of the pores later.

— George Pilling, Springville, Calif.

Ogee molding

Ogee molding is easy to make using the table saw with a jointer or hand plane. By setting up a diagonal fence on the table saw, the boards, usually 3 in. to 5 in. wide, are hollowed, leaving a flat section along each edge, one narrow and

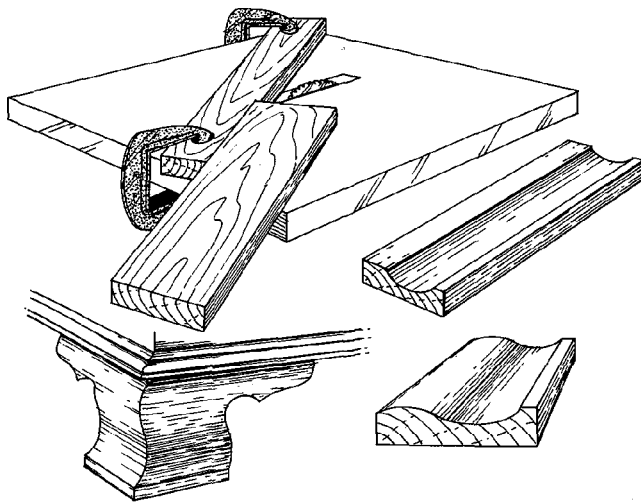

one wider. For 4-in. molding of the type usually used for bracket feet on case pieces, I usually leave a $\frac{3}{4}$ -in. flat along one edge, which will remain flat. Along the other edge is a wider plane, which I joint or hand-plane into the graceful curve that makes this molding so useful. For safety, always use a push-stick and make several passes over the table-saw blade, raising it perhaps $\frac{1}{8}$ in. at each pass. The fence is simply a board with a straight edge, clamped to the saw table at about 30° to the line of the blade. Other moldings, chair seats and even raised panels with beautiful curves forming the rise may be made using variations of this method.

—James B. Small, Jr., Newville, Pa.

Veneering cylinders

Paul Villiard in *A Manual of Veneering* makes two suggestions, among others, for veneering cylinders. (1) Use photographic print flattening solution to make the veneer flexible; and (2) clamp the veneer by wrapping the veneered cylinder in several layers of friction tape.

After veneering a large tapered cylinder, I offer these comments: (1) The print flattening solution produced very good results on a wavy and brittle zebrano veneer $\frac{1}{28}$ in. thick. (2) As an alternative to friction tape, I used strips of rubber bicycle inner tube. The strips are cut about $\frac{1}{2}$ in. to $\frac{3}{4}$ in. wide from an old tube. The strips should be cut as long as possible in a continuous cut around the tube. The strips are then stretched as tightly as possible around the veneered cylinder after gluing. I found I was able to get a much tighter

METHODS (continued)

wrap with one layer of rubber than with several layers of tape. And the rubber strips are reusable and virtually free if discard tubes are used.

—David J. Lutrick, Seattle, Wash.

Steam-bending jig

An inexpensive jig for steam-bending or bent laminations can be rigged up using an ordinary automobile bumper jack to supply the clamping force. First weld *U*-bolts to either end of a flexible steel strap of about the same length and width of the stock to be bent—I used a 36-in. by 1½-in. section of band-saw blade. Now attach a small pulley to the jack. With the jack installed in the jig framework so that its force is

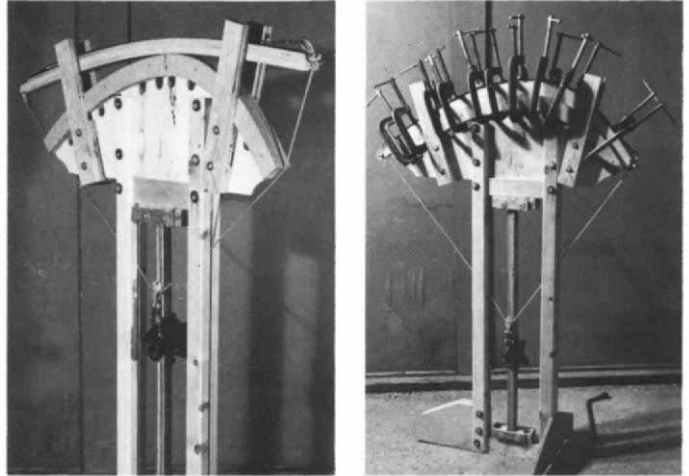

directed away from the bending form, thread wire rope through the pulley and jig framework, then attach it to the *U*-bolts with steel rope reinforcing loops and rope clamps.

Place the steamed or laminated material to be bent between the relaxed strap and the bending form head, then use the jack to pull it around the form. Clamping from the tightest point on the curve outward to each end will ensure perfect laminations. The form is secured to the jig with four bolts; other forms may easily be substituted.

—Steve Voorheis, Missoula, Mont.

Tapered turning head

When lathe-turning candlesticks or other items that have a center hole, the hole can be perfectly centered by drilling it first before turning is started, and then using a tapered turning head, such as the one shown. If the candlesticks are to be

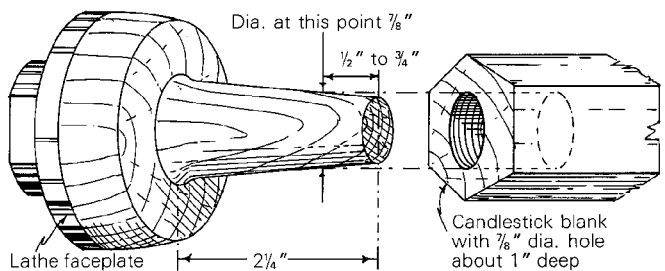

for standard 7/8-in. diameter candles, taper from a large diameter of about 1 1/8 in. down to a minor diameter of about 1 3/16 in. or slightly less. The important dimensions are 7/8-in. diameter at 1/2 in. to 3/4 in. from the small end, along with a smooth, straight taper.

The predrilled wood blank is slipped over the tapered head. Care must be taken not to overtighten, of course, as the taper will split the wood blank if too much force is applied. Making the overall length of the taper about 2 1/4 in. and using

METHODS (continued)

the diameters indicated seem to provide good tightness and good tool clearance for standard candlesticks.

Cutting away stock from the top of the turning adjacent to the tapered head shortens the workpiece and consequently loosens the grip of the head, so if you must cut at that point, be sure to remove only a small amount before stopping the lathe and retightening the tailstock. When finished, the work can be removed easily by backing off the tailstock and moving the work slightly from side to side until loosened. The result is a perfectly centered hole. This method has one other advantage: You proceed with turning *after* you know that you've drilled a good clean hole.

The same concept can be applied for other center-hole pieces as well by turning other tapers with different diameters. If you have several tapers, it's best to mount each one permanently on its own faceplate to ensure concentricity.

—L. L. Chapman, Newark, Ohio

Veneer strip thicknesser

For decorative inlay and border work, it is often an advantage to have all the strips of uniform thickness, or to alter the thickness for a special design. A simple scraper thicknesser assembled from scrap hardwood will do a quick and accurate job. A trued-up 2-in. square about 14 in. long forms the body of the jig, while two identical rotating arms (say 1 in. by 2 in. by 5 in.) support the scraper and adjust the cut and thickness by means of a common pivot bolt (say $\frac{3}{8}$ in.). The scraper is clamped to the arms with two small C-clamps.

To use the thicknesser, clamp one end of the body in the vise and loosely position the arms at an appropriate scraper angle. Clamp the scraper to the arms as shown, using shims on the body to determine thickness and to orient the edge parallel. Tighten the pivot nut and make fine adjustments by tapping with a hammer. Feed the strips under the scraper in

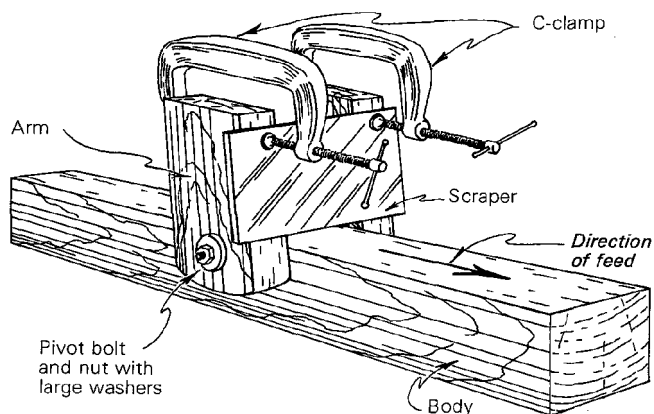

the direction shown and pull them through. Sometimes it helps to angle the strip to the blade. If the strips pull hard, rotate the arms and take a lighter cut. When sharpening the scraper, file straight across only about three-quarters of its length, then taper away at the end. This will permit starting the strips under the scraper near one arm, then sliding them over under the straight-cutting section for thicknessing.

—William D. Woods, Phoenix, Ariz.

Sanding small pieces

While doing some restoration work, I needed to inlay a patch in a veneered surface. The piece to be inlaid was a bit too thick. Ordinarily, one would sand it flush with the surface after gluing. In this case, sanding would have been impossible without marring the surrounding finish. I had to devise a way of holding the small piece so that it could be sanded evenly. I

METHODS (continued)

put coarse-grit sandpaper on the bench, then put the veneer patch on it. This way it could be easily and evenly worked with a sanding block, using a finer grit. When a thin workpiece is sandwiched between two grits, it locks into the coarser grit as pressure is applied and is held firmly.

—Joseph T. Ponessa, Moorestown, N.J.

Drawer "push"

I have seen several small boxes whose beautiful forms are interrupted by a knob. Indentations for the fingers to pull the drawer out may also work against the design of the box. My father taught me an alternative to these "pulls" and that is to push the drawer out. First drill a hole about two-thirds the depth of the thickness of the back of the box. If the rear wall is $\frac{3}{4}$ in. thick, I drill down $\frac{1}{2}$ in. Now drill a small hole the remaining distance through the wall of the box, then countersink the small hole on the inside of the box. Make a plug $\frac{1}{4}$ in. thick and fasten it from the inside with a screw that will move freely through the small hole. Pushing the plug in causes the screw-head to push the drawer out enough so that one can get hold of the drawer in front to pull it out the rest of the way.

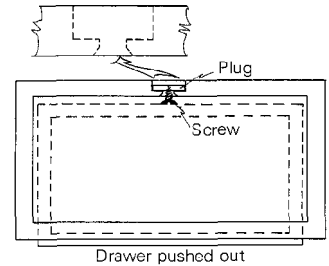

—John Roceanova, Bronx, N. Y.

Coating nails

Nails coated with rosin are difficult to pull out. To coat your own nails or brads, dissolve about 4 tablespoons of powdered rosin in about a half pint of denatured alcohol. Store in a tightly covered container. Pour a small amount of the solution into an old shallow pan or dish, then swirl the nails around in the solution until they are covered. Dump the nails onto old newspapers. Stir occasionally to separate the nails until they are almost dry, about five minutes. Then let them dry thoroughly.

—Price G. Schulte, St. Louis, Mo.

Sharpening setup

I have assembled a jackshaft on two sleeve pillow bearings. The shaft diameter is $\frac{5}{8}$ in., except for the extreme end, where it is reduced to $\frac{1}{2}$ in. and rests in a $\frac{1}{2}$ -in. pillow block bearing. To the inside position of the bearing the shaft is threaded for a $\frac{3}{8}$ -in. thrust nut, a stop collar at the opposite end of the shaft (inside the other bearing) and between the two are spacer sleeves and thrust or side plates for as many grinder or leather wheels as one wishes.

The shaft is driven by a $\frac{1}{3}$ -hp motor rotating backwards, or away from you, and has two step pulleys, one for grinding

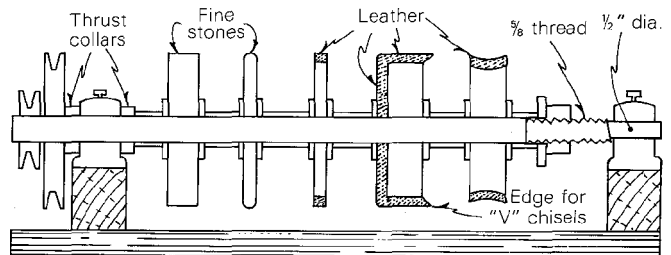

speed and the smaller pulley (driving) for honing my wood-carving or regular chisels. I made the discs of hardwood and covered their sides and periphery with leather.

—George P. Calderwood, Long Beach, Calif.

METHODS OF WORK

Methods of Work is a forum for readers to exchange the tools, jigs and tricks they've devised. Send precise details, sketches (we'll redraw them) and negatives with photographs, if any. We pay at the rate of \$100 per magazine page, minimum \$20, upon publication.

Tanksteamer

Letters in recent issues of *Fine Woodworking* suggest a need for a simple and safe wood steamer. I have made many chair rockers, back boards and splats, as well as wooden hoops, with the one described here.

It is a 12-in. by 60-in. hot-water tank with the top cut out. It has wrap-around insulation and a plywood lid with a soft rubber gasket. A 10-lb. weight holds down the lid. The tank sits on building tiles, and an electric hot plate is set between them. Presoaked wood is suspended above the water line on twine string. A caution: When removing wood, raise the lid slowly and away from you to avoid the hot steam. For longer wood, a downspout could be attached to the tank.

—Albert J. Gnaedinger, Pocahontas, Ill.

Removing mill marks

In order to achieve a good finish, the tiny ridges left by milling machines must be removed. The best method my students and I have found for removing mill marks is with the cabinet scraper (Stanley #80). The problem is being able to see these mill marks. By rubbing a piece of white chalk over the entire surface of a surfaced or jointed board, one can readily see these imperfections. The mill marks show up as white waves across the grain.

You can then scrape with a cabinet scraper until the chalk marks—and the mill marks—disappear. Drag the chalk across the stock again and it will hardly leave a mark. Using a cabinet scraper also reduces sanding time.

—Dennis W. Kempf, Bellevue, Wash.

Locking up tools

A miniature padlock attached to the plug of a portable tool or a free-standing machine prevents unauthorized use in the school shop. At home it is a safety measure that keeps small children from "helping." More than one plug can be locked

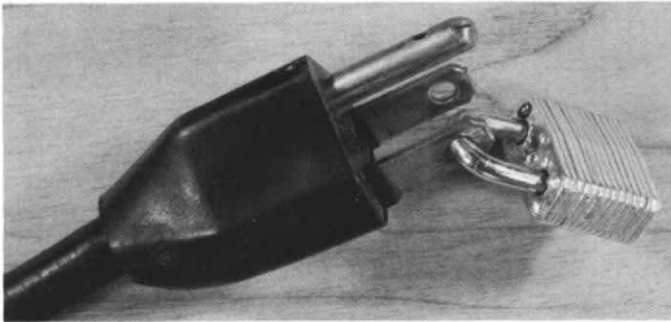

with a single padlock; the one shown here is Master Lock Co. No. 9B, available at hardware stores. Tools may also be locked to a fixed object, for security.

—R. Bruce Hoadley, Amherst, Mass.

Homemade cabinet scraper

Cabinet scrapers can be made to special shapes from old hand or power saw blades. Cheap saws seem to work as well as good ones. The ideal thickness is about $\frac{1}{32}$ in., and 3 in. by 5 in. is a nice size. After cutting out the scraper with tin snips—little nibbles will do a better job than big bites—hammer the edge to remove irregularities. With the scraper flat on an oilstone, rub to flatten the edges and continue the process begun with the hammer. Next, drawfile the edge in a vise, then back to

METHODS (continued)

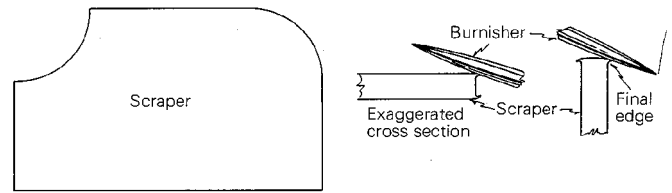

the stone, then draw the stone along the edge as you did the file. The object is to produce a sharp, square edge. Next, turn the edge with a piece of steel—a burnisher is best but a drill shank will work, as will an auto valve stem—anything hard and smooth. Hold the scraper horizontally, with the end of the edge you are working on braced against your chest. Then, pressing hard, draw the tool along the whole edge; reverse direction and do the other side. Then hold the scraper vertically away from your body and turn the edge down. The edge can be renewed several times by turning it down before you need to use the stone again.

—John Owen, Isaacs Harbor, N.S.

Gluing table

A most functional and sturdy gluing table is made of angle irons bolted to a wooden base. Dresser, tabletops and wide boards for beds are easily glued up using such a table. The construction allows easy application of clamps, and the spe-

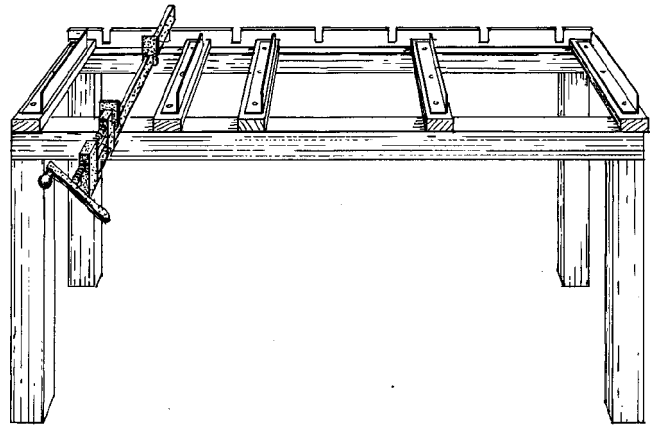

cially notched board at the back even holds bar clamps erect and up against the underside of the boards while you align and level them with one hand and crank the clamp with the other. If the vertical face of the angle iron is too narrow, it must be built up to make room for easy placement of clamps, since at least one will go on the underside of the board. Glue dribbles are easily cleaned off the irons with a few smacks of a hammer after they've dried.

—James B. Small, Jr., Newville, Pa.

Drilling angled holes

For my early American reproductions, such as cobbler's benches and step tables, I have found that splaying the legs about 5° in two directions is just about right.

I recently made a simple fixture for my drill press for boring the holes in the tops of these articles. I used two pieces of $\frac{3}{4}$ -in. plywood, 18 in. square; to both pieces I fastened a strip of wood to give me the desired 5° angle. This then works as a compound sine block. The plywood squares are hinged together; if you want the holes flared in only one direction, fold the top piece out of the way.

To determine the height of the elevating strip, I multiplied

METHODS (continued)

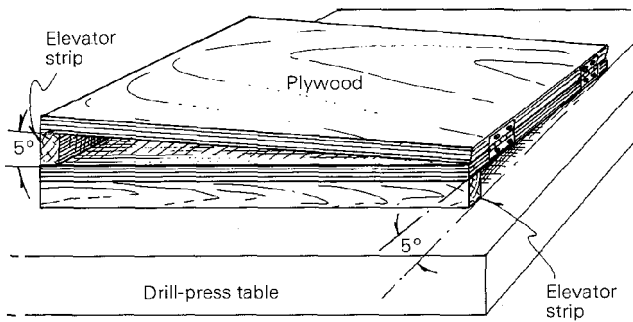

the length of the plywood piece by the tangent of 5° (0.875) and got 1.575 in., or roughly $1\frac{5}{16}$ in. I then ripped one edge of two pieces of wood, 18 in. by $1\frac{5}{16}$ in. by 1 in., to get $1\frac{5}{16}$ in. After sanding down the inside edge, I fastened each of these flush with one of the edges of each plywood piece, and hinged the two pieces together, so the angles were at right angles to each other.

I cut the legs to length, with a double 5° angle on each end, before tapering and turning ends to fit holes in the tops. Of course, the angle can be changed by just multiplying the tangent of the desired angle by the length of the plywood pieces, and using the result for the height of the elevator.

—Eugene Roth, Honeoye Falls, N. Y.

Curved edge joint

A simple system exists for making close-fitting edge joints along a curving line. This quick and reliable method works equally well for major design pieces and for rough work.

The idea is to cut both of the pieces to be joined simultaneously, as in marquetry, one above the other. The desired de-

sign is laid out on the upper one, and the boards overlapped a distance appropriate to the line. They need to be firmly but temporarily fixed in this position, by means of nails, glue, clamps, double-stick tape, etc. The assembly is then cut on the band saw with a bold and sure stroke, since any stopping and wiggling will result in a hole along the glue line. Frequently the two pieces can be held during cutting just with one's hands, doing away even with the fastening.

When the waste parts are removed, the major pieces should fit together very well. Even if the sawing went off the line, at least they match. There may be a small gap evident along the glue line where the curve is sharp. This results from the radius differential between the two sides of the saw kerf. In practice

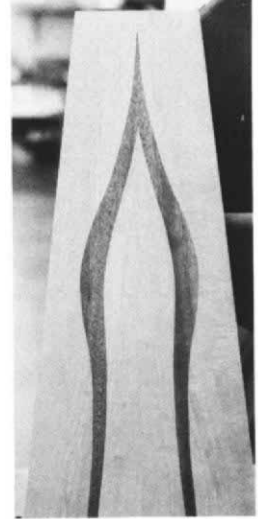
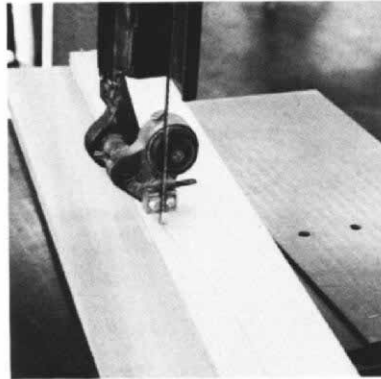

Edge joints can be cut by overlapping contrasting boards and bandsawing along the line of the design. Joint is then glued and clamped. Result, right, is a resawn and bookmatched pattern.

METHODS (continued)

this is not a problem, however, because it usually can be pulled up in gluing without undue stress. A little judicious shaving at the ends would also solve this problem.

When wide boards are cut by this technique, the upper one sometimes droops out of parallel with the band-saw table. This is prevented by tacking a filler piece along its outer edge to hold it up. Joining thick wood brings out new possibilities—the lamination can then be resawn and bookmatched.

This method is good for relatively unimportant edge-joining such as in jigs, mockups and secondary pieces. Here a strong, acceptable joint can be accomplished in a few seconds, with no concern for straightening edges, planing, etc.

—Sam Bush, Pottstown, Pa.

Picture-frame clamp

This is my no-cost solution for clamping a picture frame: Clamp all four pieces at once with a length of nylon cord. Measure the outside perimeter of the frame and tie a non-slip knot so the cord will just fit around. Then use four or more scrap blocks between the cord and the frame to stretch the cord tight and draw up the joints. Pieces of cardboard or leather folded over the corners prevent the cord from digging in. If the frame twists when tensioned, place a weighted piece of plywood on top—after you have tested the squareness of the frame. (Try the procedure dry first, to spot bad joints). On narrow frames, use eight blocks, all located near the corners. With white glue, heavy clamping pressure is not required to make a solid, lasting joint.

—Duane Waskow, Marion, Iowa

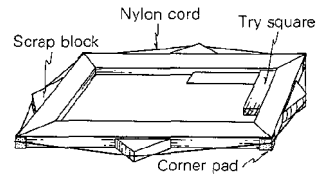

Jointing decorative strips

When fitting out a project with decorative wood strips and binding (on a guitar or violin, a marquetry frame, or a fancy box) a most difficult operation is making tight butt or miter joints between the strips—especially if the wood is white. A little jig, which I call a miter block, surmounts this problem. It will produce good, flat gluing faces on the ends of the strips at 90° or 45° (or whatever angle you design it for), and will also trim them to perfect length.

The block itself is a square of metal or dense hardwood (say 2 in. by 2 in. by 6 in.), with opposite faces parallel and all four faces mutually square. One end of the block is cut at 90° and the other at 45°. It is placed on a flat base, and the purfling (decorative) strip, rough-trimmed and marked for length, is placed (usually vertically) against the block's side and the base, and held securely in place with a straight caul. The left hand holds both block and caul so that the strip's end protrudes slightly past the end of the block. The right hand holds a small, straight sanding stick (a high-quality metal nail file is best) against the end of the block (the guide), and works the stick to and fro, sanding the end of the

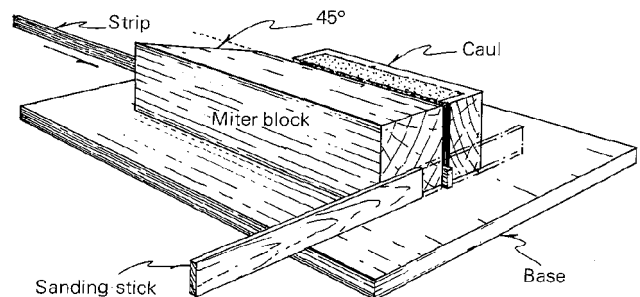

METHODS (continued)

strip until it is flush with the block's end and the length mark is reached. Sandpaper glued to the caul grabs the strip so the left hand can feed it into the moving sanding stick. The process is complicated to describe, but a cinch to carry out. By changing the orientation of the block, both inside and outside miters can be obtained. The block can be used for pearl, ivory and other inlay materials as well.

—William D. Woods, Phoenix, Ariz.

Steel-wool holder

Cut a hollow rubber ball into two pieces, one smaller than the other (for two different sizes). Into these hollow pieces place your steel wool and use, instead of final sandpaper, for finishing your woodworking projects. The rubber ball will keep the steel wool together and also keep it from sticking your fingers. I find that steel wool makes a better finish than sandpaper on the clocks I build.

For sanding round pieces on the wood lathe I use a home-made tool. I have them in different sizes. Take a piece of pipe

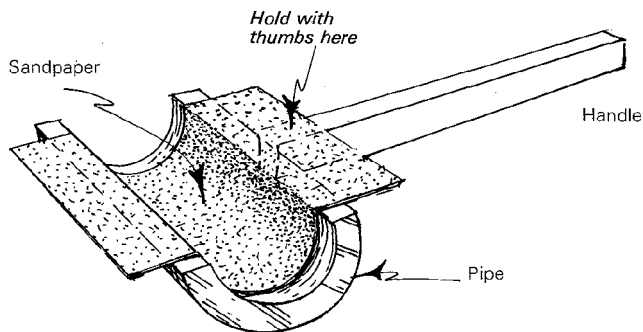

in a length to suit your needs and split it in half lengthwise, then weld a handle on it. Lay sandpaper or steel wool in the cup and hold with your thumbs back from the work.

—George Eckhart, Kenosha, Wis.

Clamping a scarf joint

A scarf joint can be securely clamped as shown: After spreading the glue, tack the pieces to be joined with pin brads (#16/18) cut to $\frac{1}{4}$ in. long. Then sandwich the pieces between

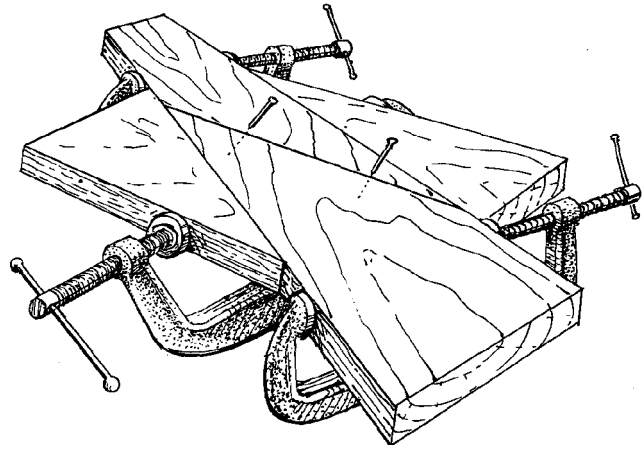

wedges made of soft, wet wood. While one C-clamp applies pressure directly on the surfaces to be joined, two others hold the wedges in position.

—Price G. Schulte, St. Louis, Mo.

METHODS OF WORK

Methods of Work is a forum for readers to exchange the tools, jigs and tricks they've devised. Send precise details, sketches (we'll redraw them) and negatives with photographs, if any. We pay at the rate of \$100 per magazine page, minimum \$20, upon publication.

Less is more

I have any number of expensive, cumbersome, time-consuming holddown clamps for carving, but this rig beats them all. I discovered it while visiting China last summer. It's an easy

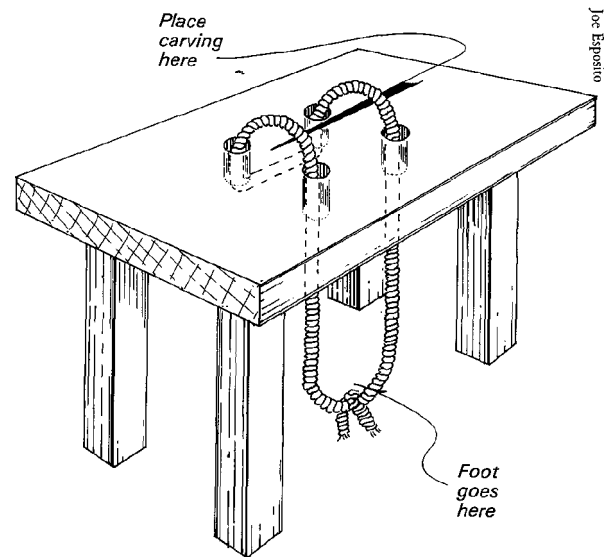

way to hold down a piece that has to be moved frequently, for carving and fine work. It even could be made deluxe with straps and a foot rest.

—W. D. Young, Scotch Plains, N.J.

Homemade clamp

An inexpensive and fast-acting clamp for securing work to jigs and bench tops can be made from a bolt, a straight mending plate of corresponding strength, a wing nut, two washers, a nut and a wedge. Choose a bolt of sufficient diameter for your application. If the wood in which the clamp is to sit is thick enough and a permanently protruding bolt will not be objectionable, a hanger bolt will make installation simpler. If you have to, enlarge the first hole from one of the ends of the mending plate to allow a loose fit with the bolt. Then bend the mending plate about 20° or so at the location of this hole.

To use, unscrew the wing nut so the work and a protective scrap piece can pass below the shorter bent edge of the mending plate. Keeping the bent section parallel to the work surface ensures even pressure and reduces the chance of marring the work. To engage the clamp, simply push in the wooden wedge.

To unclamp, first press on the thinnest part of the wedge

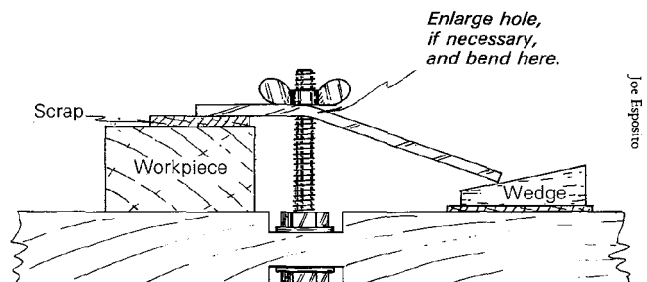

METHODS (continued)

and rotate that point far enough to let you get your fingers below the plate. Then ease the pressure by lifting up the plate and withdrawing the wedge.

—Blake Raines, Springfield, Pa.

Cleaning with shavings

Cedar shavings make an ideal cleaner for chrome or any hard finish, such as paint or varnish. They will also leave glass sparkling clean.

You can get a good supply by fine planing or by filing with a Surform, which I use. If you want to store the stuff, keep in a dust-proof container and start with a clean shingle. Or you can take a chunk about the size of a sanding block from an ordinary cedar shingle and rub a high shine on old varnish or paint that is beginning to oxidize.

In case you have some real gunk to remove, immerse a fistful of shavings in water, rub the surface clean and then finish with the dry shavings. Everything usually comes out shining.

—Robert L. Johnson, Whittier, Calif.

Checking a miter square

I am getting weary of buying 45° miter squares from mail-order catalog firms and receiving ones of 44° or 46° instead. Veneering does not permit such a variance. The angle of a miter square can be checked with a perfect straightedge (a wide piece of carefully jointed ¾-in. maple will do) and a draftsman's triangle with an angle of exactly 90°.

First (A) place the miter square against the straightedge, as shown in the drawing at the top of the next column. Then (B) position the 90° angle of the triangle against the extended leg of the miter square. With the triangle secured, (C) flop the miter square to the other side of the triangle. Slide it against

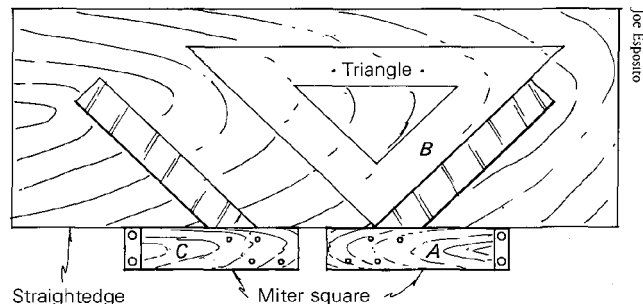

the straightedge until it meets the triangle. Any resulting angle between the miter square and the triangle is twice the error angle of the miter square.

—C. Edward Moore, Bowie, Md.

Roughing out bowls

It is frequently suggested that in bowl turning, one should cut from large diameter to small diameter. I would like to call attention to a situation where the opposite may be preferable—this is the case when roughing the outside of a bowl with the faceplate attached to what will eventually become the top of the bowl. The method evolved from turning green bowls, where cutting from large to small diameter can be a jarring experience.

For inboard turning, I rough the outside of bowls with my back to the lathe, and thus with the headstock to my right. I cut with a deep gouge. Holding the handle in my left hand and resting the butt on my right hip steadies the gouge and supplies considerable power. I work from the base to the side

METHODS (continued)

of the bowl, slowly rounding over the nearest corner. The cut goes from small to large diameter with great ease and in my opinion, it's a case of "cutting wood as it prefers to be cut."
—Wendell Smith, Fairport, N. Y.

Sanding device

To sand holes or a flat surface, take a 1/4-in. rod—the length depends on the depth of the hole or the width of the surface. Cut a slot down the center to hold a piece of sandpaper. Cloth paper is best, and you can use old sanding belts. Then

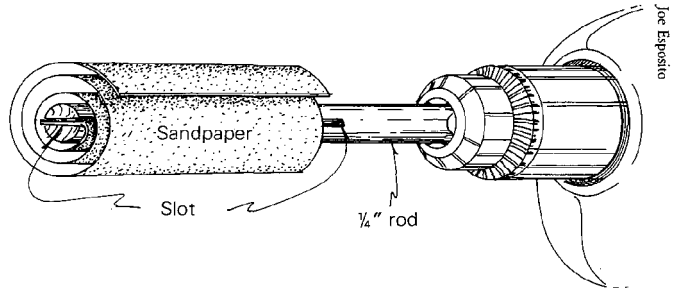

chuck the rod in a 1/4-in. electric drill. Make sure the paper is wound the right way. The paper sands as it flaps. When the edge wears, it can be trimmed off.
—T. L. Trudell, Saginaw, Mich.

Bleaching walnut

Antique walnut furniture is usually a fairly even light brown color. I have had the problem of matching this color when replacing broken or lost parts with local walnut, which is dark

METHODS (continued)

brown and heavily streaked. My solution is to sand the entire piece rather heavily to remove scratches and discoloration. Then I cut and sand new parts to final fit, and bleach them to a cream color with Blanchit wood bleach (available from Constantine's, 2050 Eastchester Road, Bronx, N.Y. 10461, at a cost of \$4.10 for a 2-pint kit) taking care to protect my hands, face and eyes. Then I boil a batch of old walnut hulls in water to cover, let them steep some time to reduce the amount of water to about $\frac{1}{2}$ the original amount, cool and strain. This makes a weak stain. I apply as many liberal wetting coats as needed to match the old wood.

—Albert J. Gnaedinger, Pocahontas, Ill.

Drilling a dowel

If you have a lathe, it's easy to bore a centered hole in the end of a dowel. You can also do it on the drill press or radial arm saw, if you have a drill bit the size of the dowel to be bored and a block of scrap wood. First clamp the scrap underneath the drill chuck, and bore a hole the size of the dowel. Without disturbing the block, press the dowel into the hole. Change to the smaller bit and drill your hole—it's automatically centered.

—Larry Green, Bethel, Conn.

Blocks for pipe clamps

To avoid the frantic search for clamping blocks while gluing up, I have designed blocks that remain in place on my pipe clamps. I cut a hole in the block the same diameter as the

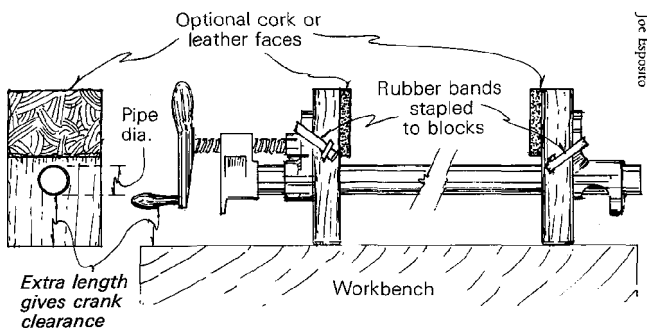

pipe. The block slides onto the clamp and is held in place with a rubber band, making it easy to remove. I made the blocks longer on the bottom to allow for the swing of the crank when the clamp is set on the bench and tightened. The blocks extend above and beyond the clamp to distribute pressure over a wide area, and to make a wider base for the clamp to rest on when set on the workbench.

—David Raynalds, Eugene, Ore.

Poor man's mallet

If you have an old baseball or softball bat stashed in the attic, then you also have a first-class hickory or ash mallet. Cut a tapered section about 15 in. long from the middle of the bat, such that the smaller end fits your grip comfortably. My own mallet tapers from $1\frac{1}{8}$ in. at the handle tip to 2 in. at the head. This long mallet is shock-resistant and will replace the usual assortment of carver's mallets, since by regulating the position of your grip on the handle, you can in effect vary the hitting weight of the head.

The head of any mallet, including the bat mallet, can be saved from inevitable flaking and checking. Cut a piece of thick, stiff, unoled leather large enough to wrap around the entire head. Dampen the leather until pliable, then finish the fitting on the head, stretching the leather and making a reasonably good joint where the edges meet. Glue the leather

METHODS (continued)

on the head with water-based glue, using tacks to hold the joint (leave the heads proud). After complete drying, remove the tacks and trim the leather down to the head. A mallet treated in this manner should never need replacing—the leather is incredibly tough and will not lift away.

—William D. Woods, Phoenix, Ariz.

Repairing turned pieces

My method for repairing a broken Windsor chair leg leaves most of the original intact, though some might say that it is as much work as turning a whole new piece. (1) The damaged part of the leg is cut off on the table saw, and the exposed

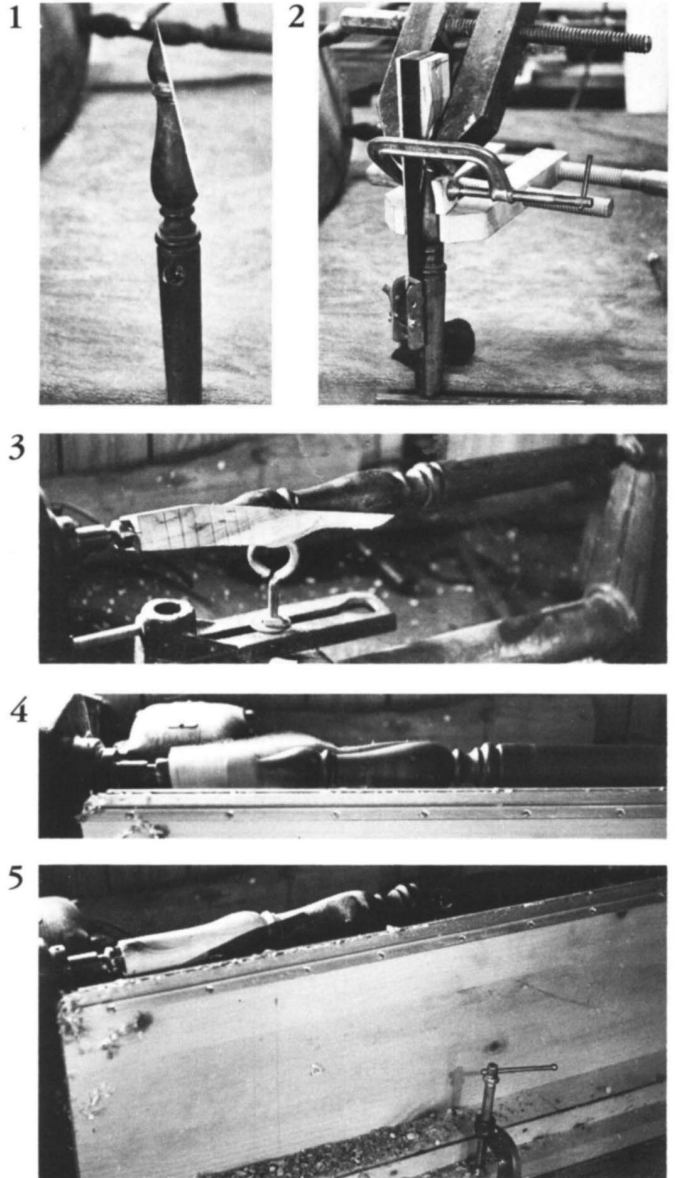

diagonal face is made flat and true on the belt sander. (2) Then I glue on a piece of similar wood, keeping the grain parallel. I use yellow glue and a band clamp to keep the scarf joint from sliding. (3) The scarfed piece is bandsawn to rough shape and centered on the lathe. (4) The proper outline of the turning shows at the overlap as the piece revolves. (5) The completed turning, before staining and finishing. To avoid having to move the tool rest along the lathe bed, I replace it with a long piece of plywood that runs the length of the lathe. To this I fit a metal edge at about the same height as a line between points in the headstock and tailstock.

—Albert C. Landry, Richmond, Maine

Methods of Work

Methods of Work is a forum for readers to exchange the tools, jigs and tricks they've devised. Send precise details, sketches (we'll redraw them) and negatives with any photographs. We pay at the rate of \$100 per magazine page, minimum \$20, upon publication.

Beam compass

A beam compass is a handy tool, but trammel points are expensive to buy. My own version costs less than \$2 and takes about two hours to make. The beam is milled from two pieces of $\frac{1}{2}$ -in. Baltic birch plywood, $1\frac{3}{4}$ in. by whatever length you want. The dado for the nut to slide in is cut to the inside of

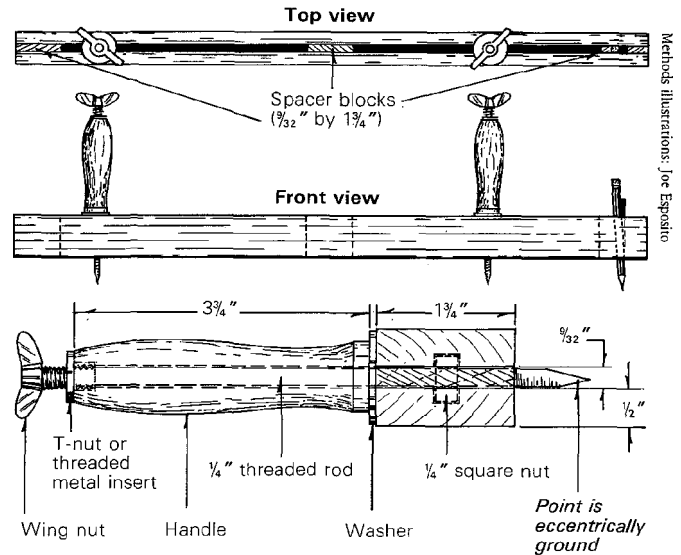

both pieces. The sides of the beam are joined at the ends and on center with three spacerblocks $1\frac{3}{4}$ in. square. In one of the end blocks drill a $\frac{1}{16}$ -in. opening, in which a pencil will be wedged.

The handles can be turned from maple, birch, beech or similar hardwood. Drill a $\frac{9}{32}$ -in. hole for the rod, and insert a $\frac{1}{4}$ -in. T-nut in the top. The rods are $\frac{1}{4}$ -in. dia. by at least 8 in. Allow extra threading for resharpening the point, because this is not tempered steel. Grind the point eccentrically (off center) for fine adjustments. Then solder a wing nut on top of the rod.

Now thread the rod through the T-nut in the handle and the square nut that rides in the dado cut into the beam until the point is exposed about an inch on the underside of the beam. Slide both points to the desired arc ($\frac{1}{8}$ -in. tolerance), then tighten the handles. With the wing nuts, you can fine-adjust the radius to the exact dimension. To mark with the pencil, raise one of the points above the pencil point. The only radius you can't get is from the pencil to the center block. In this case I remove one of the points and thread the pencil through the square nut by pushing down and twisting at the same time. The beam compass can also be used as a panel gauge if you attach a fence to the end.

—Michael Lynch, San Francisco, Calif.

Invisible edge joint

When I edge-join hardwood boards, I plane the edges by eye, then do one additional step—a technique I borrowed from the dental practice used to fit teeth and plates together. With the boards flat on a workbench, I fold ordinary typewriter carbon paper, place it between the edge surfaces and rub the

Methods of Work *(continued)*

boards back and forth against each other. Any high spots or edge misalignments show up as black smudges. I snick them off with a plane set to cut a very fine shaving. Then I repeat the procedure until I have an even smudge all along the edge. The result after gluing is a joint that is almost invisible, except for differences in grain pattern.

—James V. Ralston, Murray Hill, N.J.

Spoke-hole jig

Here is a simple jig for drilling evenly spaced holes in turned goods. To make the jig, turn a dowel on one end of a scrap block to fit the hole in the tool-rest holder. Drill a guidehole through the block. To use the jig, mount the block in the tool-rest holder and lock in place at the right position. Drill into the work through the guide hole. Use the lathe indexing

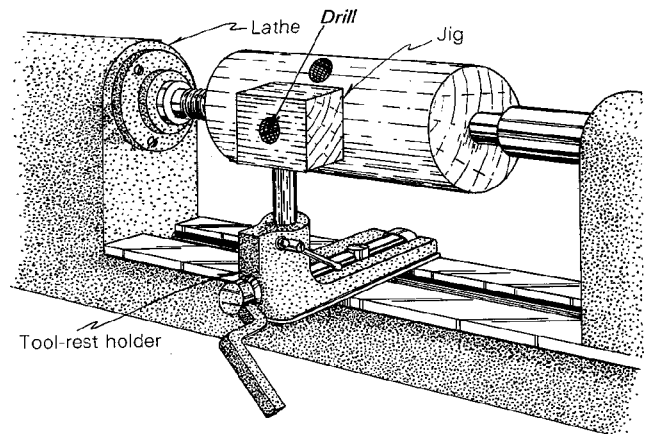

Methods of Work (continued)

to hold the work and space the holes correctly.

—*Jim Richey, Houston, Tex.*

Clamp cushions

Octagonal pipe-clamp cushions of $\frac{3}{4}$ -in. plywood with a hole in the middle eliminate the need for awkward

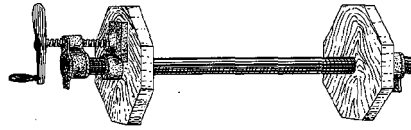

gluing blocks. The octagonal shape keeps the cushions from rolling.

—*Thomas R. Wood, St. Paul, Minn.*

Holding dogs

For those woodworkers who want to use a piece of hardwood in place of ready-made bench dogs made of metal, there is a problem of holding them in the rectangular hole in the workbench. A

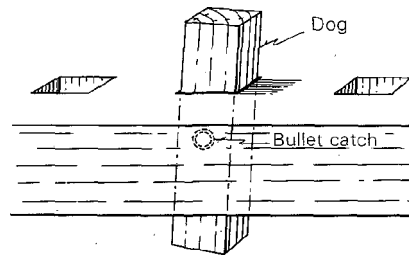

perfect solution is the bullet half of a bullet catch. The spring inside the bullet exerts enough force to hold the dog in place.

—*Edmund H. Anthon, Akron, Ohio*

Dovetail template

This homemade dovetail template was found among my deceased grandfather's effects. Its origin is uncertain,

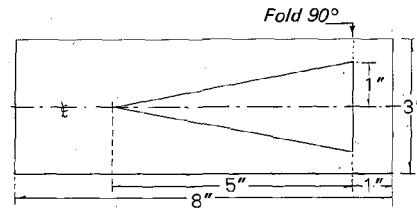

but it's permanent and probably better than a bevel gauge. It can easily be duplicated with a 3-in. by 8-in. piece of thin aluminum (an offset printing plate is the right thickness), a steel rule and an X-acto knife. Draw a line 1 in. from and parallel to the bottom edge, then scribe a triangle with the desired tail and pin angles (I use a 1:5 slope). Cut out the triangle with the knife, us-

Methods of Work *(continued)*

ing the rule as a guide, fold the aluminum at the base of the triangle, and there's your template. The triangle may be truncated at its top to leave a shorter piece to work with.

—*Roger Schroeder, Amityville, N.Y.*

Removing excess glue

Very often excess glue is not discovered until stain is applied to a project. Then it is not only difficult to remove, but the stain tends to appear darker in the spot where the glue was removed. This is especially true for polyvinyl resin (white) glue, which dries transparent and is difficult to see.

Many of us were taught years ago that excess glue around a joint or on the surface of stock should be wiped off with a wet rag. This is one of the worst things to do—it tends to dilute the glue and washes some of it into the pores where it cannot be sanded off. A better solution when gluing stock together is to allow the glue to gel for five or ten minutes, then scrape it off with a putty knife. Excess glue in difficult-to-clean areas, such as leg and rail joints where the rail or apron is set in from the edge of the leg, presents a challenge, especially for the beginner. A method I use is to dry-clamp first, apply a thin coating of paste wax around the outside of the joint, then remove the clamp, take the joint apart, apply the glue and reclamp. When the glue has dried the excess can easily be removed by lifting with a putty knife or chisel. The wax can be cleaned by washing the area with paint or lacquer thinner, or cleaning solvent. All will remove the wax without raising the grain or staining the wood.

Another good practice prior to staining that will make defects such as glue stains, dents or scratches stand out is to wipe the entire project with a rag that has been saturated in paint or lacquer thinner, or cleaning solvent. The defects should be noted by marking lightly with a pencil. When the surface is dry the areas can be scraped with a hand scraper and/or sanded.

—*Eric Schramm, Los Gatos, Calif.*

Fitting a froe handle

In splitting out billets, the froe is used for wedging, levering and sometimes even chopping. The handle must be fitted very securely to withstand the different strains caused by these varied functions. A traditional froe has a tapered eye, and the blade was slid over the handle like an adze or mattock. Froes sold by modern suppliers have cylindrical eyes, and the handle is usually held on by a wedge, as on a

Methods of Work (continued)

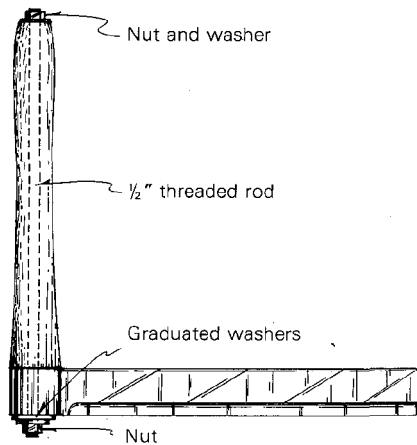

hammer. I've had trouble keeping the handle on using both these methods.

I solved this problem by passing a $\frac{1}{2}$ -in. threaded rod through a hole bored lengthwise through the handle. Nuts on both ends of the rod pull the eye of the froe firmly against the shoulder of the handle. I use hornbeam for my froe handles but oak, ash or hickory would do as well. Before turning a handle to shape, I bore it using a $\frac{1}{2}$ -in. shell auger on the lathe. Boring may also be done by hand using a long electrician's auger, which will chew right through end grain if the spurs are ground off. The handle is then chucked in the lathe centered on the bore, and turned to shape. The tenon is turned to a snug fit in the froe eye, and its length trimmed short of the bottom of the eye. The handle may be tapered back from the shoulder to make a comfortable grip, but avoid a sudden taper that would weaken the shoulder's ability to resist the tension of the threaded rod. A stack of graduated washers is needed to cover the end of the froe socket on the bottom end of the threaded rod.

—Richard Starr, *Thetford Center, Vt.*

Less is more

Old shoes nailed to the wall make great file holders.

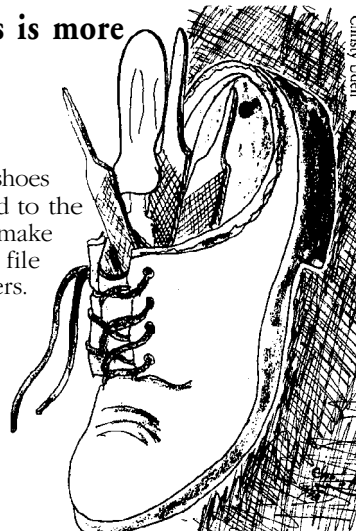

—Christy Udell, *Santa Rosa, Calif.*

Methods of Work

Miter jig

With this fixture I can make tight, clean production-run miter cuts on my radial arm saw. Those of us who can't always take time to readjust and tune our saws realize they work out of true. The miter jig overcomes this because any error on one piece is compensated by matching error on the other.

To make the jig, glue and screw two 1x2s to a sheet of 1/4-in. plywood about the size of the saw table. The 1x2s are fast-

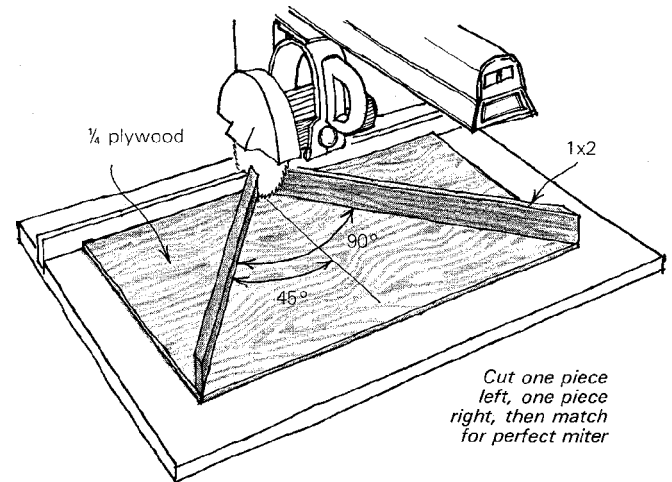

ened 45° from the line of the saw cut. Care with the orientation of the miter fences improves the device—a 45° plastic drafting triangle will be helpful. The fixture can be clamped to the saw table or made as part of a permanent fence.

To use, clamp the fixture on the table (or in the fence channel if the fixture has a permanent fence). Cut one piece left and one piece right. Match these cuts and a perfect fit will result.

—C.H. Dimmick, Sparta, N.J.

Taping bowls to faceplate

I use a faceplate-fastening method for shallow bowls or dishes for faster and cleaner separation of the finished piece from the faceplate. There is no glue and paper to remove as when the work is glued to a piece of scrap wood with paper between. Nor are there any screw holes to fill as there are when the faceplate is screwed directly to the turned piece.

Screw the top side of the turning blank to the faceplate and turn the bottom of the dish with a recess to accept a wood chuck. After the bottom of the dish is sanded, I apply a polyurethane finish. Next, attach a scrap block of wood to the faceplate and turn it until it fits snugly into the recess on the bottom of the dish. Apply masking tape to the bottom of the dish over the recess in a single layer. Rub the tape with your fingernail to remove air bubbles. Now glue the scrap wood

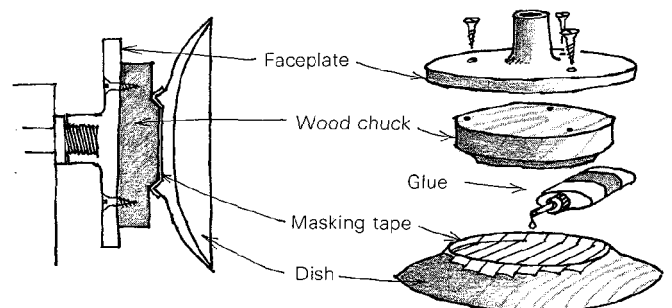

chuck (which should fit snugly in the recess) to the taped recess in the bottom of the dish. When the glue is dry, mount the dish-faceplate assembly on the lathe and finish turning.

To remove the dish from the scrap wood chuck, place the chuck in a vice, and, using both hands, gently twist the dish until it separates from the chuck. Alcohol will remove any adhesive left from the masking tape.

—Dennis Castagna, Southfield, Mich.

Homemade froe

The froe is a traditional tool for cleaving green wood that's enjoying a revival due to a renewed interest in "country" woodcraft. But the tool is rarely found through antique tool sources (I've never seen one) and new froes cost \$23. Fortunately, for those of us with more time than cash, an excellent froe can be forged from a discarded auto spring.

Old leaf springs are easy to find behind auto garages and in junkyards. The springs are about the right thickness and width for a froe and are excellent steel. The bottom leaf of the spring cluster has an eye on each end. This is the leaf you're looking for—the eye serves as a ready-made handle socket.

To make the froe, cut a 10-in. to 12-in. section off one end of the leaf, straighten the curve, and forge or grind in a knife-

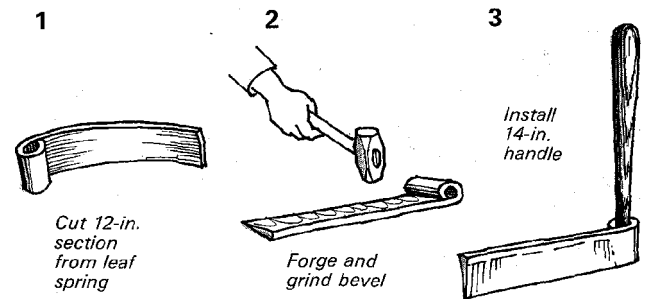

like bevel on one edge. Lacking blacksmithing tools, I cut the spring with an oxyacetylene cutting torch (an abrasive cut-off wheel would have worked as well). Then, with a helper to hold the torch, I heat the blade red hot, forge a bevel on one edge and straighten the curve on a makeshift anvil. The bevel is completed on a grinder. Next, I harden the blade in oil and temper to light blue. A 14-in. black locust handle driven in the handle socket completes the froe.

A more skillful blacksmith probably would have enlarged the smallish socket and bent it to be in line with the blade. These operations seemed beyond my skill and equipment. But, in using the froe, the socket size seems adequate and the offset increases splitting leverage in one direction.

—Larry Joseph, Aha, Okla.

Cutting circles—revisited

I made Larry Green's band saw circle-cutting jig as described in *Methods of Work* (Spring '77). I found it was difficult to set blanks on the jig in the desired center. So, I built a pivoting jig that solves this problem and has other advantages.

The jig, made of plywood, has a base, a pivot board and a stop glued to the base. To use, clamp the base to the saw table so that the pivot pin and the circle holes are lined up with the front of the saw blade. Pull the pivot board off the base, install a pin in the desired circle hole and center a blank on the pin. Fit the pivot board back on the base, swinging it back clear of the saw blade. Now start up the saw and swing the pivot board into the saw blade, which will cut a reverse circle in the scrap area of the blank. When the pivot board hits the stop, rotate the blank to cut the circle.

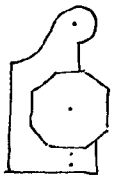
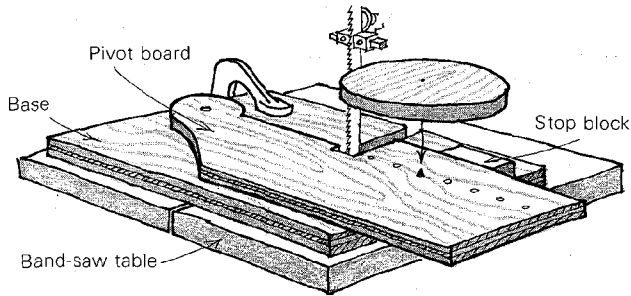

Place blank on pivot

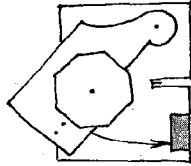

Swing pivot into saw

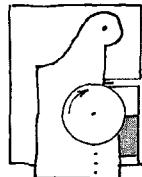

Turn blank

An advantage of the jig is the ease of changing circle diameters. Just pull off the pivot board and reposition the circle center pin—there's no need to remove the whole unit.

—Jerry Elvin, Nezperce, Idaho

Setting a saw fence

I have always found it awkward to set the rip-fence of a table saw parallel to the blade using a ruler or tape measure, because I have to crane my neck over the saw table to read the measurement at the back of the blade. Also, using both edges of the tape or ruler, which may not have the same unit of measurement, can cause confusion. I now use a large set of inside calipers with a maximum extension of 12 in. for cuts within that range. I have ground the tips of these calipers to give a minimum reading of $\frac{1}{4}$ in. The calipers are set to the desired width of cut, and by alternately placing them between the fence and the front and rear of the blade, I can not only see any necessary adjustment but also feel it.

—Kent McDonnell, Newcastle, Ontario

Sheet metal screws faster in wood

As builders, "time is money" to my brother and me. We've discovered that replacing standard wood screws with Phillips-head sheet-metal screws results in a faster and stronger job in building applications. I have never felt the standard wood screw had the strength we needed. So, we started using pan-head sheet-metal screws which, because of their deep thread and straight shank, had greater holding power, but couldn't use them for all applications because of their appearance.



Sheet-metal screw

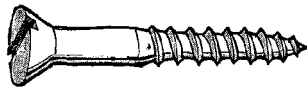

Wood screw

Then by accident, one of our carpenters brought a box of flat-head Phillips sheet-metal screws on the job. Since then we've used nothing else. On an average house we use 2,000 screws. We fit a commercial-duty $\frac{3}{8}$ -in. variable-speed drill with a Phillips Yankee Screwdriver bit and start plugging away. This approach is fast, easy and gives strong results.

I don't understand why sheet-metal screws aren't a standard in woodworking procedure—perhaps it's because many

lumberyards and supply houses don't carry the screws. Sheet-rock screws are similar (they have a finer thread) but are also relatively hard to find.

—Jeff Tallman, Weston, Conn.

EDITOR'S NOTE: Screw manufacturers and fastener suppliers echo Tallman's observation. A representative of a Chicago-based company commented that sheet metal screws are made of stronger, case-hardened, medium-carbon (1022) steel. The threads are "rolled," which results in denser, stronger work-hardened threads. Metal screws typically have one or two more threads per inch and are threaded right up to the head. On the other hand, wood screws are made of soft, low-carbon (1010) steel. Threads are "cut," which "opens the pores" of the steel and results in weaker threads. The representative felt the unthreaded shank was more of a nuisance than a benefit. His personal opinion was "wood screws are inferior—the only reason they continue to be used is ignorance."

One disadvantage of metal screws is that, in continuous use, the case-hardened heads eat up the drivers, but the case-hardening step can sometimes be skipped on special request to reduce driver wear.

Shoe-polish stain

Ordinary wax-based shoe polish makes a good stain and filler for open-grained woods such as walnut and oak. In a small jar, mix a chunk of polish with enough turpentine to liquefy, then rub the liquid in and wipe off as you would with regular stain. Several shades are available—I like the black with walnut. The coating won't interfere with subsequent finishing.

—Carl R. Vitale

Reversing switch

Occasionally I find it necessary to reverse the motor on my Sears shaper and other tools. But reversing switches are expensive (\$39 for the one Sears sells) so here's how I made my own for \$1.59. Buy a 10 ampere, 125 volts a.c. double-pole, double-throw switch from an electronics supply house (I used Radio Shack Cat. No. 275-1533). Refer to the motor instruc-

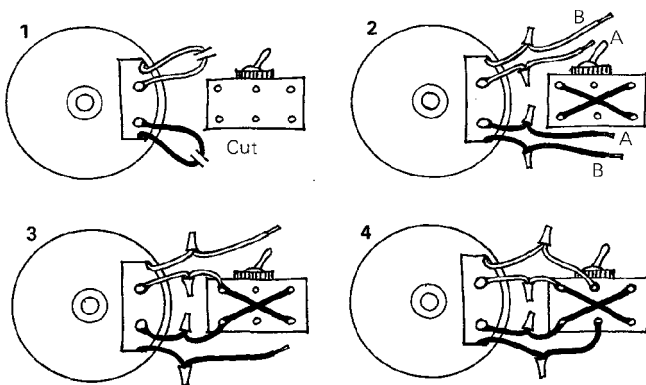

tion manual to locate the wires that can be switched to reverse the motor. You'll splice the switch into these so cut them and add 6 in. or 8 in. of #16 wire to each end. This gives you two sets of wires which are labeled set A and set B in the diagrams. Cross-connect opposite end posts on the switch. Then connect set A to one set of end contacts on the switch and set B to the center set of contacts on the switch.

The whole project takes only about 45 minutes. The 10 amp switch is really overrated—but safe.

—Jon Gullett, Washington, Ill.

Methods of Work is a forum for readers to swap tips, jigs and tricks. Send details, sketches (we'll redraw them) and negatives with photos to Methods, fine Woodworking, Box 355, Newtown, Conn. 06470.

Methods of Work

Jig for cross-grain routing

The concept is simple, but this jig is indispensable for routing dados in carcass sides, especially when several dados are to be made in one board. Once the jig is clamped together you can slide it quickly into position for the next cut.

Make up two L-shaped pieces with 4-in. wide plywood strips. Cut the shorter pieces of the L 16 in. to 18 in. long (router base plus 8 in.) and the longer pieces 20 in. to 30 in. long (widest carcass plus 8 in.). Face-glue and screw the pieces together taking care to maintain a 90° angle.

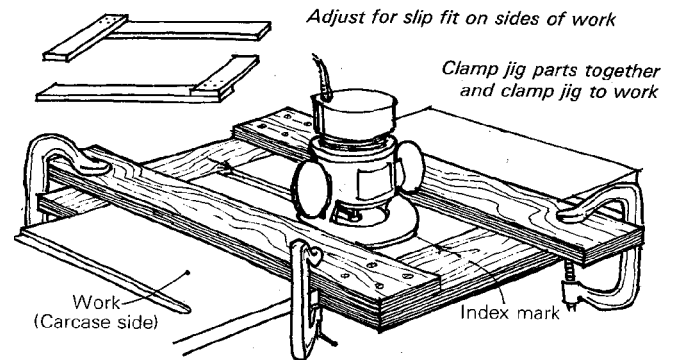

To use, place one L on the front edge of the board to be routed and one on the back edge so that the two Ls form a woven rectangle as shown. Adjust both directions to give a slip fit against the router base and against the sides of the board. Then clamp at the intersections of the two Ls. Pencil in an index mark on both sides of the jig to simplify lining up for a cut. Clamp the jig to the board before routing the dado.

—Roger Deatherage, Houston, Tex.

Tin-can drying oven

If you have a stack of wood air-drying in the shop, chances are you have used this test to determine the moisture content of the wood: Cut a small sample from the wood, weigh the sample (I use a caloric scale), then dry the sample in the kitchen stove (until it doesn't change weight). Percent moisture is then calculated by dividing weight loss by final weight.

Unfortunately, the procedure ties up the oven for a day and, depending on the species being dried, fills the house with a disagreeable odor. These problems can be eliminated by a simple and inexpensive oven made from tin cans and heated by a 25-watt light bulb.

The model shows a 2-lb. coffee can (5 in. dia. by 6½ in. tall) as the inner container, and a large photographic-film container (7 in. dia. by 12 in. tall) as the outer container. The size and shape of the cans are not important—just so there's enough room for the wood samples and at least 1 in. of space between the inner and outer cans. Fill this space with fiberglass wool to retain the heat.

In operation, the heated, moist air rises through the chimney and is replaced by outside air drawn through the three tubes at the bottom. After a 20-minute heat-up period, adjust the temperature to about 112°F to 120°F by opening or closing the damper in the chimney. If the outside air temperature does not change drastically, the temperature inside the oven will remain relatively constant over the 24-hr. drying period with no need for a thermostat.

To solder the parts together, first file the surfaces clean,

Methods of Work is a forum for readers to swap tips, jigs and tricks. Send details, sketches (we'll redraw them) and negatives with photos to Methods, Fine Woodworking, Box 355, Newtown, Conn. 06470.

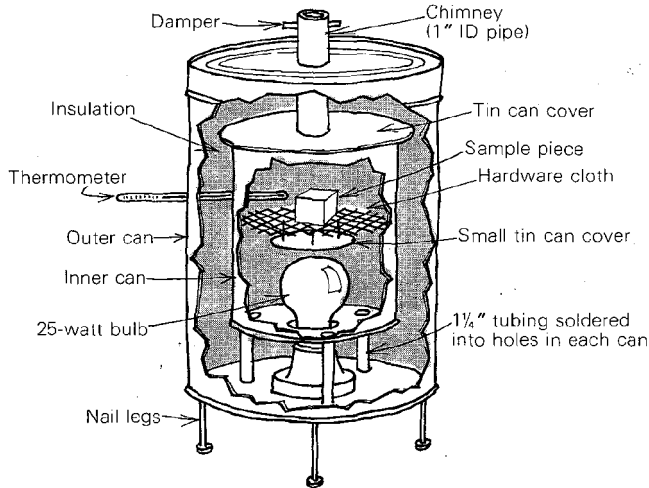

and tin with solder. Use soldering paste or acid as flux. Since tin cans are already tinned, soldering is easy.

The illustrated oven is designed for rather small wood samples. If you want to dry larger samples, the same design can be scaled up to a larger oven requiring, perhaps, a 40-watt or larger light bulb.

—H. Norman Capen, Granada Hills, Calif.

Toolmaker's clamp

I've seen several wooden clamp designs presented in the "Methods of Work" column—but none similar to what machinists know as a toolmaker's clamp. It is constructed like a standard wooden clamp but uses fixed bearing surfaces in place of the left-handed threaded rods and barrel-nuts. Because the toolmaker's clamp uses standard hardware-store threaded rod, it is much easier to build. Only a right-hand tap and drill bits are needed to complete the metal work.

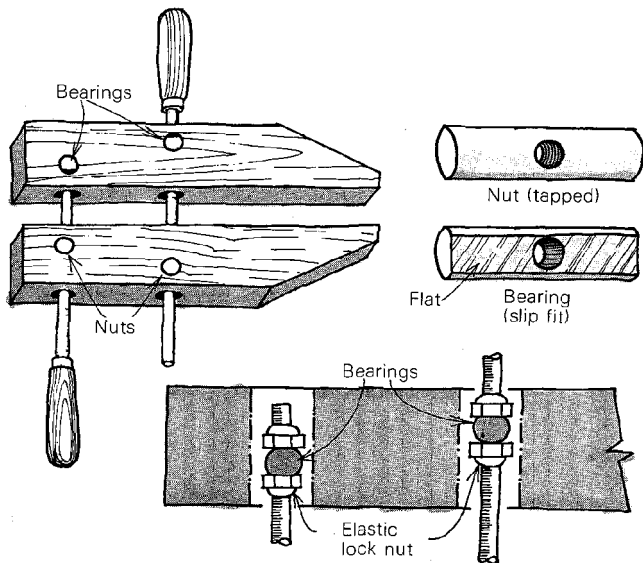

Although the barrel-nuts can be made from either brass or steel, make the bearings out of brass (steel would soon gall the thrust surfaces). File a flat on each of the two bearings and turn the flat toward the side that takes the thrust. The thrust-nuts that bear up against the bearings must be locked into position on the threaded rod. I have found that elastic lock-

nuts work well, but a pair of jam-nuts or a single nut brazed to the threaded rod could be substituted.

Both barrel-nuts must be located in one jaw and both bearings in the other jaw to get the standard tightening and loosening rotation. It will take twice as many turns to close the toolmaker's clamp, but you get twice the clamping force for the same tightening torque.

—Larry Pagendarm, Santa Clara, Calif.

Reproducing honing angles

Honing chisels and plane irons is facilitated by using a honing guide that clamps the tool and maintains the right sharpening angle between the tool and the stone. But it is difficult to set the tool in the guide at the same angle time after time.

I solve this problem by using a "magnetic protractor" (also called an "angle finder"). In its simplest form, the tool consists of a magnetic base and a movable part containing a bubble-level vial. A pointer on the movable part indicates the angle (from horizontal) on a protractor scale in the base. A similar (but more expensive) version is based on a spring-mounted pendulum that keeps the pointer vertical. Magnetic protractors are not commonly found in hardware stores but are available through Sears, Silvo Hardware and others.

To use, set the pointer to the desired angle and attach the magnetic base to the tool to be honed. Then, with the tool in the honing guide, adjust the angle between the tool and the stone until the level bubble is horizontal.

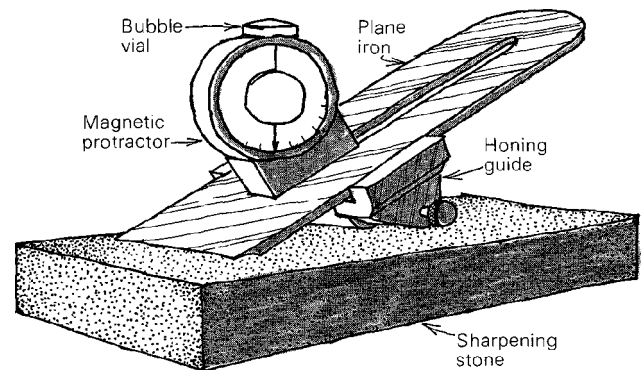

The honing surface should be flat and level for the above procedure to work. If the honing surface is not level, use the magnetic protractor to level it.

—H.E. Brandmaier, Harrington Park, N.J.

Trueing framing squares

Here's a method for trueing a framing square using just a hammer and center-punch. First test to determine if your square is true by drawing a straight line three to four feet long. Then, with the tongue on the line, draw a pencil line alongside the blade. Flip the tongue over and bring the square into the corner of the two lines just drawn. If the square is true, the lines will be right alongside both tongue and blade.

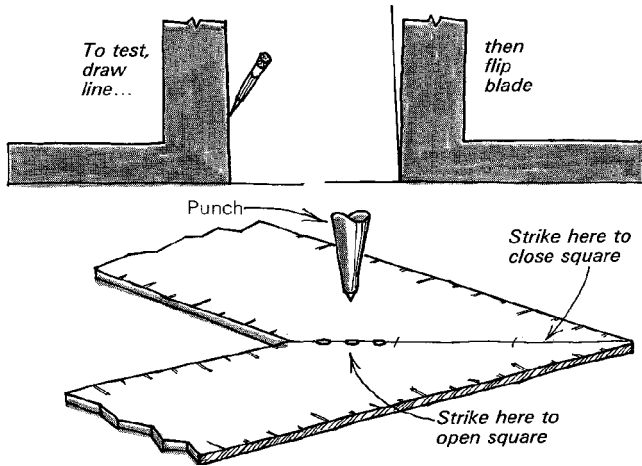

But if the lines don't coincide, here's how to regain a true 90°. At the heel, draw a line from the inside corner to the outside corner and divide the line into thirds. Place a center-punch on the line in the center of either the inner third or the

outer third. By striking the punch in the outer third you spread the metal and cause the square to close (decreasing the angle). By striking the punch in the inner third you will open the square (increasing the angle). Rap the punch smartly with a hammer, as you would to leave a starting hole for a drill. Naturally, check the square after each adjustment is made.

—Robert C. Amirault, South Thomaston, Maine

Cutting dovetails on the scroll saw

Traditional "hand" dovetails can be cut quickly and accurately on the scroll saw or band saw. The scroll saw gives a finer, more accurate cut than the band saw—especially if a thin, 32-point blade is used.

First, lay out the pins following the traditional method. Cut one side of the pins by tilting the scroll-saw table to the proper angle (8° to 14°). Then tilt the table the other way, cut the other sides of the pins and chop out the waste between pins with a chisel.

Some saw tables (especially on band saws) don't tilt in both directions. This problem is easily solved by building a clamp-

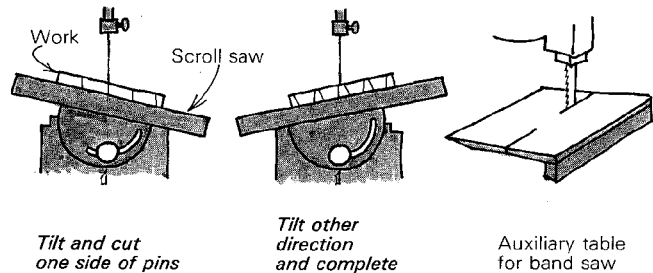

on auxiliary table that can be reversed to get both angles.

The tails, scribed from the pins, are easily cut by returning the saw table to the horizontal position. By sawing away most of the waste between the tails, only a bit of chisel work is needed to complete the joint.

—Gustave Kotting & David Haber, Grantsville, Md.

Clamping splined miters

Here's an improved clamping block for spline-miter joints. My set has been used to make at least a hundred joints.

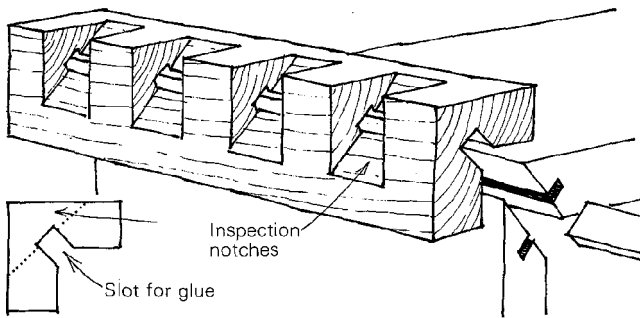

The glue block is basically an L-profile block with two additions—a channel cut in the inside corner to allow for exuded glue and a series of inspection slots cut into the outside corner of the block to see if the joint is pulled together evenly. The blocks can be used with strap or bar clamps.

—R.H. Norton, Shalimar, Fla.

Holding irregular shapes

A simple pegboard table will help hold irregular shapes in place. All you need is a sheet of 1/4-in. pegboard for the top, a can of 1/4-in. dowels in various lengths and a can of softwood wedges. Put the work anywhere on the pegboard, press in the dowels around the piece and take up the slack with the wedges.

—Dennis J. Teepe, Lawrence, Kan.

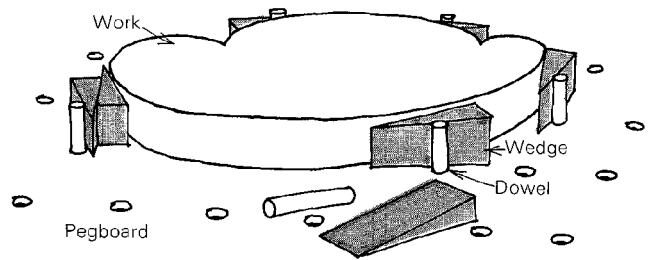

Shine, Mister?

When a finish is just "not quite right" I've found that a good stiff shoe brush used with fine abrasive powder can work wonders. Sprinkle a small quantity of either pumice, rottenstone or tripoli (depending on the desired effect) on the piece and brush vigorously with the grain. The sheen of a finish can be blended and evened out—light scratches and imperfections can be erased. Select finer abrasives for a glossy finish and coarser abrasives for a satin sheen. I have obtained better

Methods of Work (continued)

results faster with this method than with steel wool, oil or water hand-rubbing, and so forth. The technique can be used on oil, wax, lacquer or even French-polish finishes.

A shoe brush can also be used to embed grain accents such as red and white lead, Prussian blue, lampblack or malachite. Brush the accent in, wipe off the excess with the grain and seal—that's all that's necessary.

It's important, however, to use a natural-bristle, thick, clean brush of the highest quality. I use an old pure badger brush that I wouldn't trade for anything—well, maybe for some walnut or rosewood or....

—Christian Albrecht, Allentown, Pa.

Clothespin clamps

I make heavy-duty clothespin clamps from two hardwood sticks ($\frac{1}{2}$ in. square by 7 in. long), a short $\frac{5}{8}$ -in. dowel fulcrum, and a heavy rubber band (about $\frac{1}{4}$ in. by 4 in. long). The dowel fulcrum fits in slight hollows filed in the sticks about one-third the way from the front. Dull the sharp edges of the sticks, then double the rubber band around the two sticks in front of the fulcrum as many times as possible.

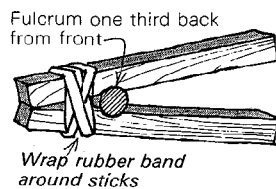
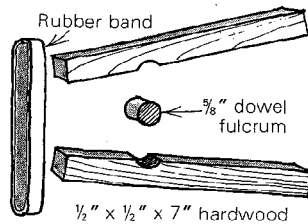

I use this clamp as described for gluing the linings onto the sides of musical instruments. But by making a few changes the same basic clamp can be used for other applications. For example, different jaw capacities or parallel-jaw clamping can be achieved by using different sized fulcrums. The weight of the rubber band can be varied for more or less clamping pressure. The jaws can be notched to clamp unusually shaped work.

I also have some commercial steel-spring clamps but my homemade clothespins clamp with more pressure.

—Bart Brush, Cherry Valley, N.Y.

Methods of Work

Table-saw tenoner

This jig, designed to cut tenons and bridle joints on the table saw, performs as well as expensive, commercial versions.

It consists of a base, which travels in the miter gauge slot, and a fence assembly. Dadoes in the fence assembly slide on rails in the top of the base to allow the blade-to-fence distance to be varied. The two pieces are locked at the right position by a nut mortised in a block of wood. Make the other jig parts of high-quality $\frac{3}{4}$ -in. aircraft or hardwood plywood; don't waste your time with fir plywood.

To use the jig, clamp the work to the fence with a C-clamp, or a hold-down clamp mounted on the fence. Align the jig for the cut and push through the saw.

—Larry Humes, Everson, Wash.

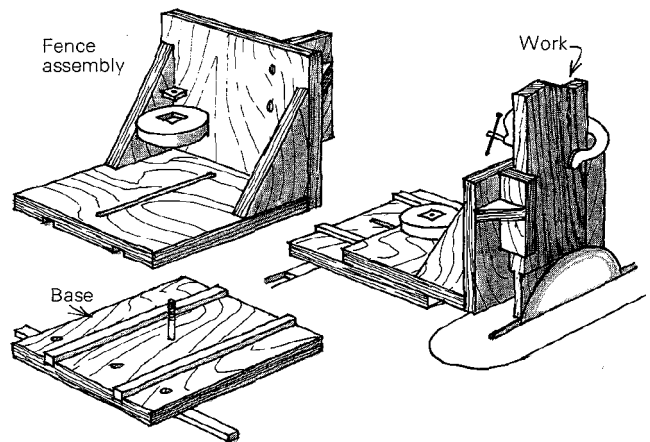

Folding cutting table

Here is a simple, useful rack for supporting large plywood panels when cutting with a hand-held power saw. It also doubles as a gluing table and, with a sheet of plywood on top, as a spacious worktable. When you are not using it you can fold it, scissor-like, into a compact unit for storage in a corner of the shop.

Material consists of 24 ft. of 2x2 construction-grade fir, eight carriage bolts ($\frac{1}{4}$ in. x $2\frac{1}{2}$ in.) and four lag screws ($\frac{1}{4}$ in. x 3 in.). Cut the fir into two long strips (72 in.) and four cross-beams (36 in.). Bolt the cross-beams to the long strips on 20-in. centers and 6 in. from each end. Countersink the carriage bolts a full $\frac{3}{4}$ in. into the cross-beams to clear the saw-

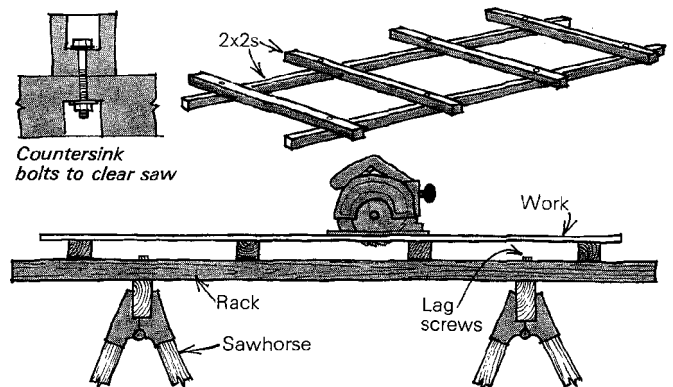

Methods of Work buys readers' tips, jigs and tricks. Send details, sketches (we'll redraw them) and photos to Methods, Fine Woodworking, Box 355, Newtown, Conn. 06470.

blade. Fasten the rack to two wooden sawhorses with the four lag screws centered 12 in. from each end of the long strips.

—Stephen Wysocki, Colton, Calif.

Routed drawer pull

Here's a simple and versatile drawer or door pull made with a modified router bit. Start with a small rabbeting bit (I used Stanley 82 150, which rabbets $\frac{1}{4}$ in. wide and $\frac{7}{16}$ in. deep). Grind off the pilot and round the corners, taking care not to lose the correct bevel. Chuck the bit in the router with the cutter about $\frac{3}{16}$ in. below the base.

Next drill or rout a template hole in the drawer front. I use a $1\frac{3}{4}$ -in. multi-spur bit, boring to a depth of only $\frac{1}{4}$ in. so the bit's pilot hole will later be removed. A flat-bottomed Forstner bit would be better because it leaves no pilot hole. If you use a straight router bit, you can cut any shape template hole.

Now plunge the router with the modified bit into the center of the template hole and work it out to the edge, using the bit's shank to guide (apply paraffin) against the side of the template hole. Finish the pull by rounding the top with a reverse-curve spoon gouge.—Miles Karpilow, Emeryville, Calif.

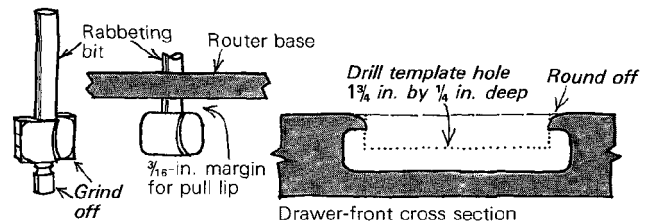

Portable-saw guide

Surely I am not the only small-shop woodworker who has spent an inordinate amount of time trying to cut up large sheets of plywood or trim the ends off long, heavy boards on a table saw. I have been happy with my small table saw, but I'm delighted to find my portable circular saw will do equally precise work on unwieldy pieces with the help of a guide that takes just minutes to make. The beauty of the guide is that it positions the blade right on the cut-line in one step.

The main components of the guide are a $\frac{3}{4}$ -in. wood straightedge nailed to a thin base of $\frac{1}{4}$ -in. plywood or Masonite. The saw rides on the base and is pressed against the straightedge. A long guide for cutting large sheets of plywood is best held with two C-clamps—one at each end. Be sure to make the straightedge wide enough so that the saw's motor housing will clear the C-clamps. After nailing the straightedge to a base piece slightly wider than needed, just

run the saw (with the blade you intend to use) along the base to trim off the excess. The guide is now ready to use.

A shorter variation of the guide is useful for cutting off long boards. Nail a strip of wood to the bottom of the short guide at right angles to the straightedge. Sandpaper glued to the underside will keep the guide from slipping when held at the far end with one C-clamp.

The short guide can also be used for cutting dadoes with a router. Just rout a slot into the base of the guide, carefully pressing the router base against the straightedge. Start the router cut over the right-angle strip on the bottom (remember to remove a bit of the sandpaper first). It's easy to clamp the guide at the right position on the workpiece by eyeballing the layout lines for the dado through the slot in the base.

—Rich Baldinger, Schenectady, N. Y.

Long-lived sanding strips

Narrow strips of sandpaper used to sand turnings or curved objects tend to tear, cutting less efficiently the shorter they get, until they are so many useless pieces of expensive paper.

To make them last longer, back them with fiberglass strapping tape; they'll be virtually untearable.

—J.S. Gerhsey, Lake Ariel, Pa.

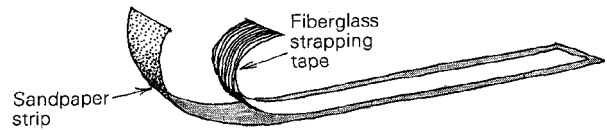
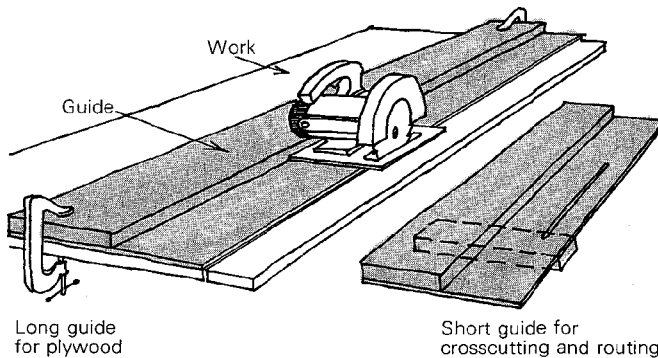

Roller support for ripping

Here's an inexpensive, adjustable roller support for long stock as it leaves the table saw or jointer. The support is made from an old rolling pin and a sturdy frame. The hand grips of the rolling pin are each supported by notched blocks which are adjustable for height by means of a bolt and wing nut.

—Rogier De Weever, Kelowna, B.C., Canada

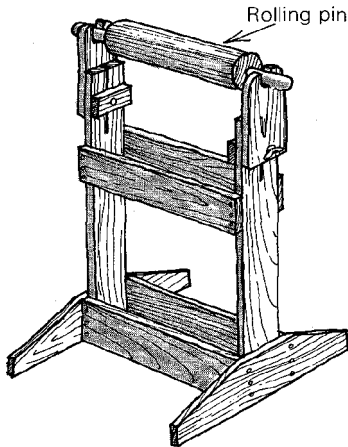

And another supporting idea

The key to an efficient table saw ripping support or panel crosscut support is a smooth-working, friction-free roller. I've found nothing that fills this requirement better or cheaper than ball-bearing furniture casters.

Fasten several of the casters in a close-spaced pattern on top of a homemade, adjustable stand. Or, for an instant support, fasten eight or ten casters to the end of a 2-ft. long 2x12. Then clamp the 2x12 in a Workmate vise at the right height. Since the casters roll easily in any direction just put the support where it's needed. There's no need to fuss with the orientation of the support as there is with other types.

—Larry Joseph, Alva, Okla.

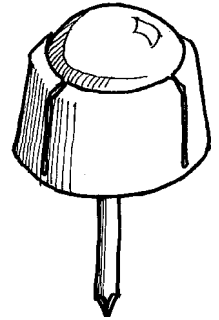

Non-skid finger pressure boards

A small board cut 45° across the grain and kerfed to form fingers is quite useful for holding work against the fence in shaping and ripping operations. But the fingers jam unless you shim the board off the table. Also, the board tends to move under the clamps and lose tension. I solved both these problems by ironing on twill, iron-on patches sold for repairing work clothes.

—R. P. Sykes, Thousand Oaks, Calif.

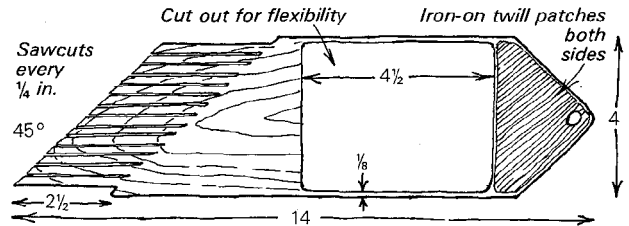

Methods of Work

Table-saw sliding crosscut fixture

Crosscutting wide panels using the table saw's miter gauge is awkward at best. Faced with a project requiring accurate crosscuts on 2-ft. wide, 6-ft. long panels, I investigated commercial sliding-table crosscut setups. Finding these too expensive for the flexibility and accuracy delivered, I designed and built an inexpensive all-wood sliding crosscut fixture. It's quite accurate and, depending on how it's mounted, has the capacity to crosscut pieces over 4 ft. wide.

The fixture consists of three parts: a sliding table, a guide bed and a support stand. For stability, I selected mahogany for the solid-wood pieces and $\frac{3}{4}$ -in., 14-ply aircraft plywood for the table and guide bed; any good-quality hardwood and hardwood plywood could be substituted. You'll need a 4x4 sheet of plywood and several 4-ft. lengths of hardwood in various dimensions for the sliding table and guide bed. Make the support stand from pine or whatever is available.

The guide bed attaches to the left side of the table saw (in place of the left extension wing) using existing mounting holes and hardware. The mounting bracket for the bed also doubles as a retainer hook to keep the sliding table from tipping with long, heavy pieces. A guide rail on the bed keeps the sliding table parallel to the sawblade.

The sliding table is a plywood panel with two strips on its bottom to form a channel for the guide rail. One of the channel strips doubles as a lip to fit under the bed's retainer hook.

The support stand is an *H*-frame dimensioned to support the bed. I used mortise-and-tenon construction. Furniture levelers in the top give needed adjustment capability.

To construct the fixture, first rip the bed, table and retainer hook strips from the plywood. Glue up the retainer

hook and glue and screw it in a dado cut in the bed. Cut a groove in the support beam and install it on the left edge of the bed with glue and screws. Cut the guide rail to size but save the installation for later.

Next, cut a dado in the bottom of the sliding table and mount the left-hand channel strip in the dado, screwing from the bottom without glue so the strip can be replaced when worn. Now, to set the channel gap accurately, place the guide rail temporarily against the left-hand channel strip and glue the right-hand channel strip in place on the table bottom.

Complete the support stand, mount the bed to the saw and

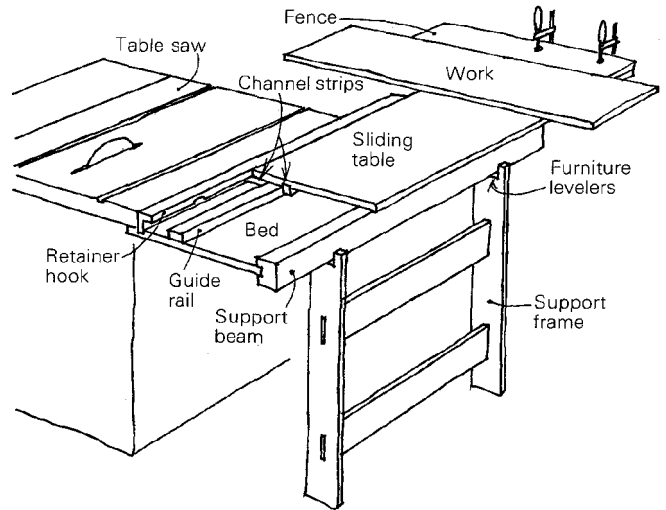

level it, using the furniture levelers between the stand and the support beam. Set the sliding table in place and shim out $\frac{1}{16}$ in. or so from the retainer hook. Now slide the guide rail into its channel and carefully fasten in place with screws through the bottom of the bed. To complete the fixture, paraffin all contact surfaces to cut down friction.

You can mount a permanent fence to the sliding table top. (Be sure to shim it off the table slightly so it won't catch on the front of the saw table.) I've found it convenient, however, to use temporary fences clamped to the sliding table. The gap between the bed and table leaves plenty of room for C-clamps or sliding clampette heads. To square a temporary fence, push a scrap of wood of the right thickness into the miter-gauge channel and use a framing square.

I mounted the fixture so that the back of the base lines up with the back of my saw. Although this gives maximum capacity, it is slightly inconvenient because the fixture projects about a foot in front of the saw. Others may want to consider shortening the fixture (thus lessening capacity) or mounting differently to minimize inconvenience.

—Roger Deatherage, Houston, Tex.

Protecting sawblades

Plastic backbone strips (sold by office-supply stores for binding reports) make inexpensive but effective sawblade guards. Cut a strip to length with a razor blade. If a longer strip is needed, epoxy two strips together using a short portion of the strip for reinforcement at the joint. The backbone grips the blade and will not fall off easily; to remove the strip, just slide it forward.

—B.A. Cartwright, Milwaukee, Wis.

Bowl-turningdepthgauge

When turning a hollow, as for a bowl, it is difficult to estimate how deep a cut has been taken. Although the best curves may be made by eye, it is necessary to know the depth to check on the remaining thickness of wood and avoid turning through. A ruler can be held against a straightedge across the rim of the bowl, but that is an improvisation. The tool described here is a more efficient way to check depth.

Make the stock wide enough to span the largest-diameter bowl your lathe can turn. The base must be flat. The other

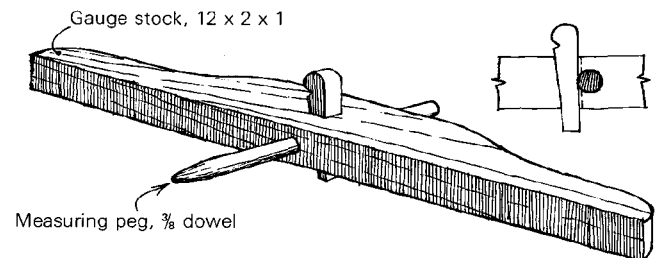

parts can be shaped as you wish, but edges should be rounded for a comfortable grip. It is easier to get the peg hole perpendicular to the base before other shaping is done. The wedge hole can be cut at the same time.

The peg may be a length of dowel rod. Its working end should be slightly tapered and finished with a little doming where it will touch the bowl.

The slot for the wedge has to be made with its edge cutting through the peg hole by a small amount, so pushing the wedge in tightens it against the peg. An overlap of $\frac{1}{32}$ in. should be enough. Make the wedge and measure the thickness of the stock centrally on it. From the distance across the

Methods of Work (continued)

wedge at these points, mark the width of the hole at each side. The ends of the wedge can be rounded and decorated, but a plain wedge works just as well.

—Percy W. Blandford, Stratford-on-Avon, England

Cutoff box

This easy-to-build box is superior to the miter gauge for simple 90° cutoff work on the table saw. Right-angle accuracy is built into the fixture; there's no adjustment necessary. Also, because the work is supported on both sides of the cut, there is none of the creeping that plagues cutoff work with the miter gauge.

Although the size of the fixture is discretionary, I suggest you make it just a little smaller than the table-saw top. For a typical saw this will give you room to handle work that's 18 in. to 24 in. wide. Make the bed from $\frac{3}{8}$ -in. plywood and the fences from 2x4s. Glue and screw the fences to the bed

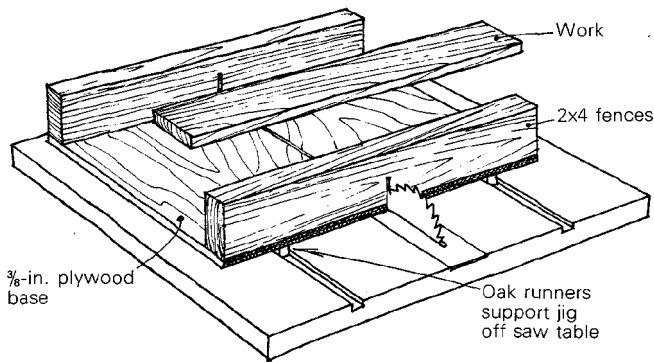

(avoid putting a screw in the path of the blade). Cut the oak runners so that they slide easily in the miter gauge tracks and support the bed about $\frac{1}{4}$ in. off the table. Be very accurate in attaching the runners and you'll always get a square cut.

—Jon Gullett, Washington, Ill.

Improved miter fixture

C.H. Dimmick's miter fixture for the radial arm saw ("Methods of Work," May '79) is very useful as described. But by leaving a 4-in. gap between the fence and the 45° guides, boards can be cut to length, then shifted to the 45° guides for mitering. Without the gap, the boards can be cut to length only by using another saw or by removing the jig.

—M.B. Williams, Potomac, Md.

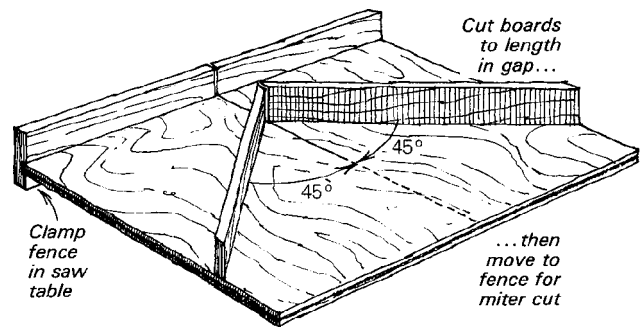

Go/no-go turning gauges

When turning spindles, finials and other pieces having several diameters, it is frustrating to have to reset a caliper to

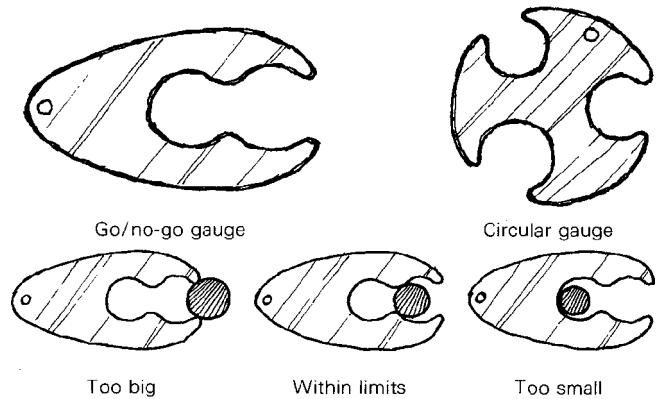

each of the different dimensions—especially when multiple parts are required. The metalworking industry uses "snap gauges" or "go/no-go" gauges to solve similar problems.

A snap gauge is one whose points are fixed at a given dimension. In precision metalworking, tolerances often thousandths of an inch are not uncommon. In woodturning the dimensions are not that critical, and a gauge can be readily made to within $\frac{1}{64}$ in.

More commonly, a snap gauge is made with two pairs of points and is called a go/no-go gauge (also a limit gauge or snap-limit gauge). Each pair of points is fixed at different dimensions. The difference between the two dimensions is the tolerance of the dimensions of the workpiece. This is especially handy when turning tenons or dowels.

If you have a good eye for turning and prefer a single set of points (as normally used with a standard outside caliper), several gauge variations are possible. A circular gauge, for instance, can be made to include all dimensions (three in the example shown) for a given turning. Or, a whole set of gauges with, say, $\frac{1}{16}$ -in. increments can be made.

Infrequently used gauges can be made of $\frac{1}{8}$ -in. tempered Masonite, but Masonite will wear rapidly if used while the work is turning. For a permanent, accurate gauge (with a touch of elegance) make the gauge from $\frac{1}{16}$ -in. or thicker hard sheet brass. Mark the size on each set of points and see what a difference a gauge makes. (See also John Rodd's gauges, pp. 74-75.)
—John R. Beck, DeKalb, Ill.

Turning long tapers

Here is an easy way to turn long tapers on the lathe. First, turn the workpiece to a smooth cylinder and mark the length of the taper. With a parting tool, cut the larger diameter on one end and the smaller diameter on the other. Set your outside calipers to the larger diameter and scribe a mark on the caliper knob (so you can count the knob's rotations later). Move the caliper to the smaller end and count the knob rotations as you close the caliper to the smaller diameter.

Suppose, for this case, you counted $5\frac{1}{2}$ rotations. Divide the length of the workpiece into $5\frac{1}{2}$ parts, mark each division with a pencil and return the caliper to the diameter of the larger end. Turn the caliper knob one rotation. This will be the correct diameter at the first line. Use the parting tool to

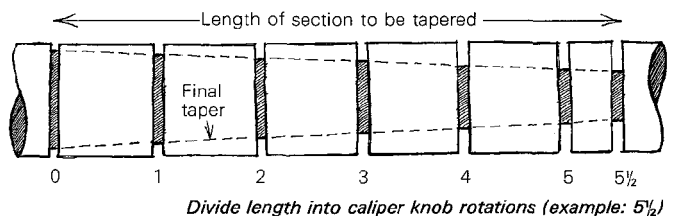

turn the workpiece down to that caliper setting at the first line. Then turn the caliper knob one more rotation and repeat at the second line. Continue the process across the workpiece. Complete the taper with a gouge or skew, using the parting tool cuts as a guide.

For a long, flat taper it might be necessary to base the divisions of the tapered length on half or even quarter-rotations of the caliper knob. This will keep the divisions closer together and facilitate the job of cutting the taper between grooves.
—Frederick C. Weisser, Houston, Tex.

Two table-saw miter jigs

This table-saw jig, below, has helped me to cut accurate miters for 25 years. To make it cut two table-length rails from well-seasoned oak or hickory and sand to a sliding fit in the miter-gauge channels. With the rails in place in the channels, set the 1/2-in. plywood base (cut a little smaller than the saw table) on the rails so that the midpoint of the forward edge is aligned with the sawblade. Fasten the base to the rails with

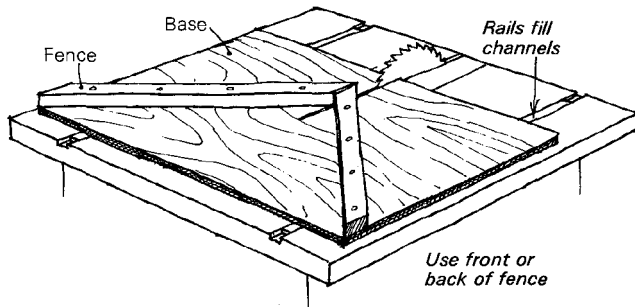

3/4-in. flathead screws. Now slide the jig back, raise the sawblade and saw into the jig 3 in. or so. From the center of the kerf, extend the saw-line to the back side of the jig. Mark two lines 45° from the saw-line with a draftsman's triangle and fasten the two 1-in. wide fences on the lines with screws.

Ordinarily, I use the front edges of the fences to hold the pieces to be cut. But to cut, say, the four pieces for a picture frame, cut the pieces square to length plus twice the thickness of the saw kerf and use the back edges of the jig fences. One fence aligns the work, the other serves as a stop.
—Bayard M. Cole, Marietta, Ga.

I use a table-saw miter jig that includes a holding block in a channel, shown below, to press the work against the fence. Be sure to cut the holding block large enough to secure the

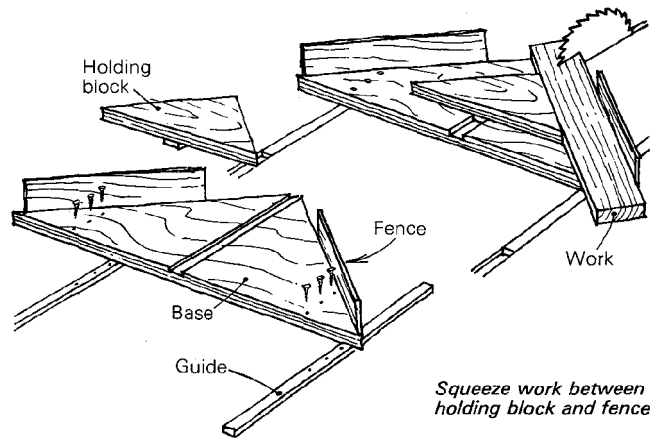

stock against the fence and to keep your fingers away from the blade.

—John C. Ort, Portsmouth, R.I.

Hose-clamp lathe chuck

This lathe chuck uses an inexpensive worm-gear radiator-hose clamp to tighten the collar around the work. Four saw kerfs provide the flexibility needed for loosening and tightening the chuck.

—Ernest Moyer, Royersford, Pa.

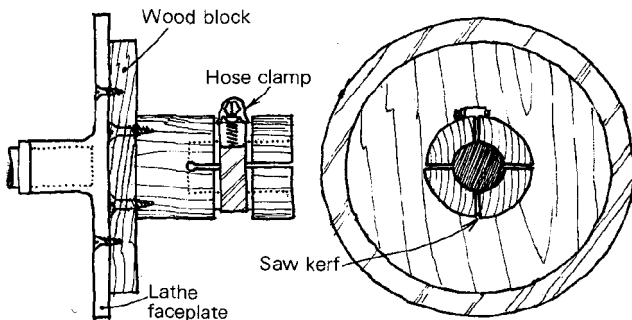

Jointing circular-saw blades

For a circular saw to cut with all of its teeth, it must first be jointed and thereafter mounted the same way every time.

To joint, mount the blade with the trademark up. Then tighten so that all the slack between the arbor and the saw-hole stays opposite the trademark at top. It is a good idea to mark the arbor too, so you can also keep it always in the same position when mounting. With the saw running, slowly raise the blade into a grindstone lying flat on the table surface. When you've gotten a shine on all teeth, carefully sharpen

each tooth (file or grind) until the shine disappears. When you return the blade to the machine, always mount it with the trademark up. The blade mounted in any other way will run in an orbital pattern; only a few teeth will cut.

I always joint and file even new blades—they need it as much as used blades.

—Norman Brooks, Greenville, Pa.

Are you taking notes?

A small 3x5 pad of paper anchored to the wrist with a large rubber band is invaluable when taking measurements, sketching details or working in cramped quarters. The arrangement leaves both hands free for work yet provides an instantly available writing surface that never gets misplaced.

—James Vickery, Garrison, N. Y.

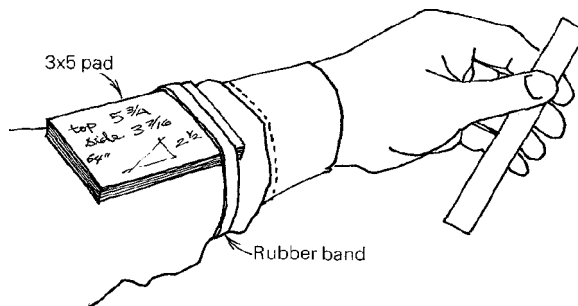

Methods of Work buys readers' tips, jigs and tricks. Send details, sketches (we'll redraw them) and photos to Methods, Fine Woodworking, Box 355, Newtown, Conn. 06470.

Methods of Work

Finger-joint jig

Here is a box or finger-joint jig like Tage Frid's (*Fine Woodworking*, Winter '76), except that it uses the table-saw rip fence rather than the miter gauge—a sturdier, easier-to-adjust arrangement. It consists of a guide rail bolted to the saw's rip fence, and a sliding-fence assembly that holds the work. Make the guide rail from particle board or hardwood plywood and cover both sides with plastic laminate to reduce sliding friction. Bolt the rail to the rip fence with four $\frac{1}{4}$ -in. bolts. Countersink the bolt heads on the inboard side.

As with the rail, the sliding-fence assembly is made from particle board or plywood with plastic laminate glued to the bearing surfaces. An essential part of the jig is the hardwood tongue installed in the rail that slides in a groove in the fence assembly. Tack nylon furniture glides to the bottom of the fence assembly to allow the jig to ride freely along the table.

Set-up time is fast—a good-fitting joint can usually be achieved in two test runs. The first step is to install a dado blade for the desired finger size, say $\frac{3}{8}$ in. Raise the dado blade about $\frac{1}{32}$ in. above the thickness of the stock to be cut. Now screw a scrap of $\frac{3}{4}$ -in. material to the front of the sliding fence assembly to serve as a disposable fence. Drill a $\frac{3}{8}$ -in. hole in the center of the scrap fence about $\frac{1}{2}$ in. from the saw table. Insert a short $\frac{3}{8}$ -in. dowel in the hole to act as a guide pin. Now adjust the rip fence/rail so that the distance between the guide pin and the dado blade is equal to the size of the dado— $\frac{3}{8}$ in. in our example.

Using a piece of scrap, start a test pass. While holding the stock vertically against the fence assembly and against the guide pin, pass the stock over the dado blade. After each cut, shift the stock to the right so that the previous cut registers

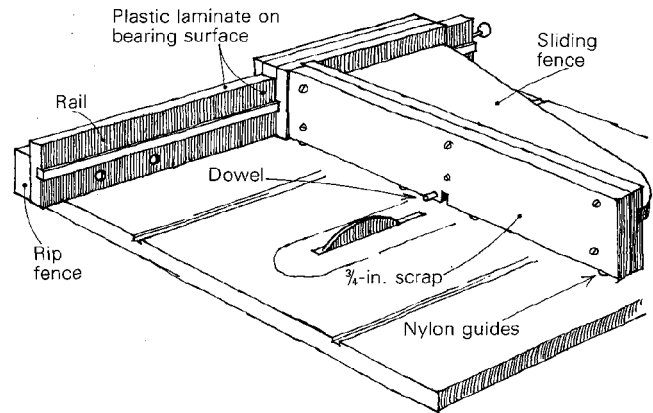

over the guide pin. Start the cut in the second test piece by lining it up with the sawcut in the fence (rather than the guide pin). The joint should be snug but loose enough to allow gluing. If the joint is too tight, move the rip fence to the left. If it's too loose, move the fence to the right.

—Tom Burwell, St. Paul, Minn.

Cheap stain

At the picture-frame manufacturing company where I work, 12-ft. bundles of frame molding are dumped into a vat of stain and then put aside to dry. I noticed that much stain was lost as it dripped off the drying bundles and asked the owner why he let the stain drip away without any attempt to collect and reuse it. His answer was that the "stain" was actually lap cement (an asphalt-based roofing product available at build-

ing-supply stores) diluted with turpentine, so inexpensive he didn't bother to reclaim it.

Our shop mixture of 5 gal. lap cement to 50 gal. turpentine produces a medium walnut color. At home I find a half cup of cement to a half gallon of turpentine will stain pine a deep golden brown. —George Kramer, Santa Rosa, Calif.

Masking out squeeze-out

Glue squeeze-out problems can be avoided by covering areas near joints with masking tape. Carefully place the tape during final assembly so that it covers the area but doesn't get caught in the joint. This technique is especially useful on the inside corners of joints (drawers, boxes, etc.) where cleanup is a problem. —Tim Rodeghier, Highland, Ind.

Laminated bowls

The method I use to make six-sided bowls creates boldly repeating patterns and reduces layout and blank-assembly time. I start by laminating a wedge-shaped beam with 60° sides, sandwiching veneer of various thicknesses between four 3/4-in. hardwood boards. The widest part of the wedge (which I make of a highly figured wood) will be the outermost part of the bowl, and 5 in. here will produce a 10-in. diameter bowl. The length of the wedge will determine the bowl's height.

I set the jointer fence at 30° and joint off two sides of a scrap 2x4, leaving a chunk of wood angled 60° on each edge. Then I cut off six thin wafers, arrange them in a circle and check for proper fit. If there are gaps, I adjust the angle of the jointer fence and try again. When the angle is correct, I joint both sides of the laminated beam deep enough to clean out depressions and glue. Then I cut the beam into six equal sections and dry-fit.

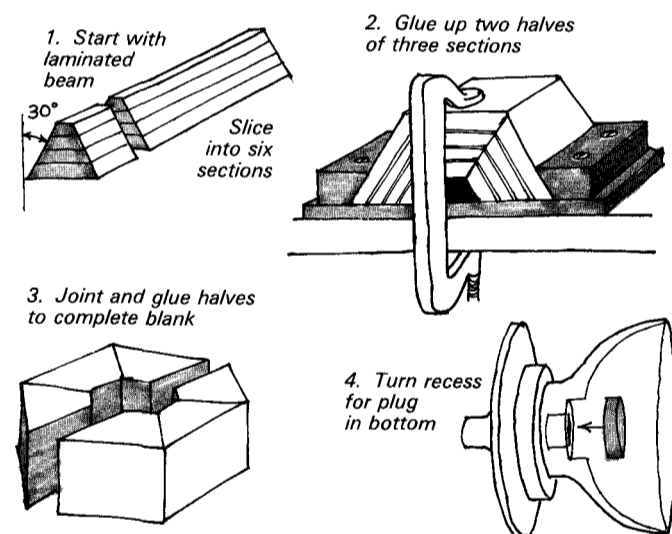

Now glue up two bowl-blank halves of three sides each. Use a clamping jig. Next, dry-fit the two halves and, if they don't fit perfectly, run the faces of the two sections over the jointer. Glue the two halves together to complete the blank. When you turn the blank, simply make a recess for a round plug to fill the hole in what will be the bottom of the bowl.

—Roy Ashe, Luther, Mich.

Faceplate taping revisited

Dennis Castagna's procedure for taping bowls on a faceplate ("Methods of Work," May '79) prompts me to suggest a similar method using double-faced tape.

First, sand and clean the back of the work to ensure good contact. Then apply a layer of double-faced tape to the face-

plate without overlap. Attach the work to the faceplate by squeezing momentarily in a vise. For larger workpieces use two layers for more holding power.

Remove the work by wedging a chisel between the faceplate and the workpiece.

—Max Kline, Saluda, N.C.

EDITOR'S NOTE: Standard hardware-store "carpet tape" may be adequate only for smaller projects. Kline recommends a special tape manufactured by Nashua Corp., Nashua, N.H., which, because the adhesive is partially cured, softens less during the heat of sanding.

Another proponent of double-faced tape, Russ Zimmerman (RFD 3 Box 57A, Putney, Vt. 05346), recommends Permacel—a thicker, cloth-backed tape with more holding power. Zimmerman will sell and ship the cloth-backed tape for \$7.50 a 75-ft. roll.

Zimmerman states that "most people start using this tape cautiously, but confidence builds." He now uses the tape for 15-in. wide, 4-in. thick bowls.

Bench dogs: round versus square

While building a European-style workbench, I experimented with both square and round bench dogs. I concluded that round dogs (wooden or steel) are superior in several important ways. First, it is much easier to put a round hole into a bench top (or anything else). Second, the round dogs are easily made in a variety of shapes that will rotate in the hole to conform to the shape of the work. Square steel dogs cannot rotate, more easily mar the work, and can drop through the hole in the bench top.

Round dogs can be turned on the lathe or built up from 3/4-in. doweling by gluing hardwood shapes to the tops of the

Bench dogs can be...

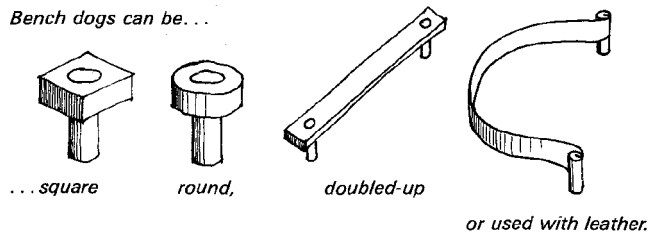

or used with leather.

dowels. A wide variety of shapes, padded or in combinations, can be used as the work requires.

If I had a bench with square dogs, I would convert it to use round dogs by filling the square holes with wood of the same density as the top and redrilling new round holes.

—William E. Eetzner, St. Petersburg, Fla.

Recycling tool handles

One way I beat inflation is by making my own tool handles from old mop, broom and shovel handles, usually made of ash, hickory or beech, that the average homeowner pitches in the garbage.

Here's how I make octagonal handles for new carving-tool blades (which I buy unhandled). First, clamp a beech mopstick in the vise, leaving about 6 or 8 in. protruding diagonally at the top. Mark the handle length and taper the sides from this line to the ferrule end with a drawknife. Take shallow cuts at first, turning the stick frequently for uniformity.

For the ferrule, use the metal end of a spent 20-ga. shotgun shell. If you're not a hunter, look for empty shells at a skeet shooting area. To separate the ferrule from the shell, drill through the center bottom (where the shotgun hammer hits the shell) with a 1/4-in. bit. This releases the hull and inner packing, which can then be pulled out with pliers. The hole that's left is usually the right size to receive the carving tool's tang. To mount the ferrule, mark its length on the handle,

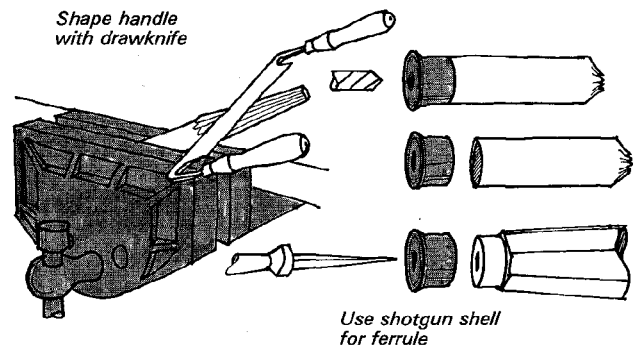

and with a second-cut wood file, remove enough wood to seat the ferrule snugly.

Beech works well for carving-tool handles, but other woods are more suited to striking-tool handles. Old shovel handles (usually hickory) are best for replacement hammer handles; I work them down also with a drawknife. Broken ash baseball bats (check the local high school's practice field) are excellent for hammer, hatchet and lathe-tool handles. I finish all these handles with a couple of coats of tung or linseed oil.

—Rob Russell, Joliet, Ill.

Another no-cost picture-frame clamp

My modification of Duane Waskow's picture-frame clamp (November '78) uses a tourniquet to apply pressure at the glue joints. To make the clamp, cut four L-shaped clamping blocks from $\frac{3}{4}$ -in. pine and groove the outside edges of the blocks a little wider than the rope diameter. Then round, smooth and wax the grooves to minimize friction. Cut or drill a circular area at the inside corner of the blocks to allow for slight inaccuracies (which accumulate at that point) and to permit excess glue to escape. When you're ready to glue, place a piece of waxed paper under each block to prevent it from becoming glued to the frame.

For the rope, choose something with a little stretch—I use $\frac{1}{8}$ -in. nylon. Tie a loop in the rope just long enough so that it can barely be snapped over the blocks. This will hold the frame together while final adjustments are made in the glue joints. When the joints are right, twist a dowel onto the rope and turn it to produce whatever pressure is desired. The leverage is tremendous so don't overdo it. It's a good idea to put a weight on the frame while you're applying pressure. If one corner comes up a little, the whole assembly may twist and fly apart.

When the pressure is sufficient, tape or tie the dowel to the rope. Always maintain a tight grip on the dowel—it can unwind with surprising force.

—H.N. Capen, Granada Hills, Calif.

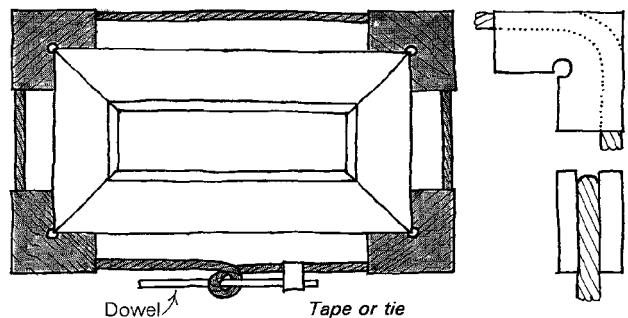

Wooden pull/catch

This cabinet door pull serves a double function—it's also a locking catch. The material cost is negligible but you'll spend about an hour making and installing the pull. The catch is designed for doors hung flush with the framing, so a separate door-stop must be incorporated.

First, square a line from the edge of the cabinet door at the position you want the pull. Bore a $\frac{3}{8}$ -in. hole through the cabinet door 1 in. from the door's edge and centered on the line. Then cut a 1-in. deep, $\frac{1}{4}$ -in. wide mortise into the door edge. Start the mortise $\frac{1}{8}$ in. below the position line and stop the mortise 1 in. above the line. Cut a corresponding $\frac{3}{8}$ -in. deep mortise in the frame.

After the mortises are completed, lathe-turn the pull handle with a knob on the front and a round tenon on the back. The tenon should slip-fit in the $\frac{3}{8}$ -in. hole and be as long as the door is thick. Dry-fit the pull in the hole and, while holding the knob at the locked position, reach through

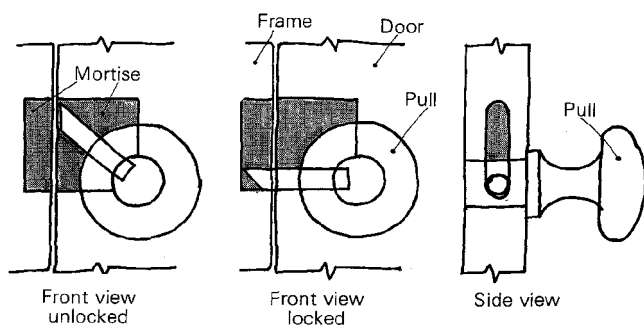

the mortise and drill a $\frac{1}{4}$ -in. hole in the tenon to receive the latch/dowel.

To complete the pull/catch, coat the tenon with beeswax, put a drop of glue in the latch-dowel hole and set the pull in place. Insert the latch-dowel through the mortise into the hole. Then, with the handle turned to the unlock position, cut the latch-dowel flush with the door edge.

—Michael Lynch, San Francisco, Calif.

Socket reamers

Here are two spur-of-the-moment, large-diameter reamers that work well for tapering candlestick sockets and the like. Since a candlestick reamer won't be used often, practically any scrap of steel will do for the cutter on the "deluxe" version. Install the sharpened cutter in a saw kerf with a screw. Use two screws or pin the blade through the dowel body if the cutter shifts in use.

You don't need a lathe for the sandpaper version—it can be whittled and filed sufficiently round by hand. Install one end of a sandpaper strip in a slot in the head. Then wrap the

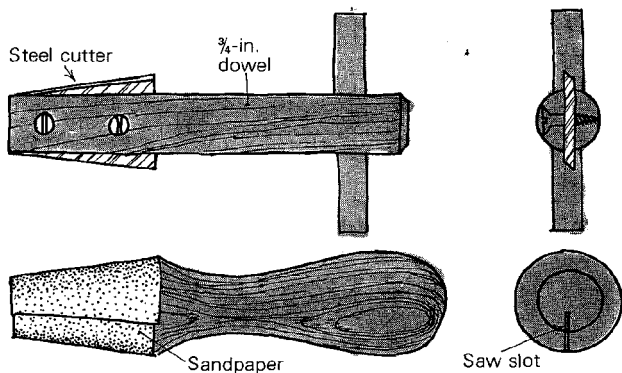

strip around the reamer; there's no need to fasten the other end of the strip.
—Van Caldwell, Cincinnati, Ohio

Electric-cord suspension arm

It is much easier to use portable electric tools if the cord can be suspended from above so it doesn't drag across your workbench. This cord suspension arm is designed to move easily to different heights or to different locations in the shop. The arm pivots on electrical conduit pipe, which is cheap and light but strong enough. The conduit slips into 1-in. screw-eyes spaced so that when the arm is raised, the lower pipe will disengage for removal.

—Pendelton Tompkins, San Mateo, Calif.

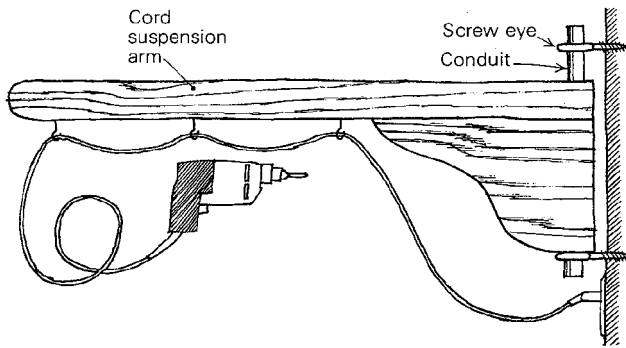

No-mess epoxy mixing

To mix small amounts of epoxy, simply squeeze equal amounts of resin and hardener into the corner of a plastic sandwich bag. Twist and mix the two until a uniform color

appears. Then puncture the bag with a pin and squeeze out the glue as required. No clean-up is required—just throw the bag away.
—Edgar E. Gardner, Nashua, N.H.

Sanding mop

To sand hard-to-get-at spots, make a sanding mop from a nut-and-bolt arbor and a handful of small pieces of sandpaper. Overlap the sandpaper like shingles around the arbor and chuck it in a drill. The irregular edge eliminates the hard sanding line produced by rubber-backed discs.

—Allan Adams, San Francisco, Calif.

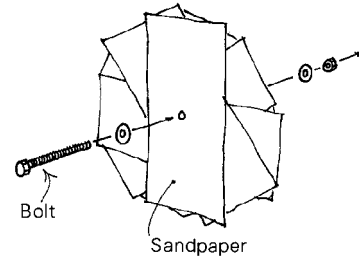

Spanish luthier's clamp

I know of no simpler, cheaper or more convenient method to clamp up edge joints than the Spanish luthier's technique for joining guitar tops and backs. Though intended for thin wood, the technique is easily adaptable to any thickness, width or length required. All that is needed are several long wedges, a few 1x2s (longer than the work is wide) and a length of 1/4-in. rope.

When the work is ready to be glued, lay it on the 1x2s as

shown. Tie the rope to the right-hand stick and weave it over the work and around both ends in a figure-eight. The diagram below shows one figure-eight loop for clarity but several are necessary. Moving to each 1x2 in turn, repeat weaving the figure-eights, tying off the rope on the last stick.

Now insert the wedges under the middle of the figure-eights and drive them home with a mallet. This will apply clamping pressure without danger of the wood buckling and damage to the edge. Wax the wedges and 1x2s to prevent their being glued to the work by squeeze-out. The whole process is fast, but it's advisable to practice a few times to get the hang of the rope weaving.

—Douglass Peoples, Arlington, Va.

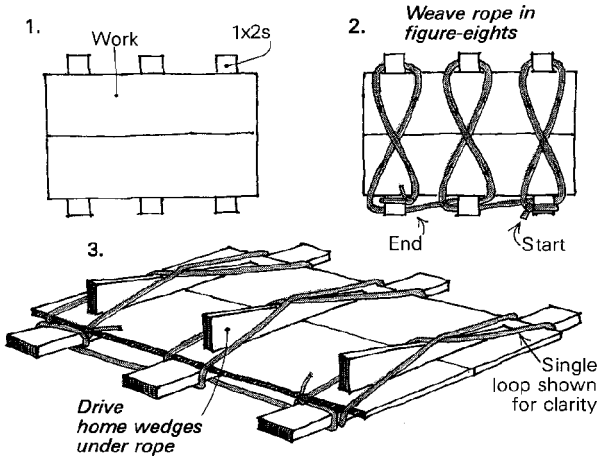

Sliding dovetail bookends

Most furniture designed to hold books doesn't. Shelves must be filled with books end to end or pairs of movable bookends must be used. I make integral, sliding bookends from the same wood as the bookshelf. Cut 1/2-in. dovetail keys across the bottoms of matched blocks. Then rout a mating dovetail slot in the shelf end to end. The fit of key to slot should be smooth but not loose. Allow for swelling during humid seasons. Slide the bookends into the slot prior to final assembly. Books placed between the bookends supply the necessary leverage to jam the key tight in the slot. Bookends can be easily repositioned if book tension is relaxed.

An alternate approach for open shelves is to stop the slot a few inches from each end. Widen the slot (with a straight router bit) in the middle of the shelf to insert the bookends.

—Rick Kramer, Beech Creek, Pa.

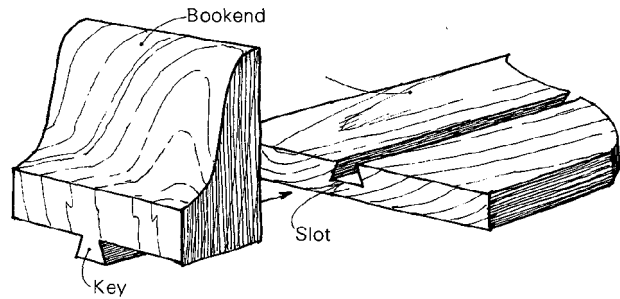

Methods of Work buys readers' tips, jigs and tricks. Send details, sketches (we'll redraw them) and photos to Methods, Fine Woodworking, Box 355, Newtown, Conn. 06470.

Methods of Work

Wooden bullet catch

This wooden bullet catch takes a little more time to make and install than its store-bought metal cousin. But the sound alone is worth the effort. The catch consists of a turned (or whittled) maple bullet, a small compression spring and a brass retainer pin. First turn the bullet with a retainers notch in its middle and a spring-sized finger on its tail. To complete the bullet, shape the head to a rounded point.

Next, drill a hole in the door edge just deep enough to accept the entire bullet under spring pressure. Pencil in the outline of the hole on the inside face of the door to aid in locating the retainers-pin hole. Hold the bullet on the outline of the hole (with the bullet tip protruding) and mark the retainers notch location. Drill the retainers-pin hole so that the pin fits in the notch and lets the bullet protrude just enough to catch in the jamb. The pin hole can be drilled from the inside, blind to the door's outside. But if the pin hole is drilled through to the face, the pin can be knocked out later to replace the bullet when worn.

To complete the catch, drill a dimple in the jamb to fit the bullet tip, or install a wooden striker plate in a shallow mortise. If desired, a striker plate and doorstop can be combined in one unit.

—Michael Lynch, San Francisco, Calif.

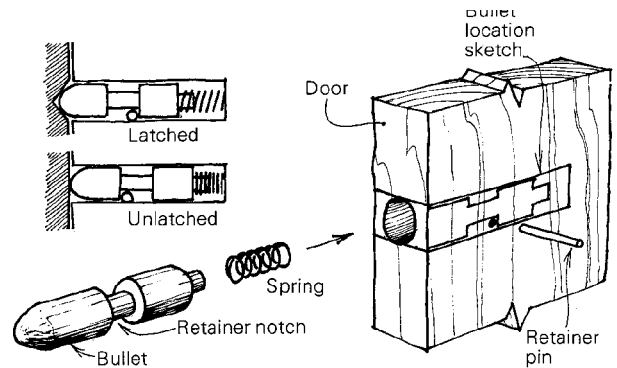

Wooden mallet

At least one wooden carpenter's mallet belongs in every woodworker's tool chest. The advantages of wood over steel are obvious—less damage to tools, work, thumbs and eyes. For the price of one steel hammer, you can make a dozen mallets, each tailored to a particular job.

The traditional mallet has a solid-wood head mortised through for the wedge-shaped handle. My laminated head design is just as strong and much easier to make. Begin by cutting the handle and two center laminations for the head from the same 1-in. thick board (this saves a lot of fitting later). Copy the handle's wedge angle (no more than 1/2 in. of taper) onto one of the side laminations. Then glue up the head block, carefully aligning the center laminations with the wedge-angle pencil lines. When the glue has cured, bandsaw

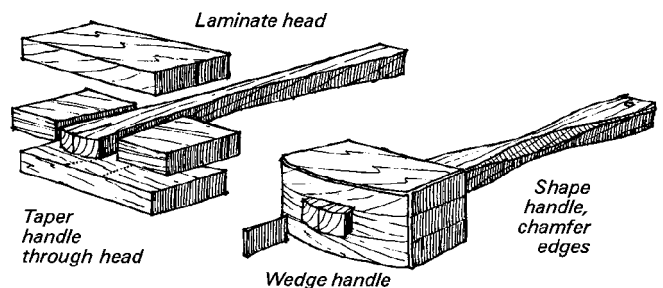

Methods of Work (continued)

the head to shape. Then chamfer all the edges to reduce the chances of splitting and insert the handle.

—Daniel Arnold, Viroqua, Wis.

Trimming dovetails

With through dovetails it's accepted procedure to cut the joints a bit long and trim the ends flush after gluing. The fastest method I've found for trimming the slight overhang is to use a router equipped with a carbide-tipped, ball-bearing flush-trim bit. Start the cut at the very corner to prevent the bit from grabbing at the beginning. Always feed against the direction of the cutter rotation. After routing, a light planing or sanding will complete the job.

—Don Herman, Brecksville, Ohio

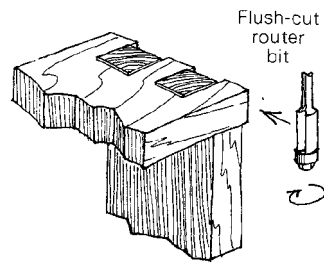

Purfling router guide

In stringed-instrument construction the router is commonly used to cut a small shoulder around the perimeter of the instrument. The dado holds an ornamental inlay (purfling) used to cover the glue seam between top and side. The chore requires a precise cut with a router guide capable of following sharp curves. Though I've tinkered with various adjustable guides, I keep coming back to simple, wooden, preset guides.

The guide consists of a wooden finger glued to a crescent-shaped piece of plywood, which ensures proper positioning. A single bolt and wing nut provide fast but secure fastening.

For inlay work I have three guides, each made to cut a rabbet width corresponding to one, two, or three layers of veneer. Thus, for any given thickness of inlay I just bolt on the right guide. No time is lost making practice cuts.

—George Mustoe, Bellingham, Wash.

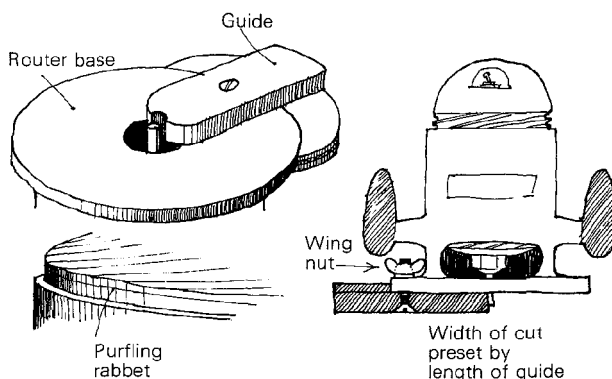

Lineshaft sharpening

This inexpensive sharpening setup puts a keen edge on tools in seconds without the usual heat build-up problems of powered abrasive wheels. To construct the setup, laminate four 7-in. wheel blanks from plywood or particle board. Epoxy the blanks to shaft collars, which are set-screwed to the 1/2-in. lineshaft. The shaft turns in pillow blocks mounted on an oak frame. If a lathe is not available, the wheel blanks can be trued right on the lineshaft with a chisel and a temporary tool rest.

Cement emery-cloth strips (80 grit and 320 grit) to two of the wheels, lining the wheels first with burlap-backed cork (from a linoleum dealer). Cement leather to the other two

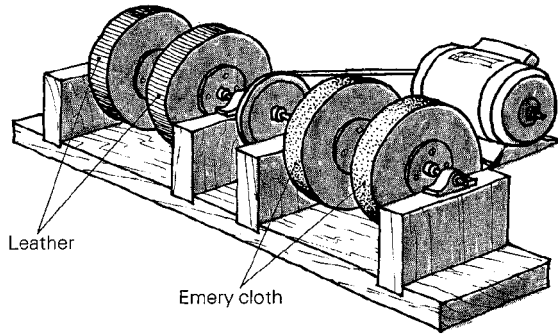

wheels. Mount the leather flesh side out to one wheel and hair side out to the other. Charge the "flesh" wheel with emery, the "hair" wheel with rouge. Using rubber cement for all mountings will make replacement easier later on.

An old 1/4-HP appliance motor will provide sufficient power. Size the motor and lineshaft pulleys so the wheels turn at 500 to 600 RPM up and away from the operator.

Dull tools may need treatment on all four wheels. But most tools can be sharpened on only the finer two or three wheels.

—Robert L. Koch, Tarsio, Mo.

Sharpening fixture

I have always had problems grinding points on tools with tapered shanks. With this simple fixture, it's easy.

To construct the fixture, drill a hole a little larger than the shank of the tool through a hardwood block. Then drill a 1-in. hole from the top, partway through. Glue a scrap of

rubber inner tube to the bottom of the block to keep it from slipping about.

To use, insert a finger in the top hole to apply slight pressure against the tool shank. Rotate the tool against the grinder or belt sander with the other hand.

—Jay Wallace, Ashland, Ore.

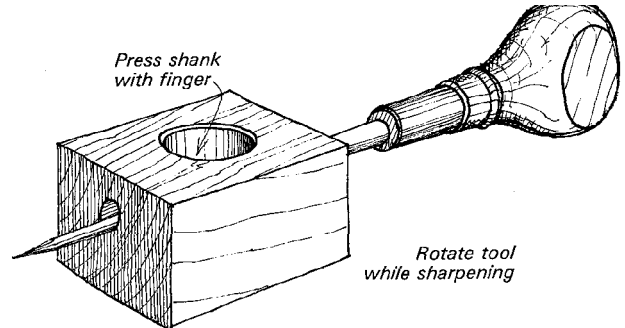

Making dowels

Although I often need oak or walnut dowels, they're not readily available where I live. Not owning a lathe, I resurrected an ancient but effective dowel-making method that uses a simple jig and hand plane. Dowels made this way are, in my opinion, superior to those made by driving blanks through a steel sizing plate.

Construct the dowel-holding jig by ripping several V-grooves in a 2x6. A variety of groove depths will allow a wide range of dowels sizes. Screw a stop on one end of the 2x6. Place a square dowel blank in a groove and plane the top corner. Turn and plane repeatedly until the blank is oc-

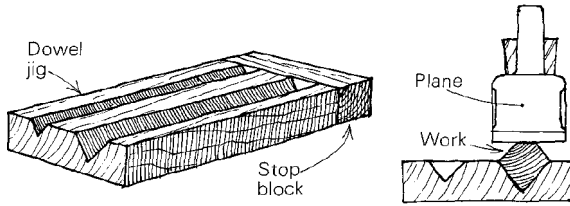

tagonal. Successive turn/plane cycles will result in a nearly round dowel, which can then be finished with sandpaper. One small drawback—the blanks must be flipped end for end as the grain direction changes.

—Frederick C. Wilbur, Shipman, Va.

Lathe sanding drum

This inexpensive but effective drum sander is made and used on the lathe. Center an 18-in. long 4x4 on the lathe and turn a cylinder of 3½-in. diameter. Carefully reduce the diameter of the cylinder until a standard sheet of emery paper wraps around the drum without gap or overlap. Glue the emery cloth (I used 100 grit) to the drum with hide glue. Wrap the entire surface with a sash cord and let dry overnight. Turn

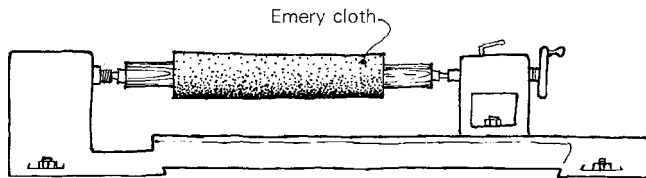

down the ends of the drum to about 1½ in. to give free working space. The size of the drum can be scaled up or down for different applications. A smaller open-end drum could easily be made using a screw center.

—Harland Smith, Waterloo, Iowa

Dovetail marking setup

This setup for scribing pin sockets in hand-dovetail construction eliminates hand-held slipping and repositioning problems. Put a spacer block under a handscrew on the workbench. Align the two workpieces, tighten the handscrew, then lock the whole in position with a C-clamp.

—Richard Kendrot, Windsor, N. Y.

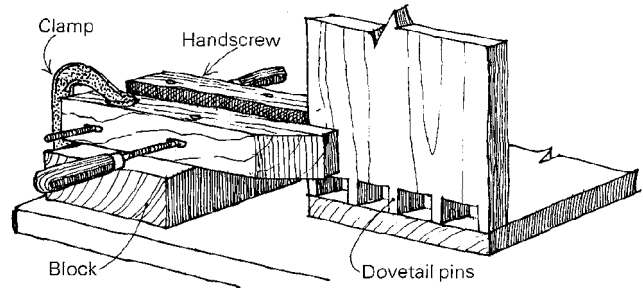

Wooden high-chair mechanism

This high-chair tray adjustment mechanism is simple, won't pinch, rust or jam and is sturdy enough to survive several rowdy babies.

Turn the high-chair arms in a series of rings and flats, then

Methods of Work (continued)

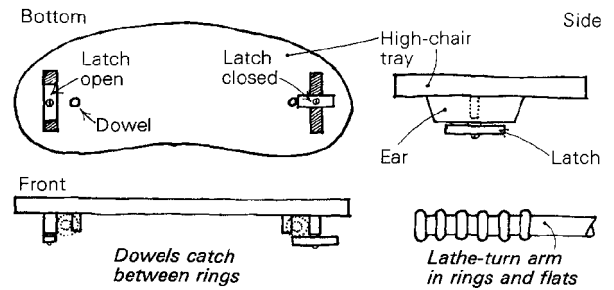

mount them on the chair level and parallel. Install two dowels on the underside of the tray to engage the inside of the arms. This gives the needed in-out adjustment. Two pivoting latch-dowels mounted on ears hold the tray down.

—J.B. Small, Newville, Pa.

Tape tricks for little sticks

I find myself making lots of little things—small boxes, wooden jewelry and the like. Until I discovered a couple of tricks using double-faced tape, I had a devil of a time sawing the little hunks of wood needed for this kind of work.

To make a straight cut on an odd-shaped, thin slice of wood, run a scrap board through the saw using the rip fence. Stick down a length of double-faced tape to the top of the scrap, peel off the protective paper and mount the odd-

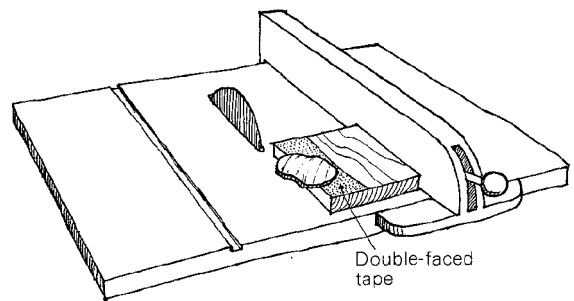

shaped slice on the tape for cutting. Don't rely totally on the tape's holding power—hold the piece down with a finger or stick while cutting.

Double-faced tape can also be used effectively in cutting thin strips from the edge of a board. Cut a scrap board with a built-in stop as shown and mount the tape along the inside

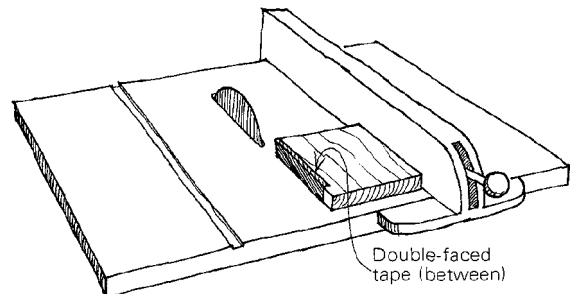

edge. The tape holds the slice away from the blade after it is cut. Use the same care in making the cut as if the tape were not there.

—H.N. Capen, Granada Hills, Calif.

Bandsawing duplicate parts

To bandsaw multiples of intricate wooden-toy parts, I stack several blanks together with double-sided tape between. The tape holds firm during bandsawing, drilling and edge-

sanding operations. Double-sided tape eliminates nail holes, replaces awkward clamps and reduces layout time (lines need be drawn only once). Pans are easily separated by inserting a chisel into the tape joint and tapping lightly.

—Larry D. Sawyer, Ridgecrest, Calif.

Light stands

For temporary lighting in my new shop, I built a couple of light stands from 2x4s with 1x4 legs. Two or three inexpensive clamp-lights completed the fixtures. The poles are easy to move around and don't take a lot of room. They're versatile and inexpensive. Although I've added overhead lighting now in my shop, I haven't been able to do without my light stands.

—A. Miller, Lakewood, Colo.

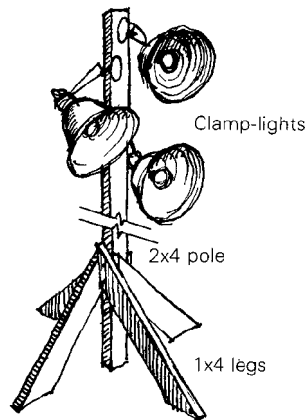

Horizontal boring jig

My boring jig, which uses a 1/2-in. portable drill, is similar to a conventional horizontal-boring machine except that the table moves rather than the drill. The jig consists of a base, a hinged drill platform and a sliding table.

Make the base and sliding table from 3/4-in. hardwood plywood. The drill platform should be extra stiff, so laminate two pieces of 1/2-in. plywood to give a 1-in. thick platform. Spindle elevation is adjusted by raising or lowering the hinged drill platform. Install a piano hinge on one edge and two or three bolts with wing nuts for adjustment on the other edge. If adjustment is needed over a wide range (say, 3 in.), some sort of pivoting arrangement would be required for the adjustment bolts.

Most 1/2-in. drills have a threaded handle socket on the top or side that will accept standard 3/4-in. threaded pipe. Secure the drill to the platform with a short piece of threaded pipe and a standard floor flange.

Elevating the platform swings the drill through a short arc, so the fence on the sliding table must be mounted through slotted bolt holes to allow for movement. Hardwood rails on the bottom of the table mated with hardwood guide blocks on the base provide the tracking action for the sliding table.

—Vanessa Skedzielewski, Sierra Madre, Calif.

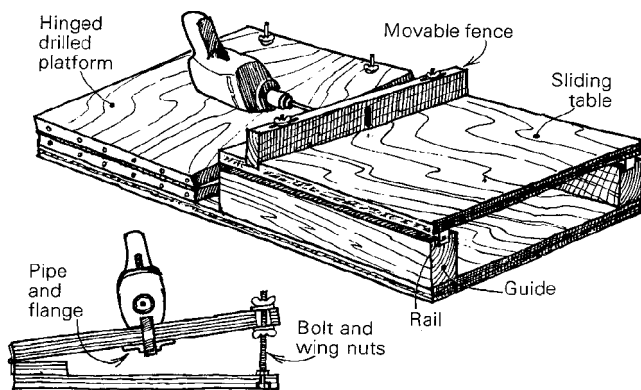

Methods of Work buys readers' tips, jigs and tricks. Send details, sketches (we'll redraw them) and photos to *Methods*, Fine Woodworking, Box 355, Newtown, Conn. 06470.

Methods of Work

Cutoff table

Back in the days before I had a radial arm saw in my shop, I worked out a cutoff table to use with my portable circular saw. The fixture consists of a 2x12 table, a 2x4 fence and a guide bridge. The rabbets on the two bridge pieces should face each other and be spaced just wide enough to fit the base of your portable circular saw. If desired, a stop block can be C-clamped to the fence for accurate duplicate cutoff work.

— C. G. Fader, Ketchikan, Alaska

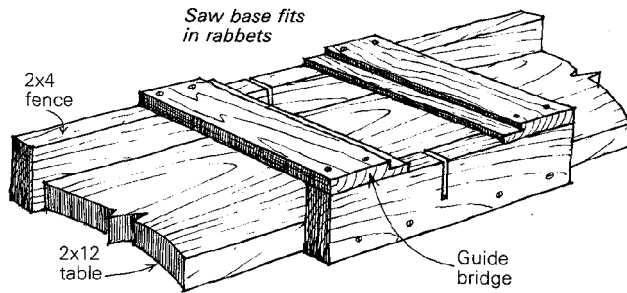

Mortising fixture

The sides of a cradle I built recently were made of slats mortised into the frame. The router-based mortising fixture I built for the project helped me cut all those little mortises quickly and easily. The fixture has three simple pieces: a hardwood clamping lip, a birch-plywood router base and a Masonite hold-down. Bolt the 2x3 clamping lip under the workbench flush with the front edge. To permit deeper mor-

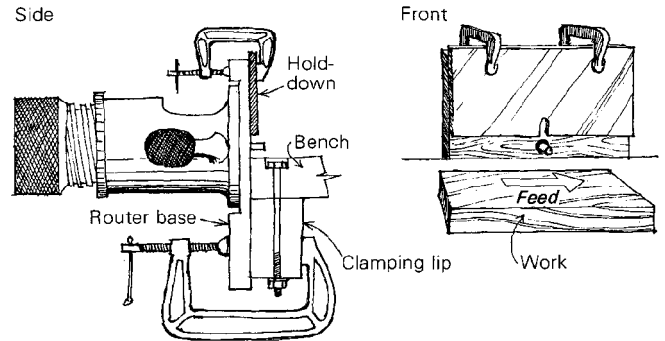

tises, rout a $\frac{3}{8}$ -in. recess in the plywood base to fit the router. Mount the router in this recess using countersunk screws driven from the face.

To use, clamp the base to the clamping lip, making sure the bit is the right height above the workbench. Then clamp the hold-down in place. Stand behind the router and, sighting from above, pull the workpiece into the router. A router cut or pencil lines on the hold-down are needed to show the left and right boundaries of the cut. Feed the work from right to left. The router produces mortises with rounded ends, which can be squared up with a chisel. But it's easier to round the tenons with a rasp or sandpaper.

—G. R. Livingston, New York, N.Y.

Cabinet-hanging prop

After years of struggling to hang upper cabinets, I built this simple prop. Now I can hang the upper units by myself, re-

ardless of their size. Make the prop from $\frac{3}{4}$ -in. plywood, except for the center support beam, which is oak. Dimensions depend on the height of the jack. For this application, I believe a screw jack works better than a hydraulic jack.

To use, first install the lower units and set the prop on top of one (protecting the countertop with plywood). With the upper cabinet balanced on the prop, screw the jack up until the upper unit contacts the ceiling. Leveling and plumbing can be done after the top band has been anchored to the wall (I use dry-wall screws). —James E. Gier, Mesa, Ariz.

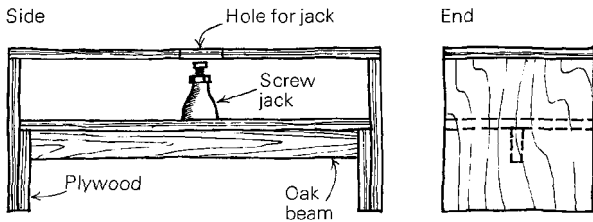

Doweling T-jig

A T-jig, used in doweling edge joints, ensures alignment of dowel pins and holes. Boards joined with the jig will mate better on the finish side, and sanding or planing misaligned joints is virtually eliminated. The jig's bar and leg are made of steel. High-carbon steel is best (anneal for machining, then harden later), but cold-rolled, mild steel will do. Wood will wear too fast. Drill common-dowel-size holes ($\frac{1}{4}$ in. and $\frac{3}{8}$ in.) in the center of the $\frac{3}{4}$ -in. bar on each side of the leg. Two alien-head machine screws secure the leg to the bar.

In use, the T-jig serves as both a gauge (all the pin holes are

equidistant from the face) and a copier (all the pin holes are mated from one edge to the other). First use the jig to drill all the pin holes in board A. Clamp the leg of the jig to the face of the board. No exact measurement of pin locations is needed—the holes in board B will be copied from the pins in board A. Install an extra-long registration pin in the first hole and regular-length pins in all the other holes.

Now clamp the jig to board B (leg to face) and drill the registration pin hole. Place the T-jig over one of the regular-length pins on board A, leg up, and fit the registration hole over the registration pin. Clamp the jig in place on board B, remove the board and drill. Repeat this operation for each pin in turn. Cut and use 1-in. spacer blocks to aid the pin-copying process.

After all the holes are drilled, trim the registration pin to

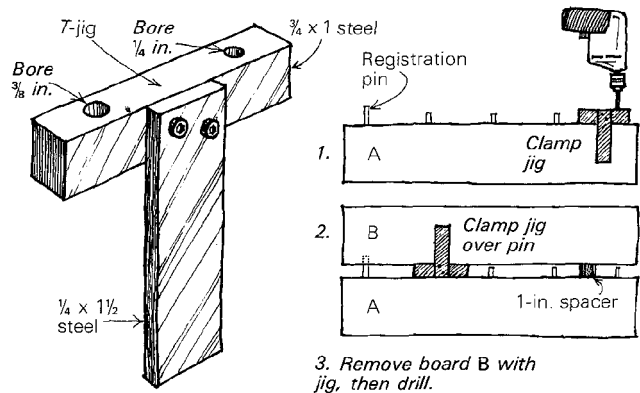

size, spread glue on the joint and press the boards together, keeping the ends even as the boards go together.

— Wallace Smith, Newport Beach, Calif.

Checkerboard

Here's how I build a 16-in. checkerboard with a tenth of the work and time of the individual-square method.

First, saw and joint three strips of light wood and three strips of dark wood (like walnut and birch), each exactly 2 in. wide and 19 in. long. Now saw one strip dark and one strip light, 3 in. wide by 19 in. long, and joint one edge of these wider pieces. Edge-glue these eight strips together, alternating dark and light. Put the 3-in. strips on the outside, to build in a buffer strip for clamping.

When the glue has dried, square up one end, saw one wide (2 ½ in.) strip, then saw and joint six 2-in. strips. You should have one wider strip left over, making eight in all. Reverse four of the strips end for end and glue up. You will end up with an oversize 16-in. board that needs only to be sawn to size. This approach leaves the grain in all squares running the same direction. To build a board with alternating grain in adjacent squares, glue up a 19-in. wide, 10-in. long board of either the dark or light wood. Slice three 2-in. by 19-in. strips, and one 3-in. by 19-in. strip off the end grain. To avoid problems with end-grain butt joints, you could use thin (¼ in.) stock and laminate the completed board to ½-in. plywood.

—G. VanderStoep, Pittsfield, Ill.

Glue up alternating strips.
Slice. Turn every other strip
end for end.

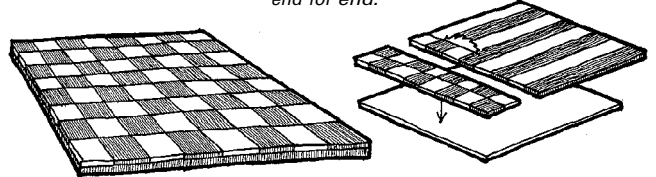

Laminate to plywood for extra strength.

Unwinding lumber

Here's a method for recovering short lengths of twisted lumber. First tack a strip (wider than the lumber is thick) to one edge. Lay the work on the saw table and tack an identical strip to the other side so that both strips lie flat on the saw table and are precisely parallel. Now run both sides of the work over a dado head (or flat, three-lipped cutter) to obtain a flat board.

—Pendleton Tompkins, San Mateo, Calif.

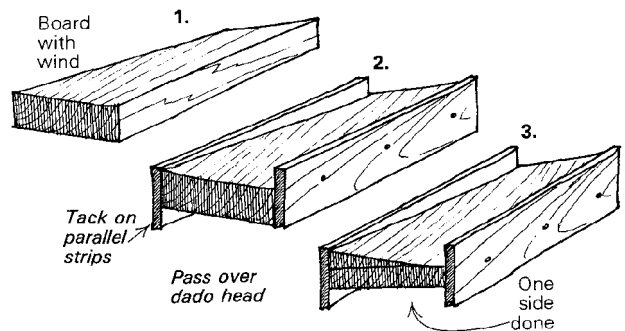

Cutting splines

This simple technique for cutting snug-fitting splines reduces the time and eliminates the frustration of the trial-and-error approach. First mount in the table saw a fine-tooth plywood

Methods of Work *(continued)*

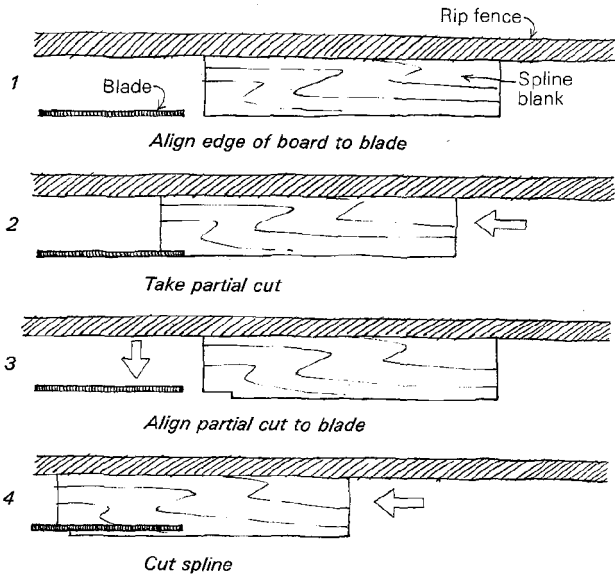

blade, to be used for the entire process. Cut the spline grooves, for a 3/4-in. spline, just slightly deeper than 3/8 in.

To cut the splines, make a partial cut (1/2 in. or so), removing one full, exact saw kerf from the edge of the 3/4-in. spline stock. Now readjust the rip fence so that the left side of the blade is aligned with the right side of the previous kerf cut. Pass the stock through the blade to produce a spline that is the exact size of the grooves.

— Thomas S. North, Bloomfield, Conn.

A replacement for rags

Before I discovered the bonded cellulose wipers I now use for oil and wax finishes, I used cloth rags. After I accumulated a pile of the dirty rags I cleaned them by first dunking in a solution of acetone and dry-cleaning fluid and then sneaking the batch through our washing machine. The cleaning solution was nasty and the whole process a headache.

Now I use Wyp-Alls, an industrial paper towel manufactured by Scott. I assume other paper companies market similar products. By the case, the 13x15 cloth-like wipers sell for a little over 4¢ each. The paper towels, which are designed for use with oil and solvents, work as well as, and perhaps better than, cloth.

— Bill Huggins, Issaquah, Wash.

Another lathe chuck

This easy-to-make lathe chuck simplifies turning small bowls and other faceplate work. Mount a solid-wood block to a plywood base and turn a short cylinder with a flared lip as shown in the sketch. For flexibility, cut a saw kerf nearly through the cylinder. Then cut a mortise through the saw kerf and fit two wedges to the mortise. A dowel or bolt through the cylinder's base will add strength.

To use the chuck, bandsaw the blank to shape and mount

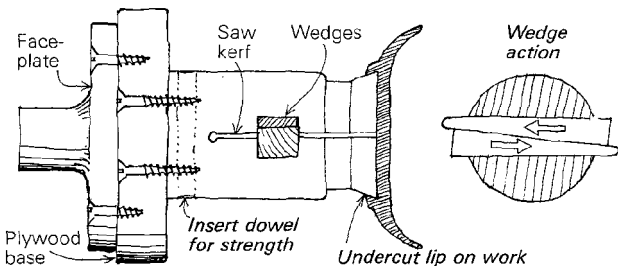

it on a screw center, screwing into what will be the waste from the concave part of the bowl. Shape the outside of the bowl, then carefully undercut a dovetail recess in the base to fit the lip on the chuck. Remove the stock from the screw center and the screw center from the lathe, attach the chuck, then slip the work over the chuck's lip, carefully orienting the grain to take the pressure. Drive home the two wedges to spread the lips and lock the work in place. For safety's sake, wrap a band of masking tape around the wedges to prevent their flying out.
—W. W. Kelly, Clinton, Tenn.

Drawer joint

This rarely seen drawer joint is my favorite for fine furniture. Properly fitted, it is strong and attractive. The initial cuts, made on the table saw, are similar to those used for the familiar drawer joint. Then cut the tenons with a backsaw, chopping out the waste with a chisel. Tap the tenons into the side

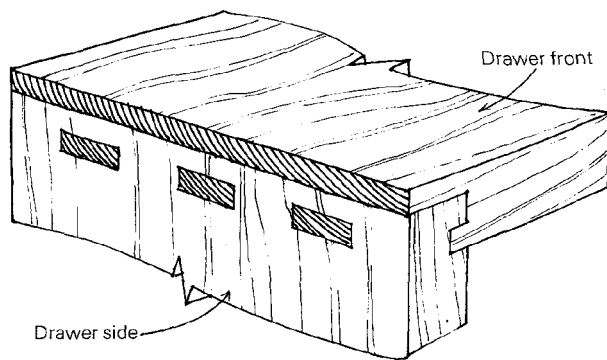

groove and mark the mortise locations. Complete the mortises with a small drill, coping saw and file.
—John W. Wood, Tyler, Tex.

Cleaning file teeth

A blind sharpening-shop operator showed me this simple file-cleaning tool—it works better than a file brush. Hammer flat the pointed end of a 16d or 20d nail and grind the front edge straight. Remove the head of the nail and fit into a drilled dowel handle. Now push the straight edge of the tool along the grooves of file teeth. Soon tiny teeth will form in the edge of the tool which push metal, grease and rust out of the file. Turn the tool on edge to remove stubborn particles in one or two file grooves.
—John Foote, Clarksville, Tenn.

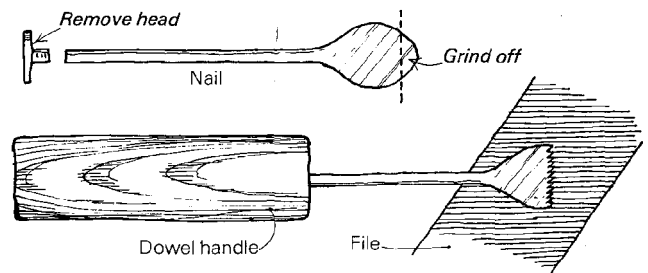

Quick-adjust picture-frame clamp

The key to this quick-adjust picture-frame clamp is the split-nut tighteners, tapped cylinders, which can be opened to disengage from the threaded rod and slid close to the corner

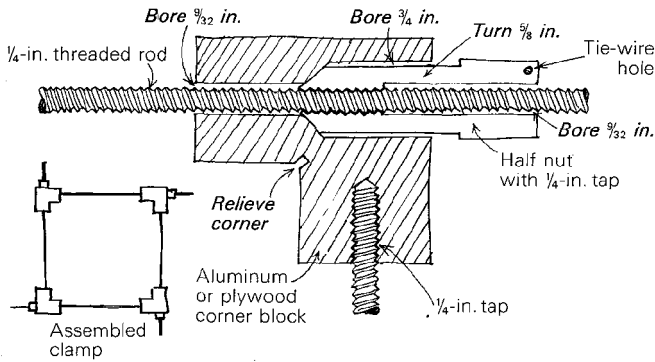

blocks. This allows the clamp to be tightened at any size with only a few turns. The corner blocks can be made from either plywood or aluminum (try the high-school metal shop for casting work). To make the split-nuts, center two pieces of $\frac{3}{8}$ -in. by $\frac{1}{4}$ -in. by 2-in. cold-drawn steel in the four-jaw chuck of a metal lathe. All operations can be made from this initial setup, except boring the relief and the tie-wire holes. To keep the nut halves in mating pairs, pass a short piece of braided flexible cable (used on radio and TV drum drives) through each nut half and secure each wire end with a ball of solder.

—Brad Dimon, Swanton, Vt.

Chisel rabbet plane

The rabbet plane is not needed often in a modern electric shop. But when it is, nothing else will quite do the job. This design, using a standard $\frac{1}{2}$ -in. chisel for the plane iron, requires a minimum of both cash and intricate work. For the

body, laminate three pieces of hardwood as shown in the sketch. A $\frac{7}{8}$ -in. step from the outside laminates to the middle one should be adequate to handle most rabbet depths. The middle lamination should be just slightly thicker than the chisel is wide, then dressed down with a rasp after assembly. Bandsaw the laminated blank to the desired shape, install a $\frac{1}{4}$ -in. steel pin across the throat, then fit a wedge to hold the

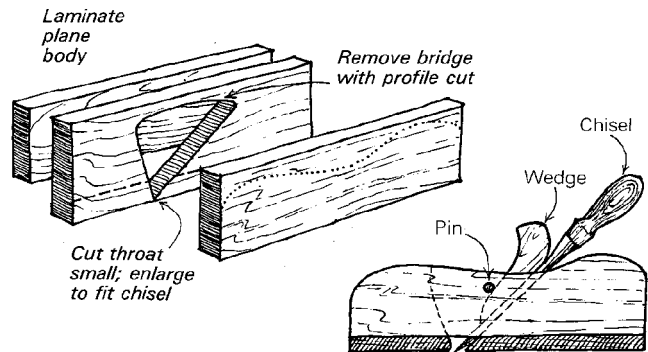

chisel in place. Saw the initial throat opening small, then enlarge it a little at a time with a file until the clearance is right. If shavings clog in the throat, drill a 1-in. hole above the throat to give room to push the shavings out.

—Robert M. Vaughan, Roanoke, Va.

Methods of Work buys readers' tips, jigs and tricks. Send details, sketches (we'll redraw them) and photos to Methods, Fine Woodworking, Box 355, Newtown, Conn. 06470.

Methods of Work

Adjustable tool rest

Here is an adjustable bench-grinder tool rest that's accurate, easy to use and cheap to build. Cut a 1½-in. thick pine hinge-block at the angles shown and mount it to the base with screws from underneath. Cut down two Stanley 10-in. lid supports to make the table-adjusting hardware. Drill out the center rivets and replace with screws into the 1x1 hardwood block. Pin the ⅜-in. threaded rod in a mortise in the pine hinge-block. Now mount the plywood or Formica-covered, composition-board table as close to the grinding wheel as possible.

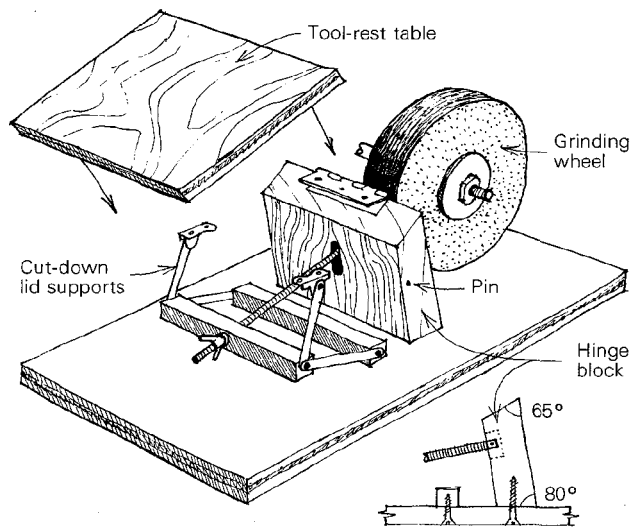

sible. Recess the hinge into the bottom of the table if necessary.

—Mike Perrin, Knoxville, Tenn.

Sanding block for lathe work

For years my woodworking students invariably burned their fingers sanding bowls and other lathe work. Then I hit upon the solution—sanding blocks cut from sheets of ½-in. thick rubbing felt. The felt sanding block shapes itself to shallow curves and can be deliberately shaped to match any contour of a compound curve.

Rubbing felt is available in 1-ft. squares from H. Behlen & Bros. (Box 698, Amsterdam, N.Y. 12110) and other suppliers. A similar material, used for typewriter cushions, is available from office-machine suppliers. Cut the pad with a razor knife and rule. One block lasts indefinitely.

—Russell Anderson, Torrington, Conn.

Making little wooden balls

Faced with having to reproduce a number of ½-in. diameter wooden balls (to replace missing ornamentation on an old fireplace), I discovered a virtually painless procedure using a large belt sander. Build a box frame, open on the bottom, and clamp it to the stationary part of the sander so it sits just off the belt. For ½-in. diameter balls, cut ½-in. cubes and toss them in the box frame. Put a cover on the box (Plexiglas is best) and turn on the sander. The sanding belt will throw the cubes around in the frame like dice on a game table, knocking off their corners and edges until they're perfect spheres.

If the cubes don't tumble about but rather line up neatly against the far wall of the frame, glue a wedge there. If this doesn't work, you could vary the number of cubes, presand

Clamp frame
to sander
just above belt

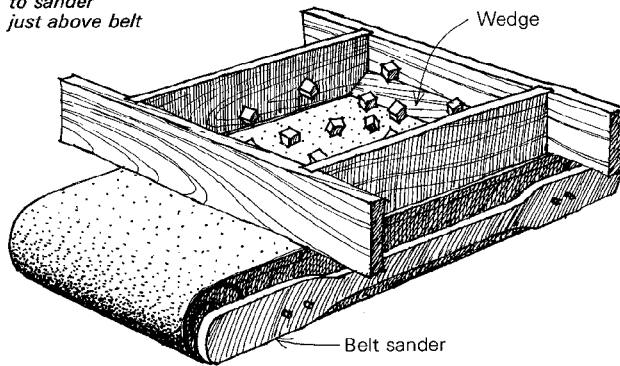

the corners or throw in a few ball bearings to keep the cubes tumbling. Using this method, I produced a dozen or so perfectly shaped balls in an hour's sanding time. Had I shaped the balls by hand it would have taken longer and the result would have been less uniform. Perhaps laziness really is the mother of invention. —Charles Reed, Washington, D. C.

EDITOR'S NOTE: Starting with rectangular blocks you can use Reed's technique to produce oval shapes.

No-mess doweling

To reduce the glue-all-over-the-hands, sticky mess that goes with dowel work, cut the spout off the glue bottle until the dowel pin just fits inside. Slip a dowel pin into the spout, then invert and squeeze the bottle to cover the dowel with

glue. Turn the bottle right-side-up and twist the dowel out. No mess, no fuss. —E. Khalsa, Espanola, N. Mex.

Recessed tabletops

Wasting the central area of a top to form a lip on a bedside table or bureau is attractive and functional. Recessing emphasizes the grain, shows that solid wood has been used and prevents pencils and spills from falling to the floor. I cut the recess on the table saw using a dado head with all the chippers to get the widest cut. The circumference of the dado head leaves a pleasant curve at the inner edge of the tabletop.

To cut the recess, first clamp blocks of wood to the saw's rip fence to serve as stops. Then set the dado head to the right depth ($\frac{1}{4}$ in. suits my taste). Holding the wood against the back stop, carefully lower the tabletop into the dado head. Do not cut across to the near edge, as it's liable to split out. Instead, cut halfway across, reverse the tabletop and cut halfway again from the other edge. Waste the bulk of the mater-

1. Lower work onto dado head

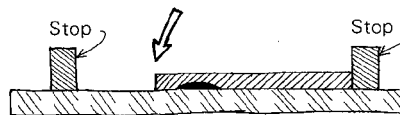

2. Cut halfway

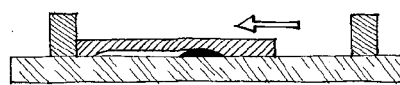

3. Reverse work, cut from other edge

Tabletop after cutting

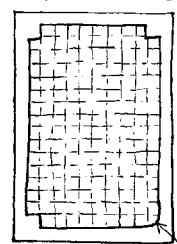

Hand-carve corners

ial by cutting crossgrain, repeat passes along the grain, then carve out the corners by hand. Finish the surface by scraping and sanding. —Pendleton Tompkins, San Mateo, Calif.

Deep-throat clamp

If you need a deep-throat clamp and none is available, substitute a conventional C-clamp and two blocks of wood arranged as in the sketch below. Though direct pressure is less than with expensive specialty clamps, the system works fine for gluing inlays, guitar bridges and other simple joints.

—Bob Qsbahr, Tucson, Ariz.

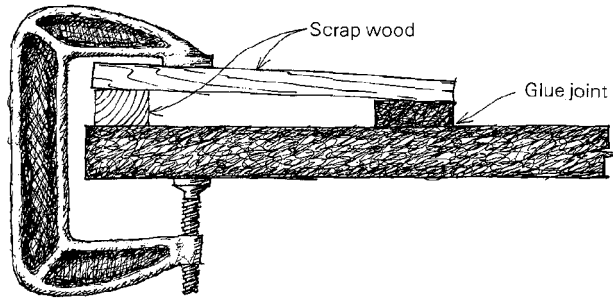

Clamping wide boards

In bookcase construction and other large-carcass work, it is often necessary to join wide boards in an *H*. Without special clamps, it is difficult to achieve the necessary clamping pressure. This simple crowned caul, used with ordinary bar clamps, solves the problem.

To make the caul select a 1-in. thick, 2-in. wide block as

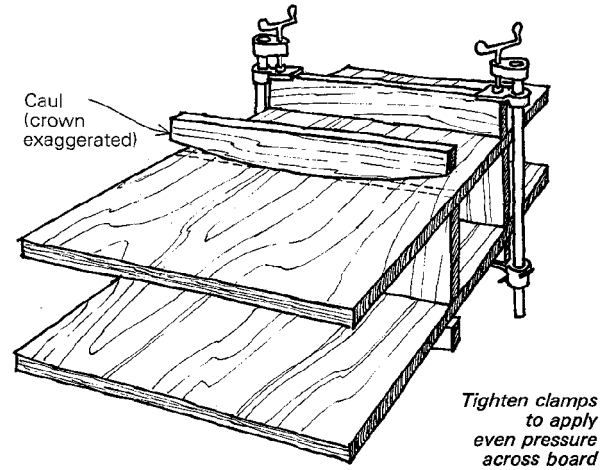

long as your lumber is wide. Plane a crown on one edge, leaving the center high and each end about a degree lower. Now lay the caul, crown edge down, across the width of the board to be clamped. As you apply pressure to each end with bar clamps, the end-gaps will close, resulting in even pressure across the joint.

—David Shuffer, Silvercliff, Colo.

Square cuts

Most table-saw and radial-arm-saw blades that I've worked with have a tendency to climb and squirm when crosscutting. The result is an out-of-square cut. I've found, quite by accident, that if the crosscut is very thin, say one half the kerf, the saw cuts amazingly true. This approach does require that you

make two cuts—one to rough length (leaving a half-kerf extra) and the second to final length. Of course if the machine is out of square to begin with, all bets are off.

—Pat Warner, Escondido, Calif.

Preventing tear-out

The problem of excessive tear-out at the bottom of drill-press holes can be solved with a simple metal collar. I discovered the collar solution during a 30-unit production run of a small piece of furniture. Each unit required a drilling operation of eighteen holes in warped 1x12 pine. Without question, the tear-out problems I experienced were because the warped stock was inadequately supported on the drill table.

I'm aware that the classic prevention for tear-out is to support the stock to be drilled with a scrap back-up board. This I wished to avoid because of the hazard, nuisance and expense. I used my small metal lathe to turn a substitute for the back-up board—a steel collar with a 1/32-in. protruding lip to com-

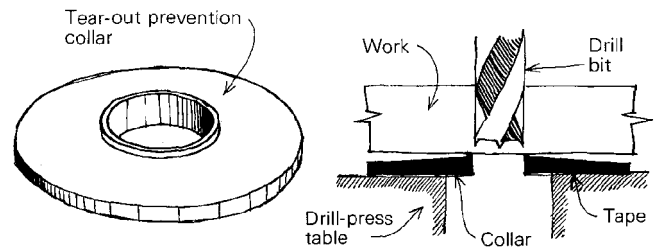

press and support the wood in the area of the hole. When the wood is adequately supported and compressed in advance of the rotating bit, the result is a clean hole.

The profile of the collar is shown in the sketch. Except for matching the collar's bore to the drill bit used, the dimensions are arbitrary. Turn the bottom of the collar flat (perhaps even a shade concave) to prevent the collar from rocking.

To install the collar on the drill press, put double-sided tape on the bottom of the collar and slip it over the drill bit. With the bit lowered into the table, carefully slide the collar down and press it onto the table. Counterboring the hole in the table will prevent shavings from jamming the collar hole.

— Carl Hogberg, North Chatham, Mass.

Triangular scraper

This gaunching tool (that's what we called it in the old days back in New England) is used for deburring metal, enlarging holes, scraping paint or glue from hard-to-reach places and many other jobs where a sharp, hard tool is necessary. Break off an old triangular file, hollow-grind it to the shape shown and mount in a handle.—H. Norman Capen, Granada Hills, Calif.

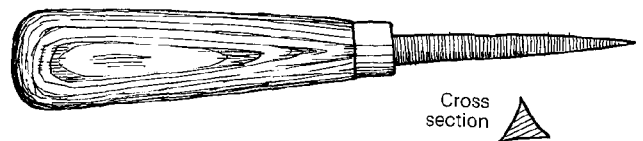
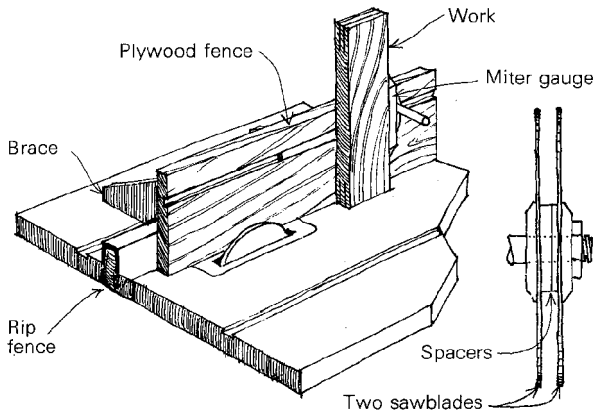

Table-saw tenons

This method for cutting tenons on the table saw uses two blades with spacers between. The beauty of this system is that the tenon thickness is "locked in" and does not depend on variables such as stock thickness or pressure against the fence.

I keep a pair of special hollow-ground blades for tenon work. They are jointed as a pair and filed for ripping. Since the hub and tooth thickness are the same, cutting a 1/16-in.



tenon, for example, simply requires mounting the two blades with a $\frac{1}{4}$ -in. and a $\frac{1}{16}$ -in. spacer between. My set of custom-machined spacers are $2\frac{1}{2}$ -in. discs drilled to slip over the saw arbor. Spacer thicknesses range from $\frac{1}{4}$ in. to 0.005 in. To pass the work through the blades, I use a standard miter gauge tracked in a plywood fence as shown above. This approach eliminates vertical rocking and thus is safer and more accurate than other methods.

—Mac Campbell, Harvey Station, N.B., Canada

Sharpening jointer knives

Here is a jointer-knife sharpening jig that saves money, eliminates frustrating at-the-sharpening-shop delays and gives the woodworker a bit more independence. The jig, used with a drill press and cup stone, consists of a $\frac{3}{4}$ -in. plywood or particle-board base and a sliding knife-holder. The holder, slotted to accept the jointer knife at the right sharpening angle, slides in an accurately sized channel in the base. Several thumbscrews, tightened in threaded holes, threaded inserts or T-nuts, lock the knife in the holder slot during grinding. (To tap wood, drill pilot holes, use a tapered tap and back the tap out often; maple and other hardwoods tap about like hard brass and hold as well.)

To use the fixture, chuck a medium-grit $1\frac{1}{2}$ -in. cup stone (contact Norton Co., 1 New Bond St., Worcester, Mass. 01606 for distributors) in the drill press. True the stone if necessary (I use an old masonry blade). Then clamp the base in position on the drill-press table so the knife and stone are aligned as shown in the sketch. Lower the quill until the stone barely touches the knife, lock the quill and grind the knife by sliding the holder under the stone. Lower the quill a bit and grind again. Repeat this operation until all nicks have disappeared. When the final depth is reached on the first knife, set the drill-press stop to preserve the setting for sharpening the second and third knives.

To avoid warping the knife by heating unevenly, take light cuts, move the holder smoothly and use plenty of thumb-

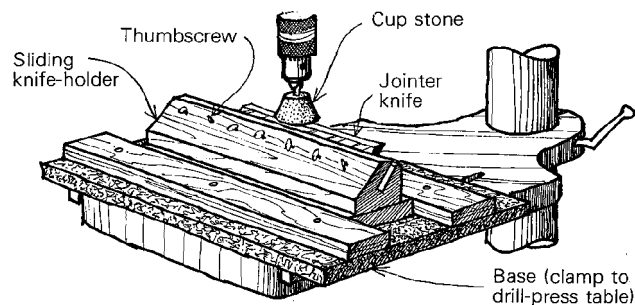

screws to lock the knife in the holder. Long knives are especially prone to warping, so mist them or let them cool between passes.
 —James E. Gier, Mesa, Ariz.

Decorating turned goods

To produce decorative black rings on tool handles and other lathe work, twist a dowel peg handle on each end of a 12-in. long piece of soft iron wire. Any medium-gauge wire will do.

To use, scribe a shallow starting groove in the work with the point of a skew. Then press the wire against the starting groove. In five or ten seconds friction will generate enough heat to scorch the groove. The resulting fine black ring, sparingly used, gives a tasteful decorative effect.

—Larry Joseph, Alva, Okla.

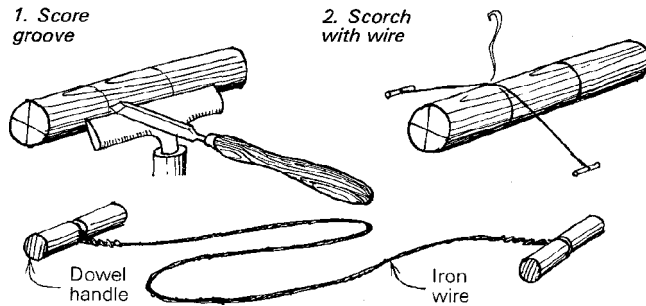

Turning ringed objects

An effective mandrel for turning napkin rings and other annular objects can be made as follows. Choose a suitable hardwood (such as hard maple) and mount the wood to the face-

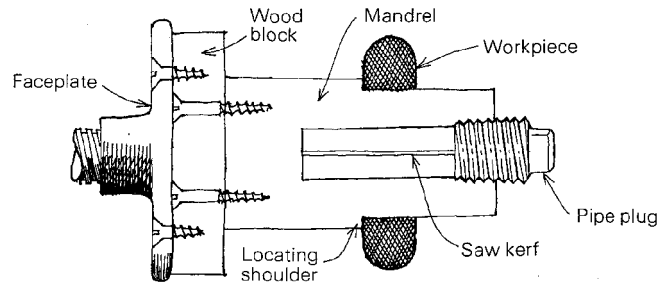

plate with the grain oriented perpendicular to the axis. Turn down the end of the mandrel to give a slip fit with the workpiece, leaving a larger-diameter locating shoulder on the base as shown in the sketch. Next, drill and tap the end of the mandrel for a tapered pipe plug of suitable size. First select the recommended tap drill size for the pipe thread and drill into the end of the mandrel $\frac{3}{4}$ in. or so deeper than the locating shoulder. Then tap the hole so that a pipe plug will thread in halfway. The resulting threads, though rough in appearance, are quite strong if the grain is oriented as suggested. To complete the mandrel, cut two crossed saw kerfs to the same depth as the hole.

To use, slide on the workpiece and screw the pipe plug in the hole. The plug will expand the mandrel, gripping the workpiece firmly.

—Edward F. Grob, Naperville, Ill.
 and Charles E. Cohn, Clarendon Hills, Ill.

Methods of Work buys readers' tips, jigs and tricks. Send details, sketches (we'll redraw them) and photos to Methods, Fine Woodworking, Box 355, Newtown, Conn. 06470.

Methods of Work

Two router-table/table-saw extensions

My shop is too small to endure much more big equipment. So when I needed both a router table and additional outfeed support on my table saw, I combined both functions in the extension table shown in the sketch. Since the table is bolted to the saw, alignment between extension and saw table is better and the table is easy to clean under.

I made the $\frac{3}{4}$ -in. flakeboard table 32 in. wide. Added to the saw table, this gives 44 in. of support. Leave a gap be-

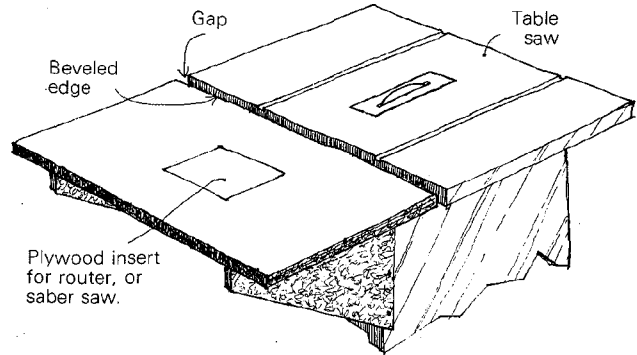

tween the saw table and extension so that a plywood panel can be ripped, then crosscut with a saber saw without moving the panel off the table. The blade will travel between saw table and extension. Bevel the front edge of the table so it won't catch work as it leaves the saw table. Cut a 10-in. square hole in the middle of the outfeed table to hold a router or saber saw mounted on 10-in. plywood inserts. Cut another insert blank to fill the hole when not in use.

—W. Davis Smoot, Duncanville, Tex.

By mounting a router table to the side of the table saw as shown, you can combine the control of the saw's miter gauge and rip fence with the safe, crisp cuts of the router. You'll find the saw's miter gauge useful in cutting cross-grain dadoes, dovetails and finger joints. Cut mortises, tenons and with-grain grooves using the saw's rip fence. The combination saves shop space and increases the surface area of your table saw. There's no need ever to remove the router table—just lower the bit when not in use.

—Mark Duginske, Wausau, Wis.

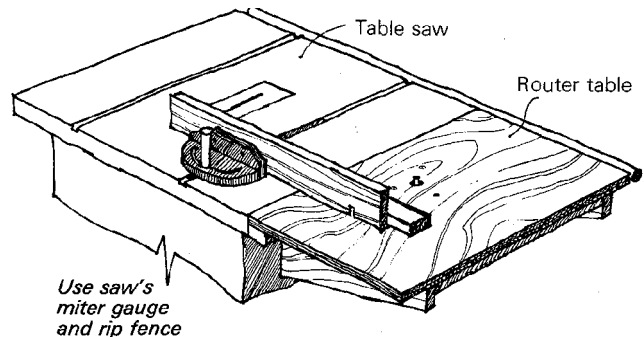

Bench-top hold-down

An old steel roofing square makes an excellent workbench hold-down and glass-cutting aid. Drill mating $\frac{3}{8}$ -in. holes in the ends of the long side of the square and in the bench top. Insert 1-ft. lengths of $\frac{3}{8}$ -in. threaded rod through the holes with washers and wing nuts above and below. For cutting glass, make two short sections of non-threaded $\frac{3}{8}$ -in. rod

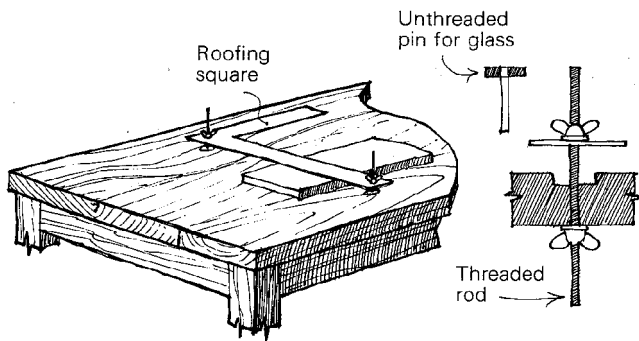

capped with dowel heads to use in place of the threaded rod. The non-threaded pins are easier to install and remove. Use the shorter side of the square as a backstop or measuring aid. If it's in the way, just flip the square over.

—Malcolm McKeag, Peace Dale, R.I.

Making miniature shingles

To make small wood shingles for miniature buildings, start with a length of straight-grained 2x4. Any softwood will do, but white cedar is best as it is quite flexible. To make pointed shingles, cut $\frac{3}{8}$ -in. notches across the end of the 2x4 with a band saw, using a regular (not skip-tooth) blade. To make square-end shingles, substitute a series of $\frac{1}{2}$ -in. saw kerfs for the notches. Now cut off a $\frac{7}{8}$ -in. length from the notched (or kerfed) end of the 2x4. Continue notching and cutting off $\frac{7}{8}$ -in. blocks until you have plenty to complete the job.

To prepare your band saw for slicing gang shingles from the blocks, saw straight into the center of a piece of $\frac{1}{4}$ -in. plywood and stop. Clamp a wood fence on top of the plywood and as close to the blade as the thickness of shingle you want ($\frac{1}{16}$ in. or so). Use a push-stick to hold the block snugly up against the fence. Slice gangs of shingles from the block until the block is cut down to $\frac{1}{4}$ in. Glue this remnant to the next block to be sliced.

Alternately, the slicing operation can be done on the table saw using a fine-tooth plywood blade. To keep the thin slices of shingle from falling through the space beside the blade, tape a thin, flat board to the saw table against the rip fence and over the blade. Elevate the blade through the board to provide a gap-free surface.

You should taper by hand the first course of shingles around the eaves of your miniature building. If you don't, the second course won't lie right. To accomplish this, build a hand clamp (useful for other work as well) from two pieces of hardwood and a hinge as shown. Pinch a gang of shingles in

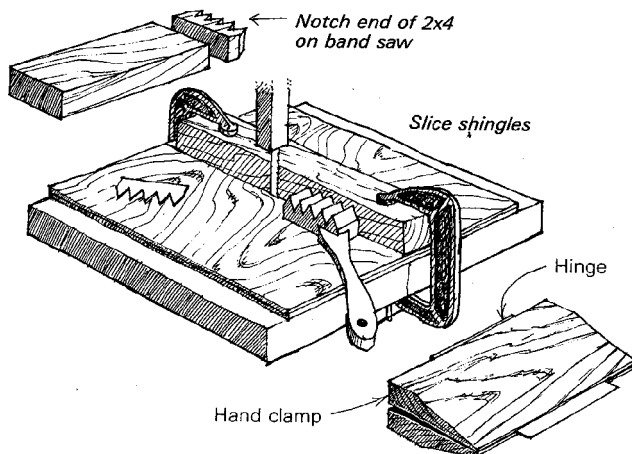

the clamp (points in) and feather the back end of the shingles by pressing lightly on a belt sander.

To install the shingles, match up the ends and glue in place on a line. Hold each row in place with masking tape until the glue sets.

—Floyd L. Lien, Aptos, Calif.

EDITOR'S NOTE: Some miniaturists use a hot-glue gun to fasten down gang shingles. Since the glue sets in seconds, it is possible to shingle an entire roof in a single session.

Correcting veiner flaws

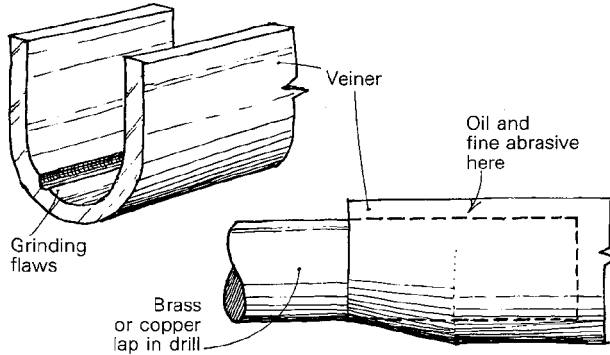

I bought a veiner carving tool with grinding imperfections that made it impossible to sharpen. The inside radius wasn't true and the inside face was grooved. I chucked a brass rod (copper works as well) in my drill and lapped the inside face using fine silicon-carbide abrasive and oil. It trued the radius and eliminated the groove. —Ellis Thaxton, Arlington, Tex.

Tool holders

This tool holder is simple to build from scrap lumber and Masonite. The hole spacing can be varied for different tools. A mounting hole on each end allows the rack to be hung from the wall, the workbench or even a door.

—Jay Wallace, Gilbert, Ariz.

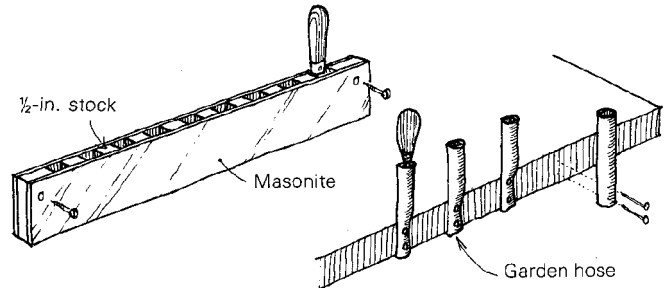

Six-inch lengths of garden hose fastened to the wall or bench with two nails at the bottom make excellent tool holders for screwdrivers, awls, etc. Tools are easy to remove, and the soft, flexible hose won't damage sharp edges.

—Carl R. Vitale, Cranston, R.I.

Heating the shop

Heating a woodworking shop can be a problem—sawdust and paint vapors present a fire hazard. Local heating firms suggested several approaches including a separate "heating room," a gas wall heater, infrared heating and electric baseboard heating. All these approaches were either too expen-

sive, a fire hazard or both. Finally, I chose electric hot-water baseboard heat for my just completed 14-ft. by 22-ft. wood-working shed. I was a little worried about the operating cost, but surprisingly, costs have been only slightly higher than gas heat. The unit keeps the water at an even temperature and doesn't cycle on and off like other heating systems. Hot water baseboard units weigh less than 30 lb. and can be purchased as portable or permanently mounted models. They don't stir up the air—an ideal situation for a dusty shop or paint room. Because the units operate at a continuous low heat; they're not a fire hazard.

I chose the largest model the supplier had—a 220-volt portable unit that sells for about \$150. It measures 4 in. by 9 in. by 107 in. long and produces 6,800 BTU. The supplier: Intertherm Inc., 3800 Park Ave., St. Louis, Mo. 63110.

—R. Voorhees, Ft. Wayne, Ind.

Reversing belt-driven tools

It's easy to reverse disc sanders and other belt-driven tools if the motor is mounted perpendicular to the shaft it drives, so there's a quarter-turn in the belt, as shown. To reverse, simply loosen the belt, flip 180° (on either pulley) and tighten. The twist in the belt seems to dampen vibrations—an added advantage.

—Roger Lynne,
Bloomington, Minn.

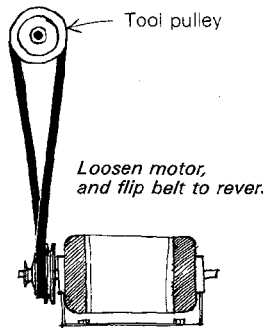

Picture-frame clamp

This picture-frame clamp beats anything else I've tried. Make the device from 3/4-in. thick, 2-in. wide hardwood strips. I covered the hardwood with smooth Formica for extra strength and for freer action of the parts. You'll need four 16-in. legs, two 4-in. connectors and four 2-in. discs notched to hold the corners of the frame.

To use, determine the positions of the notched discs on the legs through a dry run. When everything is ready, apply pressure to the frame using a parallel-jaw wooden clamp across the center connectors.

—John L. Van Scoyoc, Bartlesville, Okla.

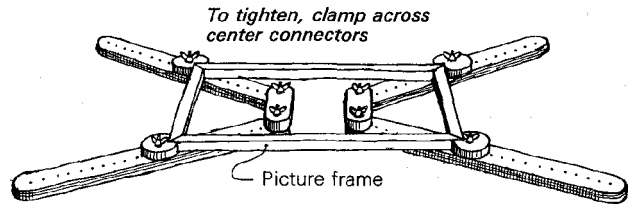

Ferrules from end caps

Over the years I have seen all kinds of homemade tool handles ranging from an old corncob jammed on the tang of a rasp (a surprisingly comfortable improvisation) to ornate, French-polished creations. For most of us whose efforts fall between these extremes, locating a suitable ferrule is a larger problem than turning the handle. Plumbing stores stock an attractive, inexpensive solution—copper-tubing end caps. The end caps, available in several sizes, are tough enough to

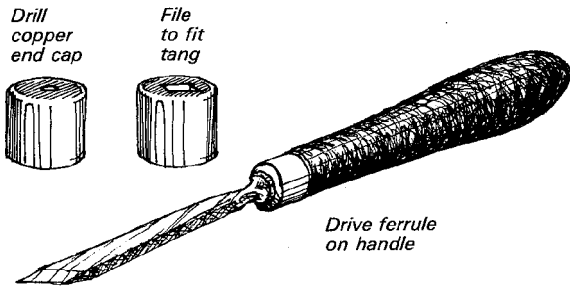

hold up to mallet blows. To make a ferrule, drill a hole for the tool's tang through the soft metal. Shape the hole, if necessary, with a needle file. Drive the ferrule onto the wood handle, which has been sized to give a tight friction-fit. Rubbing the copper with fine steel wool produces a beautiful satin finish and reddish-gold color that complements all woods. An occasional coat of paste wax will protect the copper from tarnish.
 —George Mustoe, Bellingham, Wash.

Cutting circles on the table saw

Round tabletops, lazy-susan shelves and other large circles can be cut on the table saw with a simple jig. Cut a dado in the underside of a 3/4-in. high-density particle-board base and glue in a hardwood key, sized for a sliding fit in the saw's left-hand miter slot. Wax the jig bottom and key to reduce friction. Measuring from the blade, accurately locate and paste sheets of 3/4-in. graph paper to the jig top to aid in layout.

To use, first cut the circle blank somewhat oversize and locate its center. Next mark the radius of the finished circle on the graph paper and pin the center of the circle blank at

this mark. Make sure the blank will rotate freely but is firmly pinned to the jig. Start by lopping off the corners of the blank. Hold the blank and jig firmly while sliding them past the blade. If hand-holding the work appears unsafe, mount a hold-down clamp on the base to lock the blank while cutting. Continue cutting off the corners of the blank until it is almost round. Then, with the work just touching the blade, rotate the blank to trim off all the high spots. The smoothest circles are produced using high-quality, sharp carbide blades.

—Philip Margraff, Coeur d'Alene, Idaho

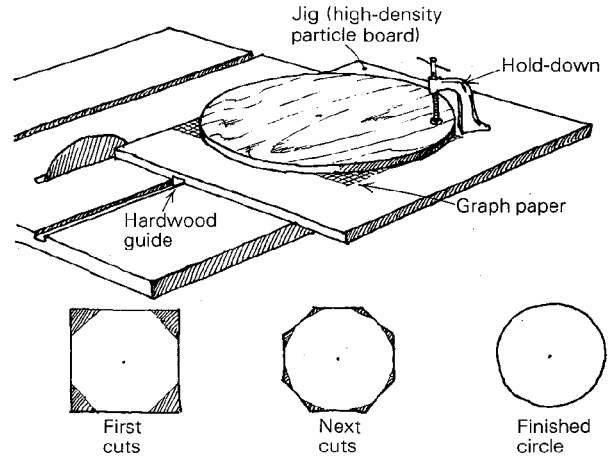

Methods of Work buys readers tips, jigs and tricks. Send details, sketches (we'll redraw them) and photos to Methods, Fine Woodworking, Box 355, Newtown, Conn. 06470.

Methods of Work

Four ideas for edge-finishing plywood

Here's how to edge-finish plywood and match the color and grain exactly. Buy enough extra plywood so you can saw strips from the edge and ends of the panel slightly wider than the plywood is thick. Now saw off the face veneer from the strips using a thin-rim plywood blade on a table saw. To prevent the

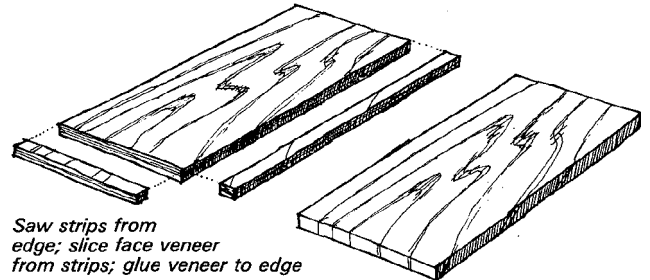

veneer from falling through the gap between blade and table insert, tape a piece of $\frac{1}{4}$ -in. plywood to the saw-table top and elevate the blade through it. If you are careful in sawing the veneer, you can match the edge strips with the face to create a continuous grain pattern that's quite attractive. Glue the strips in place, then sand off the slight overhang.

—Floyd L. Lien, Aptos, Calif.

On a recent platform-bed project I needed to glue $\frac{1}{4}$ -in. oak strips to the edge of a plywood panel. Only two of my bar clamps were long enough for the job. Luckily I hit on a way to combine the two clamps with a double-wedge clamping method I use in guitar construction. I simply clamped a stur-

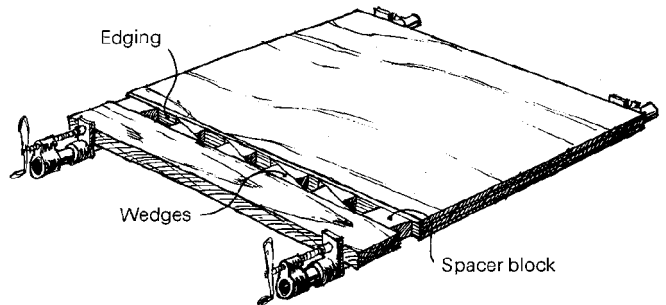

dy oak 1x4 to the edge I wanted to glue, separating the board from the edge with two spacer blocks. The resulting gap left room all along the edge to drive home pairs of wedges. The system worked better than I expected. I was able to control the clamping pressure at many points along the edge without wrestling with a lot of clamps.

—Willis Overholt, Wichita, Kans.

In the small custom furniture shop where I worked some time ago, we glued solid oak edging to the unsightly edges of fibercore, oak-veneer panels. Because this required a bar clamp every 8 in. for a tight joint, we soon depleted our supply of clamps, time and patience. My solution is a springboard which applies even pressure to the edging using far fewer clamps. Cut the springboard about 20 in. long from $\frac{3}{4}$ -in. thick, $1\frac{1}{2}$ -in. wide hardwood (I used red oak for its resiliency in bending). Plane the middle of the front edge to produce a concave shape, about $\frac{1}{8}$ in. deeper in the center than at the ends. Fasten with screws a couple of sheet-metal fingers to the back edge to hold the springboard in position on the clamp face while you're adjusting the work to be glued. As you tighten the bar clamp and close the gap, pressure will

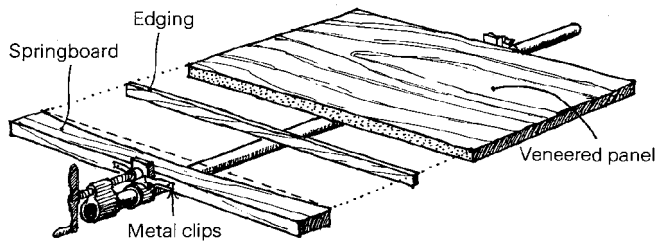

equalize along the concave face of the springboard.
—Michael Mikutowski, South St. Paul, Minn.

I use a hot-water clamp-table to speed up edge-gluing on plywood cabinet parts. When I clamp the plywood and edge strip to the rectangular steel tube (maintained at 160°F by circulating hot water) the plastic resin glue sets in 15 to 20 minutes. I trim the just-glued piece while the next one sets.

The device consists of a hot-water tank, a pump, hoses, fittings, a table and the 48-in. rectangular tube. Two points of caution: Use a pump designed for hot water (check with demolition companies—they salvage these pumps from old buildings) and install a pressure-relief valve. The valve is especially important if your system is closed, as is mine. Cover the work table with plastic laminate and wax so the glue will chip off easily after it has set. Leave a space between the rec-

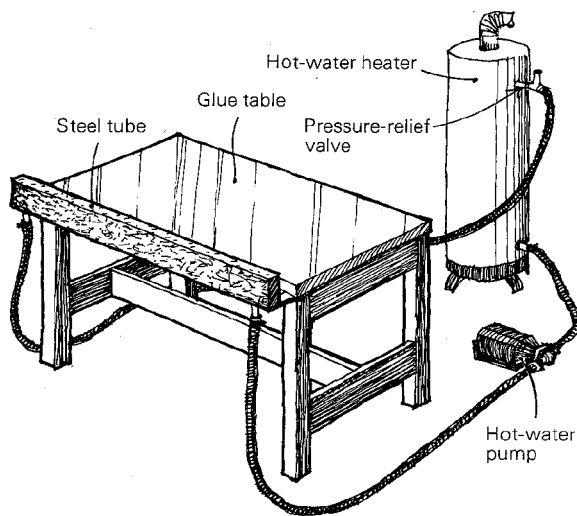

tangular tube and the table so that you can adjust the edging and leave an overhang on the bottom.

To use, apply glue to both surfaces, position the strip, then bring the edge against the hot tube. Start clamping with the plywood angled up slightly so the bottom glueline is tight but there's a gap on top. Apply pressure until the gap closes.
—Richard Esteb, Olympia, Wash.

Sanding block for beaded edges

On a recent mantle clock project I needed to sand the beaded edges without rounding the crisp corners or flawing the uniform curvature of the bead. Hand sanding with a folded sheet of sandpaper would just not do. I made a reverse-image sanding block by routing a cove into a small piece of wood. Then I cut strips of sandpaper and glued them to the cove with 3M's feathering disc adhesive. This adhesive, used by auto body men to attach abrasive discs to disc sanders, was excellent for my purpose. Since it remains tacky, I could attach new strips of sandpaper as the old strips wore out without reapplying the

adhesive. It also works well for attaching wooden protective pads to the jaws of C-clamps and bar clamps.

—John Searles, Xenia, Ohio

Duplicating wood parts

You can produce exact duplicates from a master pattern using this overhanging jig on your table saw. To make the jig, glue the pieces of 1/2-in. plywood in an L, reinforcing the joint with braces and screws. Clamp the smaller side of the jig to the saw's rip fence with two C-clamps. Allow 1/8-in. clearance between the underside of the jig and the stock to be cut. Now, by moving the rip fence, set the guide edge of the jig directly over the outside of the blade.

Cut a master pattern from 1/2-in. plywood to the exact size and shape of the part to be duplicated. Fasten the pattern to oversize precut blanks with tacks or double-sided tape. Now

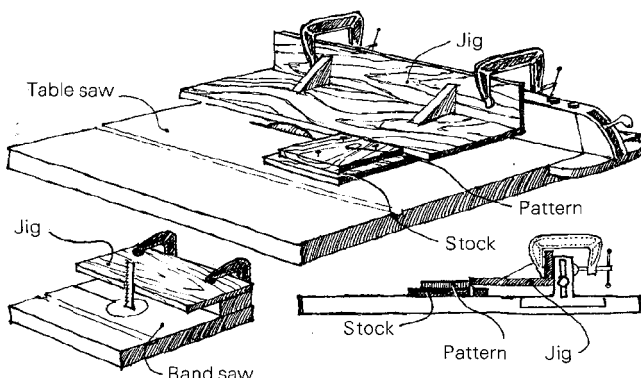

you are ready to cut the duplicate part. Press the master pattern against the guide edge of the jig and push through the blade. For safety's sake remove scraps from under the jig as you cut and stand to one side of the line of cut. Otherwise you'll be dodging projectiles of scrap that pile up under the jig and eventually get fired out by the blade.

The table-saw jig is limited to duplicating straight-edged parts in plywood and thin, solid stock. To reproduce thicker parts, and those with curved edges, set up a similar jig on the band saw.

—Ed Stevenson, Hammonton, N.J.

Hand sander

Here's an inexpensive, quick-to-make hand sander that's effective for smoothing out gouge marks on curved surfaces or for rounding off a sharp edge. You will need some scrap plywood, a used belt from a belt sander and a little contact cement.

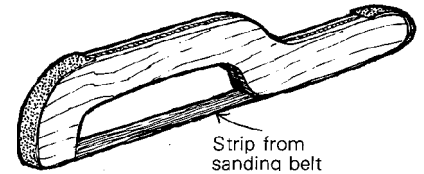

First, cut the plywood into an 8-in. to 12-in. long hacksaw shape. Tear a strip from an old sanding belt as wide as the plywood you use and a couple of inches longer than the frame you cut. Spread a little contact cement on the backside of the strip and along the bottom surface of the frame and press the abrasive strip along the bottom of the handle to the front.

When completed, the sander has an open section with a little give for sanding curves and a rigid section for sanding flat surfaces. The rounded ends are designed for sanding concave surfaces. By changing the shape of the frame, the ap-

plications are virtually endless. When the abrasive is dull, just pull off the old strip and glue another on.

—Richard Neubauer, Jr., Cincinnati, Ohio

Surfacing wide boards

My jointer is small, but that doesn't stop me from surfacing boards wider than 6 in. Say you've found the perfect piece of cherry for a drawer front, but it's 9 in. wide, cupped or slightly twisted. To rip and reglue the board would spoil the gorgeous grain pattern. What I'd do is rabbet the two edges of one surface, run the new narrow width over the jointer, then flatten the top through the thickness planer. Flip the board over and plane the true board to thickness.

Naturally the nature of the cup, bow or twist and the thickness of the finished piece determine the depth of the rabbet. And, if you must rabbet both edges, you'll likely have to remove the regular fence from the jointer to center the work over the blade. —Donald Leporini, Newton Centre, Mass.

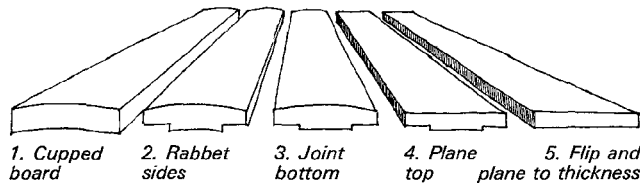

Auxiliary vise

When I acquired a large European workbench, I decided to make an auxiliary vise similar to the one made by Ulmia. Held in the right-hand end vise, the auxiliary vise clamps thin

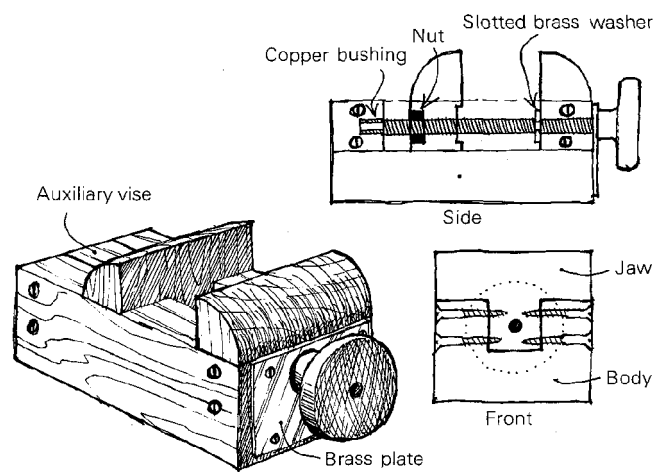

boards or molding for planing. My version uses maple, a piece of 1/8-in. thick brass, a small handwheel and a length of ordinary 3/8-in. threaded rod.

Make the body of the vise by cutting a 1-in. channel in a maple 2x3. Or glue up two or three pieces of maple into a U. Attach the fixed front jaw and the end block with bolts or screws driven in from the sides. Screw the brass plate to the front of the vise to prevent wear by the knob and threaded rod. Drill a hole through the vise and install the threaded rod and movable jaw as shown in the sketch. I reduced the diameter of the end of the rod and bushed the end block with copper tubing. Recess a nut into the back side of the movable jaw and pin the nut in place with a couple of fine screws, or

epoxy it. To keep the threaded rod from slipping out of the vise, file a notch around the rod just inside the front jaw and force a slotted brass washer around the notch as a retainer. Recess the front of the movable jaw to accommodate the washer.
—Ralph Luman, Virginia Beach, Va.

Fluted columns

When building a tall clock case I needed two fluted half-columns 44 in. long. Since my lathe is only 36 in. between centers, I had to turn the columns in two pieces. It would have been almost impossible to match the flutes, match the grain and hide the joint had I tried to make the columns look identical through their length. So I borrowed a trick from a piece of furniture I saw in the Philadelphia Museum of Art.

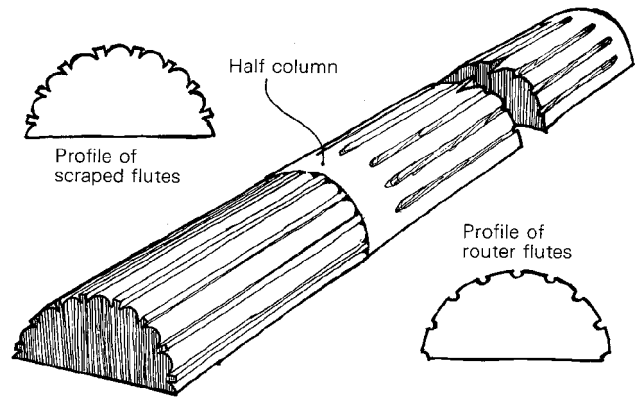

First I glued up two column blanks with paper between (for separation into half-columns later). One blank was turned 35 in. long and fluted with a $\frac{3}{16}$ -in. veining bit in the router, stopping the flutes $\frac{1}{2}$ in. from the ends. The other blank was turned 10 in. long and fluted by scraping with an inexpensive wood chisel ground to produce the shape I wanted. These flutes extend the entire length of the shorter piece. After the columns were split apart into half-columns, the longer sections were simply butt-glued to the shorter sections to produce 44-in. long half-columns. The butt-joint is weak but not critical since the half-columns will later be glued and screwed to the clock face.
—Richard M. Watson, Lindenwold, N.J.

Making dowels

Here's how to make dowels on your lathe with a router. First build a guide box with sides a little higher than the turning stock. Allow about an inch of clearance between the stock and the box walls. Chuck a $\frac{1}{4}$ -in. straight bit in your router and adjust the depth of cut so that when the bit is over the dowel

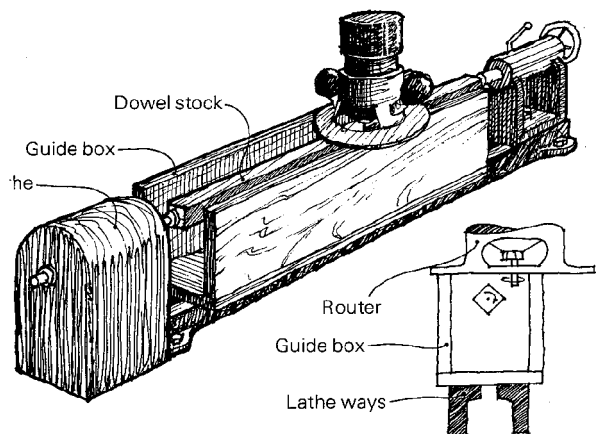

stock it will cut the dowel about $\frac{1}{16}$ in. oversize. Position the router on the downward side of the stock rotation as shown in the sketch. Turn on the lathe, turn on the router and cut away. Take several light cuts to reduce the possibility of the bit grabbing and breaking the dowel. Lower the bit to the final depth and make one final pass with the router centered over the dowel.

—Lee R. Watkins, Littleton, Colo.

Inexpensive homemade clamp

When you run out of clamps and money at the same time, these simple old-timers can be quickly made from wood scraps and an old leather belt. Make up several sizes of end blocks to keep the front jaws roughly parallel.

—Larry Humes, Everson, Wash.

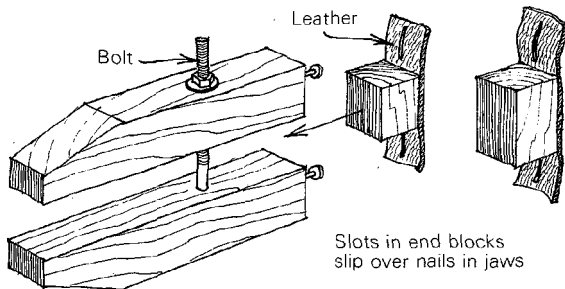

Quick-adjust picture-frame clamp-nut

To make this clamp-nut, tap a $\frac{3}{4}$ -in. section of $\frac{3}{4}$ -in. aluminum or steel rod. Then cut through the tapped hole on an angle with an end-mill cutter to clear the threads. Use a $1\frac{1}{64}$ -in. end-mill cutter for a $\frac{1}{4}$ -in. tap and a $2\frac{3}{64}$ -in. cutter for a $\frac{3}{8}$ -in. tap.

To use, tilt the nut on the threaded rod and slide into position for quick adjustment. Then straighten out the nut for fine adjustment and locking. The nut works well not only on picture-frame clamps but also in other locking-knob or quick-adjust situations.

—Walter W. Yaeger, Maple Shade, N.J.

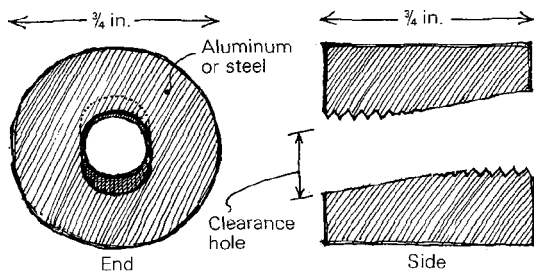

Gain two clamps

In exchange for a little ingenuity you can gain two large-capacity, versatile clamps: your drill press and lathe. Just clamp the work between quill and drill-press table or between headstock and tailstock (remove centers).

—Michael Baulsik, Paterson, N.J.

Spacing dadoes

Recently, while building a cabinet for cassette tapes, I experimented with several methods for spacing the numerous dadoes needed. Using an auxiliary miter-gauge fence gave the measure of accuracy and easy use I sought.

Bolt a piece of wood the length of the saw table and about 1 in. wide to the miter gauge. This auxiliary fence becomes an extension of the gauge, stabilizing long pieces of work and preventing twisting on the saw. The auxiliary fence should be the same thickness as the workpiece. After the dado width is

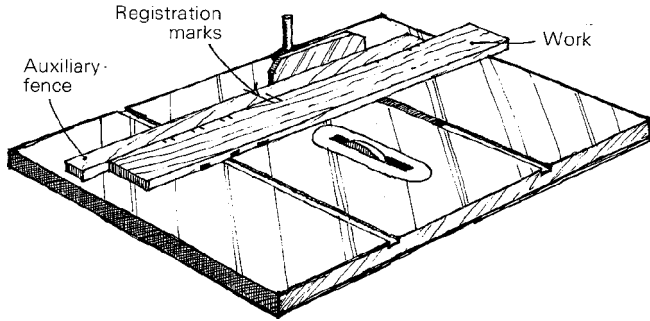

set and tested on scrap, make a cut into the auxiliary fence. Mark the right and left edges of the cut on the top of the fence. The workpiece, marked for spacing, is moved along the auxiliary fence. When the lines meet, slide the gauge into the dado blade, making the cut.

—Paul Saffron, Rockville Centre, N. Y.

EDITOR'S NOTE: A variation of Saffron's method is common practice in many cabinet shops. Screw a new auxiliary fence to the miter gauge and trim off the excess by pushing the fence through the saw. Since the end of the fence now coincides exactly with the saw kerf, it can be used for accurate cut-off work. Just slide the mark on die workpiece up to the end of the fence and push through the saw.

Turning lamp bases

Here are a couple of tricks to turn tall lamp bases. I don't have a large drill press; I drill the electric cord hole on the lathe with a homemade extended bit and a wooden guide block. To make the long bit, weld the turned-down shank of a $\frac{3}{8}$ -in. bit in a $\frac{1}{4}$ -in. hole drilled in the end of a 24-in. length

of $\frac{3}{8}$ -in. drill rod. Clean up the weld with a file and sandpaper. Make the guide block as shown in the sketch, screw the block to the stock over the center and carefully drill the cord hole. Back out the bit frequently to remove the chips. The guide block helps keep the hole right on line through the center of the stock.

To prepare the stock for turning, glue a short length of $\frac{3}{8}$ -in. dowel in the top end of the cord hole. Screw a faceplate to the other end of the stock, centering the faceplate over the hole. Now mount the stock in the lathe, centering the tailstock's cup center on the dowel insert. When the lamp base is done, remove the faceplate and drill out the dowel insert.

—Bob Kurz, Hartsville, S. C.

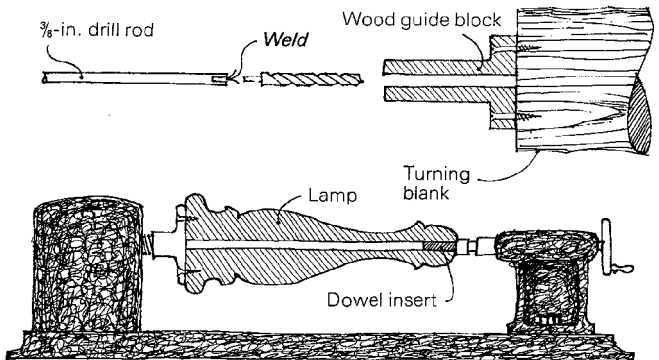

Duplicate turning gauge

This handy device is invaluable in turning duplicates. Used in multiples, it gives the correct position of control cuts and

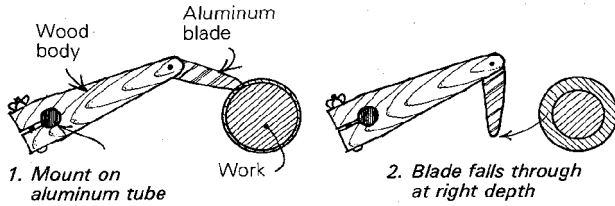

measures the depth as well. Several of the gauges—the number depends on the complexity of the work—are mounted on a metal tube or dowel fastened behind and level with the work. Select $\frac{1}{2}$ -in. hardwood for the gauge body and $\frac{1}{16}$ -in. aluminum for the blade. Drill one end of the body to fit the metal tube and slot the other end to fit the blade. The blade should fit loose in the slot and pivot easily on the pin. Set the position of the gauges by sliding along the tube. Then vary the angle of the body to set the depth. In use the blade will ride on the work (in the parting-tool cut) and fall through when the right depth is reached.

—Bayard Cole, Marietta, Ga.

Sanding block for lathe work

For years my woodworking students invariably burned their fingers sanding bowls and other lathe work. Then I hit upon the solution—sanding blocks cut from sheets of $\frac{1}{2}$ -in. thick rubbing felt. The felt sanding block shapes itself to shallow curves and can be deliberately shaped to match more elaborate forms.

Rubbing felt is available in 1-ft. squares from H. Behlen & Bros. (Box 698, Amsterdam, N.Y. 12010) and other suppliers. A similar material, used for typewriter cushions, is available

from office-machine suppliers. Cut the pad with a razor knife and rule. One block lasts indefinitely.

—Russell Anderson, Torrington, Conn.

Assembling staved cylinders

Here's a method based on the principle of canvas-backed tambours that simplifies the assembly of staved cylinders. Lay the staves side by side on a flat surface and carefully align the ends. Apply rows of tape (I use 2-in. wide plastic tape) to the outside surface. Turn the assembly over, apply glue to the stave edges and roll up the cylinder. Apply a strap clamp to complete the job.

—Pope Lawrence, Santa Fe, N. Mex.

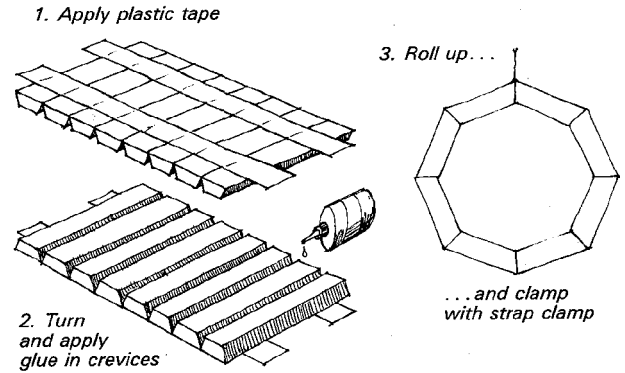

Methods of Work buys readers' tips, jigs and tricks. Send details, sketches (we'll redraw them) and photos to Methods, Fine Woodworking, Box 355, Newtown, Conn. 06470.

Methods of Work

Improved knife-sharpening fixture

When I tried to adapt James Gier's drill-press jointer-knife sharpening fixture (Methods, *FWW* #23, July '80) to the small knives in my 8-in. jointer, I ran into several problems. The biggest problem was positioning a row of thumbscrews of sufficient size to hold the narrow knife so they wouldn't interfere with the cupstone. To solve the problems I modified Gier's design as shown below.

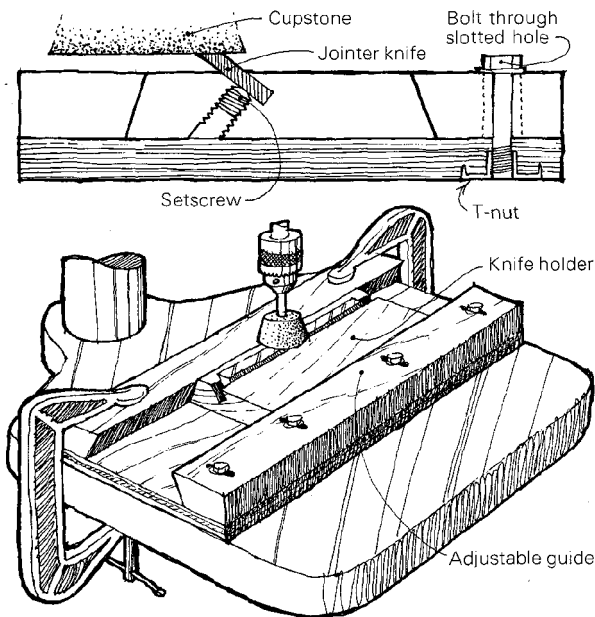

First I replaced the top-side thumbscrews with hex-head setscrews tightened from the bottom side of the sliding knife-holder block. Second, I beveled the edges of the block and the guide channel for a dovetail arrangement, so the block won't tip as it runs under the cupstone. I fastened the rear guide with bolts through slotted holes to T-nuts in the base, so the guide can be adjusted. If you want a really first-class fixture don't tap the wood. Rather use Rosann inserts (available from Constantine and others) to hold the setscrews.

As Gier suggests, take extremely light cuts and preserve the setting of the first knife with the quill-stop. Take light cuts with the second and third knives until you hit the stop depth.

—Tom E. Moore, Springfield, Va.

Making wooden checkers

Here's my method for making wooden checkers on the drill press. First grind the point off a 1½-in. spade bit. Only one side of the bit cuts, so grind it to the shape shown in the sketch (next column, top) and sharpen. Grind the other side of the bit back so it won't touch. Next, make a wooden jig with a ¼-in. deep, 2½-in. wide channel as shown. Install a ¼-in. dowel near one edge. Clamp the jig to the drill-press table, aligning the dowel with the centerline of the chuck.

Use 2½-in. wide, ⅞-in. thick material for the checker blank (I use walnut and maple). Drill ¼-in. registration holes along one edge of the checker blanks, making sure the holes are the same distance from the edge as the ¼-in. dowel is from the edge of the jig. Place the blank in the jig with a hole over the dowel. Set the drill press at its fastest speed and lower the bit ⅞ in. or so into the blank. You may have to experiment with depth to get the checkers to stack right. After shaping the top sides of all the checkers with the spade bit, use a fly cutter to cut almost through the blank. Grind another fly cutter so it

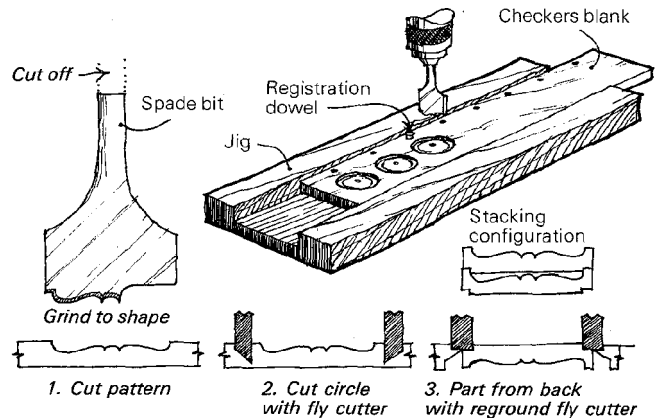

will cut square, turn the blanks over and part the checkers with a shoulder as shown above. The shoulder of one checker should mate with the shaped cavity in the top of another for stacking.
—Larry W. Brewer, Roanoke, Va.

A vise for end-drilling dowels

This vise, shown in the sketch below, makes easy the awkward operation of drilling holes in the ends of dowels on the drill press. The vise consists of a thick wood block and a frame. The sides of the block are keyed to and slide in U-shaped slots in the frame. The block tightens in the frame by means of a hanger bolt screwed into the tail of the block and run through an oversized hole in the frame, as shown in the detail. The vise's jaws clamp the work when you turn a wing nut against the end of the vise frame. A washer at this point helps.

To make the vise, use a 2-in. thick hardwood such as maple or birch. Plane the sides of the frame a little thinner than the center block. This allows the sides to move easily when the center block is clamped in position on the drill-press table.

I use the vise to drill the holes for new ends on broken chair legs and spindles. The four holes in the vise jaws are sized to fit common chair parts (⅜ in., ½ in., ¾ in., 1 in.). To drill the vise-jaw holes, clamp a piece of ⅞-in. scrap in the jaws and drill the four holes centered on the scrap. With the scrap removed, the holes will be undersized so that the 1-in. hole will grip a 1-in. dowel.

—Leo Myers, Wellington, Ohio

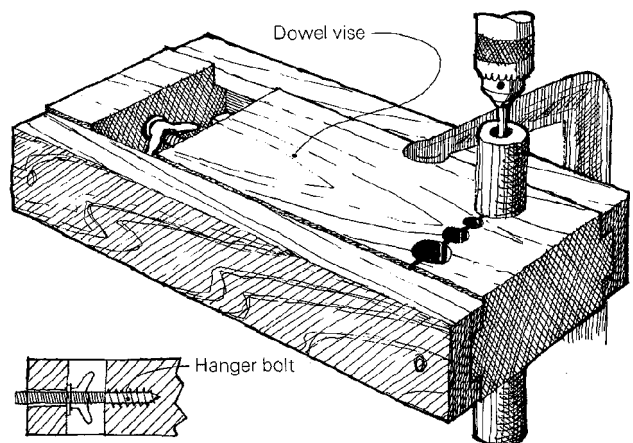

Removing broken screws

To remove a broken screw, drill a small hole in the shank. Insert a copper wire in the hole to conduct heat, then heat the wire with a torch until the wood around the screw bubbles and smokes a bit. Quickly tap a tapered, square punch into

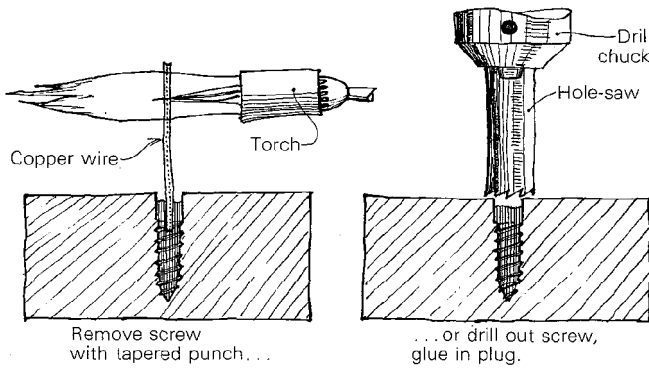

the hole and back *out* the screw. The heat liquefies resins in the wood and makes removal easier. Properly done, the procedure does not damage the hole, and another screw the same size may be used.

If the heat procedure doesn't work, drill out the broken screw with a tubular hole-saw just large enough to slip over the screw shank. Make the hole-saw by filing several coarse teeth in the end of a short section of thin steel tube. Drill out the broken screw, then glue in a plug to fill the hole.

—Jerry C. Blanchard, Carmel, Calif.

Cutting a dutchman

"Dutchman" is the name given to an irregularly shaped inlay that's used to repair a blemish (such as a cigarette burn) in woodwork. Typically the woodworker cuts the inlay first, traces its outline on the stock and cuts the shallow mortise to

fit. Here's an alternate approach that allows you to cut the mortise first or match an existing mortise. I'm sure the technique could be applied to marquetry work as well.

Lay a piece of paper over the mortise and shade the area around the mortise with the flat of a pencil (sketch, below). The edges of the mortise will stand out sharply. Tape the paper to the dutchman stock and transfer the pattern to the stock with a chisel and mallet. Remove the paper, cut out the dutchman and you should have a perfectly fitting inlay.

—Donald M. Stevens, Mansfield Center, Conn.

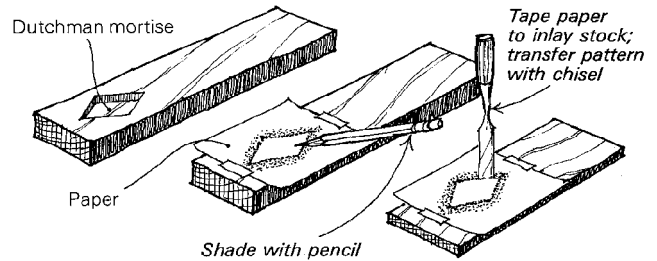

Greeno interlock joint

The development of a genuinely new wood joint is worthy of notice. In the shop of Jerry Green, the furniture maker with whom I apprenticed, we often worked with a tropical wood called partridge wood. Dramatic color made the wood popular, but it was prone to checking and honeycombing in thicker dimensions. Green's designs, nevertheless, frequently called for 2-in. and thicker material, so we laminated 3/4-in. stock. Capitalizing on this, Green invented this highly deco-

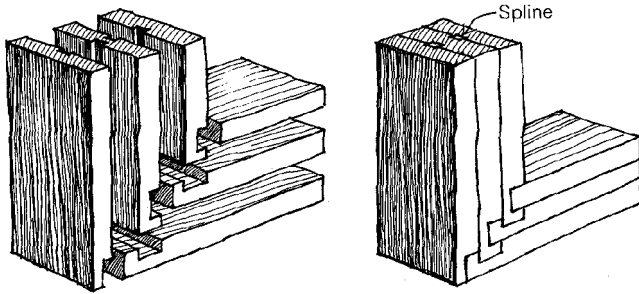

rative, extremely rigid and (since it requires only one setup) easy-to-machine joint. Because the joint is self-locking, it must be assembled while laminating. After the glue sets, scrape and belt-sand the surfaces. To register the laminated boards we often added splines, as shown in the sketch.

In memory of its inventor we came to call this joint the Greeno interlock joint.

—John W. Kreigshauser, Kansas City, Mo.

Cutting round tenons on slats

With a metal pipe, a simple jig and my radial-arm saw, I solved the problem of cutting round tenons on the ends of slats for the sides of a cradle. Find a 6-in. length of pipe that slips snugly over the slats (my slats are $\frac{3}{4}$ in. wide by $\frac{3}{8}$ in. thick). Add masking tape to the slats to tighten up the fit if they're loose. Build the simple jig shown in the sketch at right and clamp it and the stop block to the saw's fence. Carefully adjust the stop block so that the tenons will be the right length. Mount a sharp plywood blade in the saw and center

the blade over the slat location. Now push a slat into the pipe and place the pipe in the jig with the slat up against the stop. Lower the blade until it just touches the flat side of the slat (this will result in a slightly undersize $\frac{3}{8}$ -in. tenon). Rotate the pipe to cut a clean shoulder on the slat. Work the pipe back and forth under the blade, slowly rotating the pipe. A round tenon will result. This process leaves the tenon a little bit rough, but so much the better for gluing. After you're set up, you can cut the tenons on 20 or 30 slats in an hour.

—George Eckhart, Kenosha, Wis.

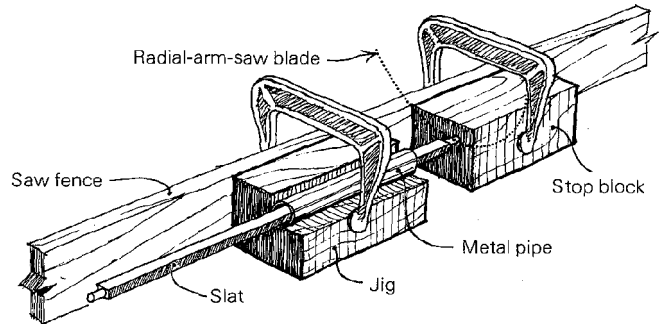

Chair-rung tenons on the bandsaw

Here is an easy method of using the bandsaw to make tenons on round pieces such as chair rungs. Take out the saw's miter gauge, put it in backwards (with the face toward you) and clamp it to the table with a C-clamp. Position the gauge so that its face is the same distance from the cutting edge as the depth of the desired shoulder on the tenon. Deep shoulders

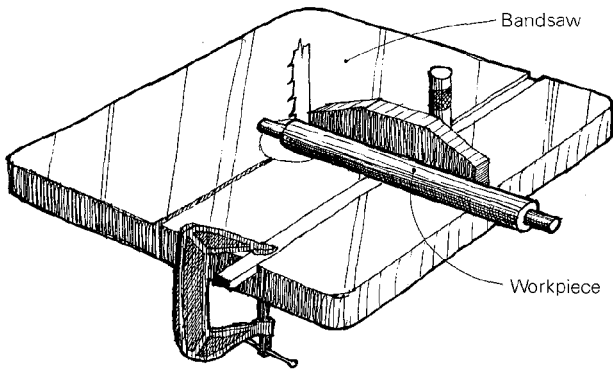

may require two or three passes. With the saw on, rotate the workpiece against the face of the miter gauge. Done properly, the result is a smooth, properly sized tenon.

— George Kramer, Santa Rosa, Calif.

Fluting jig

This jig routs accurate and consistent flutes on tapered turned legs. The jig is a U-shaped plywood channel as wide as your router base, mounted to the lathe bed. Dimensions will vary according to your router base and the peculiarities of your lathe bed. Attach two router-support strips to the inside of the jig with bolts and wing nuts through slotted holes so the strips can be angled parallel with the tapered leg.

To use the jig, first turn all legs to shape, then mount the jig to the lathe bed. Chuck one leg between centers, locking it into position with the index head. Now set the router-

support strips parallel with the turned workpiece. To do this, simply set a board (as wide as the interior of the jig) on the work and tighten the support strip's wing nuts with the strips resting on the board. Remove this adjustment board and fasten stops to the support strips so each flute will be the same length. Now you're ready to rout the flute. Use the holes in the lathe's indexing head for accurate spacing of the flutes around the leg.

— John Sanford, Camden, Maine

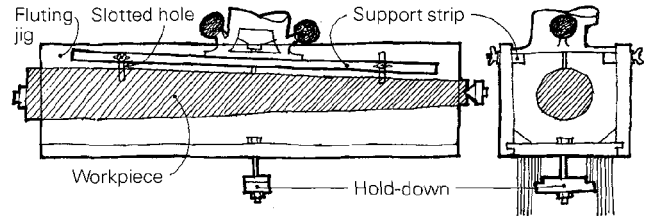

Cutting wooden threads

To cut perfect wooden threads, immerse the dowel in hot paraffin for ten minutes prior to threading. Thread while the dowel is still warm. The shavings roll out of the die in a neat string, leaving a perfect thread base. The method works even on hard-to-thread woods like oak.

— Al Grendahl, St. Paul, Minn.

Refinements on the roller support

The heart of my roller horse for supporting long stock off the table saw, radial saw or jointer is a worn-out typewriter platen. These are available, often just for the asking, from typewriter service shops, and they stay truer than wooden rol-

lers, an advantage particularly for jointer-feed support. The wedges between the roller carriage and the horse allow for fine height adjustment. —D. Kerman, Swampscott, Mass.

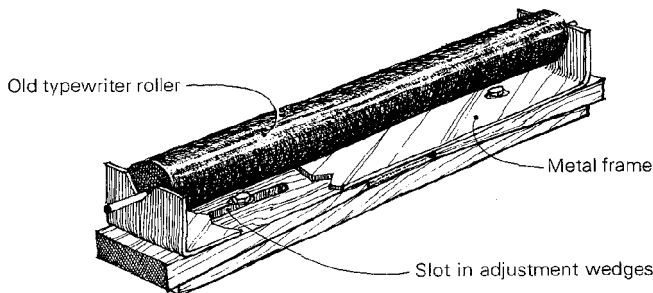

Glue spreaders

For years I had trouble spreading just the right amount of glue on the edge of boards. Fingers are messy, brushes get hard and the glue bottle's applicator leaves blobs. Recently I discovered that a short, thin piece of scrap will even out the glue perfectly. The sticks work so well it's worth cutting a supply of the 5-in. long, 1/8-in. thick, 1/2-in. wide applicators to have on hand. —Jon Gulett, Washington, Ill.

The old familiar popsicle sticks work well for spreading glue. These inexpensive sticks are available in large quantities from craft stores or from restaurant suppliers as coffee stirrers.

—Larry Joseph, Alva, Okla.

The best tool I've found for applying glue is a small, flexible artist's palette knife.

—Phil Loomis, Enfield, N.H.

Chair-rung chuck

In the Southern Appalachian mountains we turn dowels and rungs from stock that's been riven with a froe, then cleaned up with a hatchet or drawknife. With the device sketched below, you can quickly chuck the rough stock in the lathe.

To make the chuck, screw a 1 1/2-in. thick hardwood block to a small faceplate. Turn the block to a 3-in. cylinder with a cone-shaped depression in the face, as shown in the sketch. Stop the lathe and with a V-parting chisel cut four 1/8-in. deep grooves in the walls of the cone 90° apart to grab the corners of square stock.

Prepare the stock to be turned by giving it four quick licks with a hatchet to cut a short, square section on one end. With the square end of the stock in the cone, tighten the lathe's tailstock on the other end and you're ready to turn.

—W.W. Kelly, Clinton, Tenn.

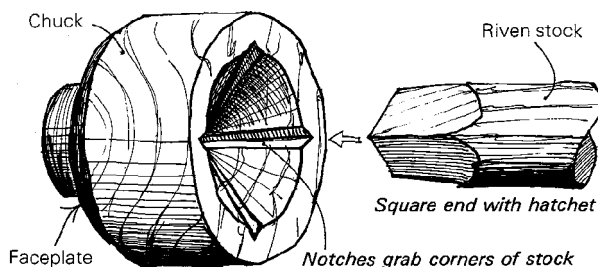

Methods of Work buys readers' tips, jigs and tricks. Send details, sketches (we'll redraw them) and photos to Methods, Fine Woodworking, Box 355, Newtown, Conn. 06470.

Methods of Work

Improved knife-sharpening fixture

When I tried to adapt James Gier's drill-press jointer-knife sharpening fixture (*Methods*, *FWW* #23, July '80) to the small knives in my 8-in. jointer, I ran into several problems. The biggest problem was positioning a row of thumbscrews of sufficient size to hold the narrow knife so they wouldn't interfere with the cupstone. To solve the problems I modified Gier's design as shown below.

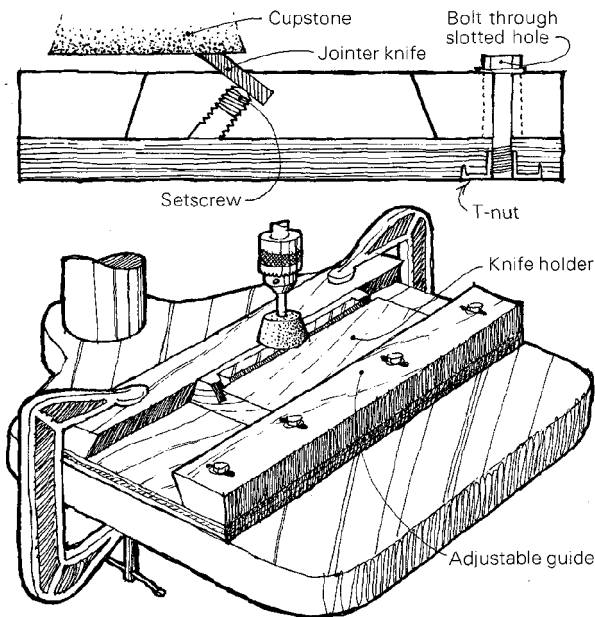

First I replaced the top-side thumbscrews with hex-head setscrews tightened from the bottom side of the sliding knife-holder block. Second, I beveled the edges of the block and the guide channel for a dovetail arrangement, so the block won't tip as it runs under the cupstone. I fastened the rear guide with bolts through slotted holes to T-nuts in the base, so the guide can be adjusted. If you want a really first-class fixture don't tap the wood. Rather use Rosann inserts (available from Constantine and others) to hold the setscrews.

As Gier suggests, take extremely light cuts and preserve the setting of the first knife with the quill-stop. Take light cuts with the second and third knives until you hit the stop depth.

—Tom E. Moore, Springfield, Va.

Making wooden checkers

Here's my method for making wooden checkers on the drill press. First grind the point off a 1½-in. spade bit. Only one side of the bit cuts, so grind it to the shape shown in the sketch (next column, top) and sharpen. Grind the other side of the bit back so it won't touch. Next, make a wooden jig with a ¼-in. deep, 2½-in. wide channel as shown. Install a ¼-in. dowel near one edge. Clamp the jig to the drill-press table, aligning the dowel with the centerline of the chuck.

Use 2½-in. wide, ⅞-in. thick material for the checker blank (I use walnut and maple). Drill ¼-in. registration holes along one edge of the checker blanks, making sure the holes are the same distance from the edge as the ¼-in. dowel is from the edge of the jig. Place the blank in the jig with a hole over the dowel. Set the drill press at its fastest speed and lower the bit ⅞ in. or so into the blank. You may have to experiment with depth to get the checkers to stack right. After shaping the top sides of all the checkers with the spade bit, use a fly cutter to cut almost through the blank. Grind another fly cutter so it

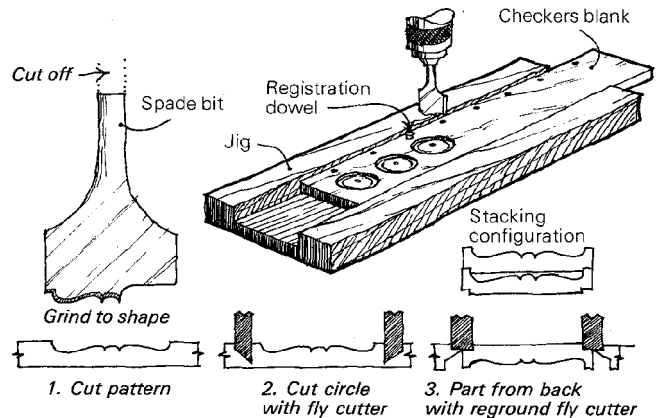

will cut square, turn the blanks over and part the checkers with a shoulder as shown above. The shoulder of one checker should mate with the shaped cavity in the top of another for stacking.
—Larry W. Brewer, Roanoke, Va.

A vise for end-drilling dowels

This vise, shown in the sketch below, makes easy the awkward operation of drilling holes in the ends of dowels on the drill press. The vise consists of a thick wood block and a frame. The sides of the block are keyed to and slide in U-shaped slots in the frame. The block tightens in the frame by means of a hanger bolt screwed into the tail of the block and run through an oversized hole in the frame, as shown in the detail. The vise's jaws clamp the work when you turn a wing nut against the end of the vise frame. A washer at this point helps.

To make the vise, use a 2-in. thick hardwood such as maple or birch. Plane the sides of the frame a little thinner than the center block. This allows the sides to move easily when the center block is clamped in position on the drill-press table.

I use the vise to drill the holes for new ends on broken chair legs and spindles. The four holes in the vise jaws are sized to fit common chair parts (⅜ in., ½ in., ¾ in., 1 in.). To drill the vise-jaw holes, clamp a piece of ⅞-in. scrap in the jaws and drill the four holes centered on the scrap. With the scrap removed, the holes will be undersized so that the 1-in. hole will grip a 1-in. dowel.

—Leo Myers, Wellington, Ohio

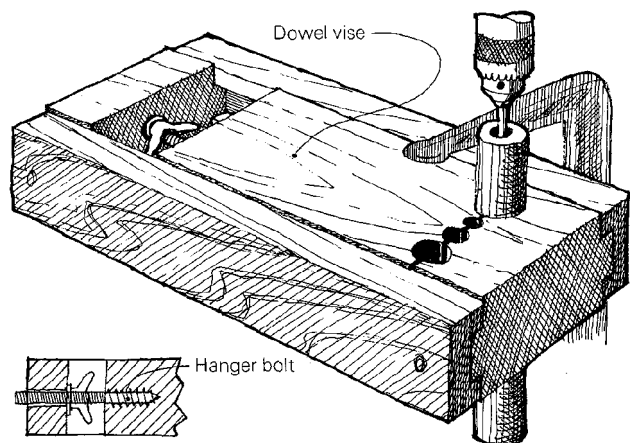

Removing broken screws

To remove a broken screw, drill a small hole in the shank. Insert a copper wire in the hole to conduct heat, then heat the wire with a torch until the wood around the screw bubbles and smokes a bit. Quickly tap a tapered, square punch into

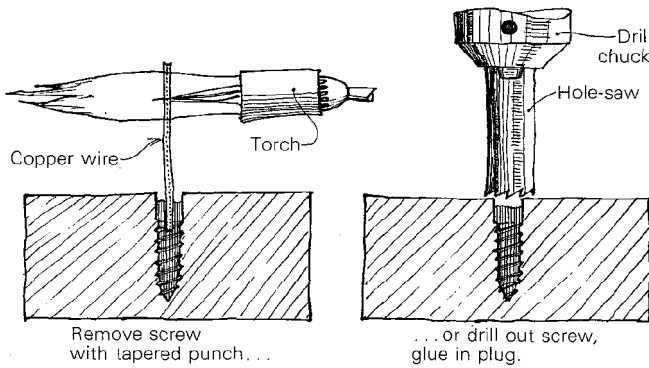

the hole and back *out* the screw. The heat liquefies resins in the wood and makes removal easier. Properly done, the procedure does not damage the hole, and another screw the same size may be used.

If the heat procedure doesn't work, drill out the broken screw with a tubular hole-saw just large enough to slip over the screw shank. Make the hole-saw by filing several coarse teeth in the end of a short section of thin steel tube. Drill out the broken screw, then glue in a plug to fill the hole.

—Jerry C. Blanchard, Carmel, Calif.

Cutting a dutchman

"Dutchman" is the name given to an irregularly shaped inlay that's used to repair a blemish (such as a cigarette burn) in woodwork. Typically the woodworker cuts the inlay first, traces its outline on the stock and cuts the shallow mortise to

fit. Here's an alternate approach that allows you to cut the mortise first or match an existing mortise. I'm sure the technique could be applied to marquetry work as well.

Lay a piece of paper over the mortise and shade the area around the mortise with the flat of a pencil (sketch, below). The edges of the mortise will stand out sharply. Tape the paper to the dutchman stock and transfer the pattern to the stock with a chisel and mallet. Remove the paper, cut out the dutchman and you should have a perfectly fitting inlay.

—Donald M. Stevens, Mansfield Center, Conn.

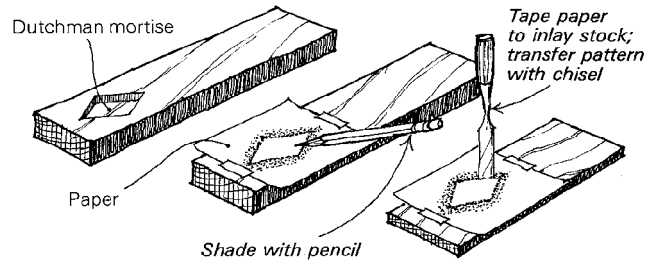

Greeno interlock joint

The development of a genuinely new wood joint is worthy of notice. In the shop of Jerry Green, the furniture maker with whom I apprenticed, we often worked with a tropical wood called partridge wood. Dramatic color made the wood popular, but it was prone to checking and honeycombing in thicker dimensions. Green's designs, nevertheless, frequently called for 2-in. and thicker material, so we laminated $\frac{3}{4}$ -in. stock. Capitalizing on this, Green invented this highly deco-

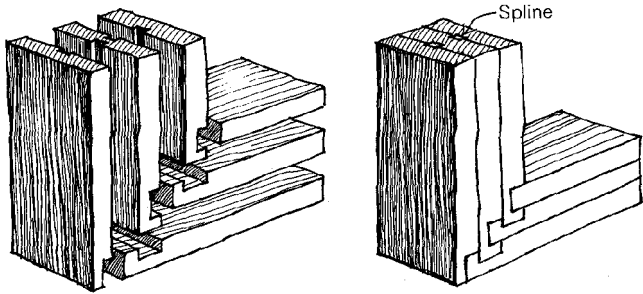

rative, extremely rigid and (since it requires only one setup) easy-to-machine joint. Because the joint is self-locking, it must be assembled while laminating. After the glue sets, scrape and belt-sand the surfaces. To register the laminated boards we often added splines, as shown in the sketch.

In memory of its inventor we came to call this joint the Greeno interlock joint.

—John W. Kreigshauser, Kansas City, Mo.

Cutting round tenons on slats

With a metal pipe, a simple jig and my radial-arm saw, I solved the problem of cutting round tenons on the ends of slats for the sides of a cradle. Find a 6-in. length of pipe that slips snugly over the slats (my slats are $\frac{3}{4}$ in. wide by $\frac{3}{8}$ in. thick). Add masking tape to the slats to tighten up the fit if they're loose. Build the simple jig shown in the sketch at right and clamp it and the stop block to the saw's fence. Carefully adjust the stop block so that the tenons will be the right length. Mount a sharp plywood blade in the saw and center

the blade over the slat location. Now push a slat into the pipe and place the pipe in the jig with the slat up against the stop. Lower the blade until it just touches the flat side of the slat (this will result in a slightly undersize $\frac{3}{8}$ -in. tenon). Rotate the pipe to cut a clean shoulder on the slat. Work the pipe back and forth under the blade, slowly rotating the pipe. A round tenon will result. This process leaves the tenon a little bit rough, but so much the better for gluing. After you're set up, you can cut the tenons on 20 or 30 slats in an hour.

—George Eckhart, Kenosha, Wis.

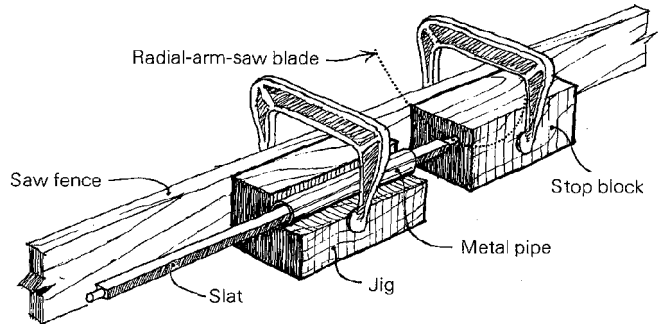

Chair-rung tenons on the bandsaw

Here is an easy method of using the bandsaw to make tenons on round pieces such as chair rungs. Take out the saw's miter gauge, put it in backwards (with the face toward you) and clamp it to the table with a C-clamp. Position the gauge so that its face is the same distance from the cutting edge as the depth of the desired shoulder on the tenon. Deep shoulders

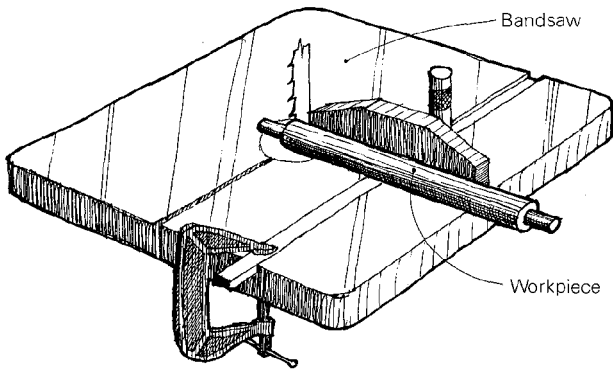

may require two or three passes. With the saw on, rotate the workpiece against the face of the miter gauge. Done properly, the result is a smooth, properly sized tenon.

— George Kramer, Santa Rosa, Calif.

Fluting jig

This jig routs accurate and consistent flutes on tapered turned legs. The jig is a U-shaped plywood channel as wide as your router base, mounted to the lathe bed. Dimensions will vary according to your router base and the peculiarities of your lathe bed. Attach two router-support strips to the inside of the jig with bolts and wing nuts through slotted holes so the strips can be angled parallel with the tapered leg.

To use the jig, first turn all legs to shape, then mount the jig to the lathe bed. Chuck one leg between centers, locking it into position with the index head. Now set the router-

support strips parallel with the turned workpiece. To do this, simply set a board (as wide as the interior of the jig) on the work and tighten the support strip's wing nuts with the strips resting on the board. Remove this adjustment board and fasten stops to the support strips so each flute will be the same length. Now you're ready to rout the flute. Use the holes in the lathe's indexing head for accurate spacing of the flutes around the leg.

— John Sanford, Camden, Maine

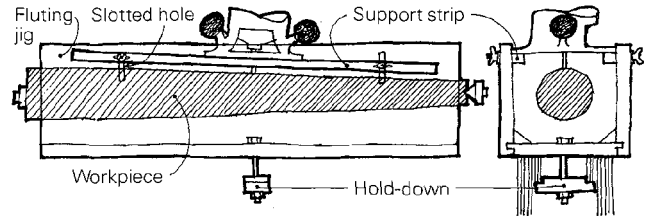

Cutting wooden threads

To cut perfect wooden threads, immerse the dowel in hot paraffin for ten minutes prior to threading. Thread while the dowel is still warm. The shavings roll out of the die in a neat string, leaving a perfect thread base. The method works even on hard-to-thread woods like oak.

— Al Grendahl, St. Paul, Minn.

Refinements on the roller support

The heart of my roller horse for supporting long stock off the table saw, radial saw or jointer is a worn-out typewriter platen. These are available, often just for the asking, from typewriter service shops, and they stay truer than wooden rol-

lers, an advantage particularly for jointer-feed support. The wedges between the roller carriage and the horse allow for fine height adjustment. —D. Kerman, Swampscott, Mass.

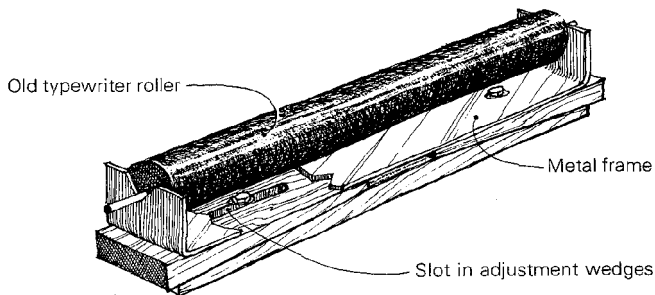

Glue spreaders

For years I had trouble spreading just the right amount of glue on the edge of boards. Fingers are messy, brushes get hard and the glue bottle's applicator leaves blobs. Recently I discovered that a short, thin piece of scrap will even out the glue perfectly. The sticks work so well it's worth cutting a supply of the 5-in. long, 1/8-in. thick, 1/2-in. wide applicators to have on hand. —Jon Gulett, Washington, Ill.

The old familiar popsicle sticks work well for spreading glue. These inexpensive sticks are available in large quantities from craft stores or from restaurant suppliers as coffee stirrers.

—Larry Joseph, Alva, Okla.

The best tool I've found for applying glue is a small, flexible artist's palette knife.

—Phil Loomis, Enfield, N.H.

Chair-rung chuck

In the Southern Appalachian mountains we turn dowels and rungs from stock that's been riven with a froe, then cleaned up with a hatchet or drawknife. With the device sketched below, you can quickly chuck the rough stock in the lathe.

To make the chuck, screw a 1 1/2-in. thick hardwood block to a small faceplate. Turn the block to a 3-in. cylinder with a cone-shaped depression in the face, as shown in the sketch. Stop the lathe and with a V-parting chisel cut four 1/8-in. deep grooves in the walls of the cone 90° apart to grab the corners of square stock.

Prepare the stock to be turned by giving it four quick licks with a hatchet to cut a short, square section on one end. With the square end of the stock in the cone, tighten the lathe's tailstock on the other end and you're ready to turn.

—W.W. Kelly, Clinton, Tenn.

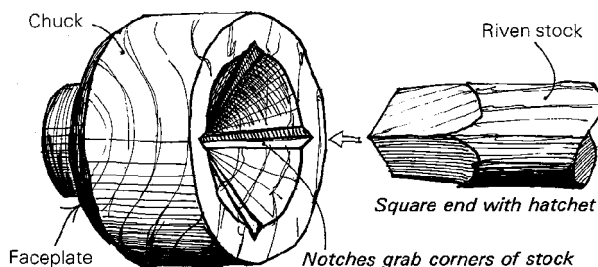

Methods of Work buys readers' tips, jigs and tricks. Send details, sketches (we'll redraw them) and photos to Methods, Fine Woodworking, Box 355, Newtown, Conn. 06470.

Methods of Work

Two steady-rests

The homemade stabilizer device shown below allows me to turn four-poster beds and architectural columns on my 9-ft. lathe. The stabilizer eliminates the whipping and vibrating that accompany long-stock turning. The brace bolts to the lathe bed at about the midway point. A long upward-pointing handle is hinged to move the cast-aluminum stabilizer back and forth so it can ride against the stock. The stabilizer has several different diameters to fit different-sized turnings. The aluminum, coated with a little beeswax where it rubs, effectively carries away the heat. The brace adjusts against the stock through a spring-loaded device that moves an old file against a stack of hacksaw blades.

—Deloe Brock, Chattanooga, Tenn.

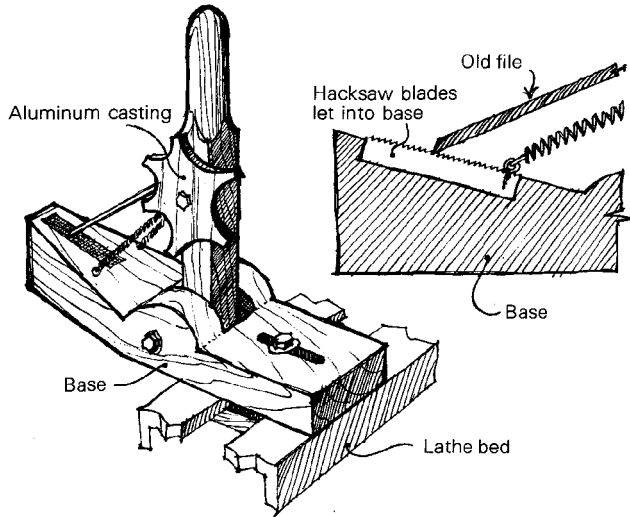

Here is an economical steady-rest made from three sections of 2x4, a carriage bolt and two plastic casters (drawing, below). Cut and join the wood to fit your lathe bed, then drill the bolt hole the same height as the center spindle. The base clamps to the lathe bed and adjusts in or out for large or small work. The roller arm pivots on the bolt to provide a fine-tune adjustment to the changing diameter of the work in progress.

—James Ulwelling, Coon Rapids, Minn.

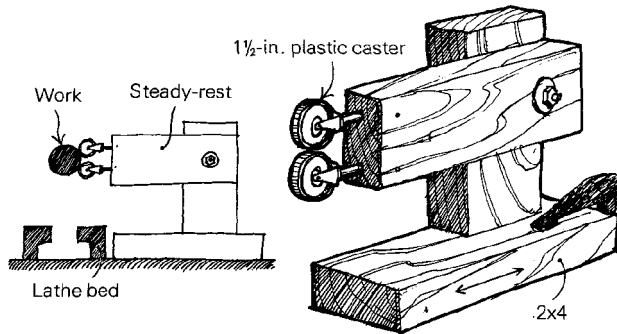

Modifying twist drills for wood

A worn-out twist drill can be modified to perform much better in wood. First grind the tip flat. Then, using a cone-shaped stone in a hobby grinder or the rounded-over corner of an abrasive wheel, grind two hollows—one on each side of the center. The hollows form a center spur and two outer spurs. Be sure to bevel the hollows so that the back side of the flutes will clear the wood.

In use, the center spur holds the bit stable and keeps it

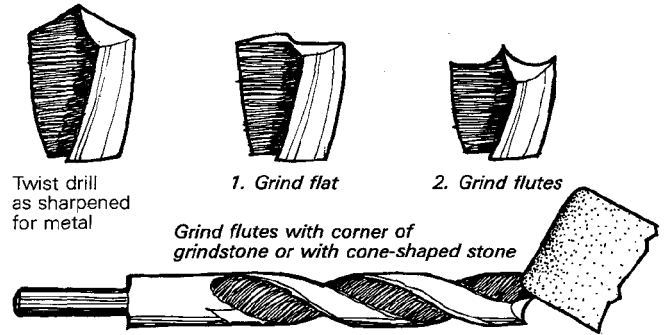

from wandering. The outer spurs cut the wood's fibers in advance of the cutting edge to give straight, clean holes.

—Stanley F. Kayes, Richmond, Va.

Expanding-action bracelet mandrel

Here is an effective mandrel for turning the outside contours of bracelets. You'll need an arbor (made for using buffing and grinding wheels on the lathe), a rubber stopper and a small piece of 1/4-in. thick plywood. Turn the rubber stopper to a 1/16-in. thick, 2 3/8-in. wide disc. This diameter works well for bracelets, which usually range from 2 3/8 in. to 2 3/4 in. in inside diameter. Turn also two 1/4-in. plywood discs—one to a diameter of 3 in., the other to 2 1/2 in. Assemble the mandrel with the arbor's steel washers to the outside and the rubber disc sandwiched between the plywood discs as shown.

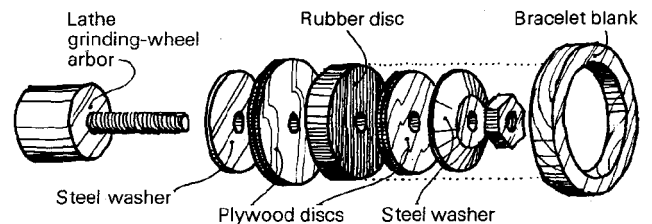

To use the mandrel, cut the inside of the bracelet blank with a circle cutter, bandsaw the outside to rough shape and slip the blank over the rubber disc. Now tighten the nut. The rubber will expand uniformly to exert enough pressure to hold the bracelet. Turn one side of the outside contour, then reverse the blank and turn the other face.

This method could be adapted to napkin rings and other ring-shaped objects by sizing the rubber and plywood discs to the project.

—Max M. Kline, Saluda, N.C.

Drafting a smooth curve

Several years ago a Danish carpenter showed me this method of drawing a smooth curve to fit a given width and height. Start by driving three nails, one at the top and one at each end of the space where you will construct the curve. Now tack two sticks together—one parallel to the base and the other

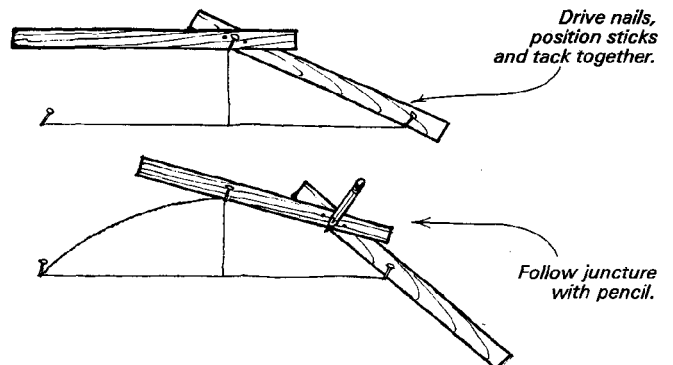

riding two of the nails: the one at the top and one at one edge. Put a pencil at the juncture of the sticks and let the sticks slide over the nails as you mark the curve. Repeat the same procedure on the other side to complete the curve.

—Thomas Baird, Woodland, Calif.

Straightening curved lumber

Here's a trick for straightening a bowed board. Tape a piece of angle iron to the concave edge of the board to serve as a guide, as shown below. If the board is thin, block up the angle iron so it won't drag on the table. Pass the board through the saw with the flat edge of the angle iron against the rip fence. Remove the iron, flip the board and pass through the saw again. The result is a straight board with parallel sides.

—Charles F. Riordan, Dansville, N.Y.

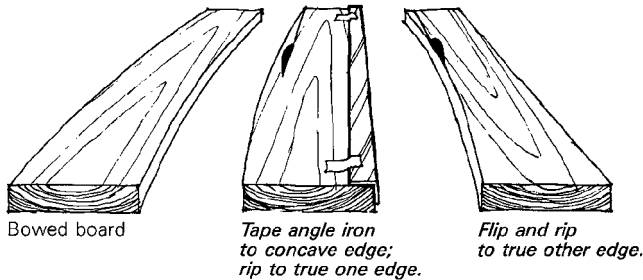

Shopsmith work tray

This handy work tray, designed to use with the Shopsmith, rests on the tool's tubular ways. It holds lathe tools, work arbors, sandpaper or small workpieces. You can drill holes in

the tray for the Shopsmith's allen wrench, drill bits, plug cutters or whatever

Materials and tray size can vary. My tray (drawing, below) is about 18 in long, 12 in wide and 1 in thick. Semicircular cutouts on the tray's supports let the tray ride the Shopsmith's tubular ways. The supports are spaced so that if the tray is turned 90°, the supports straddle the ways.

—Billy Hill, Orange Park, Fla

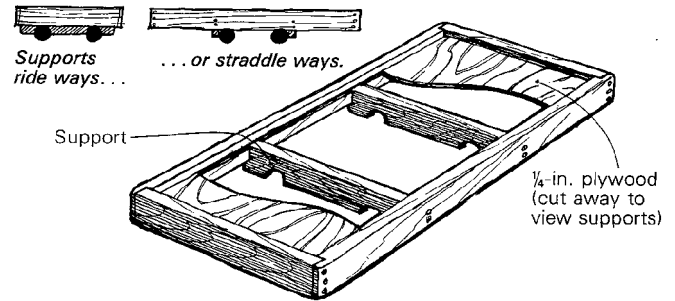

Sanding small pieces in the clothes dryer

Here's an alternative to Charles Reed's method of sanding the corners off small pieces of wood (*FWW* #23, July '80). My method does not even require a frame.

I needed radiused edges on both ends of a thousand 1/2-in. long pieces of 1/2-in. diameter dowels. I lined the insides of three 5-lb. plastic peanut-butter buckets with 100-grit sandpaper, tossed in about 350 dowels per bucket and secured the lids with masking tape. Then I put the buckets into my clothes dryer along with a couple of heavy towels to aid the

tumbling action. I set the dryer to air fluff and turned it on. In only ten minutes the job was done.

To protect your dryer, be sure to use only "soft" containers, secure the lid, add towels and use a no-heat setting.

—Marilyn Warrington, Tiro, Ohio

Adjustable miter-gauge stop

Here is a jig that's easy and fast to make and to use. It's basically a stick with a dowel through it, clamped to the table-saw miter gauge to give precise production-run cutoffs. It works at any angle.

—Alan Miller, Lakewood, Colo.

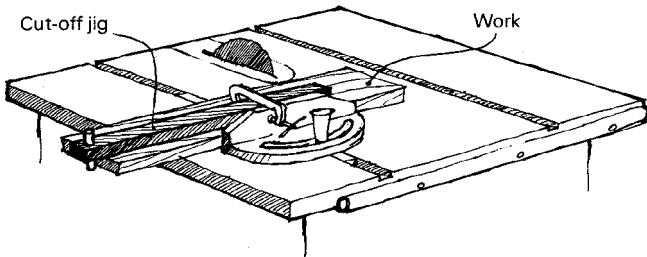

Horizontal vise

This horizontal vise, installed on a workbench, is indispensable for sanding, routing, carving and planing. For many operations it holds the work better than bench dogs. The vise consists of three simple parts: a bench screw, an oak jaw and a wooden step-block. Mount the bench screw's nut to the bench from the bottom so that the surface will be flat if you remove the vise. Cut the 2-in. thick jaw about 20 in. or so

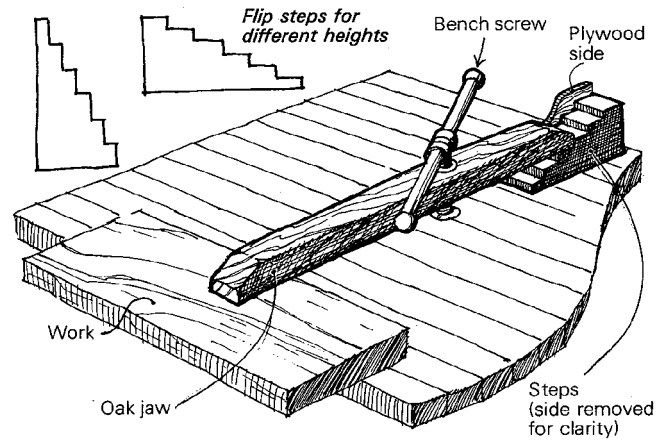

long. Drill an oversize hole in the jaw about 7-in. from the back and fasten the bench screw through the hole. Bandsaw the step-block from a 4x4. Cut the steps taller one way than the other so you can flip the block and use it both ways. To keep the back end of the jaw from slipping off the sides of the step-block, glue a piece of plywood to each side.

—Pendleton Tompkins, San Mateo, Calif.

Safe jointer hold-down

A few years ago, after nipping a finger in a jointer, I became preoccupied with the safe operation of this machine. I pored through textbooks and catalogs searching for a hold-down/guard device that would be safe, easy to construct and inex-

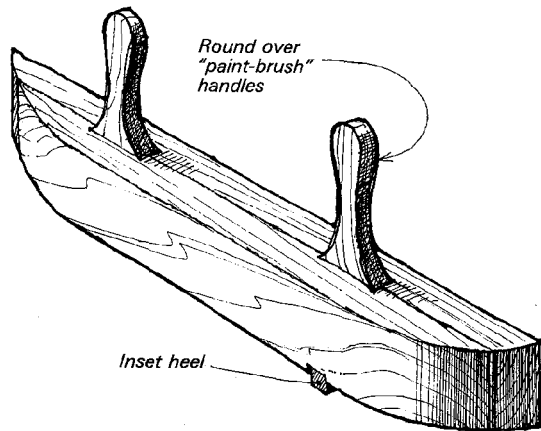

pensive. I looked for a design that would protect both hands, be rigid, provide firm, steady pressure and allow good control of the workpiece. Finding nothing meeting my requirements, I eventually came up with the design shown above.

I keep three different lengths of hold-downs (24-in., 48-in., and 78-in.) to accommodate various lengths of lumber. Dimensions, however, are not critical and you should adapt them to your needs. Start with two lengths of 2x4. Dress the inner faces and cut dadoes into them to accept the "paint-brush" handles. Mate the dadoes and glue up. After the glue has set, square up the piece and cut the dado into the base to accept the 3/4-in. heel so it protrudes about 1/2 in. Now band-saw the curves in the leading and trailing ends of the unit and sand smooth. These curves allow the jointer's blade guard to

open and close with a minimum of blade exposure.

Next set the heel and the handles. If possible wedge the 3/4-in. square heel in place rather than gluing it. It may have to be replaced from time to time. Cut the heel and the handle bases a trifle short so they won't protrude and snag on the jointer fence or the workpiece. The hold-down is now ready for very safe surfacing work.

—Bernard Maas, Cambridge Springs, Pa.

Clamping segmented turning blanks

Worm-screw hose clamps make good, inexpensive gluing clamps for segmented turning blanks or other cylindrical gluing jobs. The clamps are available in hardware and automotive supply stores in sizes up to 6 in. in diameter. For larger diameters simply screw two clamps together head-to-tail, or cut the band and install steel wire to extend the clamp's circumference. Marks and dents can be avoided by placing cardboard or wooden pads between the clamp and the work.

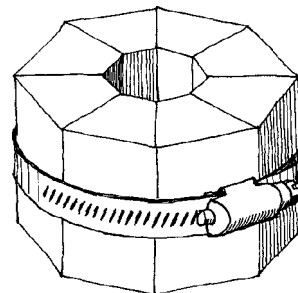

— W. L. Chess, Washington, Conn.

Cutting wide panels

A simple wooden strip tacked to the bottom of the workpiece will let you rip panels that are too wide for the rip fence on your table saw. Size the wooden strip to run in the miter-

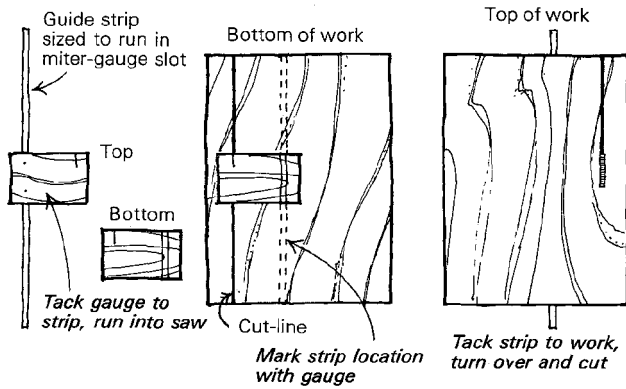

gauge slot (generally $\frac{3}{4}$ in. by $\frac{3}{8}$ in.), and cut it slightly longer than the cut to be made. To lay out the strip's location on the workpiece, I used a small piece of $\frac{1}{8}$ -in. thick birch plywood as a distance gauge. Tack the plywood to the strip, then run the assembly into the saw for about an inch. Turn the assembly over and mark on the plywood the strip's location with a pencil line on both sides of the strip. Remove the plywood and you have a gauge that shows the exact relation of table slot to saw kerf.

To use the strip, draw an accurate cut-line on the back of the work. Now use the distance gauge to lay out the strip location, and brad the strip to the bottom of the work. Remember to position the strip so that the saw kerf is to the waste side of the cut-line. Turn the assembly over, feed the strip into the table slot and make the cut. If you have done the layout carefully, the cut will be right on. I use a thin-rim ply-

wood blade, which, since the finished side of the work is up, produces a smooth, clean cut.

The procedure is not practical for the first cut on a 4x8 sheet of plywood or for quantity cutting. But it works fine for those 30-in. and 36-in. panels that are so awkward to cut on a small saw.

— William Langdon, Lake Forest, Ill.

Reversible jig for the radial-arm saw

This reversible jig is useful when you need to cut a number of identical pieces with angled dados on opposite sides. The two dowels and the saw fence locate the work. Two stops clamped to the fence define the width of the dado. Once you have cut all pieces on their top sides, flip the jig end-for-end, push the dowels through to the opposite side of the jig, relocate the stops and proceed to cut the bottom dados.

— J.A. Hildebeitel, S. Burlington, Vt.

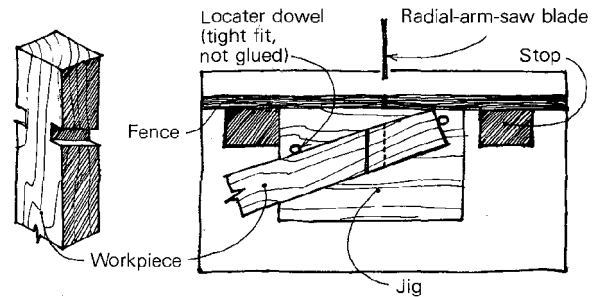

Methods of Work buys readers' tips, jigs and tricks. Send details, sketches (we'll redraw them) and photos to Methods, Fine Woodworking, Box 355, Newtown, Conn. 06470.

Methods of Work

Dadoing guide

Sketched below is a quick setup I use for repeated dadoing operations with my router and portable workbench/visé. It's so simple, yet it's more accurate and quicker to use than the fence-clamped-to-the-board approach. Make the parts from stock the same thickness as the boards you're dadoing. Clamp the fence atop two guide blocks to form a bridge over the work as shown. Shim the fence off the two guides with cardboard or veneer. This should leave enough clearance so the stock will slide in under the fence easily. Now just push the workpiece in under the bridge, snug against the stop. Clamp the workpiece to the workbench somewhere behind the fence, set the router to proper depth and go to town. The guide blocks not only guide the workpiece, they also support the router base near the edge of the board.

—Josh Markel, Philadelphia, Pa.

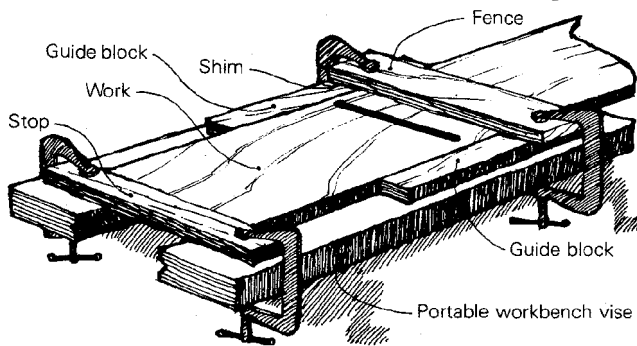

Cutting corner bridle joints

This procedure eliminates the tedious fence adjustments and frustrating $\frac{1}{32}$ -in. errors that go with cutting open mortise-and-tenon joints on the table saw. It is based on a thin auxiliary fence or shim that's exactly as thick as the saw kerf of the blade you're using. The shim stock, made of thin plywood (door skin) or surfaced from solid stock, should be as wide as your fence is tall, and should be long enough to clamp to your fence—say 8 in. by 16 in.

To use, set up the saw to cut the open mortise. Saw the mortise as usual by passing both cheeks of the stock over the blade. Do not adjust the fence to saw the tenon. Simply clamp the shim to the fence and saw out the tenon—first one face then the other. The shim repositions the tenon stock just to the other side of the cut line. The joint will be just right.

—John F. Anderson, Bottineau, N.D.
and Ivan Hentschel, Kingston, N.J.

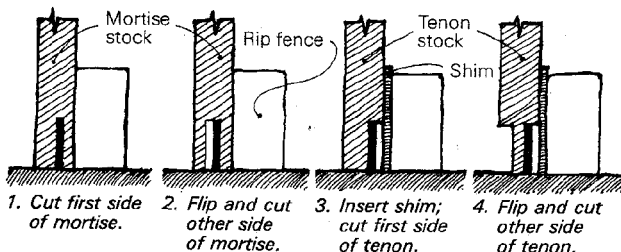

Easy stretcher joint

One of the easiest stretcher-to-post joints (used on European workbenches and machinery stands) is to butt-join the parts using two bolts engaging captured nuts. The simple joint eliminates the precision fitting required with mortise and tenon. In fact, with this joint, bolt holes should be bored oversize to accommodate adjustments or inaccuracy. Twin bolts keep the joint tight and the members perpendicular,

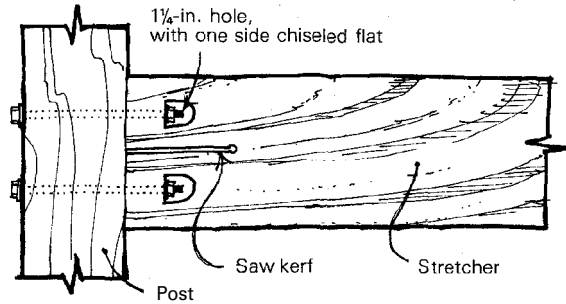

but there's a problem: The wide stretcher is restrained cross grain against the post, making it prone to splitting.

Here's a solution to the problem: Pre-split the end of the stretcher by sawing a kerf down the middle of the stretcher for 3 in. or 4 in. The split is an adaptation of twin tenons. The slot allows the wood to move across its width, relieving the stresses from changes in humidity. Drill a hole through the stretcher at the end of the slot so that splitting forces are distributed around the circumference of the hole rather than focused at one point.

—Richard Starr, Thetford Center, Vt.

Improved leg-vise adjustment

On all the leg vises I've seen, to change the jaw opening you have to wiggle a pin out of a hole near the floor and fiddle it back into the next hole. Here's a design with fixed pins you can work with your foot—just step on the adjustment foot and it disengages, then kick the bottom of the moving jaw to where you want it.

The trick is to make the adjustment foot not out of wood but out of $\frac{1}{4}$ -in. aluminum plate scavenged or from a sheet-metal dealer. To make the slots, drill a series of holes in the plate and saw into them from the edge with a hacksaw or a bandsaw. You can saw most aluminum alloys on the bandsaw with regular wood-cutting blades. Aluminum tends to grab drill bits, so clamp the adjustment foot down before you begin drilling.

—Geraldo Bennuccio, Oakland, Calif.

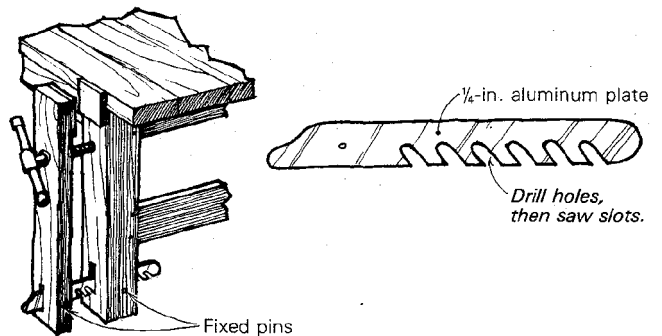

Check-free drying for green bowls

If you hesitate to turn bowls or other lathe projects from green log slices because of the checks and cracks that develop as the wood dries, here's a cure that is effective, free, uses no chemicals and requires no kiln. The secret is to bury your project in wood chips while it dries. During the rough turning of the bowl I accumulate a fair amount of green wood chips. I add chips left over from previous projects—all the chips I can find. I dump the chips in a box and bury my bowls in them, leaving at least a couple of inches of chips around all sides. I bury the bowl again after each work session and, after the project is completed, I leave it in the chips for a month. That's it. Sound too simple? Apparently the chips absorb the moisture from the green workpiece without letting it dry too

fast. I have used this procedure with a large number of projects using several species of wood without a single failure.

— William Wisniewski, Albion, Pa.

Drill-press mortising fixture

Here's a fixture for cutting mortises on the drill press using fluted end-milling cutters. A lateral control mechanism, made from $\frac{1}{8}$ -in. steel plate, pivots at three points and gives the fixture the back-and-forth movement needed to cut the mortise. The stop mechanism is a $\frac{1}{4}$ -in. rod that passes through a collar piece that is screwed to the base. Two sliding collars, fastened in place on the rod with setscrews, limit the movement of the sliding table. To use, clamp the fixture to the drill-press table. Clamp the work to the fence and set the stop collars for the size mortise needed. Your right hand, on the drill-press feed, controls the depth of the mortise, while your left hand controls the lateral movement for the length of the mortise.

—Mario Rodriguez, Brooklyn, N. Y.

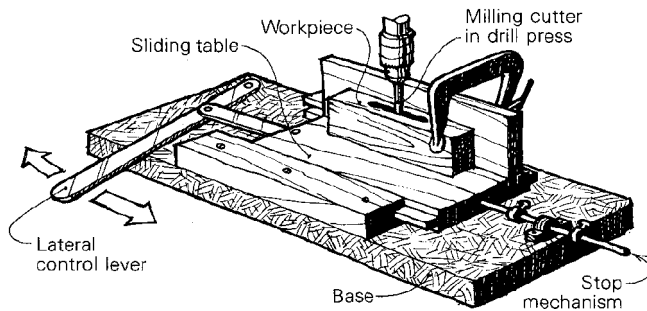

Hazardless honing

Here is a simple combination storage box and jig that will enable you to use your oilstones more effectively and safely. What makes the box unique is a wide tongue cut into the bottom. In use, the tongue is secured in a woodworking vise, ensuring a stable, firm foundation for the oilstone.

To make the box, cut blocks for the base and cover from any hardwood. Use a drill press with a multispur or Forstner bit to remove most of the waste. The cavity in the base should be about half as deep as the stone. The cavity in the cover should be $\frac{1}{16}$ in. or so deeper to provide clearance. Chop out the remaining waste with a chisel, making sure the stone fits snug in the base and doesn't rock. To complete the box, saw away the bottom corners of the base to leave the tongue.

—Al Ching, Fullerton, Calif.

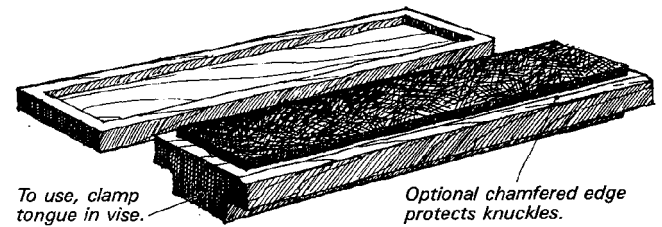

Enhanced table-saw miter gauge

For five years I have looked unsuccessfully for a 10-in. table saw with a "rolling table" facility for crosscuts and miters. The one I'm familiar with is a big, old Oliver. The new Rockwell and Powermatic sliding table attachments are similar in concept and are fine if you have \$2,000 to spend on the

saw and rig. They take up room on the left of the saw and are really designed for the large stock requirements of a cabinet shop. There are plywood jigs that sit atop the saw and serve the purpose, but I've found them to be inaccurate. My solution is simple, inexpensive and as effective as the expensive attachments if you are not cutting whole sheets of plywood.

Simply take your miter gauge apart and insert a piece of Formica between the miter-gauge bar and the protractor fence. Cut the Formica the same size as the left half of the table and fasten the smooth side down. When using the fixture you can press down on the piece of wood being crosscut without causing the wood to bind as it slides on the table. The Formica spreads the pressure over a wider area. The addition of a backboard faced with abrasive paper practically eliminates creep.

—Michael J. Hanley, Cedarburg, Wis.

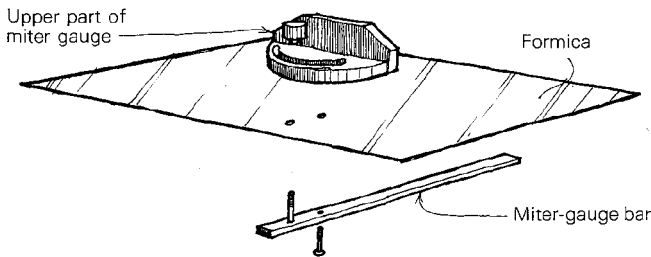

Crosscutting wide panels

Here is an accurate and simple way to crosscut plywood panels or boards that are too wide to cut using the saw's miter gauge. Start with a straight 1x2 longer than the panel is wide. Clamp the 1x2 underneath the panel so that it becomes a fence that

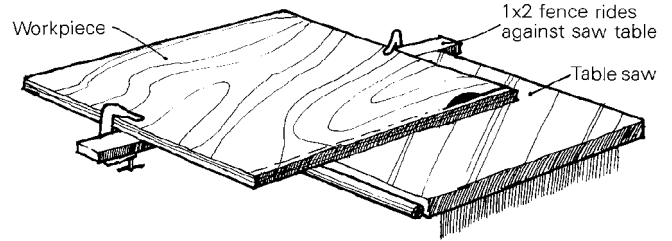

runs against the saw table's edge. Carefully measure and position the fence using a framing square. Then clamp the new fence to the panel with C-clamps. The method can be adapted to ripping plywood and wall paneling by lengthening the fence. By clamping the fence to wide panels at an angle, you can make miter cuts that are virtually impossible any other way.

—Steve DeLay, Hollister, Calif.

Auto-finishing tips adapted to wood

My shop is next door to an auto paint-and-body shop. Through the association I have been able to adapt several of their methods and products to wood finishing. It seems that the technology of auto-finish suppliers is steps ahead of their wood-industry counterparts. Certainly their marketing is.

First, I use naphtha (VM&P brand) as a wetting agent for rubbing down intermediate finish coats with wet/dry sandpaper. Naphtha's advantage is that unlike oils or water, it evaporates quickly and cleanly. You can remove the sanding scum with steel wool, wipe with a naphtha-dampened rag, and the surface is clean and dry, ready for the next coat.

Second, two DuPont auto-finish products, the 3679 re-

tarder and the 3602S acrylic lacquer thinner, work very well used with nitrocellulose and acrylic modified wood lacquers. Add the 3679 in small amounts to a cheaper utility thinner to upgrade it for use in finish-coat mixtures. The 3602S is a good damp-weather blush retarder and warm-weather thinner.

Third, I have adapted the auto shop's mist coat to produce a superior finish. After a piece has had its last finish coat and it has "flashed" or surface-dried (5 to 10 minutes) I recoat with a wet coat of one part lacquer to four parts thinner. This procedure seems to eliminate any overspray and overspray dust. It adds greatly to the surface uniformity. Little if any rubbing will be needed to produce a fine finish.

—Steve Ulrich, Kingsville, Tex.

Cutting circles on the bandsaw

The circle-cutting jig I use in my shop offers several advantages over other circle-cutting jigs published in Methods of Work. First, because the jig uses the miter-gauge slot in the saw's table, no clamps are necessary. This not only saves time but also guarantees perfect size duplication even if the jig is removed from the saw. Second, since the jig's base stays in a fixed position relative to the blade, you can put marks on the base to calibrate circle sizes. Third, you can reverse the sliding-dovetail center guide to cut large circles. And last, an adjustable stop can easily be added on the front of the jig so it can be used with a variety of blades. The stop ensures that cutting always takes place at the true tangent of the circle.

To use, set the center guide to the desired radius, lock it in place with the setscrew and place the circle blank on the center pin. If the blank cannot have a center hole in it, then cut a dummy disc from plywood and secure the blank to the

dummy disc with double-sided tape. With the jig's rail riding in the saw's miter-gauge slot, ease the jig straight into the blade until the stop contacts the front of the saw table. Then turn the blank until the circle is completed.

Although you can make the jig from solid stock, it is easier to make the dovetail slot if you laminate the base. My jig (shown below) is made of acrylic plastic, which is threaded for the two thumbscrews. If you use wood, let in square nuts for the thumbscrews and secure them with epoxy.

—Thomas G. Marston, Mill Creek, W. Va.

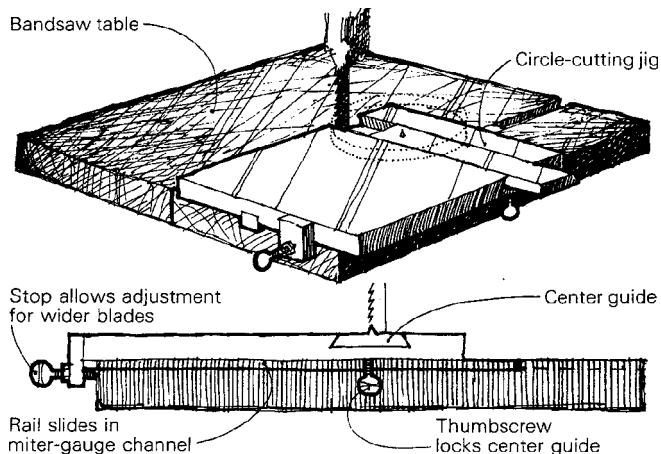

Folding saw-dolly

I have to share my shop space with an automobile and other "foreign objects" so from time to time I have to move my

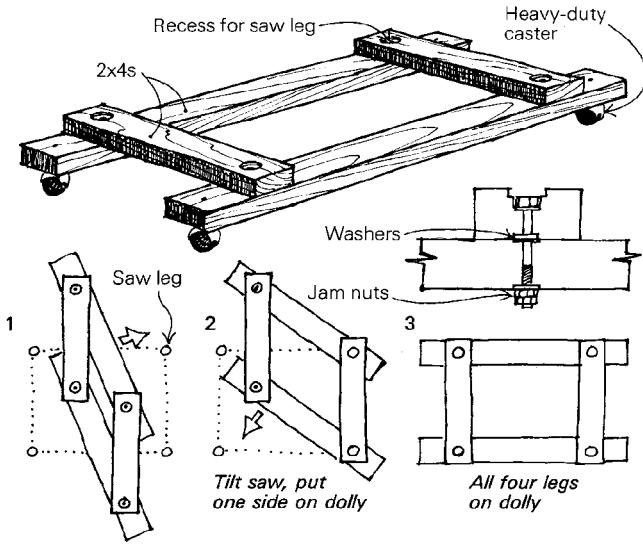

table saw, which is on a four-legged, sheet-metal stand. To avoid having to drag the saw across the floor, I made a dolly that collapses like a pantograph. The folding action allows me to load the saw on the dolly one side at a time as shown in the sequence above. —Robert E. Warren, Camarillo, Calif.

Cutting Plexiglas

You can quickly and easily cut Plexiglas with these two tools. To make the scribing table, start with a sturdy bench and add two lengths of angle iron for a vise as shown in the sketch. Set

the bottom angle iron into the bench so it's flush with the bench top. Weld two short sections of 1/8-in. threaded rod to the bottom iron so you can tighten the top iron on the Plexiglas with wing nuts. The scribing tool is a piece of hacksaw blade fit to a handle and ground as shown.

To cut the Plexiglas, tighten it in place on the scribing table. Then drag the scribing tool across the Plexiglas using the top iron as a guide. The tool should produce a thin, continuous curl on each pass. After several passes, whack the projecting Plexiglas with your hand. It will break clean and square. —Jay Wallace, Ashland, Ore.

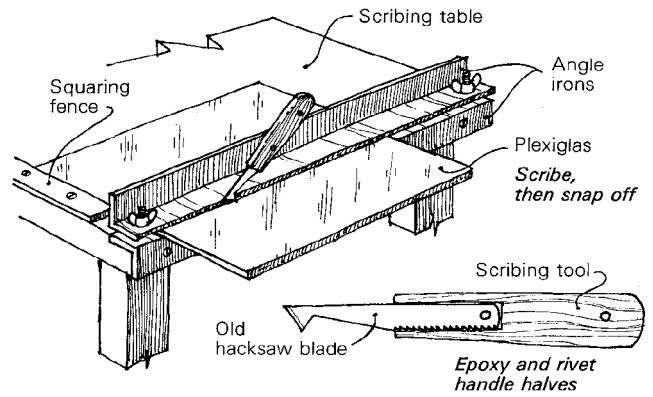

Methods of Work buys readers' tips, jigs and tricks. Send details, sketches (we'll redraw them) and photos to Methods, Fine Woodworking, Box 355, Newtown, Conn. 06470.

Methods of Work

Sharpening jointer knives—two ways

Here's how I sharpen jointer or thickness-planer knives on the table saw. Mount a 6-in. medium-grit emery wheel on the saw's arbor. Then clamp a straight-edged guide board across the table in front of the wheel. Fit the knife in a block that has been grooved along one edge. Be sure the groove is uniformly deep and parallel to the opposite edge of the block, and that the knife is firmly seated at the bottom of the groove.

Adjust the height of the emery wheel to touch the center of the knife's bevel. Keeping the block flat against the table, pass the knife slowly back and forth across the wheel. Take the lightest of cuts. Duplicate this on the other knives. Slowly raise the wheel until each knife is ground to a feather edge. Honing the knives on an oilstone completes the sharpening.

—Charlie K. Thorne, San Luis Obispo, Calif.

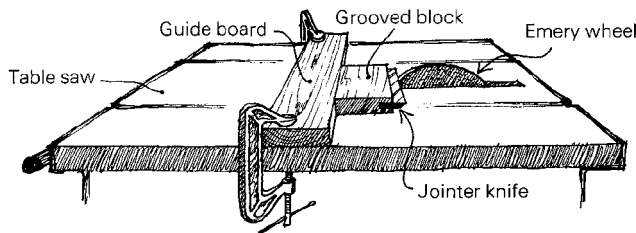

I sharpen jointer and planer knives on the table saw using the miter gauge. The approach offers several advantages: The knife edges are stronger (because they're straight-ground rather than hollow-ground), the grinding angle adjusts easily and the fixture handles long knives (up to 24 in.).

To make the fixture, drill and tap two holes in the slide of your miter gauge and fasten the plywood base of the fixture to the slide with machine screws. Now screw the top part of the fixture to the base so that the blade is sandwiched and clamped snugly in place. Install two adjuster bolts from the back edge of the fixture into nuts that have been mortised and epoxied into the base. Turn these bolts to adjust the first knife into perfect position. The bolts provide a reference for the last two knives so they will be ground exactly like the first.

—Jack Down, Maseru, Lesotho

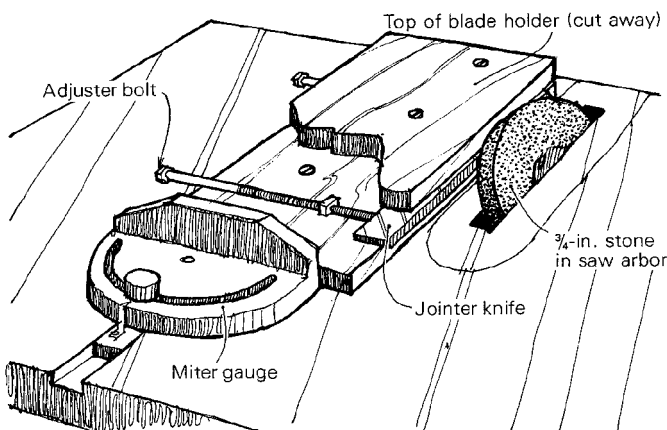

Eccentric router base

This router subbase allows me to rout an "in-between" size groove (for various stock thicknesses) without moving the guide fence or changing the setup. Because the subbase is eccentric to the router bit you can change the diameter of the base simply by changing the point of the base that rides against the guide fence.

To make the base, choose plywood, plastic or a 4-ply stack of

plastic laminate for the material. You can cut the eccentric shape on a bandsaw or jigsaw, but for a smoother, more accurate base use a router table to machine the base. First drill a 1/16-in. pivot hole at the center of the blank for the base and another 1/16-in. pivot hole offset from the center. The offset determines the eccentricity of the base. I used an offset of 1/8 in. which allows me to cut grooves of up to 1/2-in. with a 1/4-in. bit. On a line through these holes drill a 1/4-in. hole at a radius slightly larger than the radius of your router base. Before proceeding, it's a good idea to locate and drill the mounting holes in the subbase.

To cut the circumference of the base, mount the blank on the router table with the 1/4-in. hole over a 1/4-in. router bit.

Drill 1/16-in. holes into the router table through both the center pivot and offset pivot. Put a pin in the center hole, turn on the router and rotate the subbase 180°. Return the blank to its starting position, put the pin in the offset hole and rotate the base 180° in the other direction. You will have to finish the "step" area with a file. Before routing out the center of the subbase, you should pivot the base on the center hole and scribe measurement lines on the base for every 1/32 in. of diameter change. Use a fine-tip waterproof pen.

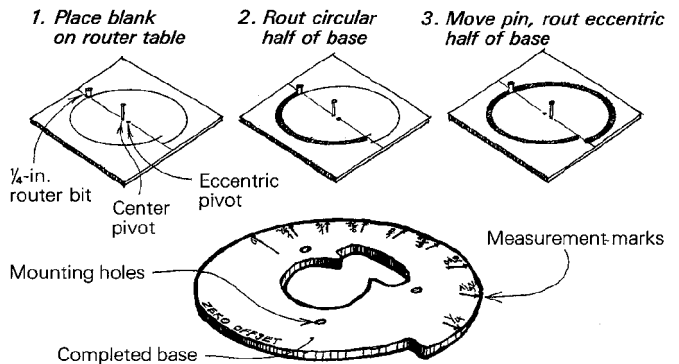

To use the base to cut a 3/16-in. groove, for example, clamp a guide fence in place on the work and rout a 1/4-in. groove. Keep the zero-offset part of the subbase against the fence. Now rotate the base until the 3/16-in. scribe line touches the fence. Keep the 1/16-in. mark touching the fence and make another pass, taking care not to twist the router. The result is a 3/16-in. groove.

—Mike Ramey, Seattle, Wash.

Plastic collars for bench dogs

This round bench-dog design is the simplest I've seen and yet provides additional benefits. Make the dog by slipping a short length of transparent plastic laboratory tubing over one end of a 1/2-in. or 3/4-in. dowel. If the tubing is the right size, it will hold tight without glue. If loose, fasten the collar to the dowel with rubber cement. The compliant plastic adjusts to non-parallel edges and firmly grips odd-shaped pieces. It won't mar even soft woods, and if damaged by an errant chisel (which emerges unnicked from the encounter), the collar is easily replaced.

—Thomas K. Dykstra, Rochester, N. Y.

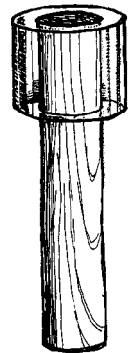

Shake shingles for dollhouses

To make realistic shake shingles for dollhouses, I constructed a guillotine splitter using a plane iron attached to a wood fixture. The fixture consists of a vertical board screwed to a horizontal base. Loose round-head wood screws guide the plane iron and hold it in place. The end-grain shingle stock feeds

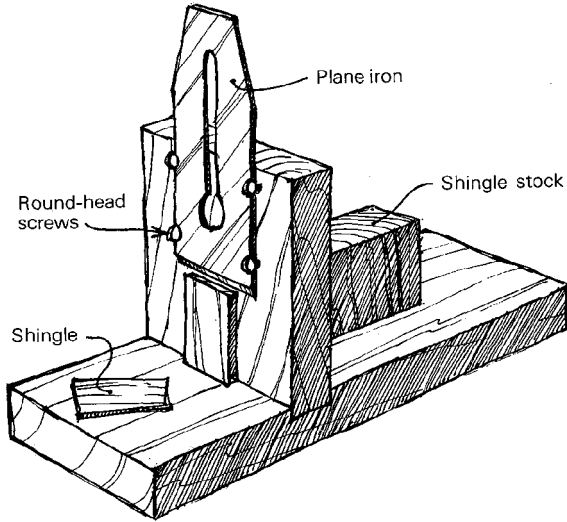

through a notch in the vertical board. One sharp tap from a mallet will produce a perfect miniature shake shingle.

— Gene Balzer, Flagstaff, Ariz.

Making toy wheels

Hardwood wheels for toys are expensive, not well sanded and do not come in many varieties of wood. I tried making my own, but the work was prohibitively time-consuming until I came up with the modified screw center I now use. With it I can turn out a wheel every four minutes on production runs.

I started with a standard morse-taper screw center (Sears)

that I modified in two ways. First, I drilled and tapped the tail of the screw center to accept a 1/4-in. drawbolt which holds the tapered shaft tight from the back of the headstock through the spindle. The drawbolt is simply a length of threaded rod with a washer and wing nut. The second modification was to remove the screw center. This leaves a 1/4-20 threaded hole for attaching the work.

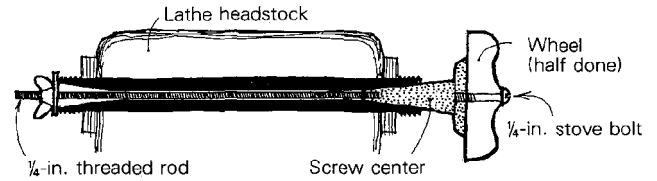

I cut the wheel blanks from scrap using a hole saw with a 1/4-in. pilot bit. Then I mount a blank on the modified center with an ordinary stove bolt. It takes about a minute to shape and sand each side. I try to completely finish one side before I turn the wheel around. While shaping, make sure the hub area is slightly thicker than the wheel rim for clearance.

For axles on the toys, I use 1/4-in. stove bolts screwed into a hidden nut mortised and epoxied in the vehicle's side. This is stronger and longer-lasting than wooden axles and allows the owner to take apart the toy and put it back together.

— George Pilling, Springville, Calif.

Installing glass for easy replacement

This method for securing glass in mitered frames makes it easy to replace the glass if it's ever broken. The key to the method is a special molding that fits in a groove cut into the frame. First

cut a rabbet in the inside edge of the frame stock. Then cut a groove in the frame stock offset from the rabbet's shoulder by the thickness of the glass. Next mill the molding with a tongue that slips into the groove with a snug fit. Assemble the frame and molding as shown in the sketch with two pieces on the bottom. If you have cut and fit the pieces carefully you won't need any brads or glue to lock the molding in place.

—Douglas L. Wahl, Washingtonville, N. Y.

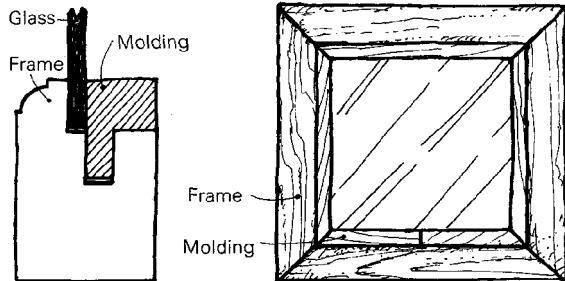

Routed box joint

I enjoyed Patrick Warner's article on the box joint (*FWW*#14, Jan. '79). I like the visual results, strength and ease of assembly the joint allows. Like Warner, I use a router to cut box joints, but my technique is different. I have installed a guide block on the base of my router that acts as a jig for accurately spacing the finger cuts. The setup does not limit me in width, angle or length of project. I have made jigs to fit several common-size router bits but I usually prefer the 1/2-in. setup for most work. The sketch shows how to mount the guide block for 1/2-in. cuts. The accuracy of the joint depends on how

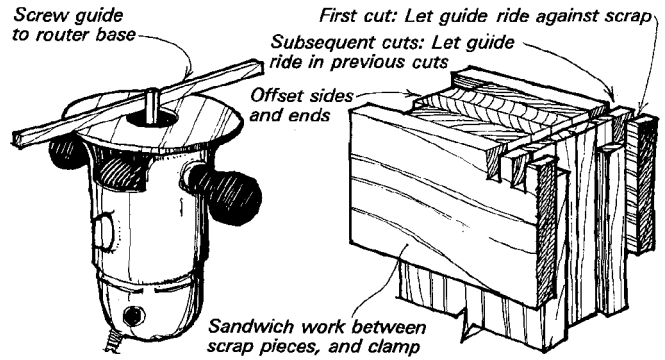

carefully you position the guide in relation to the bit. Drill the screw holes in the router base a little large to give yourself some adjustment room.

To use the guide, sandwich the box sides and ends between two pieces of scrap, offsetting the sides from the ends 1/2 in. and the ends from the scrap 1/2 in., as shown. Now chuck a carbide bit in the router and make the first cut with the guide sliding against the scrap pieces. For the second cut, just slide the guide in the newly cut groove. Continue the process across the ends of the boards for the rest of the cuts. It's like climbing a ladder. Wax the guide to slide easily in the grooves.

—George Persson, Star Lake, N.Y.

Shop-made counterbore

Here is an easily made counterbore for bolt heads, nuts and washers. With it you can avoid the problem of centering a second bit over a previously drilled bolt hole. Make the tool from



a length of steel rod the same size as your bolt stock. Find a flat washer that just slips on the rod, saw a slot in it and twist the washer apart slightly. Weld the washer to the rod about 1 in. from one end with the lower edge of the split facing clockwise. File the pilot end of the rod for proper clearance and sharpen the cutting edge of the washer with a file.

—Carl Meinzinger, Guemes Island, Wash.

Recycling old blades as scrapers

An excellent cabinet scraper can be made from a section of a 1-in. or wider bandsaw blade. Just cut the blade to 9-in. lengths, grind off the teeth and round the ends to get the shape you need. Because the blade flexes you can scrape hard-to-finish surfaces like handrails and cabriole legs.

—John E. Freimuth III, Peoria, Ill.

I recycle 12-in. power hacksaw blades as scrapers. When you grind the teeth off the blade, the resulting scalloped edge (from the wavy set) can be used for fast, rough stock removal. Reserve the other edge for finish work.

—Girvan P. Milligan, Carmel, N.Y.

Carver's stand

Woodcarvers will find this carver's stand useful—especially for sculpture and figures in-the-round. An old bowling ball at the heart of the stand forms what is, in essence, a universal

joint. The carver can rotate his work or incline it at any angle, thus permitting easy access to all areas of the carving. Hardware consists of a long lag bolt mounted through the bowling ball into the work and two 24-in. long, ½-in. threaded steel rods. When the carver has his work in the desired position, he simply tightens nuts on the threaded rods to lock the bowling ball in position and also to make the stand rigid.

—M.B. Hansen, Huntsville, Texas

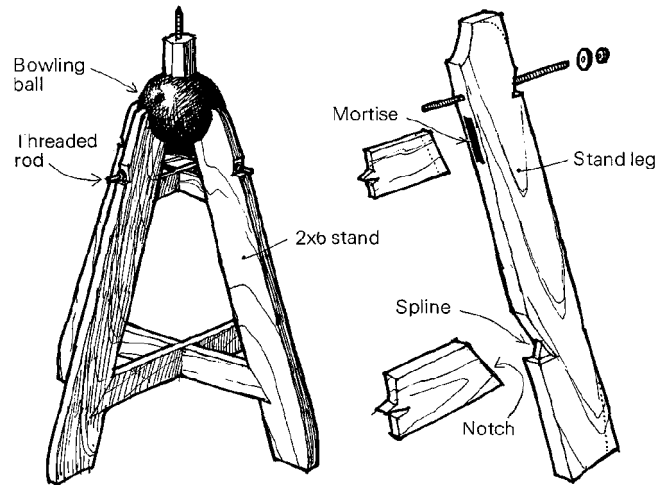

Methods of Work buys readers' tips, jigs and tricks. Send details, sketches (we'll redraw them) and photos to Methods, Fine Woodworking, Box 355, Newtown, Conn. 06470.

Methods of Work

Making dowels with the table saw

I prefer to make my own dowels for several good reasons. I can make any size dowel in any length from any wood. My system is simpler and certainly less expensive than the commercial dowel-making tools that are limited to only a few sizes. The drawings show the complete tooling required: a hardwood block and your table saw. The block size isn't critical, but it should be thick enough to clamp easily to the saw's rip fence and long enough to cover the sawblade in use. This last point is important because you'll need to reach across the saw to withdraw the finished dowel.

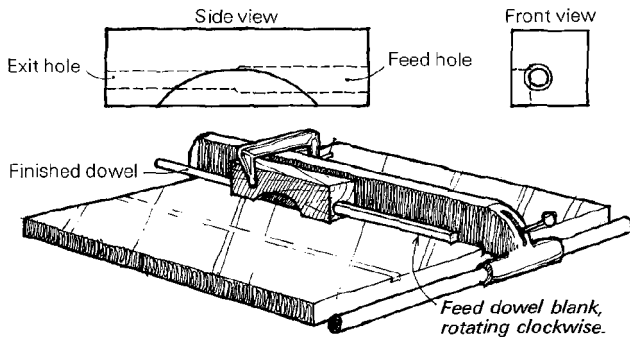

To construct the fixture, first drill a dowel-sized exit hole through the length of the block. Enlarge this hole from the front, halfway through the block, to produce a feed hole. The diameter of the feed hole should be the same as the diagonal of the square dowel blanks you plan to use. As a guide the diameter of the feed hole shouldn't exceed the exit hole by $\frac{1}{4}$ in. Now clamp the block to the saw's rip fence. Center the block over the blade. In a succession of cove cuts (made by raising the sawblade into the block) cut a channel from the edge to just into the wall of the exit hole. The best blade to use to channel the block and make dowels is a heavy, small-diameter carbide-toothed blade. Next rip the dowel blanks so they will turn easily in the feed hole. With the block clamped and the fence locked, start the saw and insert the blank. Rotate the blank clockwise and feed slowly until the blade starts cutting. Adjust the block's position with the rip fence until the dowel fits snugly in the exit hole. It's a good idea to withdraw the dowel and check the size of the first few inches.

In smaller sizes, which are difficult to rotate by hand, I cut a short dowel on one end. Then I chuck the short dowel in my portable drill. A slow feed and a slow rotation yield the smoothest dowels.

—Larry Churchill, Mayville, Wis.

Making dowels with the router

Here's how to make dowels of any size with a simple router setup. First drill a pilot hole through a 2x4 the same diameter as the dowel you want to produce. Chuck a core-box bit in your router, rout a recess in the front of the 2x4 just above the hole and clamp the router in position. Center the bit

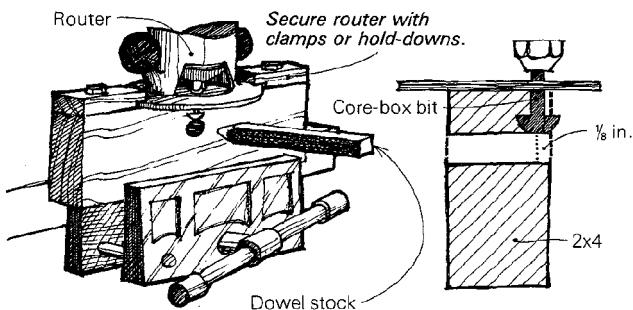

right over the top of the hole with the shaft of the bit inset about $\frac{1}{8}$ in. into the 2x4. Make sure the leading edge of the bit is precisely at the circumference of the hole. Now turn on the router and push the dowel blank into the hole, rotating the blank with a hand drill. Taper the front of the blank for easier starting.

—G. Weldon Friesen, Middlebury, Ind.

Adjustable drill-press fence

This drill-press fence is quickly adjustable for boring holes the same distance from an edge or for routing with the drill press. The base is plywood; the fence is hardwood and adjusts using wing nuts and an arc-shaped slot in the base. The sketch shows the details.

—Pendleton Tompkins, San Mateo, Calif.

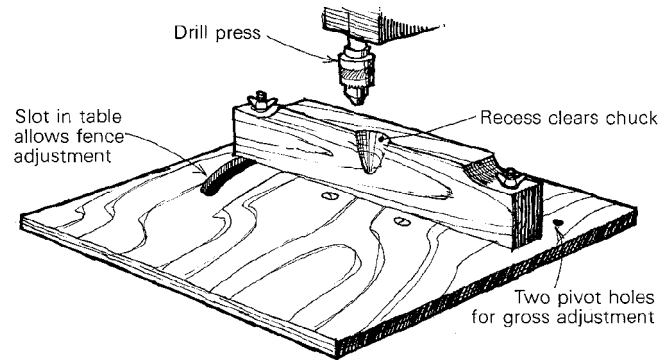

Three-member lap joint

Here's a variation of the lap joint I discovered while trying to find a way to connect three stretchers on a three-legged table. The joint is attractive and strong. Each member overlaps the other two members with a large edge-grain glue surface.

To lay out the joint scribe a centerline on both faces and both edges of all pieces. Set a bevel gauge to 60° and use it to mark the diagonal lines shown in the sketch. Saw away what waste you can, then finish chopping out the waste with a chisel. Take care to keep the glue surfaces flat and the edges that show crisp.

By changing the angle of the layout you can adapt this joint to any number of members, odd or even.

—David Nebenzahl, Flagstaff, Ariz.

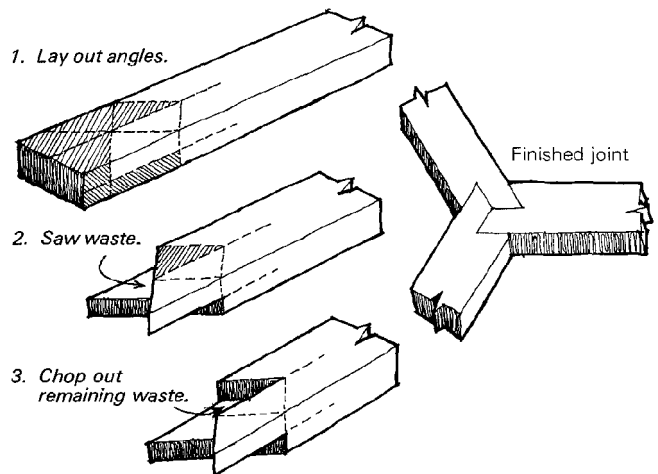

Bandsawn drawer bottom

By carefully bandsawing the center section from a solid-wood drawer at an angle, you can use a slice of the interior plug for the drawer bottom. If you intend to use the top face of the plug for a prescribed thickness of drawer bottom, carefully

determine the cut angle using mathematics, a scale cross-section drawing or trial-and-error test-cuts on a piece of scrap. The proper angle varies depending on the thickness of the drawer blank, the thickness of the desired bottom and the width of the bandsaw blade's kerf. The method will not work with drawer shapes that reverse direction, as shown below.

—J.A. Hildebeitel, S. Burlington, Vt.

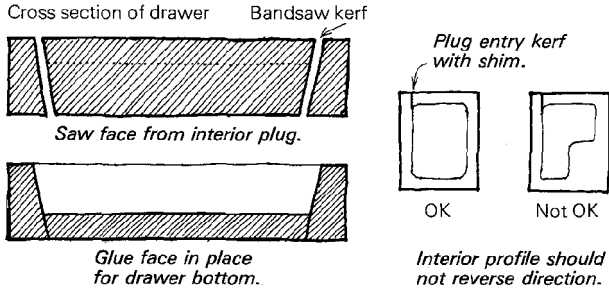

Glue-up rack

This inexpensive glue-up rack keeps edge-glued stock perfectly flat under the pressure of bar clamps. The rack is made from industrial framing channel which is available under several trade names (Super Strut and Kindorf are two) at electrical and plumbing-supply houses. You'll need two lengths of channel, four $\frac{3}{8}$ -in. spring nuts (made especially for use with the channel), two homemade hold-down boards and other hardware as shown in the sketch.

To make the hold-down boards, glue two 1x3s together with $\frac{1}{2}$ -in. spacers between. Plane a slight curve on the bot-

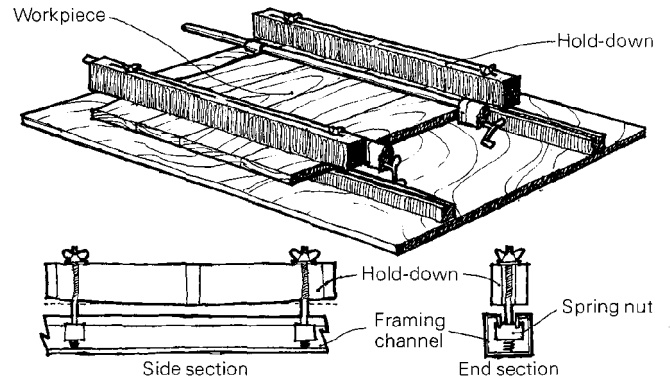

tom so pressure will be even along their length. Assemble the rack as shown. To use, slide the spring-nut/threaded-rod assembly right up against the edge-glued workpiece. Tighten the wing nuts to apply downward pressure and flatten the workpiece.

—Lloyd Winters, Ft. Wayne, Ind.

Jig indexing mechanism

This indexing mechanism can be incorporated into a variety of woodworking jigs for the table saw, drill press, overarm router, and other machines where accurately spaced cuts, dadoes or holes are required. The idea was originally given to me by Herman Kundera, a knowledgeable woodworker from San Bruno, Calif.

The mechanism consists of a spring catch mounted to the jig's fixed or base side and stops of finishing-nail heads set in the sliding side of the jig. The locations of the catch and the

nails can be reversed if it's more convenient. For precise, accurate spacing, predrill holes for the finishing nails with a slightly undersized bit. Vary the nail spacing as required for the particular job at hand. Although I made my spring catch from a piece of hacksaw blade (anneal for bending and drilling, then reharden and temper), any thin piece of metal would make a serviceable catch. Fasten the catch to the jig with a roundhead screw.

In using the jig you will slide one part against the other. The spring will ride up and over the nail head and then click down. When you feel the spring click, move the jig back until the spring catch registers against the nail. Now you're ready to proceed with cutting, drilling or whatever.

—Donald M. Steinert, Grants Pass, Oregon

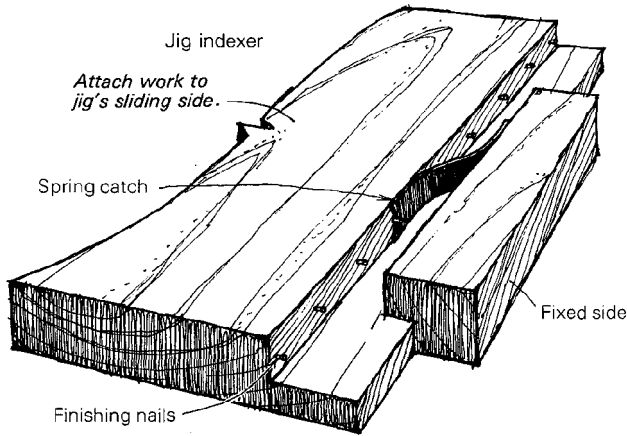

Chest lid stop

Here is a sketch of a chest lid stop that has worked well for me. It is simple to make and is completely out of the way when the lid is closed. The stop consists of two brass or aluminum plates, a short length of ball chain and a 30-caliber hollow-point bullet for weight. Drill a hole for the bullet in the side of the box and inlet the two plates to complete the construction. Be sure to position the top plate right over the bottom plate. Other construction details are shown in the sketch.

—John Warren, Eastham, Mass.

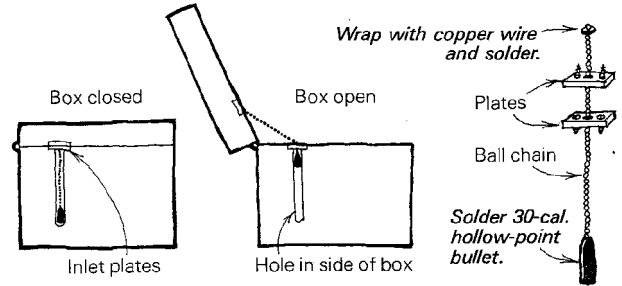

Cross-threaded faceplate

For years I have transferred lathe faceplate projects from the inboard spindle to the outboard spindle. Since the outboard spindle is left-hand threaded, this meant dismantling the work from one faceplate and mounting it on another. I recently simplified this procedure by cross-threading a spindle-sized nut and welding it to a 6-in. disc of 1/4-in. steel. Now I can transfer the workpiece from inboard to outboard spindle without changing faceplates. If you tap the nut freehand

you'll undoubtedly have a bit of wobble at one position of the other. Cross-threading does weaken the threads. But they are strong enough to take the forces encountered on a wood lathe.
 —*Johnathan D. Clark, Rochester, N.Y.*

Homemade glue bottle

Woodworkers who use white or yellow glue and favor a brush applicator will appreciate this homemade glue bottle. It's unbreakable, practically spill-proof and free. Just cut off the top of a plastic bottle at the shoulder, invert and press in place. As you use the glue be sure to push the top down to eliminate air in the container. Most glue drips will run back into the bottle, but those that don't will peel off easily.

—*Carl E. Roos, Pottsville, Pa.*

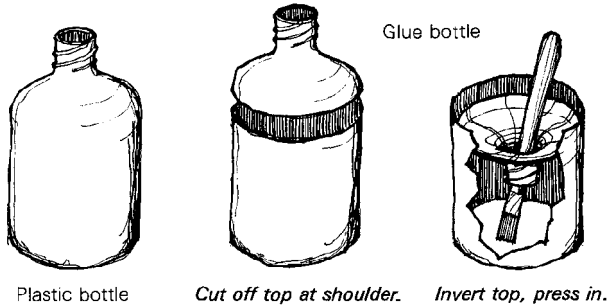

Glue spreader for lamination

This glue spreader makes easy the tedious job of covering thin laminations with just the right amount of glue. The heart of the spreader is a cork-covered cylinder. The cork has the right

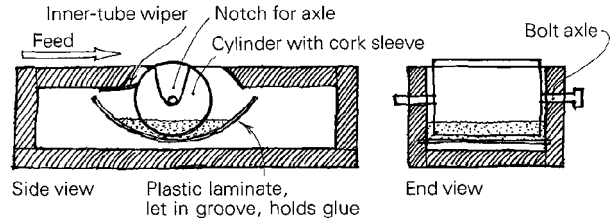

texture to pick up and deposit the right amount of glue. Make the spreader frame from plywood. Cut a semicircular groove in each side of the frame to hold a piece of plastic laminate which acts as a glue reservoir. Notch the sides of the frame so the glue-spreader cylinder can be removed for cleaning. Tack a piece of rubber inner tube to the frame so that it will scrape excess glue from the cylinder as it rotates. I use a commercial white glue mixed with water to get a better consistency for spreading. —*Rod Davidson, Port Angeles, Wash.*

Vacuum-aided oil finish

Here is a method for oil-finishing small articles such as gear-shift knobs and knife handles in dense hardwoods like cocobolo and rosewood. Normally, these woods don't readily accept oil to any depth. First I submerge the wood article in a jar of Watco oil and put the jar in a homemade vacuum chamber. I keep the wood under vacuum for several hours until it nearly stops bubbling. Then I slowly release the vacuum and allow the air pressure to push oil into the pores of the wood that formerly held air. After a couple of hours I remove the wood and wipe it dry. The deep penetration slows drying time somewhat. Our vacuum pump is an old compressor. We

hooked up the vacuum chamber to the inlet side. This method doesn't require a hard vacuum—any vacuum at all achieves a better result than just rubbing in the oil.

—Jerry Blanchard, Pebble Beach, Calif.

Cam hinge reveals hidden compartment

The sketch below shows how I used a modified hinged lid to construct a hidden compartment in the top of a bookshelf I was building. When the compartment is closed, there are no seams. The dowels lock down the front, making the top snug and tight. The pivoted cam rolls the top forward so it will clear the wall.

—James B. Eaton, Houston, Tex.

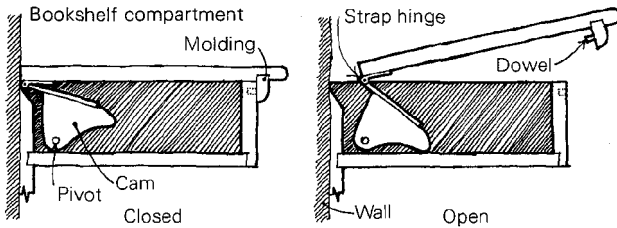

Aligning hinged box tops

To assure that the tops of small hinged boxes will align perfectly with the bottoms, seat the hinges first with "5-minute" epoxy and install the screws later. Smear a thin coat of the epoxy on the hinges, place them in position (separating the leaves slightly with a wedge if necessary) and put the top on the box, aligning all around. To be safe, give the epoxy a full half-hour to set, open the box top, drill pilot holes and install the screws.

—H. W. Reid, Cincinnati, Ohio

Edging with a leathercraft tool

To break the sharp, hard corners on straight or curved boards I use a simple tool that leather workers will find familiar. It's called a leather edger and is available in several sizes wherever leatherworking tools are sold.

If you're not near a source of leatherworking tools the edger is easy to make at home. Start by inserting one end of a 4-in. length of drill rod in a handle. Shape the other end of the rod into a curved fork with two tines about 3/8 in. long. Use the edge of a small rectangular file to cut the slot from the top and to form the appropriate cutting angle. Sharpen the cutting edge between the tines from underneath with a thin, rounded slipstone.

To use, push the tool along an edge with the grain. It should remove a thin, curled shaving and leave a delicately rounded edge in one pass.

—Norman Odell, Quathiaski Cove, B.C., Canada

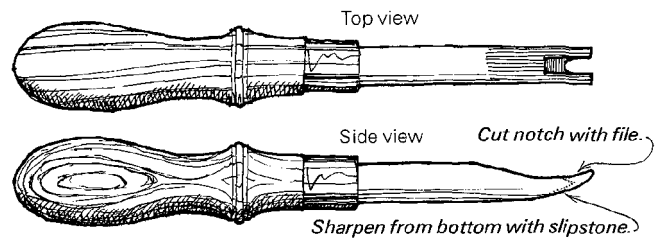

Methods of Work buys readers' tips, jigs and tricks. Send details, sketches (we'll redraw them) and photos to Methods, Fine Woodworking, Box 355, Newtown, Conn. 06470.

Roller hold-in for resawing

Before I built this roller hold-in, I found myself using one hand to hold the work against the bandsaw fence and the other to steer and feed the stock. I didn't feel balanced and comfortable, and my hands were too close to the blade at the end of the cut. The roller fixture that solved these problems cost me \$2.50, two hours of work and two trips to the hardware store.

The fixture consists of a base, two roller brackets and a roller. I made the base from plywood and glued and screwed it together for strength. Be sure to make the base large enough so you can clamp it easily to both the back and side of the saw table. I cut the roller brackets and turned the roller from maple. My version of the roller is about 1 1/4 in. in diameter and 5 1/2 in. long, an ideal size for my 8-in. resaw-capacity bandsaw. I turned the roller and the 1/2-in. axles as a single unit. An enhancement that I didn't include on my roller fixture would be to point the axle ends to provide a low-friction bearing where the axle runs in the brackets. Attach the roller brackets and roller to the base with bolts, washers and nuts as shown in the drawing. Be sure to use bolts with a smooth shank where they pass through the brackets, else the brackets will bind on the bolt.

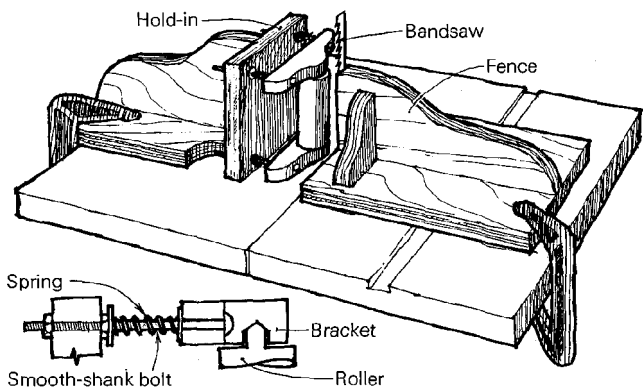

To use the hold-in, set the fence in position for the proper thickness of cut. Now bring the roller fixture into position and clamp so the roller exerts the proper pressure and touches the work just forward of the blade. If you use the narrow-faced fence shown in the sketch it is important to plane the stock between each resaw, because the narrow contact tends to duplicate any waviness or imperfection in the face of the stock. Reset the roller hold-in after each cut to regain the proper hold-in pressure. —Dennis LaBelle, *Traverse City, Mich.*

Jointing wide planks

Here's a way to joint those monster wide planks that are impossible to true on a jointer, no matter how strong you are. Clamp your raggedy edged board over a long, straight guide-stick and trim the edge square with a big (1 1/2-HP, 1/2-in. collet) router fitted with a flush-cutting spiral trimmer. Position the workpiece to overhang the guide-stick slightly so the whole edge gets machined in one pass. With a hardboard template the same setup can be used to smooth contours. Ocemco

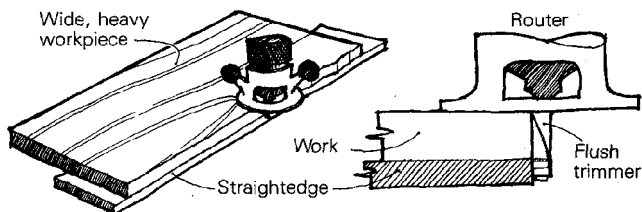

(1232 51 Ave., Oakland, Calif. 94601) makes a dual-bearing, 1/2-in. diameter, flush trimmer with two spiral flutes that's ideal. The trimmer, which sells for about \$30, is 1 1/2-in. long, limiting its use to 6/4 stock.

—Patrick Warner, *Escondido, Calif.*

Book-matched box

This simple book-matching technique yields a box with perfectly matched grain at all four corners. The system requires the rough lumber to be only as long as one side and one end of the box, but thick enough to resaw.

First resaw the box lumber. The inside surfaces match, so reverse them to become the outside of the box. Now cut the side and ends sequentially, keeping all the waste to one end as shown in the sketch. Assemble the box as you like. I prefer the dramatic matched effect of mitered corners, with spline reinforcements for strength. —Sam Bush, *Portland, Ore.*

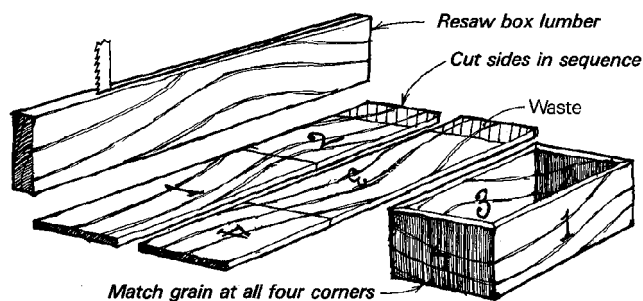

Jointing on the radial-arm saw

Lacking a jointer here's an improvised radial-arm-saw setup I devised to joint the thick oak boards I used in two butcher-block tabletops. First rip a thin board the exact thickness of the saw kerf of the blade you're using. Tack the thin board to the saw fence behind the blade. Bring the blade up against the fence and adjust so that the blade and the piece you've added to the rear fence are flush. If your setup is accurate, your fence is long and straight and your blade has 60 or more carbide teeth, you should get perfectly jointed edges ready to be glued up. Using variations on this fence, you can joint on the table saw and router table as well. —Dale Snyder, *Duluth, Minn.*

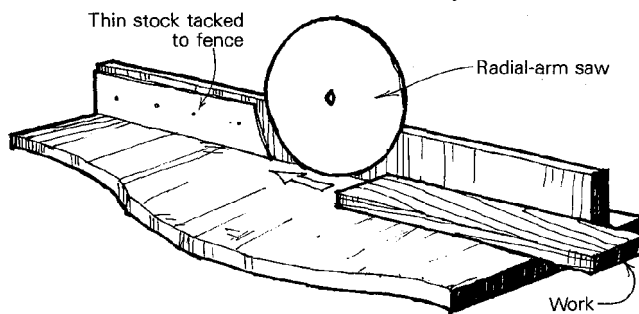

Fixing jointer-knife nicks

If jointer knives get nicked as a result of hitting a nail or whatever, you can slide one knife a fraction of an inch to the right and another knife a little to the left. Leave the third knife in its original position. Because the nicks do not come in line, the jointer will surface lumber as smoothly as it did originally.

—Eric Schramm, *Los Gatos, Calif.*

I solve the problem of a deeply nicked jointer knife by keeping an extra set on hand and replacing only one nicked knife with one from the spare set. Replacing one knife at a time saves on setup time and extends the life of the knives between

sharpenings. Of course, all six knives should be sharpened at once, ground to the same size.

—Arthur L. Fiest, Emmaus, Pa.

Hole-cutter for speaker enclosures

I have been involved in making professional sound equipment and speaker enclosures for a number of years. The usual construction routine requires me to cut holes up to 18 in. in diameter for speaker baffles. Here's how I use a modified router table to cut the holes accurately, quickly and safely.

My router table is constructed of $\frac{3}{8}$ -in. Baltic birch plywood. I've installed an aluminum-channel track and pivot assembly on the centerline of the table as shown in the sketch. The standard $1\frac{1}{2}$ -HP Makita router bolted underneath the table is equipped with a stagger-tooth cut-out bit (Wisconsin Knife Works #68802).

To cut a circle on the setup I first slide the pivot assembly to

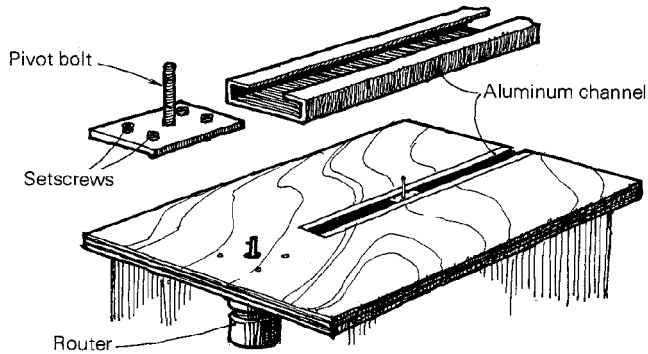

the right position for the radius I want. Then I lock the assembly in place by tightening the four setscrews. Next I drill a center-hole in the baffle board and slide this over the pivot assembly's threaded rod. I secure the baffle board with a flat washer and a self-locking nut. The baffle board should rotate on the pivot with a mild resistance. Next I turn on the router, bring it up through the wood and rotate the baffle clockwise on its pivot point to cut a perfect circle. Once the device is set, you can quickly reproduce duplicate baffles.

—James Campbell, Orange, Calif.

Ersatz sanding disc

A tire valve stem makes a cheap, simple and flexible mounting for sandpaper. Cut the stem from the tube, glue on sandpaper and chuck the stem in a drill press or portable drill. I use the discs to sand irregular bowls.

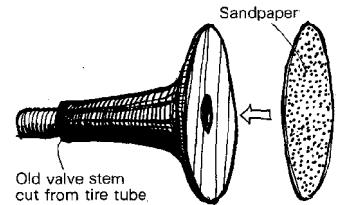

—Bart Brush, Cherry Valley, N.Y.

Spreading glue

In assembling doweled joints it is difficult to gauge the right amount of glue for the sockets. If you put in too much, the trapped glue acts as a hydraulic fluid, preventing the joint from pulling up. This simple tool solves the problem by assuring each socket has just the right amount of glue.

Select a short length of dowel the same size as the pins you're using and, with the dowel chucked in a drill, sand slightly undersize. Then saw a narrow kerf through the axis



slightly longer than the hole is deep. To use, apply glue to the sockets, then insert the kerfed dowel in each and twist. The tool squeezes excess glue out of the hole and evenly coats the socket.
—Duane C. Marks, Waltham, Mass.

I offer the following two tips for spreading glue in holes for dowels and on flat surfaces, as in edge-gluing. For dowel holes, take a pipe cleaner and fold it in half. Put glue into the hole and work it on the sides with the pipe cleaner. Use the pipe cleaner to put glue on the dowels. For edge gluing, apply a bead of glue from the container and use a toothbrush to brush an even layer of glue on and into the surfaces to be joined. Do not forget to wash out the toothbrush before you brush your teeth; discard the pipe cleaner.

—Arthur Witt, Jr., Columbia Mo.

Replacement router light

I own an older Stanley router with a built-in light. When I experienced difficulty finding the 18-volt replacement bulb, I fabricated a replacement using the base of the old bulb and a new automotive bulb. The rugged replacement is still burn-

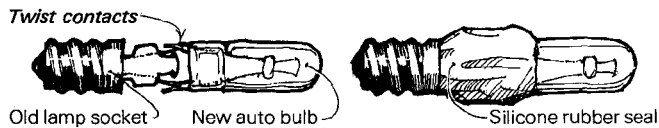

ing strong after four years. To make the bulb, remove the glass envelope from the old, burned-out bulb, saving only the socket with its two filament wires. Twist these to the contact wires on an automotive bulb (type 194 or equivalent). To support the structure and isolate the bulb from vibration, I dabbed silicone rubber (the kind sold for bathtub seal) at the base of the bulb.
—Salvatore Pontecorvo, Ft. Wayne, Ind.

Skewed jointing

When you're jointing wavy-grained, contrary woods like curly maple, a skewed cutting angle will often produce smoother results with less tear-out than a straight-on cutting angle. To take advantage of this effect simply attach a long wedge to the jointer fence.
—M. W. Uresti, Bryan, Texas

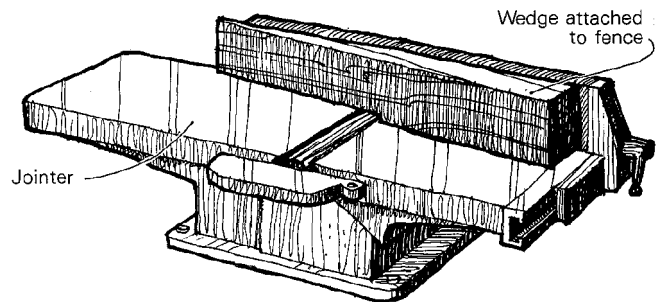

Producing round tabletops on the lathe

Here's how I use my lathe and a sanding disc to produce a perfectly round tabletop. First locate the center of the tabletop blank and cut it roughly to shape. Now cut a short length

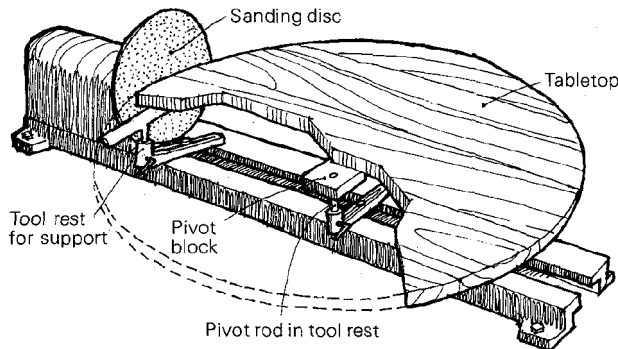

of metal rod that can be held in your tool-rest base. Using a bit the same size as the rod, drill part way through a piece of 2-in. scrap. Screw or clamp the scrap block to the underside of the tabletop at its center. Now mount the work on the lathe's tool rest with the block and the rod acting as a pivot. To level and support the work near the sanding disc, mount another tool rest parallel to and about 1 in. from the disc.

Now turn on the lathe and rotate the tabletop against the disc. If the pivot turns out off-center, loosen the tool rest. Advance the work and finish the entire circumference to the shortest radius. —Robert S. Maxwell, Washington, D. C.

Plywood edge-banding joint

This method for edging plywood is simple yet produces a very strong joint. The idea is to key the edge banding to the plywood via a simple tongue-and-groove joint, so there is no movement when you clamp up.

First rout a groove in the edge of the plywood using a $\frac{1}{8}$ -in.

slotting cutter bit. Take care to center this groove. To make the edging, rip solid stock into thin boards, $\frac{1}{4}$ in. thick and $1\frac{3}{16}$ in. wide. Using finger boards on the table saw as shown in the sketch, cut a shoulder on each side of the edging to produce a tongue that fits snugly in the plywood slot. It will take you a couple of tries to get the blade set at just the right height, but once it's set you can mill a hundred feet of edging very quickly. To complete, spread glue on the edging and clamp up. Later sand down the slightly thicker lip of the banding flush with the plywood. —V. Spiegelman, Los Angeles, Calif.

1. Rip edging stock.
2. Cut shoulders.
3. Groove plywood.
4. Glue and sand flush.

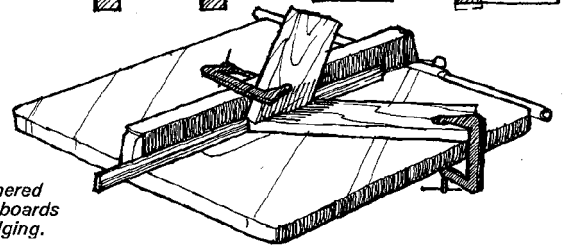
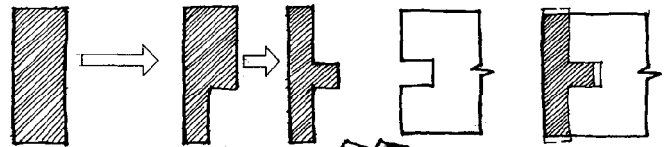

Wooden blanket for ribbed bending form

This flexible wooden blanket puts to bed the problem of form squeeze-marks on curved laminated panels. Used in

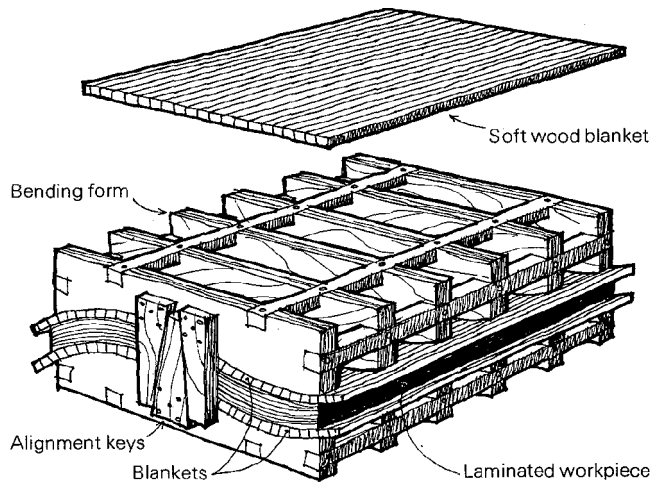

pairs (one above, one below) the blankets evenly distribute the pressure between the ribs of the form and smooth out small irregularities.

To make the blankets saw 1/2-in. sq. strips of a soft wood (I used basswood) and string them together with wire. Cut enough strips so the blankets are a couple of inches wider and longer than the workpiece. Drill the wire holes through the strips on a drill press using a fence and stops to ensure the holes are lined up. Drill the holes a little oversize. This makes stringing easy and allows the strips to move freely as they adjust under pressure to the contours of the bend.

In use I place a piece of 1/8-in. plywood or cardboard be-

tween the blanket and the laminated panel to further smooth out the pressure. Form alignment is critical to an accurate curve, so I use indexing fingers (two on the top mated with one on the bottom) as shown in the sketch.

—Robert Thomason, Providence, R.I.

Bull-nose tailstock

I frequently turn pieces that I have drilled out or turned hollow. To support these pieces for further turning and finishing, I use this large-diameter bull-nose tailstock. To make it, remove the metal center from a 60° ball-bearing center and replace it with a larger, turned hardwood cone. Turn a tenon on the base of the cone to fit the ball-bearing center, as shown in the sketch. I have several hardwood inserts of various sizes to fit different projects. All fit the same, single-ball-bearing center.

—Ted Ringman, Barrington, Ill.

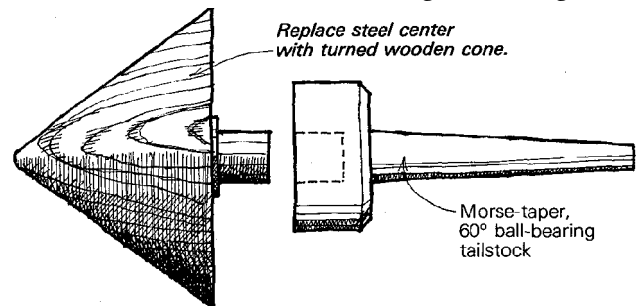

Methods of Work buys readers' tips, jigs and tricks. Send details, sketches and photos to *Methods*, Fine Woodworking, Box 355, Newtown, Conn. 06470.

Two plywood dollies

Struggling with sheets of plywood is a real strain on my back, so I built this plywood dolly that makes handling those sheets easy. When I bring plywood to my shop in my pickup truck, I wheel the dolly up to the back of the truck with the cradle locked in the horizontal position. Then I slide the plywood from the truck onto the dolly with the long edge of the sheet resting against the foot. To tilt the cradle for transporting I just tap the locking bar with my foot to allow the cradle to swing to the vertical position. The cradle, when loaded with plywood, is almost evenly balanced but with a little more weight on the side with the foot. That way the cradle always tips the right way. When I wheel the plywood up to the saw, I tilt the cradle back to the horizontal position where the locking bar falls into a notch and locks. Since the dolly is the same height as my saw I can feed the plywood directly into the saw from the dolly.

—R.W. North, Burbank, Calif.

I've used the dolly sketched below right for years to handle large, heavy panels. I use it to tilt the panels up to the top of my table saw and unload panels from my truck. It also serves as a roll-around stepladder and a portable work surface.

—Ben James, Jacksonville, Fla.

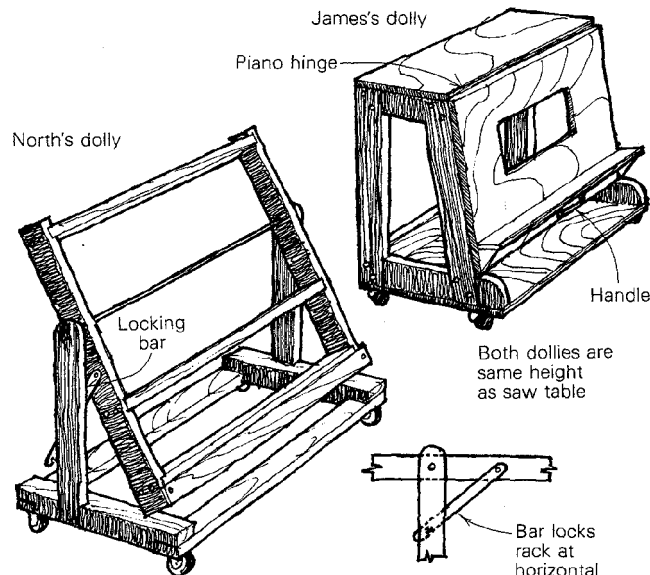

Improved spade bit

You can improve the performance of the common spade bit by regrinding it to the shape below. The reground bit will cut a smoother hole and won't tear out the grain as much when it comes out the other side.

—Ray Yohe, Altoona, Pa.

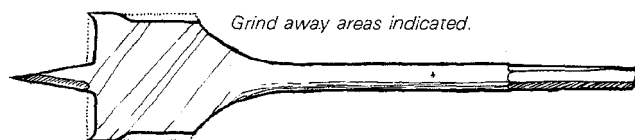

Pipe-clamp shave horse

At the summer camp where I work we introduced high school kids to the kind of woodworking that might have been done by Michigan settlers before electricity; each student made a mallet. First he split out an oak handle with a froe, then shaped it with a drawknife on a shaving horse. Next he worked on the mallet head. We soon realized that, while the shaving horse worked well for the long handles, the short heads were tricky to hold and work in the horse. To solve the problem I

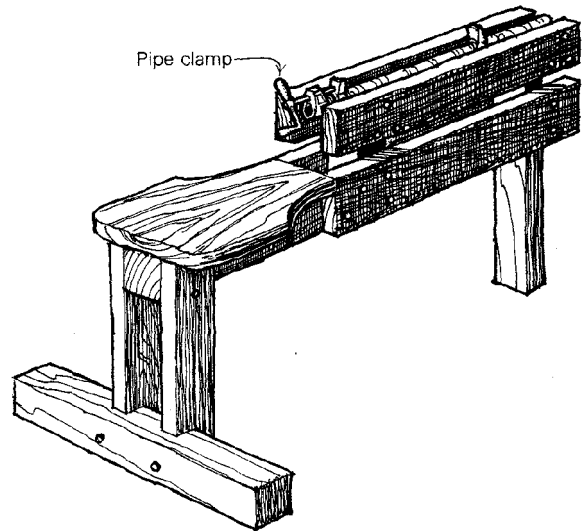

designed and built an alternative to the traditional shaving horse that uses a pipe clamp to hold the work.

The horse's frame is made from 2x4s, 2x6s and 4x4s bolted together. To fasten the pipe to the frame I drilled two holes through the pipe to take a 3/8-in. threaded rod. Each threaded rod has four nuts, one on each side of the pipe and one on each side of the horizontal top member of the frame. I countersunk the outside nuts so there is no danger of striking them with the drawknife.

—Mark Lankton-Lenzo, Saugatuck, Mich.

Routed miter joint

I recently had to make two 24-in. long splined 45° miter joints to join a coffee-table top to its sides. Since the tabletop was too large for me to use my table saw, I devised a way to cut miters and spline grooves with my router and a simple homemade jig.

To make the jig, select a 2x4 slightly longer than the required joint and, using a carbide-tipped blade for smoothness, rip the board at 45°. Glue and screw the smaller piece to the main piece to extend the face of the jig, as shown in the sketch. Rip a 1/4-in. groove a little less than 3 in. from the pointed edge of the jig and install a spline in the groove. The spline serves as a straight-edged guide for the router's base.

To use the jig, rough-cut the workpiece at 45°, leaving it about 1/8 in. long. Position the jig exactly on the cut line and

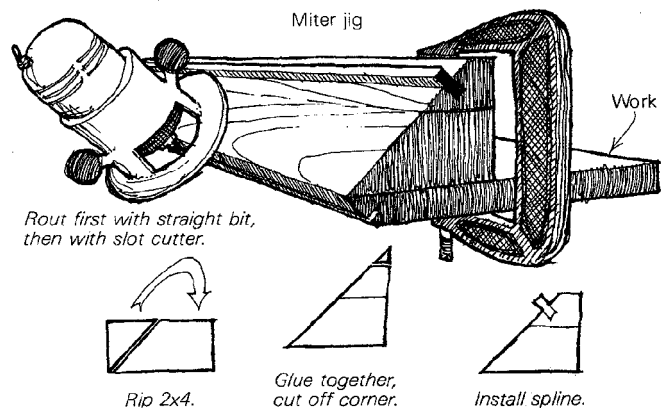

clamp in place. Chuck a double-fluted carbide straight bit in your router and feed the router along the jig slowly and carefully. The ends are especially delicate. After the mitering cut is complete, leave the jig in position, chuck a slot cutter in the router and rout the spline slot. For a blind spline just stop the cutter an inch or so from the end. Repeat the process on the

matching 45° piece. If the jig is made accurately, you'll be amazed how perfectly the joint will turn out.

—Paul Darnell, Phoenix, Ariz.

Space-age saw guard

This table-saw guard, developed for cutting space-shuttle insulation, holds several advantages over conventional guards. Because it is counterbalanced, the guard makes lighter contact and is easier to operate, especially with thick materials. By sliding the counterweight up or down the arm, the operator can adjust the downward force of the clear plastic en-

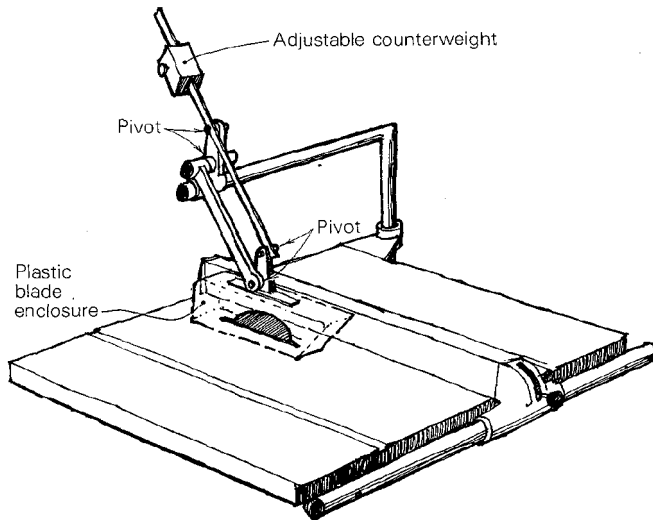

closure. The guard doesn't preclude dadoing and grooving operations, which are impossible with some other types of guards. The design was developed by Benjamin R. Dunn and Paul P. Zebus of Rockwell International.

—NASA Tech Briefs, Johnson Space Center, Tex.

Adjustable curve

To make this adjustable curve, start with a piece of fine, straightgrained hardwood—hickory is best. Cut a ¼-in. thick strip about 36 in. long and 1½ in. wide. Now taper the strip to ¾ in. wide and ¾ in. thick at one end. Glue a reinforcing patch on the thin end and saw a small notch in each end of the piece. To complete the curve tie a series of knots in a string and string up the curve like a bow. Unstring the curve when it's not in use.

—Floyd Lien, Aptos, Calif.

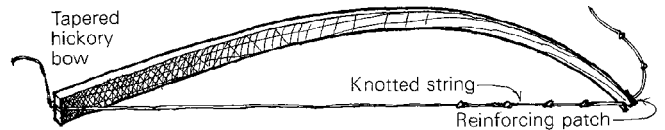

Edge gluing without clamps

Here's how I edge-glug boards using wide masking tape rather than clamps. First be sure your boards mate perfectly; the finished joint is no better than the initial fit. Now with the boards on a flat bench top, pull the joint together and run a strip of tape down the joint, spanning the crack with the tape. Turn the boards over, pull the boards to the edge of the bench and let one board drop a wee bit. Put glue in the open crack and flex the boards like a hinge until the joint is covered with a layer of glue. Slip the boards back on the bench, pull the joint

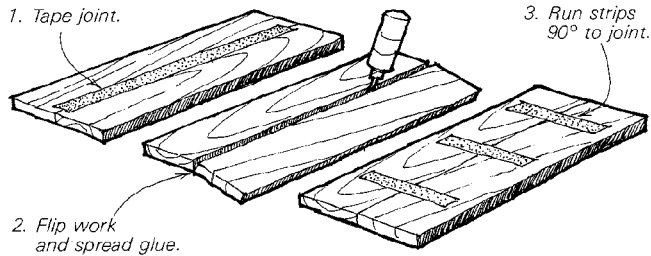

together hand-tight and, after pausing a few seconds to allow the excess glue to squeeze out, run two or three strips of tape across the joint at 90°. A distinct advantage of this technique is that the boards don't slip out of position as they sometimes do under clamps.

—V.L. Luther, Tarrant, Ala.

BRUCE HOADLEY COMMENTS: Luther's system would, as he suggests, be no better than the quality of surfacing and evenness of glue spread. I can believe that a strong joint could be attained, but I don't believe it would consistently equal the strength of a clamped joint. However, most glue joints are far stronger than they need to be.

Aside from the strength issue, the taping approach has some important advantages in handling. First, it indexes and holds the pieces conveniently. Second, it enables both surfaces of the joint to be spread simultaneously while controlling the excess from dripping. Third, it eliminates the squeeze-out from at least one face of the assembly, which could be extremely beneficial in later stages. In summary, I think the idea has advantages that would pay dividends when combined with more standard clamping methods.

Counterbalance improves belt sander

The belt sander can be a valuable tool in the production-shop world of tight schedules and competitive prices. But most belt

sanders are designed with a flaw that renders them difficult to control: The motor hangs off one side, throwing the machine off balance. Unless you apply constant corrective hand pressure the sander will gouge or edge-scoop the work. A balanced machine will not scoop and allows the user to concentrate on direction and coverage.

To correct the imbalance I add wood and lead weights to my belt sanders. The amount of weight and position will vary with the sander. Fasten the weight under handles, knobs or whatever. The counterbalanced machines pass my test when they balance on a 1/4-in. thick piece of plywood set under the centerline of the belt. —Rod Goettelmann, Vincentown, N.J.

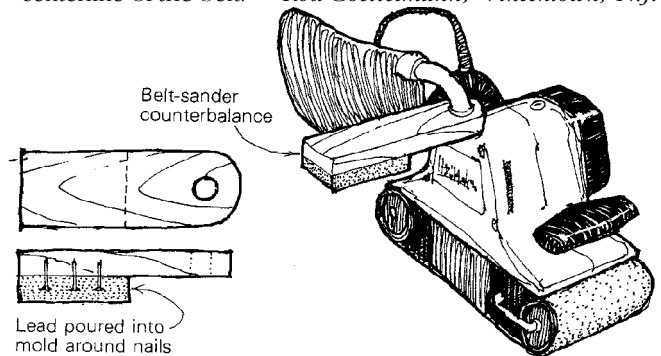

Planing thin stock

I have found that the following procedure for preparing small pieces of veneer works well. Bandsaw a 1/8-in. thick slice from the desired veneer stock which has already been planed. Then glue the slice to a scrap board with rubber cement. Apply the

rubber cement to both the scrap board and the smooth side of the $\frac{1}{8}$ -in. thick slice. Press the two pieces together after the cement has dried. With the scrap as a base you can hold the work securely for planing to final thickness. To remove the veneer, insert a putty knife between veneer and scrap; then slide it along the scrap. Rub the veneer with a rough cloth to remove the remaining rubber cement.

—Alan U. Seybolt, Harwich, Mass.

Here's how I safely smooth resawn veneer on the jointer. I secure the veneer to a flat back-up board with double-stick carpet tape. The back-up board holds the veneer flat and gives it the stiffness it needs. If the veneer is short or narrow I tape scraps of the same thickness to the back-up board to keep it from tipping. Set the jointer for a light cut and proceed slowly.

—Rock Thompson, Centerville, Utah

Brad-setting tool for tight places

Here is a simple tool to set brads or escutcheon pins in tight places. It consists of a 16d nail and a 3-in. brass tube that slides over the nail. Grind the point of the nail flat, dimple the end with a center punch, then drill a small cup with a no. 32 drill

Brad setter

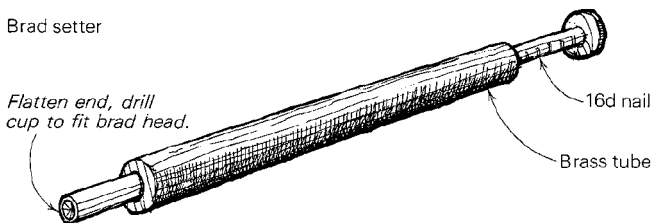

bit. To use, set the brad in its pilot hole, drop the tube over the brad to the work surface and tap the brad home with a small hammer.

—Malcolm Murlless, Staunton, Va.

Outdoor workbench

I needed a small outdoor bench for fair-weather work outside my shop and demonstrations at the county fair. To make the bench I cut a beefy slice of oak tree and mounted it on three legs canted outward. For the "vise," I fitted the bench with holes for my cast-iron hold-down (available from Woodcraft Supply, 313 Montvale Ave., Woburn, Mass. 01888, and other suppliers).

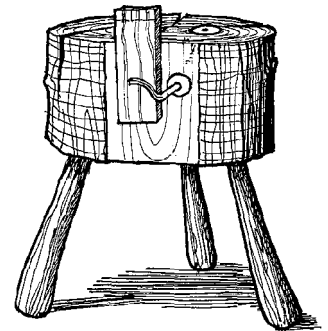

I bored a 2-in. hole into the top of the bench clear through to the bottom (so rainwater wouldn't collect in the hole). Then I plugged the top 2 in. of the hole with hardwood and centerbored the plug to fit the hold-down shaft. I flattened a place on the side of the oak slice and fitted a plug as above so I could use the hold-down to clamp work vertically. The arrangement works surprisingly well.

—J.B. Small, Newville, Pa.

Maintaining sharp carving tools

I ran across this tool-sharpening trick on a trip to Mexico. There I watched a carver working on mahogany chairs frequently plunge his gouge into a pine bowl full of some waxy sub-

stance. Upon inquiry he said the bowl contained a mixture of beeswax and fine carborundum abrasive powder. The plunging kept a keen edge on his sharpened carving tools. When I returned home I tried the trick and found it to work fine—especially on a warm day or near a stove so the wax stays soft.

To make the concoction, warm up ½-lb. of beeswax and knead in two or three tablespoons of 400-grit or 600-grit carborundum powder. The grit is available at any lapidary shop. To protect your carving tools, keep the mixture in a softwood box or bowl.
—Jim Thomas, Cerrillos, N.M.

Portable table saw

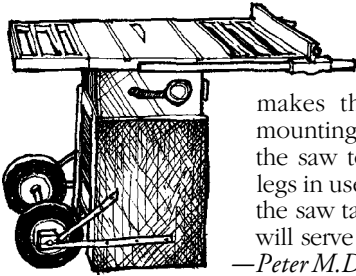

I have fitted wheels to my table saw, as shown in the sketch at left. The arrangement makes the saw portable (without mounting it on a dolly), but allows the saw to sit on its own four stable legs in use. You can fit handles under the saw table, or extended fence rails will serve the same purpose.

—Peter M.D. Darbishire, Hensall, Ont.

Magnetic pipe-clamp pads

The best pipe-clamp pads I've seen were made by facing hardboard with sticky-back magnetic tape. The hardboard is hard enough to resist deforming yet soft enough to not mark softer woods like walnut and mahogany. The magnetic tape holds the pads in place better than a third hand, yet the pads are easily removed. Magnetic tape (I used 3M Plastiform brand)

can be obtained locally at sign shops and some hardware stores, or it can be mail-ordered from Woodcraft Supply, 313 Montvale Ave., Woburn, Mass. 01888.

—Mike Graetz, Lakeland, Minn.

Reducing the diameter of dowels

The sketch below shows an old patternmaker's trick to reduce the diameter of a dowel. Simply chuck a router bit in a drill press and clamp down a couple of scrap blocks to guide the dowel and to serve as a length stop. Lower the quill to take a light cut, lock the quill in place and rotate the dowel under the bit. Continue taking light cuts until you're at the desired diameter.
—Wallace C. Auger, Fairfield, Conn.

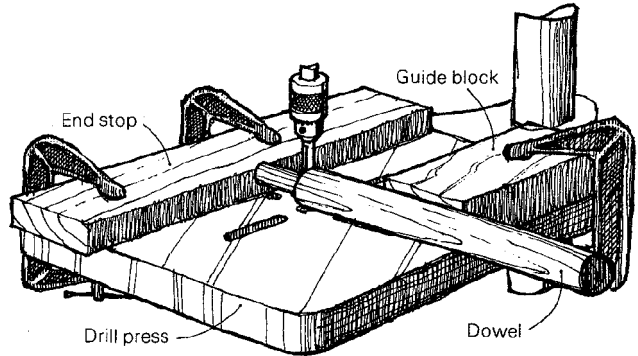

Methods of Work buys readers' tips, jigs and tricks. Send details, sketches (we'll redraw them) and photos to Methods, Fine Woodworking, Box 355, Newtown, Conn. 06470.

More jointer-knife sharpening jigs

EDITOR'S NOTE: We've published several jointer-knife sharpening jigs in past Methods of Work columns (see *FWW* issues #30, #27 and #23). Each one has prompted readers to send us letters with refinements, variations and new ideas.

However, to add a point of caution to all these methods based on the table saw and drill press, Carl Henry of Houston, Texas, writes: "At a wooden-boat school I attended last summer we used a grinding wheel mounted in a table saw to remove a lot of metal from a set of large planer knives. An hour later smoke began to pour from the sawdust in the saw's base. The hot embers from the grinding had been smoldering there in the sawdust. I recommend cleaning out the saw completely before and after sharpening."

John Gibbons of Madison, Wis., adds another cautionary note: "Grinding operations on the table saw spray a stream of abrasive dust all over the saw's gears, trunnions, bearings and other working parts. This grit will cling to these parts and grind away at their machined surfaces. Those who expect continued smooth operation of their machinery would be well advised to avoid such abusive practices."

For those who will take the necessary precautions, here are three more ways to sharpen jointer and planer knives. —Jim Richey

Here's a simple jig I use on my table saw to sharpen the knives of my 16-in. thickness planer, different from the methods in *FWW* #30, Sept. '81. The jig is nothing more than a block of hardwood with an angled shoulder to give the right sharpening angle. The knives on my planer are slotted so I use screws and washers through the slots to fasten the knife in place.

To use the jig I put a fine-grit 6-in. abrasive wheel on the tablesaw arbor and tilt the arbor to 45°. I use the rip fence for rough adjustment and the blade-height crank for fine adjustment. —John Kolkman, Thornhill, Ont., Canada

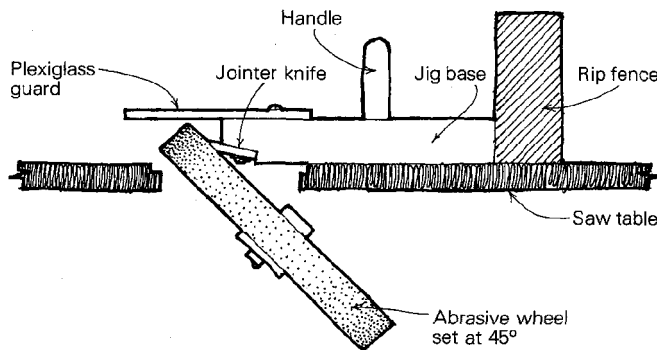

I built several variations of the cup-stone-in-drill-press jointer knife sharpening jigs described in the Methods of Work column (*FWW* #23, July '80 and #27, March '81). All proved unsatisfactory because they either distorted the blade or didn't hold it securely. However I've modified the design of the knife-holder block and have had good success.

Start with a maple 1x3 a couple of inches longer than the jointer knives. Drill a 1/4-in. hole at each end across the width of the block. The distance between holes should be about 1 in. greater than the knife length. Drill an additional hole midway across the block well below the centerline. Now cut a groove in the block at the sharpening angle (I used 36°), but don't cut into the hole you drilled midway across the block. Flip the board over and cut the board so that it looks like the sketch at the top of the next column. Insert 1/4-in. carriage bolts in the holes, insert the blade in the slot and tighten the nuts. Don't over-tighten, or you'll distort the blade.

The knife holder can be fastened (glue one part only) to a base and slid under the cup-stone freehand. Or you can devise a two-part jig with a sliding track in the base as shown with other holders in the Methods column.

—George Pfeiffer, Seward, Neb.

To make knife holder...

1. Cut knife slot.

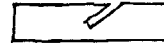

2. Flip and part.

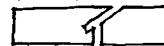

3. Install bolts to hold knife.

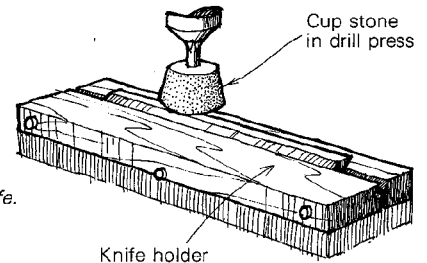

The sketch below shows my method for grinding jointer knife blades on the table saw. The blades are ground on the circumference of the grinding wheel, not the side.

A similar setup allows blade grinding on the radial-arm saw. Clamp the blade holder to the table parallel to the saw arm. Mount the stone in the saw arbor and run the arbor/stone unit back and forth on the radial-arm to grind the knives. Feed the stone by lowering the arm. —Mark Palmquist, Lilburn, Ga.

Table saw

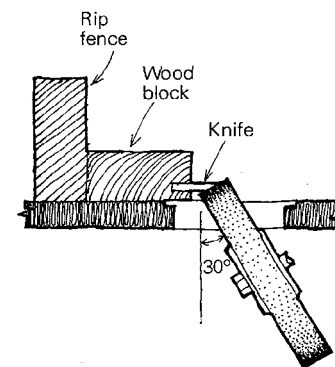

Radial-arm saw

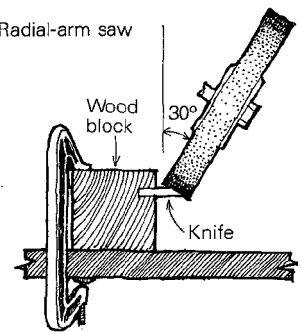

Expansion chuck

I needed a lathe chuck to hold work without screw holes. This shopmade expansion chuck is invaluable for turning small trays, dishes and vases. A single 1/4-in. machine screw pulls a tapered wooden plug into a matching tapered section thereby expanding the chuck and tightening it in a prepared recess in the base of the workpiece.

Make the chuck from a block of hardwood (I used Honduras mahogany) that has been permanently screwed to a small faceplate. Since the wood grain is perpendicular to the faceplate, install three birch dowels in the base of the block to increase the holding power of the mounting screws.

The overall shape of the chuck is somewhat arbitrary, but proper expansion can be achieved only if the webs are thin. After you have turned the outside to shape, carefully hollow the inside to give about 1/8-in. thickness to the web region. Fit the plug blank with a threaded steel insert, then turn the plug to match the taper of the chuck body. A 7° taper is about

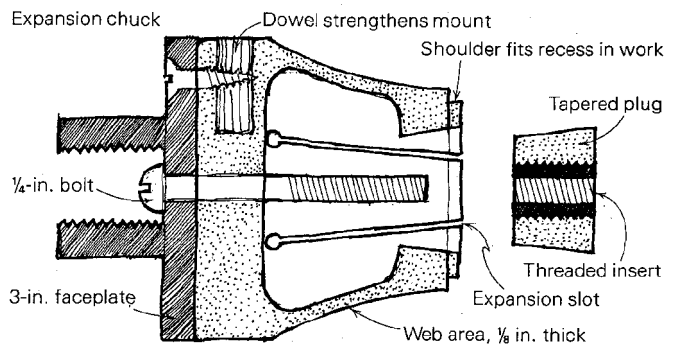

right. After turning is complete, drill stop-holes and cut eight expansion slots in the chuck body.

—R.E. Hollenbach, Livermore, Calif.

Increasing the bandsaw's throat capacity

To increase the throat capacity of my bandsaw, I designed two blade guides to replace those provided with the saw. The new guides twist the blade outward 25°, as is done on a metal cut-off saw. The guides were made from maple and fitted with three 3/8-in. ball bearings held in place with screws. Two of the bearings act as the side guides and the third is the back-up bearing for the blade. Of course the guides had to be designed within the limitations and characteristics of the bandsaw.

The results were gratifying; I can now crosscut a 10-in. board without the board hitting the bandsaw's column.

—Ralph Luman, Virginia Beach, Va.

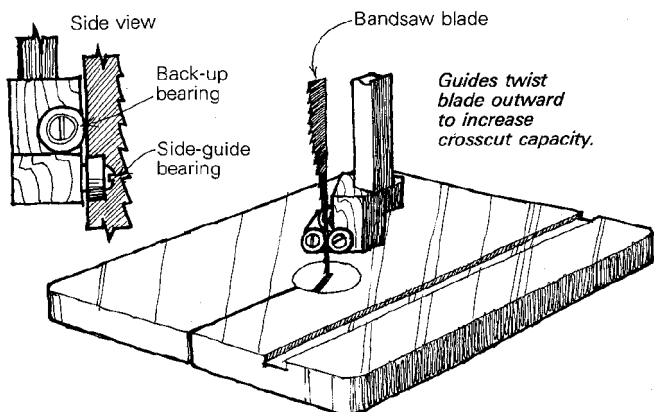

Clearing a clouded finish

It's a hot, muggy day and you've just shot a heavy coat of lacquer on a nice project. A few minutes pass and you discover the finish has clouded with moisture. Here's how to clear the finish. Shoot the clouded area with acetone. The acetone will clear the finish and bring the moisture to the surface. Quickly wipe it off. To continue, thin the lacquer and shoot sparingly.

—Robert M. Vaughan, Roanoke, Va.

Woodworker's knife

This knife design with a triangular head sharpened on two sides is especially useful to woodworkers. The blade cuts not only like a conventional knife, but it also cuts on the pull stroke. This gives very good control and leverage, and makes the knife usable in situations where the chisel is inadequate. I've used it for whittling, for scoring, for cutting patterns in veneer and even for trimming brush on fishing trips.

—John Marcoux, Providence, R.I.

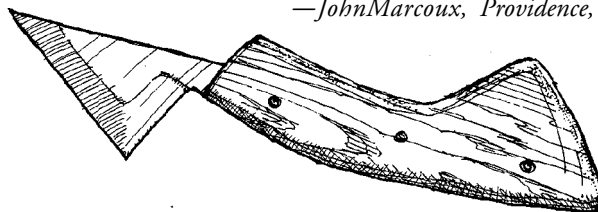

Wedged loom joint

I devised a wedged half-lap joint to replace the tusk-tenon joint traditionally used in loom construction. The joint fills all the requirements I wanted: it can be taken apart, won't vibrate loose, is easy to make and finishes flush and neat. In my ver-

sion the joint members are made up from two face-glued planks. The double-plank approach greatly simplifies cutting the joint and fitting the mortise to the tenon.

To make the joint, start with one of the four boards that will later form the mortise. Crosscut the board with the miter gauge set at 88° and the blade angled at 15° to make both sides of the mortise (flop one board). Miter the end of the tenon backup board at 30° and then cut a 30° notch in the mortise back-up board. The mitered end should wedge tightly into the notch.

To make the tenon, first locate and drill a large hole on the tenon's centerline. This hole helps prevent the joint from cracking and allows the tenon walls to flex. Next bevel the sides of the tenon at 15° and cut the angled slot for the wedge. The sides of the tenon should be left parallel. Later the wedge will spread them to fit the angled mortise.

Glue the tenon to its mitered backup board. Place this member in position on the mortise back-up and fit the

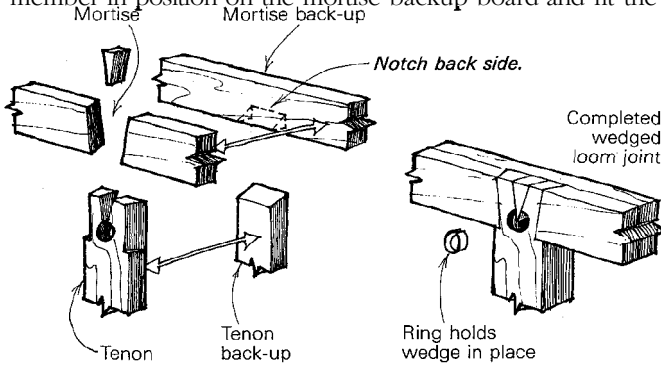

two mortise pieces against the sides of the tenon; the mortise pieces touch the tenon only at its shoulder. Mark the position of the mortise pieces, remove the tenon member and glue the mortise pieces in place. After the glue sets you're ready to assemble the joint by tapping in the wedge.

I recommend you oven-dry the wedges for two hours or so before you drive them in. This will reduce the chance of their shrinking and needing to be driven in further after you've trimmed them flush. Even so, leave the wedges in place for a few weeks before finishing flush. If the wedges persist in loosening, cut a short section of brass tubing the same diameter as the tenon hole. Cut a tapered section out of the ring so that, when inserted in the hole, it bites the wedge where it enters the hole. —Irving Sloane, Brussels, Belgium

Holding cabinets in place

If you make a lot of kitchen cabinets and work alone, as I do, you know that it is difficult to hold the cabinets in position while you're fastening them to the wall. This method uses pipe clamps to solve the problem. Remove the screw end from your long pipe clamps. Slide the adjustable stops up the clamps and use the clamps to wedge the cabinets in place.

—Randy Hazlett, Ashland, Ohio

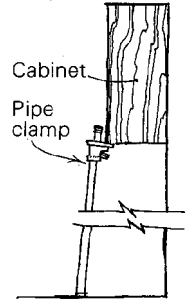

Flush rule joint for oval tables

Simon Watts says (in his article in *FWW* #18, P. 62) that he does not like "oval-shaped drop-leaf tables because the curve crossing the rule joint makes part of the joint project in an un-

sightly way." I agree that the projection is unsightly, but there's a simple solution that makes the rule joint flush in both the open and closed positions: bevel the edge of the table top.

Figure 1 shows how the corner of a rule joint projects when the leaf is lowered. The edge of the table continues to curve whereas the top corner of the rule joint swings down in an arc perpendicular to the line of the rule joint. But if the edge of the table is beveled at angle a determined from the tangent to the oval at the rule joint, the lower edge of the table top is farther out on a radius than the top corner of the leaf. When the leaf drops (figure 2), the edge and the corner match.

Recently I made a drop-leaf table incorporating this method and was pleased with the result. Later I visited Williamsburg

and noticed that many of the oval drop-leaf tables of colonial times also have beveled edges. So, my idea is far from original.
—James H. Smith, Champaign, Ill.

Edge-sanding fixture

Here's a fixture that turns a belt sander into an edge sander. Simply build a wooden fixture that supports and locks your belt sander in a horizontal position. Bolt the fixture to the table saw's rip fence as shown, and use the saw's flat cast-iron surface for the work. —Wayne Hausknecht, Tucson, Ariz.

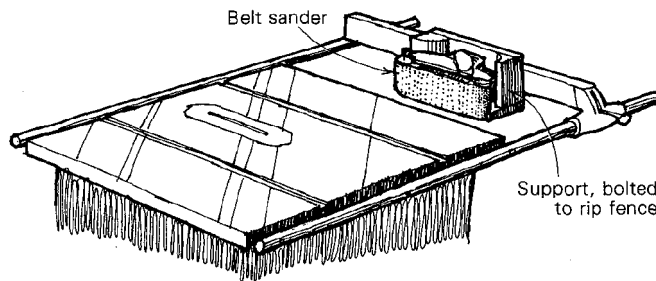
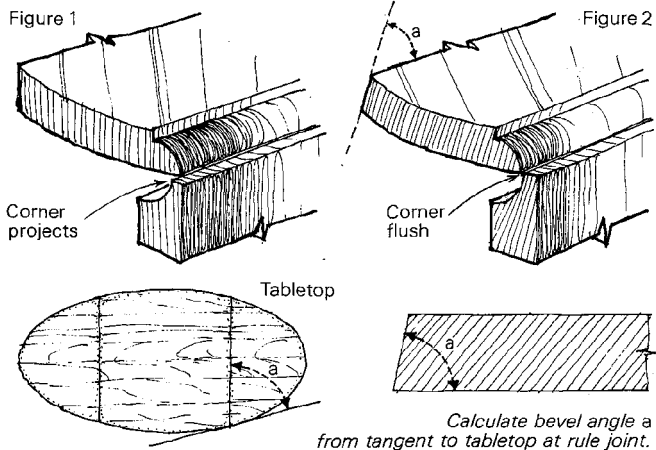

Two boss spinners

While visiting a woodworking pattern shop I ran across this tool called a "boss spinner." It is used with a disc sander to make wooden discs of varying diameters and thicknesses. As I found it, the unit was made from wood. Aluminum would perhaps give more accurate adjustment.

The boss spinner consists of three main parts: a slide bar that fits the channel in the sander table, an adjustment plate and a swing arm. A slot in the adjustment plate allows gross

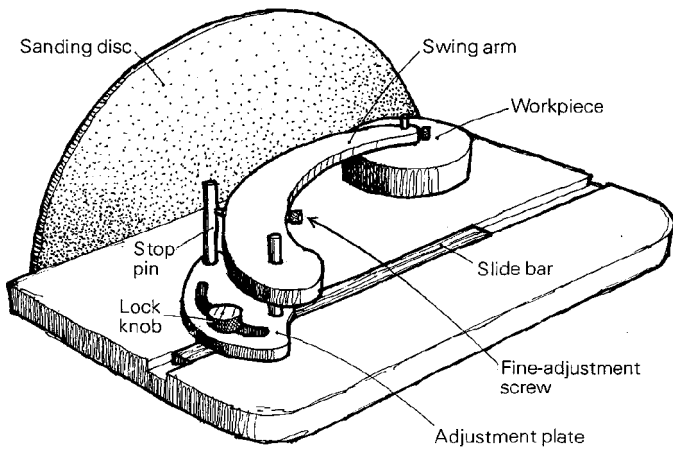

circle size adjustment while a screw in the swing arm provides fine adjustment. The sketch shows only one pivot hole and adjustment screw in the swing arm. You can extend the capacity of the spinner by drilling a series of pivot holes and installing a fine-adjustment screw for each position.

To use the boss spinner, first set the rough radius: With the fine-adjustment screw against the stop, rough-adjust the radius of the disc with the adjustment plate and locking knob. Set the rough radius about $\frac{1}{16}$ in. oversize. Now position the circle blank under the center pin. Feed the workpiece into the sander and rotate by hand until the fine-adjustment screw hits the stop. From there, use the fine adjustment screw to reach the final diameter.

—Richard M. Williams, Cleveland, Ohio

My circle duplicator uses $\frac{3}{16}$ -in. thick aluminum for its arm, adjustment cam and base, which is laminated with epoxy to a piece of hardboard that slides in the slot of my disc sander. Start with rough, oversize blanks and position the adjustment cam so that when the swing arm touches it, you have an accurately sized disc. The cam can be locked in position for accuracy. My device handles diameters from 2 in. to 6 in.

—Jay Wallace, Ashland, Ore.

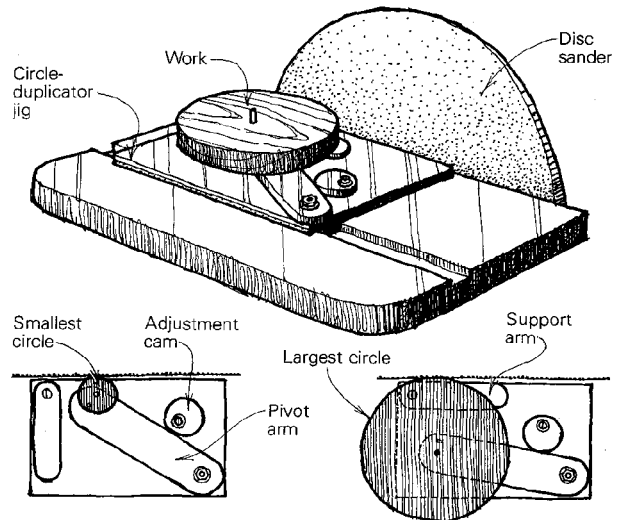

Methods of Work buys readers' tips, jigs and tricks. Send details, sketches (we'll redraw them) and photos to *Methods*, Fine Woodworking, Box 355, Newtown, Conn. 06470.

Two methods for turning duplicates

Turning copies of a spindle on a hand lathe can be tedious work. Templates, gauges and other gadgets help but don't substantially increase speed and accuracy. In contrast, this method, which uses the bandsaw, is the best turning aid I've found yet. On one face of the square stock, mark out with a template the desired profile and make bandsaw cuts to within $\frac{1}{16}$ in. of the profile at convenient reference points. Bevel the square's corners as you usually do, mount the stock on the

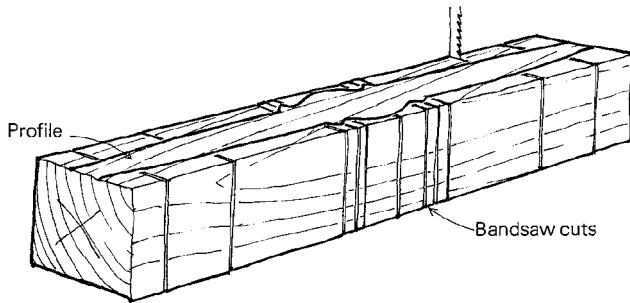

lathe and begin turning. The cut lines will be easy to see and will allow quick and accurate shaping without so many stops for caliper checks. The secret to this method is accurate layout and careful sawing. —Robert M. Vaughan, Roanoke, Va.

Lee Watkin's method for making dowels using a router and lathe (*FWW* #25, p. 22) arrived just before I put the finishing touches on the deck I was adding to my house. Here's how I adapted his method to make the deck railing a cut above the usual. Starting with the straight U-shaped fixture used to make dowels, I sawed off a curved section from each end. I screwed a V-shaped block to the bottom of the router base. This allowed the router to follow the profile of the top of the fixture and to transfer the shape to the spinning blank below. The shape I wanted in the railing spindles was similar to the backrest supports in a chair. The fixture helped me produce 85 identical spindles quite nicely.

—Donald B. Sherman, Merrimack, N.H.

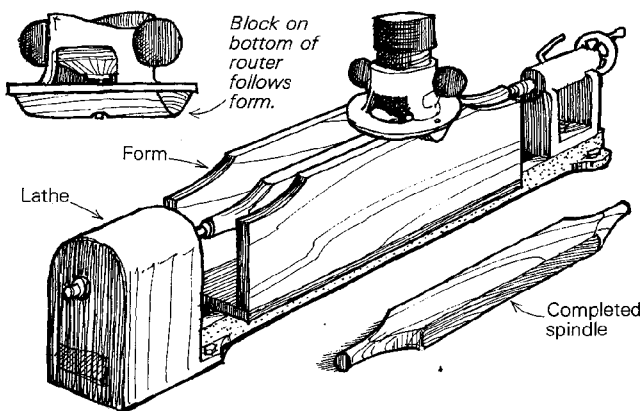

Routing splined miter joints

This router-based method for cutting the slots in splined miter joints is easy to set up and guarantees an accurate fit. First miter the panels in the normal fashion on the tablesaw and clamp them face-to-face as shown in the drawing, top right. Wide or bowed panels may require the addition of a stiffener clamped below the miters. Now chuck a spline-sized bit ($\frac{1}{8}$ -in. or $\frac{3}{16}$ -in. for $\frac{3}{4}$ -in. stock) into the router and set the depth of cut ($\frac{1}{4}$ in. to $\frac{3}{8}$ in.). Adjust the router guide to be

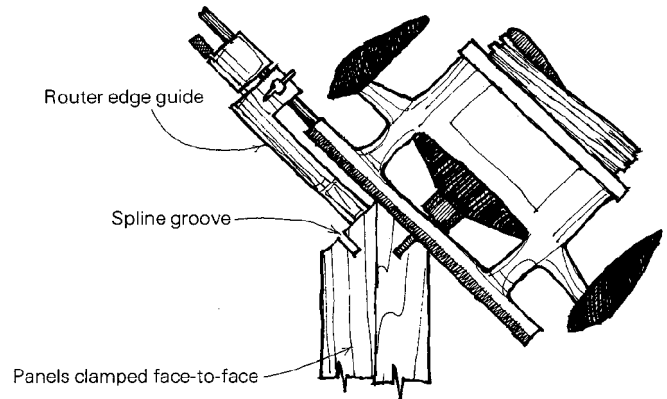

about $\frac{3}{4}$ in. from the bit. Absolute accuracy in depth and guide settings is irrelevant. Rest the base of the router on the peak formed by two panels and rout a spline slot in each panel. To cut a stopped spline slot, just plunge the router.

Although the whole process can be accomplished with little more than eyeball measurement, the right angle formed by the two miters and the constant offset of the cut all but guarantee success. —Warren H. Shaw, San Francisco, Calif.

Space-saving saw setup

Here's one solution to the problem of squeezing both a tablesaw with long extension rails and a radial-arm saw with long extension tables into a narrow shop. My shop is 10 ft. by 25 ft. and until recently these machines took up most of my

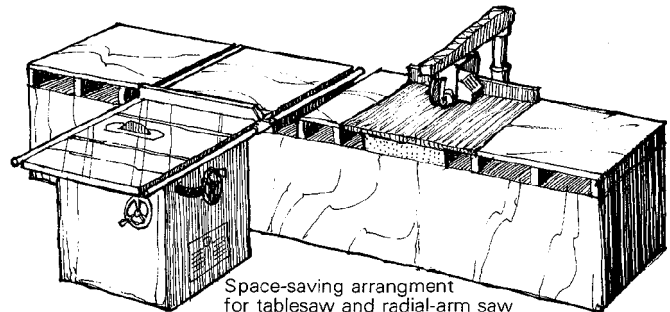

floor space. But by setting the tablesaw at right angles to the radial-arm saw and combining the extension table space of the two machines I was able to recover much of this lost area.

To combine the machines the two tables must be the same height. I chose to block up my radial-arm saw to the height of my tablesaw. Cut two troughs in the radial-arm table to accommodate the tablesaw's rails. Cut the front trough wide enough for the rip-fence lock. Position the rails so that the rip fence rides just a fraction of an inch above the radial-arm saw's table.

—Andrew A. Ruotsala, Seattle, Wash.

Stones and strops from the attic

There have been several good articles on sharpening and honing devices lately, but I haven't seen anybody comment on the old-time water stones that folks used to sharpen their straight razors on. You can sharpen up smaller edged tools with one right smart. They're cheap and available at flea markets, etc., or better yet from older family members or friends. Get ahold of a razor strop too; they work well.

—David Blackley, Matthews, N.C.

Adjustable slot-mortising table

Recently I rescued an old American 16-in. tablesaw from the junkyard. The machine had a slot-mortising chuck on the end

of the arbor and provisions for bolting on a mortising table, which, unfortunately, was missing. So I made a new mortising table using the design principle sketched below. I could

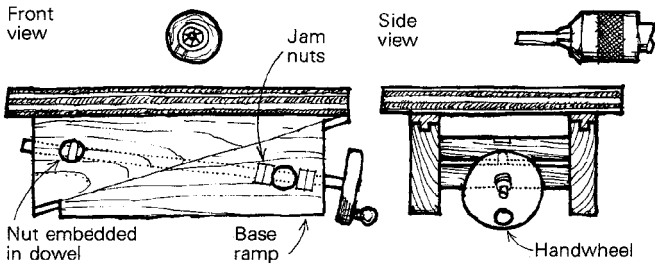

have used a hinged table as featured on several devices in *FWW* recently, but a slanted table just felt clumsy to me.

Here's how the table adjustment works. The threaded rod passes through a hole in the dowel in the base ramp, and is held in place by nuts. As the handwheel is turned, the threaded rod screws into a nut embedded in the dowel in the sliding table, thus ramping the table up on the base. The ramp pieces should be aligned using flanges or a slot-and-rail arrangement.

—Bart Brush, Cherry Valley, N.Y.

Enlarging flute bores

Recently I used a spade bit in a bit extender to enlarge the bore of a wooden flute I was making from $\frac{3}{4}$ in. to $\frac{7}{8}$ in. The method worked so fast and left the bore so smooth I'll use it from now on, even to work the hole size up from the $\frac{3}{8}$ -in. shell auger I start with. A major advantage of the thin shank

is that you don't have to stop so often to remove chips. The secret is to regrind the cutting edge of the spade bit so it will enlarge and follow a pre-drilled hole.

Grind away and taper the corners of the bit so it can enter the smaller hole. Then sharpen one edge (I used a polishing belt on a Dremel sander, followed by a hard Arkansas stone) and relieve the other edge of the bit so that the sharpened edge can cut. The more you relieve it, the deeper the bit will bite. To avoid scoring the inside of the bore as you remove the bit, round the back corners.

—Vasco Pini, Woodstock, N.Y.

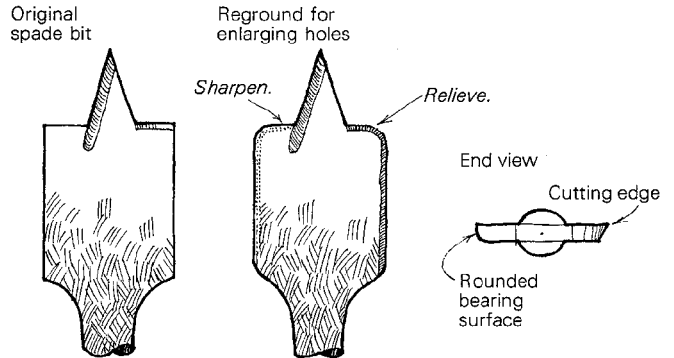

Refurbishing wooden-soled planes

There are hundreds of old wooden-soled Bailey and Sargent planes that, because they're missing blades, chip breakers or cap irons, can be bought for next to nothing. These planes are excellent tools that can be refurbished for a fraction of the

price of a new plane, if one doesn't mind a bit of puttering. The planes come in four widths: $1\frac{3}{4}$ in., $2\frac{1}{8}$ in., $2\frac{3}{8}$ in., and $2\frac{5}{8}$ in. Replacing the blades and cap irons for the $1\frac{3}{4}$ -in. and the $2\frac{3}{8}$ -in. planes is no problem as both sizes are still made by Stanley and Record. Blades and cap irons for the $2\frac{5}{8}$ -in. plane are made only by Record now, but some Stanley blades and caps in this size are available from the Tool Works (111 8th St., New York, N.Y. 10011). The $2\frac{1}{8}$ -in. blade is a problem because no one makes them anymore. Your best bet is to grind the edges off a $2\frac{3}{8}$ -in. blade. A 2-in. cap iron works fine on the $2\frac{1}{8}$ -in. plane.

The major problem, however, is the chip breaker. Both Bailey and Sargent use a "high-hole" breaker, but modern

Blade width	High-hole placement		Cap-iron size
A	B	C	
$1\frac{3}{4}$	$\frac{3}{8}$	4	$1\frac{3}{4}$
$2\frac{1}{8}$	$\frac{1}{2}$	$4\frac{1}{4}$	2
$2\frac{3}{8}$	$\frac{5}{8}$	$4\frac{1}{2}$	$2\frac{3}{8}$
$2\frac{5}{8}$	$\frac{3}{4}$	$4\frac{5}{8}$	$2\frac{5}{8}$

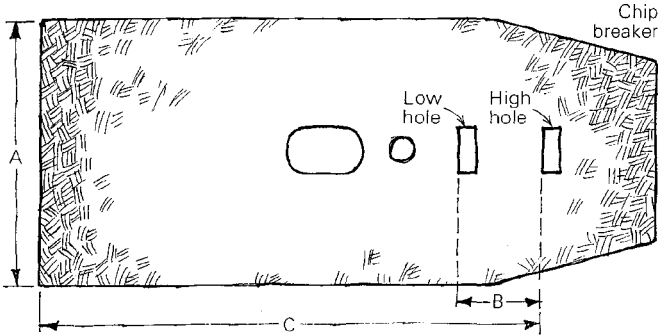

iron planes use a "low-hole" breaker. The two types won't interchange. The answer is to cut a new $\frac{1}{2}$ -in. by $\frac{3}{16}$ -in. slot in a modern "low-hole" breaker to fit the "high-hole" mechanism. The accompanying table shows where to cut the slot.

—Jim McGill, Seattle, Wash.

Router jigs for making molding

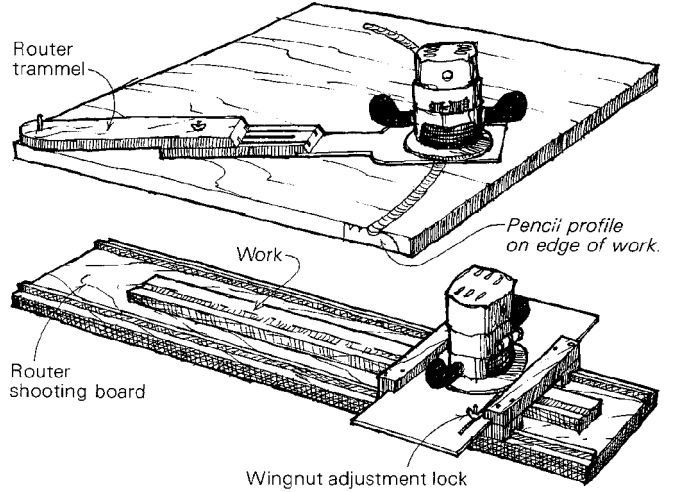

The sketches above show two jigs which, when used with a portable router, can produce both semicircular and straight molding in patterns difficult to produce with a shaper. The first jig is an adjustable router trammel used to make curved

molding. The jig's two-part base adjusts by means of a slot-and-track arrangement and locks with a bolt and wingnut. The router is screwed to a $\frac{1}{4}$ -in. hardboard foot which is, in turn, screwed to the base.

The second jig consists of a sliding adjustable router holder and a "shooting board" which has two parallel tracks. The slotted hardboard in the holder allows the router to be adjusted laterally.

To use these jigs, first pencil the molding profile on the edge of the workpiece. Position the work and the jig so the router is right over the molding. Take repeated cuts adjusting the bit depth, changing bits and adjusting the router's lateral position as needed. When all the routing is complete, separate the curved molding from the waste stock with a bandsaw. Some sanding is necessary to finish the molding.

—S. Gaines Stubbins, Birmingham, Ala.

Constant-angle honing

Most of us know an old-timer who has demonstrated a method of work so effective and simple you wonder why it never occurred to you before. This happened to me recently while honing my plane iron. I was struggling to maintain a constant angle against the stone, lamenting that I did not have one of those fancy roller tools that locks the plane iron at a constant angle while rolling it across the abrasive. Here's the simple solution presented to me.

Slide the chip breaker back from the cutting edge about $\frac{3}{4}$ in. Then lock the double iron in the plane with the blade extending through the throat about $\frac{1}{2}$ in. Now with the heel on the bench top and the plane iron on the stone, slide the plane back and forth. The setup holds the iron at a constant

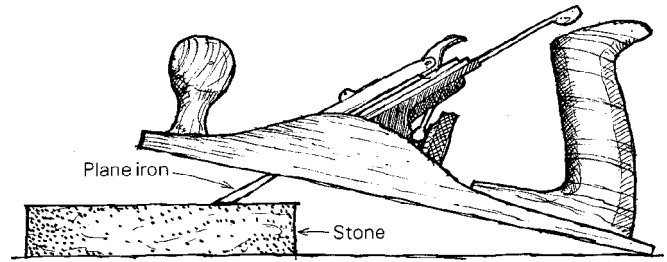

angle to the stone to grind a perfect secondary bevel.

You may have to adjust the setup slightly to fit different-size plane bodies, stones and bevel angles, but the basic idea seems to work with any plane.

—James Vasi, Cheektowaga, N.Y.

Two-level rolling worktable

I made this rolling worktable to ease the logistics of constructing a full set of kitchen cabinets in my small (18-ft. by 18-ft.) workshop. Since then I have found it to be the ideal companion to the traditional cabinetmaker's workbench when space is limited. Built square, level and strong it provides an excellent base for moving cabinets and furniture into or out of the work stream. Or, with the crossbars in place, the worktable can be used at waist height for moving production pieces from machine to machine. As a bonus, it stores away without taking up much room.

Four 360° heavy-duty casters support a 40-in. by 40-in. finger-joined or dovetailed frame of 2x3 hardwood, gusseted with $\frac{3}{4}$ -in. plywood at each corner. Add a couple of 1x3 crossbraces if needed. Screw and glue the $\frac{3}{4}$ -in. plywood top

to the frame, then paint and wax it to make it easy to clean up spilled glue and finishes. Next add two pockets on each of two opposite sides, as shown, to accept the ends of the four hardwood 1x3 uprights. Slot the top of each upright to slip into the two appropriately notched crossbars. These four uprights and two crossbars can be assembled in about 30 seconds to produce a table-height workhorse.

—Norman Odell, Quathiaski Cove, B.C.

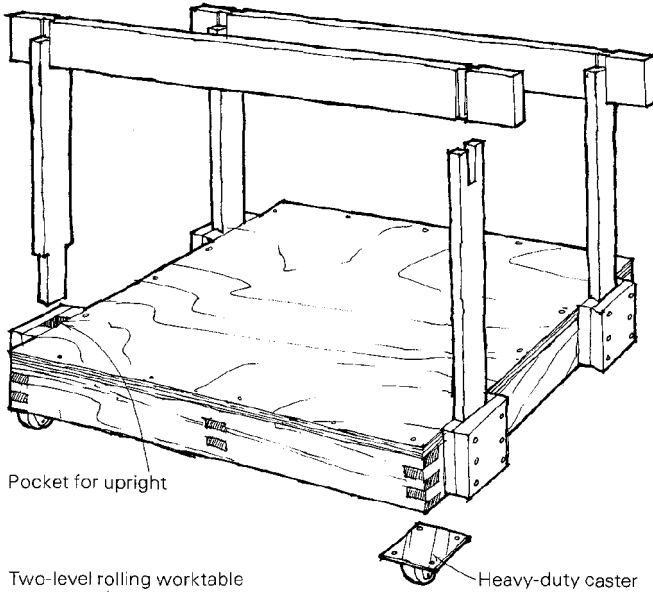

Making stationary tools portable

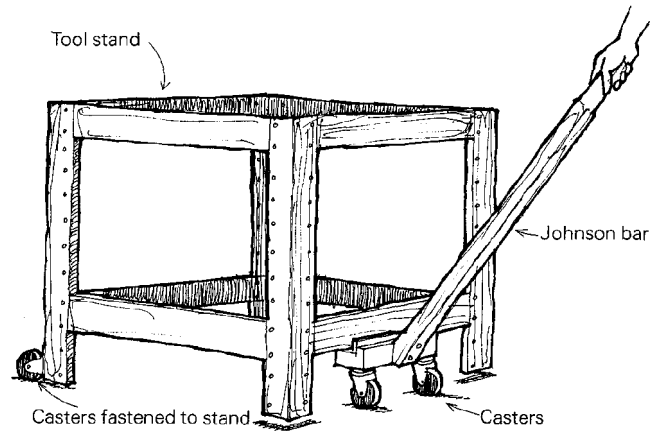

I do my woodworking in the garage, so when I'm through for the day the tools must be moved to make room for the car. For this I use a homemade Johnson bar—a small two-wheel trolley. I made the Johnson bar from heavy-duty casters, a short length of angle iron and a couple of pieces of scrap wood. I insert the trolley under the tool stand, and lever the handle down to jack up the tool stand on its own set of two fixed casters. I can then push or pull the tool to any location I wish. —Jerome A. Jabnke, Milwaukee, Wis.

Methods of Work buys readers' tips, jigs and tricks. Send details, sketches (we'll redraw them) and photos to Methods, Fine Woodworking, Box 355, Newtown, Conn. 06470.

Making wooden toy axles—two methods

When I couldn't find axle pins in the size and length I needed for the wooden toys I make, I devised this lathe tool to make my own. Start with a short length of 1/2-in. drill rod. Drill a 1/4-in. blind hole in the side of the drill rod 3/8 in. from one end. Then drill a 1/4-in. hole through the center. Hacksaw out the center portion to produce a 1/4-in. slot in the end of the rod. File the sides of the slot smooth, then file the bevels on the leading edge of the cutter as shown in the sketch. Put a 1/2-in. setscrew collar over the cutter and tighten it up. Without the collar the cutter would open up in use.

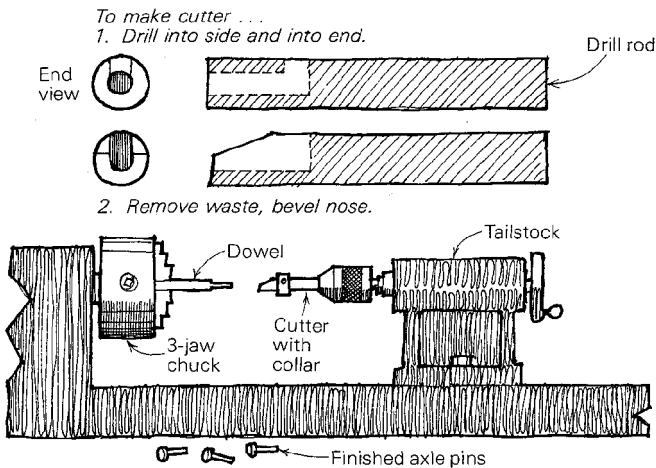

I chuck the cutter in the tailstock and adjust the tailstock clamp so it will slide smoothly on the lathe bed. I use 3/16-in. dowel stock for the axle pins which I feed through the headstock and hold with a three-jaw chuck. To cut the pin I push the tailstock cutter against the dowel until I have the length pin I need. I then cut off the pin, starting with a fine-tooth saw, rounding off the face with a file and then completing the cut-off with the saw. —Stanford LeGath, Clifton, N.J.

A few days before my daughter's birthday, I discovered I was out of the little axle pins necessary to fasten wheels to the toy train I was building for her. Then I hit on a simple tool that produces pins in abundance. It took only a couple of hours to make, and it freed me from the two-week mail-order delay.

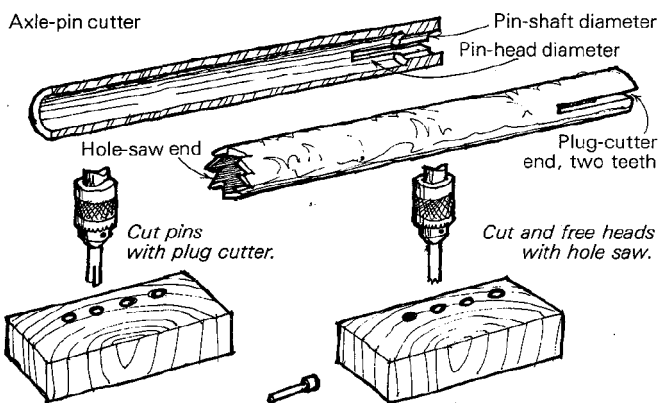

The tool is a short steel bar that's a plug cutter on one end and a hole saw on the other. Each end is used in turn—first the plug cutter to make the shaft of the pin and then the saw end to free the pin head. To make the tool, start with a 3-in. long section of 1/2-in. drill rod or round tool steel. Drill a 1/4-in.

hole through the length, making a tube. Next, enlarge the hole to 3/8 in., stopping about 1/4 in. from one end. To make the hole-saw end, file eight deep teeth into the wide end of the tube with a triangular file. To make the plug-cutter end, simply saw a 1/8-in. slot 1 in. into the narrow end of the tube. The slot will allow sawdust to escape. Cut two teeth into this end of the cutter, one on each slot. To finish the tool, dress and sharpen all the teeth, then harden and temper the steel.

To make axle pins, first cut an end-grain block of hardwood a little longer than the pins need to be, 1/16 in. or so. Chuck the tool in the drill press, and using the plug-cutter end, cut all pin shafts in the block. You will likely have to back the cutter out of the hole occasionally to clear chips. When done, reverse the tool and cut the pin heads following each hole. Dress each pin head by chucking the pin in the drill press and filing the head to the desired shape.

—Robert F. Vernon, Keuka Park, N.Y.

Making louvers

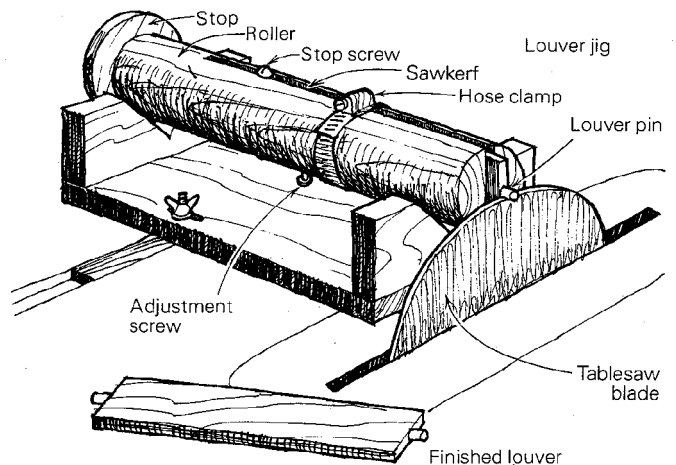

This simple jig cuts the pins on the ends of the individual louvers in homemade louvered doors. It consists of a V-notched base, which slides in the tablesaw's miter-gauge track, and a cylindrical louver holder. A slot in the cylinder holds the louvers in the correct cutting position, using adjustment and stop screws as shown in the sketch. To use the jig, load a louver blank into the cylinder, then tighten a hose clamp around the cylinder to lock the louver in place. Place the cylinder in the base, push the jig into the blade and rotate the cylinder to cut a pin on one end of the louver. Remove the louver, reverse it in the cylinder and repeat to cut the other end's pin. —R.F. Paakkonen, Stafford Springs, Conn.

Shading marquetry veneer

Sand-scorching has been used in marquetry for years to achieve the subtle shades needed to show shadows, curvature and depth. The standard procedure calls for either dipping the veneer into a hot sand bath or spooning the hot sand onto the veneer in repeated steps to gradually shade the area. Recently I discovered a direct-scorching technique that proved quite successful. I used a miniature 5-in. butane torch (available from Microflame, Inc., 3724 Oregon Ave., Minneapolis, Minn. 55246). The secret is to use unheated sand to mask the area to be scorched. I carefully line each shadow area with a layer of sand, leaving no area that I want to remain light-toned uncovered. I slowly warm and shade the exposed areas with the torch to create the appearance of gentle curves or dimples. The sand acts as a deflection shield to repel heat in

proportion to the amount of sand piled up on the unexposed area. When I need to show a sharp hard-edged shadow, I cut into the veneer along the edge of the shadow, dip a thin metal heat shield into the cut and scorch the exposed veneer. Great care must be taken with open-edged pieces because they burn readily, and shrinkage is a certainty. To expand shrunken pieces I wipe on a solution of equal parts water, white glue and glycerine. This solution usually returns the piece to its original size.

—Martin R. Zschoche, Vista, Calif.

Making sectional molding

Sectional molding for cabinet doors is easy to make on the tablesaw and lathe. Cut the straight sections on the tablesaw with a molding head. To make the semicircular section at each corner, remove the cutter from the molding head and bolt it to a heavy strap-iron handle. This provides a scraping tool for shaping a circle on the lathe's faceplate. Separate the molding from the waste wood with a parting chisel. Then cut each of the four corner sections from the circle at the proper miter angle.

—Duane Waskow, Cedar Rapids, Iowa

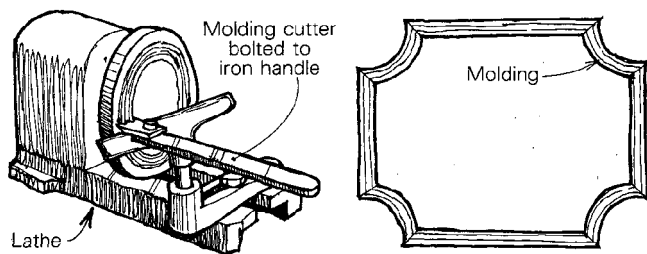

Door bumpers from cue tips

Replacement leather tips for pool cues make excellent bumpers for sliding and swinging doors on projects. They do a fine job of quieting and cushioning the doors when they are slammed, and they are certainly better looking than the black rubber bumpers that are commonly available. The tips, which can be bought at sporting goods suppliers, have a threaded brass shank for fastening to the cue. To install the tips on a project, drill a slightly undersize hole and use a hammer to tap the threaded shank into the hole. The threads hold like ring nails, and all that shows is leather.

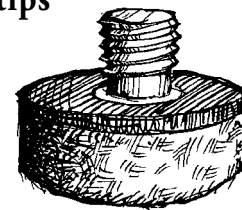

—C. W. Moran, Larchmont, N.Y.

Homemade scraper plane

The cabinet scraper sets the standard of excellence for smoothing wood, but it has some drawbacks: tired, blistered fingers (these things get hot!) and uneven surfaces. Scraper planes are available, but the most common one (which resembles a large iron spokeshave) has such a short sole that it is difficult to control and often chatters.

With these thoughts in mind I decided to make a simple wooden scraper plane. It went together in only a couple of hours and proved to be quite successful.

The body of the plane is laminated from three pieces of wood as shown in the illustration [p. 20]. The block against which the blade bears must be dished slightly to spring the blade into a curve. The back of the wedge must be correspondingly convex. This curve should be roughly $\frac{1}{32}$ in. across

a 2½-in. wide throat. The wedge must fit accurately and should extend through the body nearly to the sole. The support provided by the wedge, the curve of the blade and the length of the plane combine to prevent chattering.

A scraper plane is useless unless the blade is properly sharpened. To sharpen, joint the edge with a file, then bevel the edge on a stone to a 45° angle. Hone the edge just as you would a plane iron. Then with a burnisher or hard steel rod, rub back and forth. At first hold the burnisher parallel to the bevel, then gradually tilt it until it is perpendicular to the blade. This technique produces a razor-sharp curl every time.

—Bradley C. Blake, Redwood, Miss.

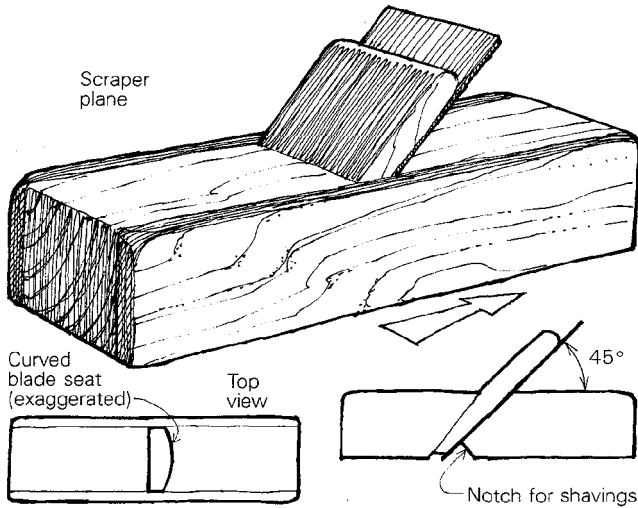

Hold-in improvement #1

Fingerboards perform much more effectively if you screw them to tapped holes in the saw table rather than clamping them. Clamped fingerboards don't lie flat, and they can slip and lose pressure against the work.

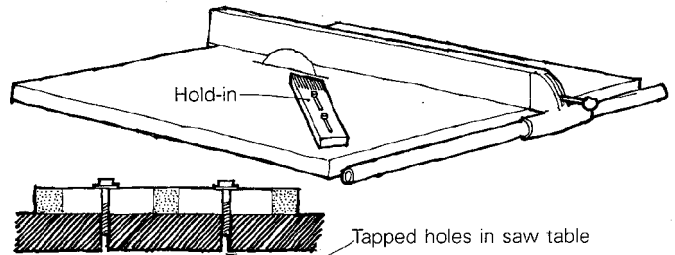

To make the fingerboard, saw kerfs ½ in. or so apart in the end of an angled 1x3. Rout two ¼-in. slots down the centerline of the fingerboard—one at the head, one at the tail. Now set the fingerboard in position on the saw, so it will exert pressure just ahead of the blade, and mark the center of each slot on the saw table with a punch. Drill and tap holes into the table at these points. Lock the unit in place with cap screws or bolts threaded into the tapped holes.

—Ben Erickson, Eutatw, Ala.

Hold-in improvement #2

The molding head for the tablesaw is a valuable tool. But without the proper hold-ins it is practically impossible to shape thin stock without chattering. The hold-in fixtures I use to overcome this handicap consist of an auxiliary fence and a

horizontal hold-in. The auxiliary fence is a maple 1x3 that screws to the saw's rip fence. Since this fence may cover part of the rotating cutterhead, it's a good idea to cut a recess into the fence beforehand by raising the cutterhead into the fence. The top of the fence is fitted with an adjustable pressure shoe that holds the work to the saw table.

Make the pressure shoe from a stick of maple by sawing two (or more) sawkerfs from opposite ends. This gives the shoe some spring, allowing it to adjust to minor variations in thickness and to damp out any chattering.

The horizontal hold-in is simply a slotted arm fitted with another pressure shoe. It holds the work firmly against the fence. The arm, locks in place with cap screws that fit tapped holes in the table.

Design the fence and hold-in so you can reverse them and use them on either side of the saw's rip fence. This will allow you to take full advantage of both left-hand and right-hand cutter designs. —Walter O. Menning, LaSalle, Ill.

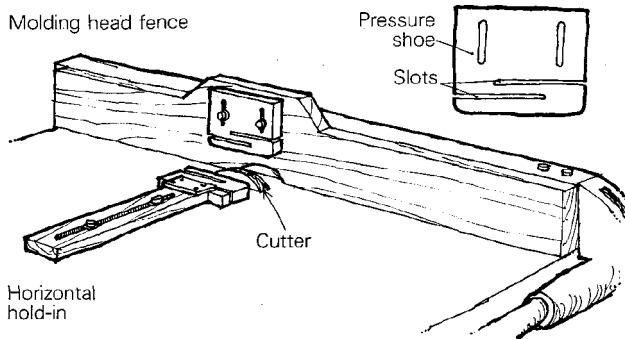

Mini-drawknife

This mini-drawknife is as small and handy as a spokeshave but can slice away a good deal of wood on each draw. It is great for getting in close to the bench and for use in tight quarters where neither of its brothers could perform.

To make the tool, start with an old 6-in. jointer knife and slowly grind the handle tangs as shown in the illustration. Grind the tangs at a slight angle back from the cutting edge so that the handles wedge on the tangs and stay tight when the tool is pulled. Turn the handles to any comfortable shape, and fit the tangs. For a perfect fit, glue up the handle blanks with paper between. Turn, split apart, and groove each half to fit the tang. Then glue the halves together.

—Jim Clark Jr., Bridgeville, Penn.

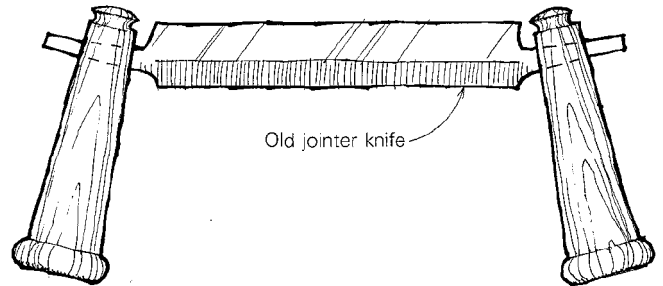

Solution to tear-out problems

If your planer or jointer tears out crossgrained wood, sponge on a light coat of water. The water swells and softens the fibers, packing them tight together to give the cutting edge a little more to push against. Where the grain is steep, more

water is absorbed—just where you need it. After applying a light coat of water, wait a minute and take a light cut. If the grain tears out, add more water and let it soak in longer. Since most of the wet wood is planed away, there is little chance of warping the wood.

This trick works best with hardwoods but is occasionally successful with softer woods. Tear-out problems in hand-planing also respond to this treatment, but you must wait until the surface is completely dry before scraping.

—John Leeke, Sandford, Maine

Auxiliary shop-vac tank

For sawdust collection I use a couple of Sears shop-vacs that I connect to my tools through normal methods. But by using auxiliary dust-collection tanks, I'm able to stretch the filter-cleaning cycle considerably. To make the tank, start with a

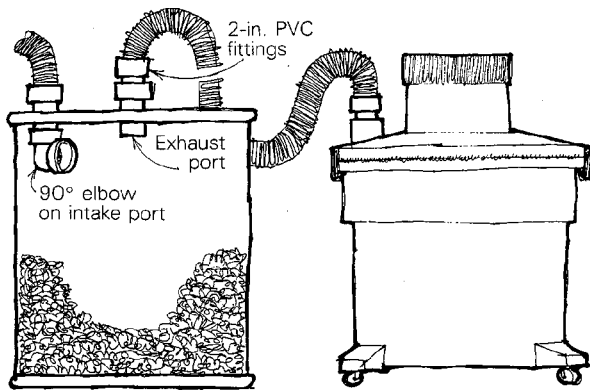

55-gal. drum or a fiber barrel (the kind with the removable clamp-on lid works well), and install 2-in. PVC pipe intake and exhaust ports as shown in the sketch. The 90° elbow on the intake port sets up a cyclone action that drops dust and chips at the perimeter and bottom of the tank. You can fill the auxiliary tank to the elbow and still have the vacuum filter open and breathing.

The 2-in. PVC pipe fittings fit the standard flexible hose ends commonly used on shop-vacs, increasing their versatility and hook-up options. —D.J. Greenwald, Hudson, Wis.

Spreading glue with a pad painter

The pad painters sold for painting trim are excellent glue spreaders. Their short fibers and stiff backing let you apply a smooth coat of glue faster than with a brush. Dip the pad into a shallow pan of glue or just use the pad to spread glue straight from the bottle. —Chuck Lakin, Waterville, Maine

EDITOR'S NOTE: Contributing editor Tage Frid has offered a couple of observations about Robert Thomason's wooden bending blanket method (*FWW* #32, Jan. 1982, p. 20). Whereas Thomason used tapered keys to align the top and bottom parts of his laminating form, Frid suggests using straight keys. With straight keys the top and bottom are in alignment from the moment the form starts together. Frid also points out the importance of using sticks in the bending blanket that are all exactly the same thickness. Thickness-plane the stock first, then rip the sticks. Use the thickness dimension for the top and bottom of the blanket. —Jim Richey

Methods of Work buys readers' tips, jigs and tricks. Send details, sketches (we'll redraw them) and photos to *Methods*, Fine Woodworking, Box 355, Newtown, Conn. 06470.

Thickness-sander attachment for lathe

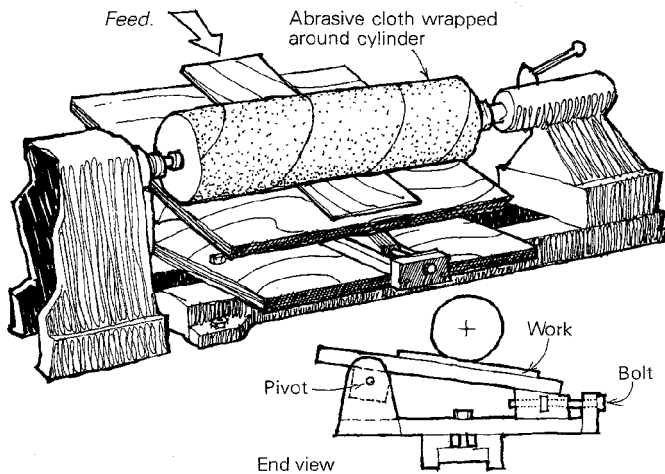

The sketch above shows the thickness-sander lathe attachment I made to sand dulcimer tops and sides. The design is similar to the sanders shown in *FWW* #21, p. 50, but because the device uses the lathe's motor, spindle and bed, it is much easier to make. By using the lathe's variable-speed pulleys you can always find the perfect sanding speed. The sanding drum is simply a turned wooden cylinder spirally wrapped with abrasive cloth. The plywood and hardwood base bolts to the lathe bed and adjusts with a simple wedge mechanism.

—Charles R. Adams, Westmoreland, N.H.

Thickness-sanding on the belt sander

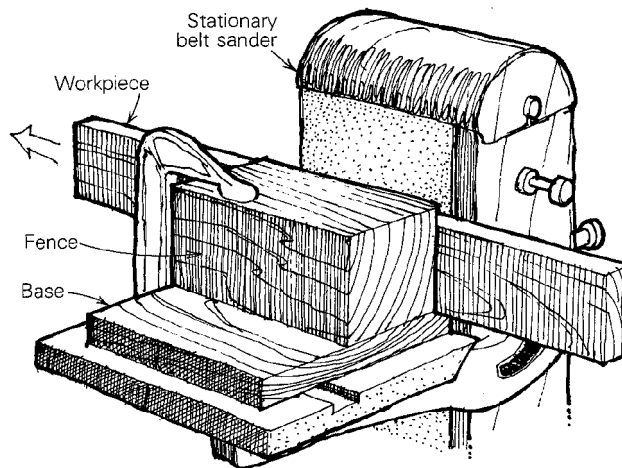

Lacking a commercial thickness sander, I use my standard 6-in. stationary belt sander as shown to face-sand thin strips of re-sawn stock. The base of the fixture touches the sanding belt. The fence is slightly angled, to provide a wedging effect for pressure. Cross-grain sanding removes wood fast, and the work can't kick back—William B. Allard, Tacoma, Wash.

Circle guide for the router

This fixture for routing circles has several advantages over commercial circle guides: it's cheaper, it cuts circles smaller than the router base and it allows repeat set-ups to precise radii without trial and error.

The guide is easy to make. Screw a piece of 1/4-in. plywood to the base of your router, carefully countersinking the screws. The plywood should be as wide as your router base and

somewhat longer than the largest radius you intend to cut. Saw or drill a clearance hole for the router bit.

Let's say you need a 4-in. radius circle. Measure from the edge of the bit out 4 in. and drill a small hole at that point. Insert a brad in the hole, point up, to serve as a pivot. Drill a centerhole in a piece of scrap, place it on the guide, rout a short arc and measure the radius produced. You'll be lucky if it is right the first time. Regardless, label that hole with whatever radius it produces, say, 4 1/16 in. Then make another hole closer or farther, as the case may be, until you get the radius you want. Remember to mark each hole as you go.

Since the markings are accurate for only that particular bit, you can divide the guide into sections and head each group of holes with the bit used—1/2-in. straight, for example.

—Brian J. Bill, Old Bridge, N.J.

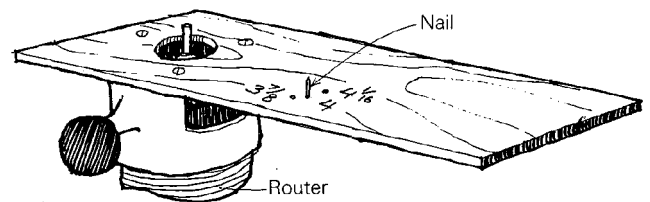

Bending wood without steam

Here's how to bend wood using a solution of hot water and Downey fabric softener. First build a container of black 6-in. ABS pipe by cementing a cap on one end and putting a removable cap on the other. Don't try regular PVC pipe; it won't hold up to high temperatures. The length of pipe can be whatever fits your need.

Mix one part Downey to twelve parts water, and heat the solution to boiling. Put the wood to be bent in the container and pour in the hot solution. Seal the open end of the container. It is important to keep the container warm. Here in California, I set the pipe out in the sun. On cloudy days I've sat the pipe next to a mirror and heated it with sunlamps. Leave the wood in the hot solution for a minimum of one hour. You'll find that wood softened in this solution will hold its shape better and not snap in the bending process. The solution turns thin wood to spaghetti.

—David Ferguson, San Clemente, Calif.

Finishing toy wheels

To smooth rim:

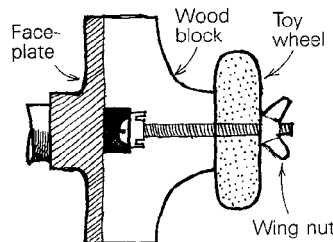

To turn side:

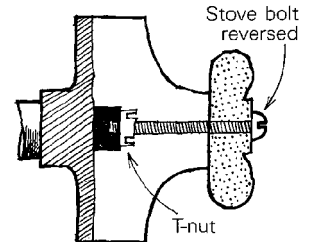

To finish wooden toy wheels on the lathe, I use a simple fixture similar to the one described by George Pilling (*FWW* #30, p. 16). After I cut the blanks using a hole saw with a 1/4-in. pilot bit, I mount the blank on a special wooden faceplate in one of two ways, depending on the work to be done. If I'm smoothing the rim, I install a 1/4-in. bolt through the fixture from the back, slide the blank on the protruding threaded shank and fasten the blank in place with a wing nut, for quick changes.

On the other hand, if I'm turning the face of the wheel, I

remove the bolt from the back and screw the blank to the fixture from the front, which allows more room. A T-nut installed in the back side of the fixture anchors the bolt. To save time, do one operation on all the wheels before reversing the bolt. —*Carlton M. Herman, Hendersonville, N.C.*

Homemade bench vise

Unless you're lucky enough to own a European workbench with well-designed, sturdy vises, you are likely relying on inadequate ways of holding your work. Trouble is, most of the commercially available wood vises are just too small. And it is awkward to hold workpieces vertically because the center screw is in the way.

My alternative to the commercial vises is shown in the sketch below. It is a simple, inexpensive, effective means of

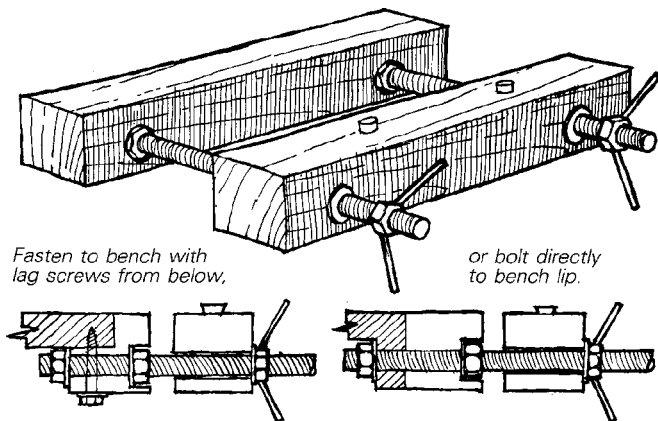

keeping work where I want it. At first the two wing-nut vise screws might appear to be inconvenient, but in most cases you can hold narrow stock by tightening only one screw. In fact, because of the independent movement allowed by two screws, it is routine to secure work with non-parallel sides.

The feature that has been most useful is the ability to hold panels up to 17 in. wide in a vertical position right down to the floor. This feature is invaluable for planing end grain and cutting dovetails and tenons.

I made my vise from two 24-in. lengths of 4x4 scrap hardwood, salvaged from a freight skid, and two 19-in. long sections of 1-in. threaded rod with matching nuts and washers. A friend spot-welded the wing handles on two of the nuts. You could epoxy the nuts into wooden wings instead. Be sure to angle the handles away from the jaw.

Drill 1-in. holes in the rear jaw, but drill $1\frac{3}{16}$ -in. holes in the front jaws to allow for free jaw movement. Be sure to align the holes properly. I clamped both jaws together and drilled through one jaw, allowing the tip of my drill bit to register the hole in the other jaw.

—*Joe Loverti, Miamisburg, Ohio*

Two hot-glue gun tips

A common technique for attaching a turning blank to a faceplate to avoid screw holes is to glue the blank to a waste board with paper in between. The method works well, but the long curing time of the glue is inconvenient.

I have found that a hot-melt glue gun will attach the blank to the waste board rapidly and securely. The glue sets in about 15 seconds, so no clamps are needed—just hand pressure. No paper is needed because the glue bond can be

Methods of Work (continued)

easily broken later with a chisel. Since the glue doesn't become hard, cleanup of the bottom of the turning is easy.

—*John Foote, Clarksville, Tenn.*

When I am bandsawing complex shapes where material must be removed from two or three sides, I use hot-melt glue to temporarily reattach the discards to stabilize the piece during further sawing. The hot-melt glue is superior to tacks or tape in this application. It's very fast and it just takes a couple of dabs here and there to hold the discard in place. Later you can easily pry or strike the waste piece off.

—*J.A. Spratt, Smithville, Ont.*

Veneering with sandbags

The easiest way to apply even pressure on veneer being glued to a curved surface such as a serpentine drawer front is to use several pillow sacks filled with sand. Store the sandbags near the stove. Their warmth will shorten the glue-curing time.

—*Granton James, El Paso, Tex.*

Auxiliary tailstock for boring

To bore holes through lamp bases and similar turned items, I made an auxiliary tailstock to hold the work so I could pass a long drill bit through the regular tailstock. The key feature of this special tailstock is the bearing from a bicycle crank hanger. This bearing has a 1-in. bore, so I turn a 1-in. tenon on the end of my lamps to fit it. The rest of the device consists of a ¼-in. thick aluminum-plate upright, a short section of a 1-in. angle-iron base to span the lathe ways, and a wooden dog, which tightens under the ways to lock the unit in place. To keep wood chips out of the bearing, I turned a cover for

the bearing that also holds the bearing in the upright.

In use, the ram from the tailstock is removed and the drill bit is passed through the tailstock into the lamp, which is supported in the auxiliary tailstock.

—*Ralph Luman, Virginia Beach, Va.*

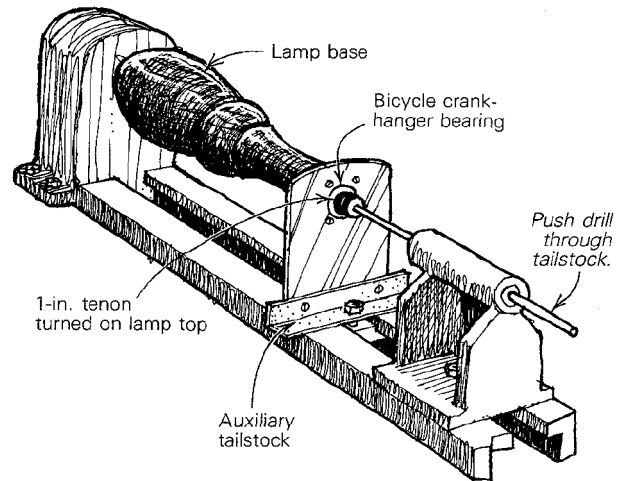

Pin router attachment

By bolting a simple router arm and an auxiliary table to my drill press, I can convert it to a pin router. This lets me take advantage of the drill press' quill movement to lower the router into the work. Make the router arm from a 20-in. length of 2x6 lumber. Drill the arm to fit your drill-press quill and feed stop, then notch the back of the arm so it can

slide up and down the post. On my drill press the arm is held in place well enough by the drill-press feed-stop collar and the feed stop. Other drill presses might require bolting the arm directly to the housing. In the end of the arm, cut a hole the same size as your router. Then cut a slot in the arm and install a bolt to pinch the router and lock it in place.

The table is a 20x30 panel of 3/4-in. plywood covered with plastic laminate and strengthened by a thick plywood spine on the bottom. A tapped brass plate located in the center of the table accepts different diameter pins (I used standard router pins from Sears).

—Andrew Makarevich, Villa Park, Ill.

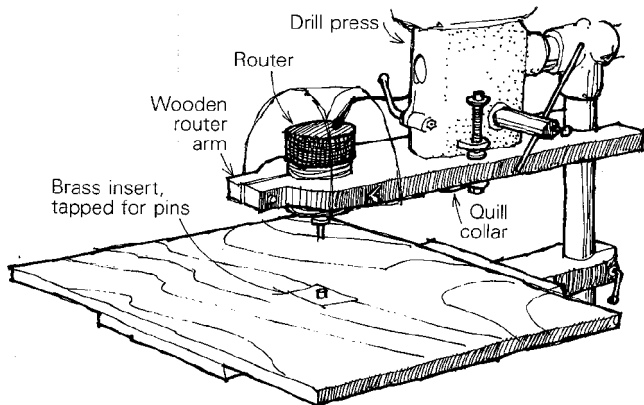

Planing stand

To hold boat planks and decking for planing and beading, we use what must be the world's simplest workbench. It con-

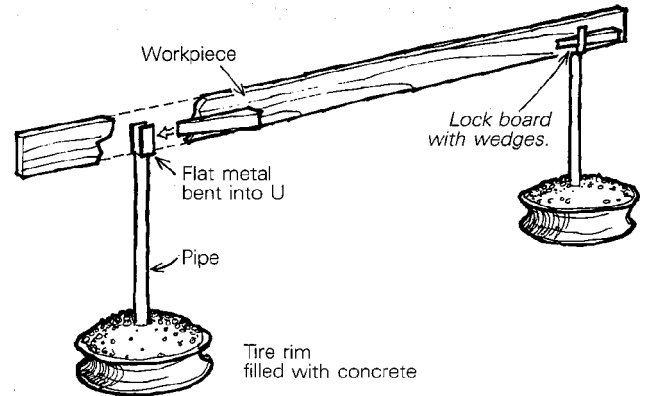

sists of two stands made from concrete-filled wheel rims, some 1 1/2-in. pipe, a couple of pieces of flat steel bent into U-shape, and a couple of wedges. The stands are very stable (approximately 150 lb. each), yet they can be easily tilted and rolled wherever needed. One advantage of the stands is that you can work a plank from both sides—there's nothing in your way anywhere.

—Kim Aaboe, Halifax, N.S.

Veneering convex workpieces

Here is an alternative to a custom-fitted caul for veneering curved work. The device will cope with a wide range of convex forms, is quickly made in any size and requires much less material and construction effort than a specially shaped caul.

Take a piece of hardwood slightly longer than but not quite as wide as the item to be veneered. Tap the board for wooden screws to provide pressure along the midline at

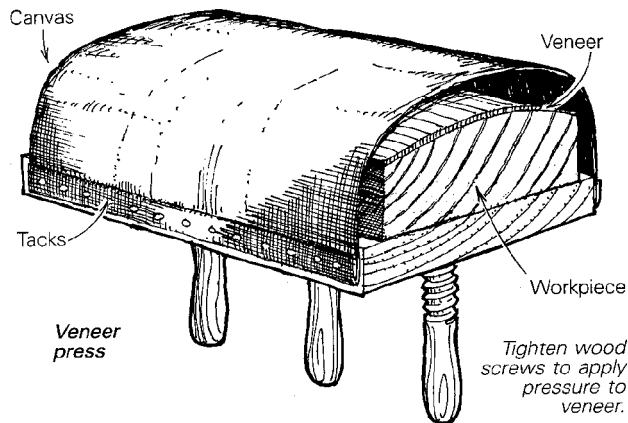

about 6-in. centers. (You could use wedges or threaded rods and nuts if you have no threading tools.) Tack a strip of stout canvas along both edges to form a tube as shown in the illustration. Place the veneered workpiece in the tube and tighten the screws. A glance at the open ends will show when the tube is taut and has clamped the veneer against the base. Put aside to dry. Tubes of various sizes can be built up sharing the same wooden screws.

—R.W. Shillitoe, Ilkley, West Yorkshire, England

Portable benches

Shown at right are two valuable additions to my shop. The sawhorse on the left is fitted with a small bench vise. I keep small power tools in the tray, and store hand tools in the drawers below. Because of the three legs and the extra weight

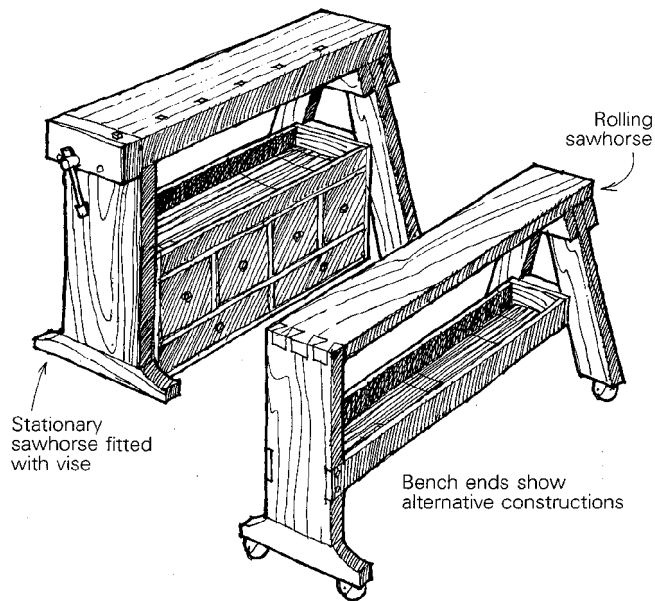

the horse is very stable. A short board can be clamped between the dogs. For longer work, the caster-fitted second horse rolls easily into position to support the distant end.

—S. Grandstaff, Happy Camp, Calif.

Methods of Work buys readers' tips, jigs and tricks. Send details, sketches (we'll redraw them) and photos to *Methods*, Fine Woodworking, Box 355, Newtown, Conn. 06470.

Circle division table

During my forty years as a modelmaker, I have used this circle division table many times. I know of no faster method to divide a circle into several equal parts. To use the table, just pick the number of divisions you want from the 'No. of spaces' column. Multiply the selected 'Length of chord' times the diameter of your circle and set a divider to this reading. Then simply walk the dividers around the circle, marking each point. If you're working with small circles, it helps to have a rule divided in hundredths to set the dividers accurately.

—Ray Elam, Los Gatos, Calif.

No. of spaces	Length of chord	No. of spaces	Length of chord	No. of spaces	Length of chord	No. of spaces	Length of chord
3	0.8660	28	0.1120	53	0.0592	78	0.0403
4	0.7071	29	0.1081	54	0.0581	79	0.0398
5	0.5878	30	0.1045	55	0.0571	80	0.0393
6	0.5000	31	0.1012	56	0.0561	81	0.0388
7	0.4339	32	0.0980	57	0.0551	82	0.0383
8	0.3827	33	0.0951	58	0.0541	83	0.0378
9	0.3420	34	0.0923	59	0.0532	84	0.0374
10	0.3090	35	0.0896	60	0.0523	85	0.0370
11	0.2818	36	0.0872	61	0.0515	86	0.0365
12	0.2588	37	0.0848	62	0.0507	87	0.0361
13	0.2393	38	0.0826	63	0.0499	88	0.0357
14	0.2224	39	0.0805	64	0.0491	89	0.0353
15	0.2079	40	0.0785	65	0.0483	90	0.0349
16	0.1951	41	0.0765	66	0.0476	91	0.0345
17	0.1837	42	0.0747	67	0.0469	92	0.0341
18	0.1736	43	0.0730	68	0.0462	93	0.0338
19	0.1645	44	0.0713	69	0.0455	94	0.0334
20	0.1564	45	0.0698	70	0.0449	95	0.0331
21	0.1490	46	0.0682	71	0.0442	96	0.0327
22	0.1423	47	0.0668	72	0.0436	97	0.0324
23	0.1362	48	0.0654	73	0.0430	98	0.0321
24	0.1305	49	0.0641	74	0.0424	99	0.0317
25	0.1253	50	0.0628	75	0.0419	100	0.0314
26	0.1205	51	0.0616	76	0.0413		
27	0.1161	52	0.0604	77	0.0408		

These figures are for a 1-in. diameter circle. For other sizes, multiply length of chord by diameter of circle desired.

Shaving horse #1

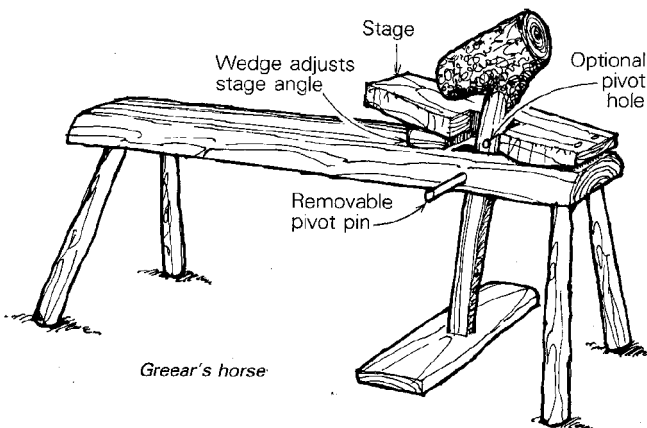

The design of this dumbhead shaving horse, suited to working both long and thick stock, was handed down to me by some old-timers. It is made mostly from oak timbers and can be completed in a couple of days.

First split and hew a 5-ft. long, red oak log sap-side-up for the top of the bench. The heart side of a split log is harder to

working platform) from a 3-ft. long, split oak log, and peg or bolt it to the bench at the far end. Taper the width of the stage toward the front (about 4 in.) so that the handles of the drawknife—and your fingers—have good clearance. Belly the underside of the stage in front of the pins and support its front edge with a wedge, so you can vary the working angle of the stage.

The "dumbhead" is a short section of hickory trunk with 3 ft. of limb left attached to act as a lever. Cut a mortise in the right side of the stage and hew the branch to fit it, being sure to flatten the limb at an angle so that the trunk section aligns over the stage. The fulcrum is a removable peg—you can make a series of pivot holes to adjust the horse for the thickness of your stock. Tusk-tenon a large pedal to the end of the limb.

This design is for right-handed people. Long pieces of wood, such as shovel handles, are positioned to the left of the dumbhead lever and pass comfortably under the shaver's right arm. A left-handed person would want to move the mortise for the dumbhead lever to the left side.

—Delbert Greear, Sautee, Ga.

Shaving horse #2

To make a shaving horse quickly with a chainsaw and broad ax, select a 6-ft. long hardwood log, 8 in. to 10 in. at the butt. Snap parallel lines down the log, halving the circumference. Saw kerfs down to the snap lines every 3 in. or 4 in., stopping 2 ft. from the butt end. Hew the chips out with the broad ax. Next hew out the remaining 2 ft. to act as a stage, angling it and tapering it as shown—the front of the work

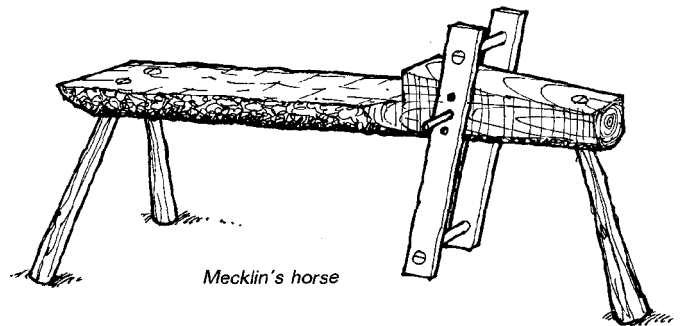

area should be less than 6 in. wide, to clear the drawknife handles. Make three 2-ft. long legs, and mortise them into the bench at an angle for stability. Now you have the basic work area shaped. It can be smoothed with adze or plane. Spend time on the work area to ensure that it is flat and true.

Traditionally, the head extends through a mortise in the work area. However, I prefer the "ladder-rung" head shown. With this setup you can work a long piece of wood unencumbered by the neck of the traditional head. Also, the ladder-rung head holds larger pieces of wood. Make the head out of two 2-ft. long 1x3s and two 1-in. dowels glued and wedged in the 1x3s. The head pivots on a 3/8-in. linchpin through the bench. Drill additional holes in the 1x3s as you experiment with the horse. If you wish, add a more elaborate pedal to the bottom of the head frame. Now you're ready to make excellent kindling. —John Mecklin, Cherryfield, Me.

Self-locking bench dog

Pendleton Tompkins' horizontal vise (*FWW* #28, p. 28) was an excellent suggestion. In fact, I made two vises and use them frequently to hold large pieces of plywood. However, I did not want to go to the expense and bother of installing a

bench-screw nut to the bottom of every bench-dog hole. I solved my problem by making a pair of self-locking bench dogs as shown below.

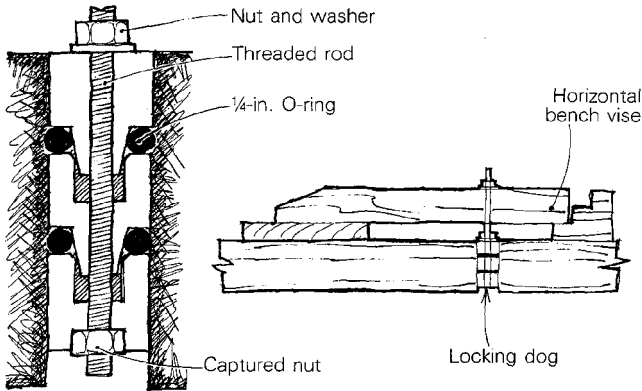

To use the dog, I drop it into a dog hole and tighten the nut on top to compress the O-rings and make them bear against the side of the dog hole. Then I place a vise jaw over the threaded rod and tighten it in place with another hex nut. The O-rings provide enough friction so that the bench dog does not slip up as the vise is tightened.

—William A. Rolke, Ft. Lauderdale, Fla.

Portable sawhorse

This sawhorse design doesn't look very strong, but it will stand up to all but the most demanding jobs. Because they are light and fold flat, the horses are perfect to take along to

the job site. You'll wonder how you put up with those awkward 2x4 sawhorses for so long.

I used white pine for all parts, and doweled the joints. You could certainly make a stronger horse by using oak or maple and joining parts with mortise and tenon. After three years of service, however, my dowel joints are still tight. Make sure the hinges don't stick up above the top rail of the sawhorse, and be careful not to cut into the hinges when you work.

—Brad Schwartz, Huntington Beach, Calif.

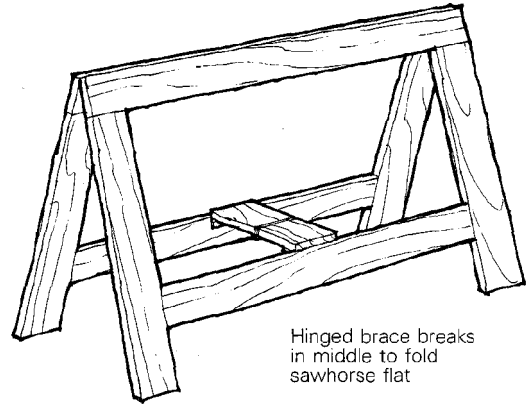

Improved tusk-tenon joint for bed frame

The traditional tusk-tenon joint is well suited to joining bed side rails to headboard and footboard in all respects save one—the protruding parts are real shin-kickers. To overcome this problem, I designed an internally wedged joint which is no more difficult to make and works quite well. From the

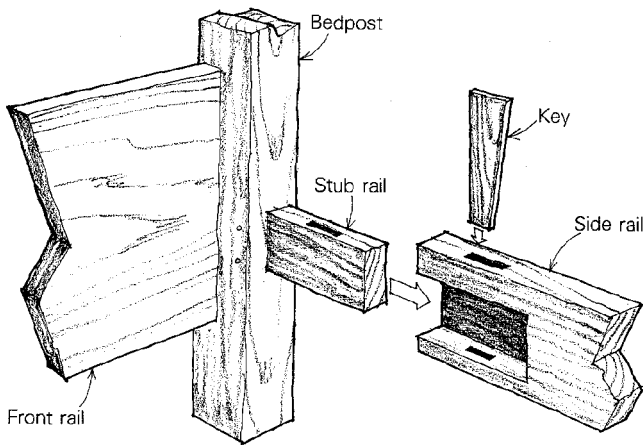

outside you see only the ends of the key. The secret of the joint is a stub rail mortised into the bedpost, pinned through the cheeks for strength. The stub rail fits into a short slot cut in the back of the bed's side rail. There it is locked in place by a key driven in from the top.

—Stefan During, Texel, Holland

Sharpening a wire wheel

If you use a wire wheel to remove rust from old tools, you know how soon the bristles bend over and lose effectiveness. Reversing the wheel helps, but just before you do this, run the wheel against a coarse grindstone. This puts a chisel edge on the wires that really cuts fast.

—Mark A. Latour, Saint John, N.B., Canada

Centerfinder for woodturners

This Plexiglas centerfinder will be useful to woodturners who split odd-shaped workpieces from the log. To make the gauge, first mount a piece of scrap wood to the faceplate and trim it to a round disc. Now attach a piece of 3/8-in. thick clear Plexiglas to the scrap-wood disc and scribe a series of target-like circles into the face of the Plexiglas through its protective paper. Drill a center hole to fit your favorite scratch awl. To complete the gauge, spray the grooves with a colored enamel, drill a hang-up hole in one corner and remove the paper. To use the gauge, hold it on the end of irregular stock and adjust it until the largest possible circle falls completely over wood. Then mark the center.

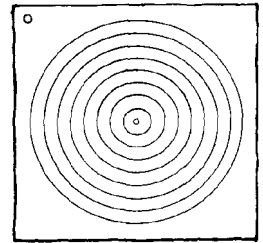

—Nels Thogerson, Ames, Iowa

Hand drill

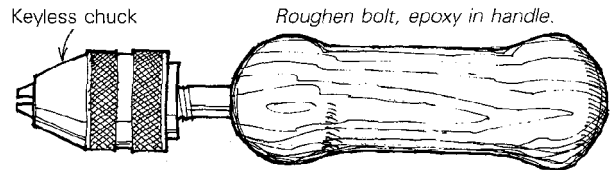

I made this tool ten years ago for holding cut-off Alien wrenches. Since then I've found several other uses for it and I use it often in my workshop. I haven't seen a hand drill this

size available commercially, but it is easy to make. Smaller versions are available as pin vises. Some uses are:

- a holder for sharpening small drill bits.
- a handle for needle files.
- a leather or scratch awl (chuck a sharpened nail).
- a handle for hex screwdriver bits.
- deburring wood or metal holes (chuck a countersink).

And, in its primary use as a hand drill, for a few shallow holes it is easier to use than a power drill.

—Robert J. Harrigan, Cincinnati, Ohio

Disposable foam brush



I use this homemade foam brush with its disposable insert on those little oil-finish or paint jobs where it is more work to clean a brush than to do the job.

I fold 1/2-in. thick foam carpet padding around the end of a 1/32-in. aluminum stiffening strip, and clamp it with a rubber band in an aluminum holder. After the job is done, you can throw away the foam and wipe off the aluminum.

—Harry M. McCully, Allegany, N.Y.

Saw-sharpening stand

For those who prefer to sharpen their own handsaws, this sharpening stand is a winner. A wooden tightening bar,

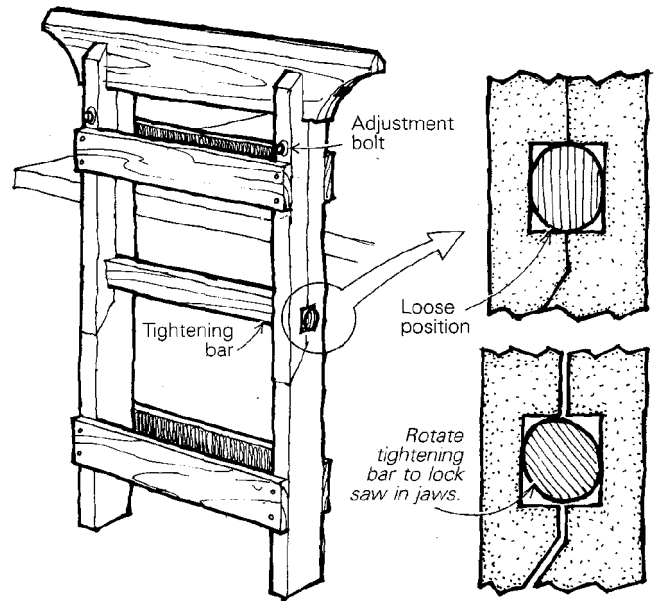

worked to an oval at both ends, wedges the stand's jaws shut on the sawblade when turned. The two adjustment bolts near the saw holders act as pivots. They should be tight enough to hold the saw in place before the tightening bar is turned. I'm 5 ft. 8 in. tall and the 44-in. height is comfortable for me.

When you sharpen, you normally have to maintain two different angles: tilting the file up in the air a little, and also angling it toward the tip of the saw. Here's a trick: Instead of

worrying about both angles, just tilt the saw stand so that it leans against the bench. Then you can concentrate on the angle toward the tip while you hold the file level.

—Brian Johnson, Sacramento, Calif.

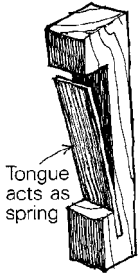

All-wood bench dogs

Here's a simple, inexpensive way to make bench dogs of wood, including the spring. First cut the dog to shape, as shown in the drawing at left. Then saw a kerf at the lower end of the dog and insert a wooden tongue of the same thickness as the sawcut. Simply press the tongue into place, don't glue it. When it breaks, it will be easy to replace.

—Michel Petrin, Ste-Marie Salome, Quebec

Enlarging flute bores revisited

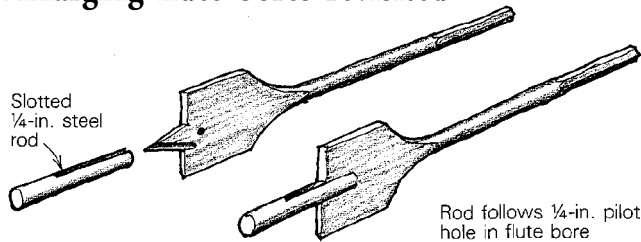

Here's my variation on the method Vasco Pini uses to enlarge the bores of flutes (*FWW* #35, p. 16). First drill a pilot hole through the flute blank with a 1/4-in. shell auger. Then construct a follower bit by cutting a slot in a short length of 1/4-in.

rod and slipping it over the tip of a spade bit. The rod will follow the pilot hole and the spade bit will self-center.

—Bob Vernon, Keuka Park, N.Y.

Plywood rack

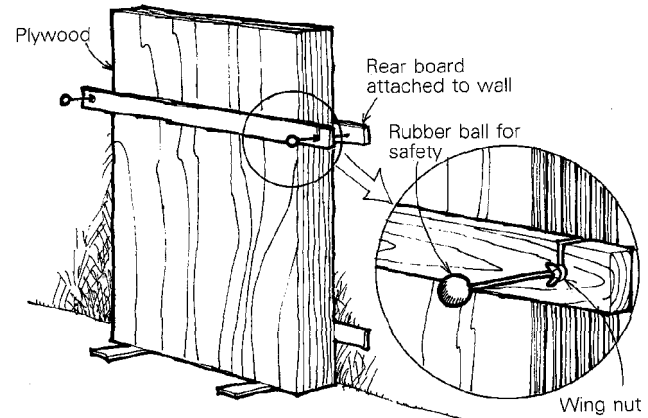

For those whose shop lacks the space to flat-stack sheets of plywood, here's a vertical rack that will neatly contain the sheets and prevent the warping that results from merely leaning the sheets up against a wall.

—Bruce Bozman, Addison, N.Y.

Methods of Work buys readers' tips, jigs and tricks. Send details, sketches (we'll redraw them) and photos to *Methods*, Fine Woodworking, Box 355, Newtown, Conn. 06470.

Cutting finger joints on the bandsaw

Here's how to cut finger joints on the bandsaw. In addition to being simpler and faster than the tablesaw approach, this method may be used with long boards (impossible on the tablesaw), and it allows you to lay out uneven spacing of tails and pins for decoration if desired.

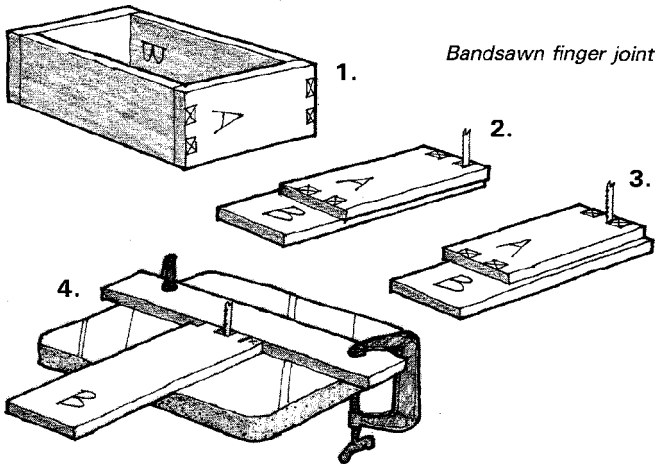

First lay out the spacing of the pins on the ends of the box members as shown in step 1, above. Strike an X through the areas to be sawn out. Now select one end and clamp it on top of its adjoining side member, offsetting the edge by one sawkerf as shown in 2.

Clamp a stop to the saw table behind the blade, extending the full width of the table. Position the stop so that the stock will be cut to the proper depth (just a shade deeper than the stock thickness). Make sure the stop is perpendicular to the blade's actual line of cut, which may drift to right or left.

To cut the joint, feed the clamped workpiece into the saw to the stop. On the first pass cut only the *left* side of the pins, splitting the line to the waste side. Now unclamp the two workpieces, shift the top workpiece (the box end) two sawkerfs to the left, reclamp and saw the right side of the pins (3).

Next unclamp the two boards and, working with one workpiece at a time, nibble out the waste between fingers by sawing kerfs as close together as possible. Dress the bottom of the notch by feeding the stock sideways across the face of the blade (4). Repeat the waste-nibbling process on the other workpiece. The two should fit together perfectly. If the joint proves too tight, don't shift the two boards quite as much for the second set of cuts.

—Walter D. Sweet, Hazardville, Conn.

Homemade bar clamps

You can never have too many bar clamps. But a woodworker's cash usually goes toward tools and machinery, leaving clamps for another day. The homemade model below, though made from light, cheap material, will do most (though not

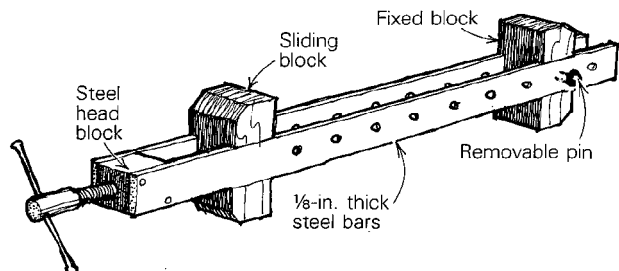

all) things a bar clamp will do. The two bars are made of mild steel, $\frac{3}{4}$ in. wide by $\frac{1}{8}$ in. thick. Clamp the two bars together and drill $\frac{1}{4}$ -in. holes spaced $1\frac{1}{2}$ in. apart. Make the head block from a $\frac{3}{4}$ -in. cube of steel tapped for a $\frac{3}{8}$ -in. threaded rod. With the head block carefully lined up and clamped in position, fasten it to the bars by welding, brazing or riveting.

Make the $2\frac{1}{4}$ -in. by 1-in. by 1-in. sliding block and the fixed block from any dense hardwood. Cut a $\frac{1}{8}$ -in. deep groove on each side of the blocks to give a sliding fit between the bars. Drill a shallow $\frac{3}{8}$ -in. hole in the sliding block to take the end of the threaded rod. So the rod won't continually bore its way into the wood, force a pellet of $\frac{3}{8}$ -in. steel into the bottom of the hole.

Braze a short length of pipe onto the end of the threaded rod and drill it to accept a tommy bar of $\frac{1}{4}$ -in. steel rod. Peen the ends of the tommy bar to keep it from falling out of the hole. In use, the work is slid between the bars to ensure even clamping pressure, and the fixed block is moved and pinned in the appropriate place for the width of the work.

This clamp will handle work up to $\frac{3}{4}$ in. thick and perhaps 24 in. wide. The clamp could be scaled up using heavier materials for thicker or wider applications.

An alternative use for the clamp is to prevent "spelching" (the splitting off of the end grain during hand planing). Move the clamp to the edge of the board so its blocks are flush with the end grain. The clamp may be used many times before its wood blocks need replacing.

—Robert Wearing, Shropshire, England

Archimedes' marking gauge

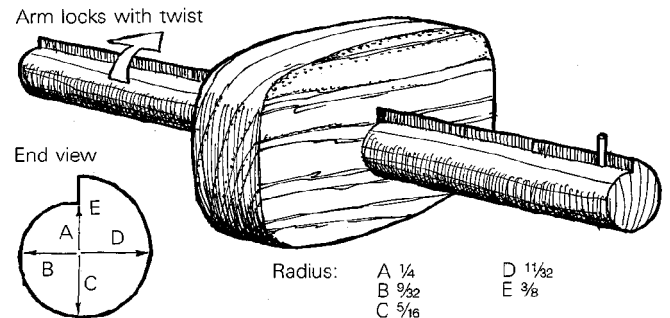

This marking gauge employs a simple bar-locking system consisting of one moving part. The shape of the bar is an adaptation of the Archimedes spiral—actually it is a scroll curve made up of tangential circular arcs. Make the bar and the fence from a close-grained hardwood such as beech. A slight twist of the bar will hold it securely, and a reverse twist will release it for adjustment.

—John Arthey, Southampton, Ont.

Portable exhaust fan

The various home-workshop exhaust systems I'd seen either were too expensive or would simply suck all the precious heated air from the shop. The latter problem is important when you live in a northern climate and like to spend long winter nights over a lathe.

The dust-exhaust system I built solves these problems. It is inexpensive, portable and of low velocity (so as not to empty all the heat from the shop). I mounted a 70-CFM bathroom fan to a 4-ft. long maple strip notched to hang on nails adjacent to my work areas.

The fan is vented through a standard dryer vent using

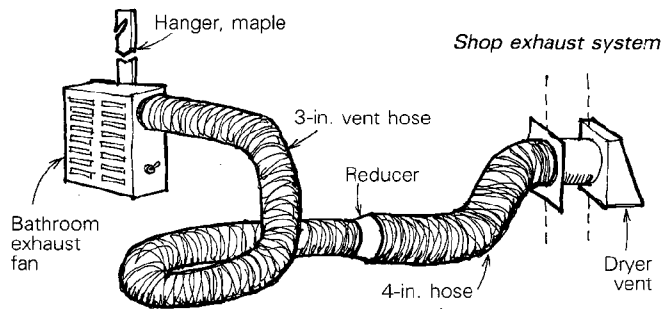

3-in. flexible bathroom vent hose. Since the vent hose is 3 in. in diameter and the dryer vent is 4 in. in diameter, I installed a PVC hose reducer to mate the two sizes.

For convenience and neatness, you can run the electrical wire through the hose or tape it to the outside. I installed a toggle switch to the fan box for turning the fan on and off.

The fan is handy for drawing paint fumes away, in addition to its main job of removing dust. But the darned idea works so well that even chips are drawn into the hose—I have to uncouple the hose and dump them out about once a month.
—Ronald R. Stoltz, Guelph, Ont.

Dressing thin stock

This jig allows you to dress stock to thinner than $\frac{1}{8}$ in. on a conventional thickness planer. Without it the thin workpiece will vibrate and often splinter on the ends.

To make the jig, glue 45° beveled hardwood cleats to a length of lumber as wide as and slightly longer than the wood to be dressed. The cleats can be any thickness, since they will

be planed down to the final thickness desired, at which time they serve as a rough thickness gauge for subsequent duplicate planing.

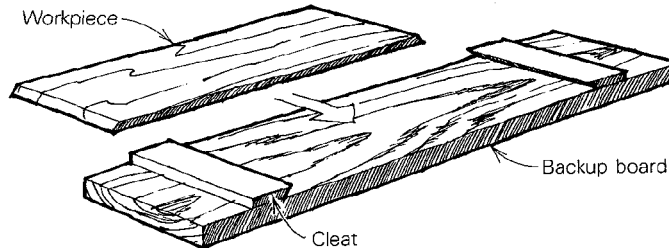

To use, bevel the ends of the workpiece so that it fits snugly under the cleats. Wax the back of the jig, slip the stock in the jig and run the jig through the planer, taking light cuts down to the desired thickness. Push the jig into the planer, then pull it through from the other side to prevent the feed rollers from pushing the workpiece out of its cleats.

—John S. Pratt, Avondale Estates, Ga.

Sanding canoe paddles

This setup speeds up the tedious job of rounding canoe paddle shafts. I suspect it has other applications as well.

To start, turn a wooden cylinder 18 in. long and 3 in. in diameter. Wrap it with masking tape, building it up in the middle to form a crown. This will help center the sanding belt as you work. Then turn a sanding belt inside out and place it over the wrapped cylinder.

I prepare the handle by squaring off a blank, then cham-

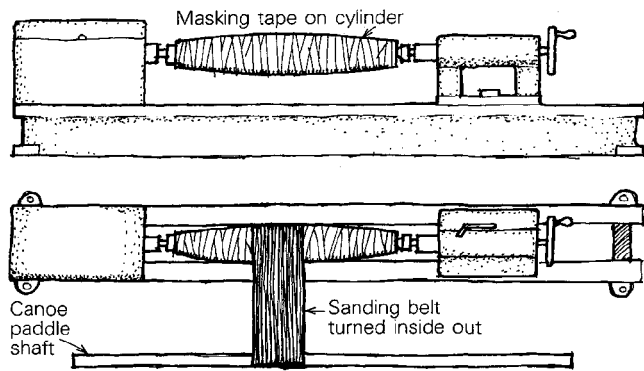

fering the corners, except where the blades will be glued on. I then stick the handle into the sanding-belt loop, pull tight and sand round. It will take a little practice at first, but eventually you will be able to make a difficult task simple.

—Wright E. Bowman, Jr., Honolulu, Hawaii

Collapsible finish containers

Collapsible plastic bottles for photographic chemicals (available from photo supply houses) make excellent working and storage containers for tung oil and other finishing materials that skin over or polymerize in half-empty cans. As the finish is used up, the bottles can be folded like an accordian before the top is screwed on, which eliminates just about all of the air.

—T. Carpenter, Calgary, Alta.

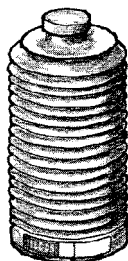

Scissor-jack fence

After years of enduring the inconvenience of removing and resetting numerous small bolts to adjust the fence on my router table, I made an adjustable fence that makes the whole process simple, rapid and accurate.

The fence is built around a used Toyota scissor jack that I found at an auto wrecking yard. First I spent a few minutes with a hacksaw to remove the portion of the jack that fits the underside of the car. Next I cut down the base to the width of the jack and bolted it to a 3/4-in. plywood backboard. To make the fence, I attached a piece of straight, well-seasoned cherry to the top of the jack. With the careful use of shims, I set the face of the fence exactly perpendicular to the tabletop.

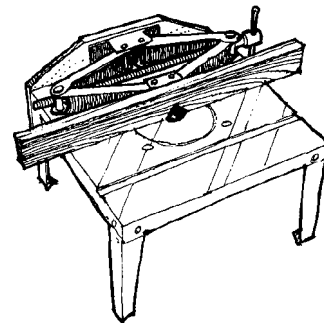

The fence is easy to adjust precisely. Once it's in position, I anchor it with small C-clamps on both ends.

I suspect that these readily available scissor jacks could easily be adapted to a wide array of clamping, pressing and fine-adjustment problems.

—John B. Moon, Mount Vernon, Wash.

Sanding drum

This homemade sanding drum is sized to fit belt-sander abrasive cloth belts. I use mine on a shaper, running it at less than 1000 RPM, but it would work on a lathe, too. To make it,

glue up a slightly oversize round blank as wide as the sanding belt you plan to use. To determine the required diameter, divide the belt length by π (3.14). Turn down the blank so

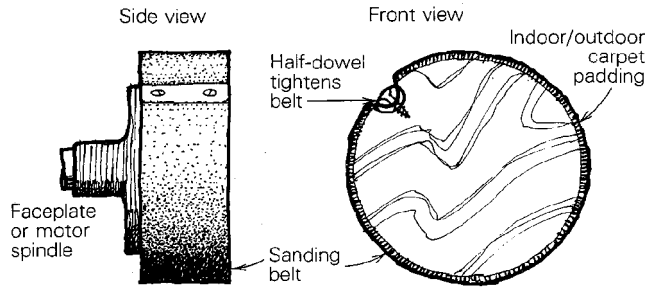

that the belt plus padding fits snugly. To tighten the sanding belt on the drum, rip a $\frac{3}{4}$ -in. dowel in half and install it in a slot in the circumference with flathead screws, as shown.

—Charlie Thorne, San Luis Obispo, Calif.

Hand-feed for the Parks planer

Here's a simple way to get an infinitely variable feed rate on a Parks Model 97 thickness planer, without altering any part of the machine. Simply install a hand crank on the throwout sleeve. Although no planer is 100% tear-proof, it sure makes a big difference once you get used to the feel of cranking wood through by hand.

To make the crank, I started with an old farm machinery crank and fitted it to a short keyed shaft that slides into the center hole of the throwout sleeve. To use it, I simply disen-

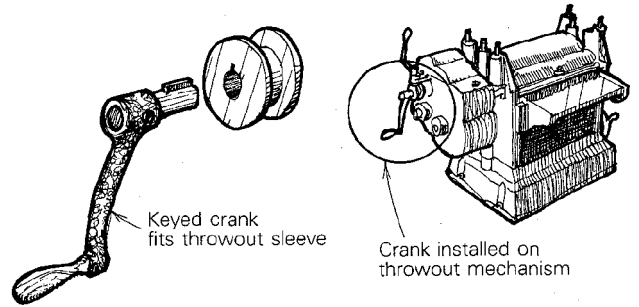

gage the power feed and start cranking. Make sure you remove the crank before you use the power feed.

This idea could probably be adapted to other planers that have a similar feed disengagement mechanism.

—John Colombini, Pittsburgh, Penn.

Picture frame clamp

These light-tension spring clamps are made by cutting up coils from an old bedspring. Sharpen the ends to needle points, then bend the circle so that the points are aligned,

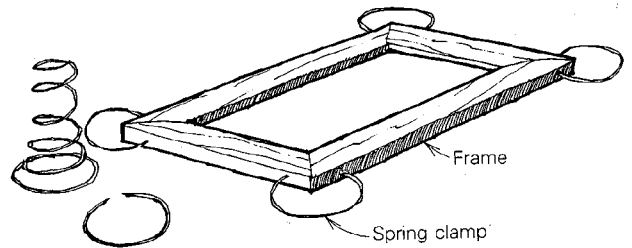

leaving a $\frac{3}{8}$ -in. gap. To use, simply place the frame to be glued on a flat work surface and use one of the spring clamps at each corner to clamp the frame. The points leave pinholes in the frame, but if care is taken, damage is minimal. For heavier or lighter clamps, just select and cut up an appropriate spring.

—H. Hugh Miller, LaHabra, Calif.

Spur dogs for clamping miters

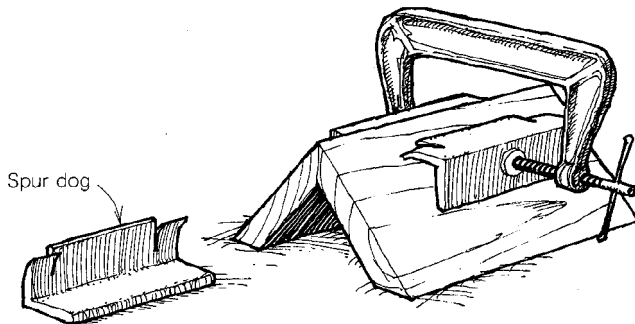

Here is a method that allows you to clamp up mitered edges. The method is based on a spur dog, a device that provides a perch for C-clamps and spreads clamping pressure evenly over the joint. To make the dogs, cut several pairs of 3-in. sections from a length of 1-in. angle iron. In each section, hacksaw two $\frac{5}{16}$ -in. deep slots about $\frac{1}{2}$ in. from each end of one side. Bend the two tabs down about $\frac{3}{32}$ in. and file the spurs sharp, as shown in the sketch.

To use, spread glue on both faces of the miter and press together for a light tack. Tap the two (or more) dogs into

place and clamp. The spurs enter the wood grain about $\frac{1}{8}$ in. and therefore leave small scars on the wood. These scars can be removed by rounding over the corner, or they can be dosed up some by steaming. You might decide to simply toleratethem.

—Peter Bird, Midhurst, Ont.

Chamfering tambour strips

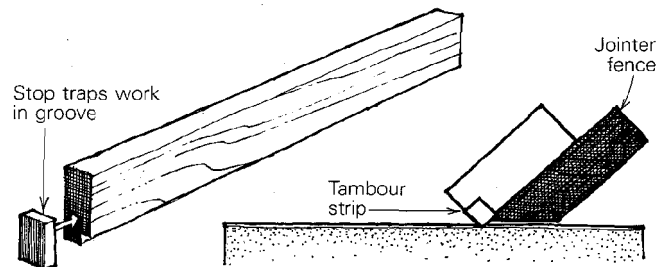

Here's a jig I developed to safely chamfer the edges of narrow strips, such as tambours. It consists of a straight piece of scrap as long as the strips and wide enough to be handled safely. Rabbet the bottom edge of the jig a fraction narrower and shallower than the strip, and attach a stop to one end of the rabbet. Now set your jointer fence to the desired angle, place a strip in the rabbet, and run the jig across the jointer. The depth of cut determines how wide the chamfer will be.

—Greg Forney, Gilcrest, Colo.

Methods of Work buys readers' tips, jigs and tricks. Send details, sketches (we'll redraw them) and photos to *Methods*, Fine Woodworking, Box 355, Newtown, Conn. 06470.

Fold-away ladder

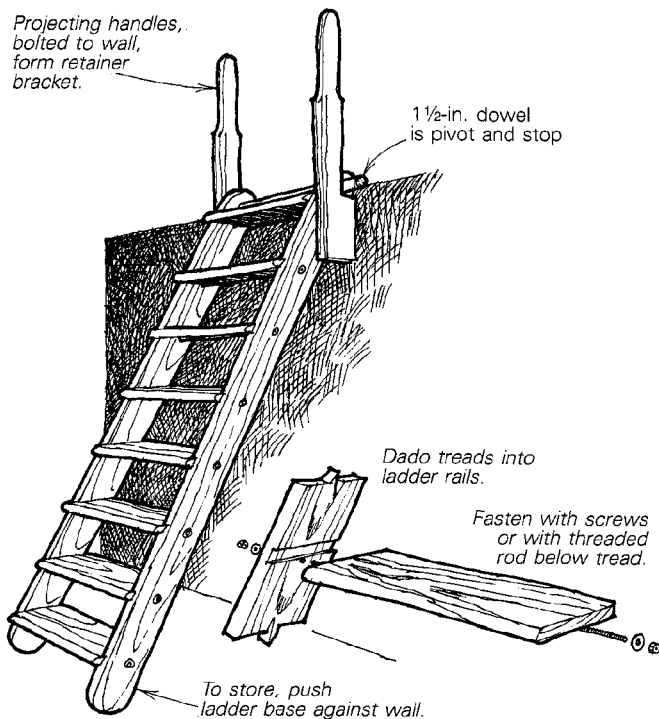

Needing some form of access to an overhead storage area, I rejected a stepladder (shaky and dangerous) and permanent stairs (loss of valuable shop space). The solution was a sturdy, shop-built, fold-away ladder. It is always there when it's needed and a simple pull locks it into place. Because the steps are wide (more like stair treads) and the slant is not so steep (20° from vertical), the ladder is safe and reassuring to use. The projecting handles at the top make the most unstable phase of descent—mounting the ladder at the top—hardly more precarious than descending your front porch steps. With few changes you could adapt the design for over-the-side access or through-the-ceiling access.

—William Lego, Springfield, Va.

Miter-gauge setting jig

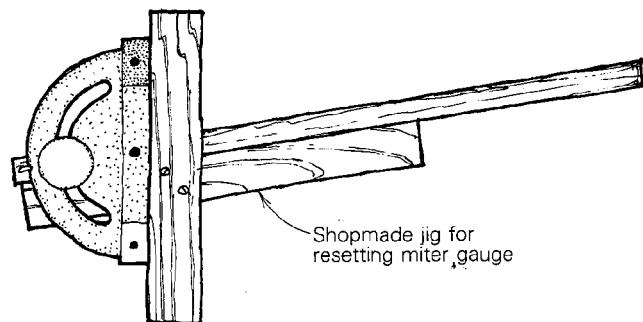

Some tablesaw miter-gauge settings are the result of tedious trial-and-error, cut-and-fit procedures. Here's how to preserve that hard-won setting for future use. Cut two 1x2 strips about 1 ft. long. Clamp one to the bar and one to the gauge face. Glue and clamp the strips where they overlap. Reinforce this joint with a couple of screws or dowel pins. When the glue has cured, you can reproduce the setting anytime you like simply by pushing the jig against the gauge.

—Tim Rodeghier, Highland, Ind.

Inlaying with dental silver

You can inlay silver into wood using the silver amalgam that dentists use to fill teeth. Draw the design on the wood, scribe the outline, then deepen the cut to $\frac{3}{32}$ in. or so with a small chisel or a rotary bur. Undercut the edge of the design to hold the amalgam (a dentist's inverted cone bur is ideal).

Now pack silver amalgam into the groove. After the alloy has set, smooth the surface with a flat tool. After 24 hours, level and polish the inlay with wet-or-dry sandpaper, finishing with 600-grit.

The inlay won't polish to a mirror finish, but will take on a softer sheen, something like pewter. It will need a coat of finish (tung oil works) to keep it from tarnishing.

For small designs (three initials about 2 in. tall, for example) the cost is minimal, probably about \$1.00.

—Lawrence Warner, Encino, Calif.

EDITOR'S NOTE: My own dentist's reaction was "Now why didn't I think of that." Intrigued, he showed me some premeasured plastic capsules (about the size of a cowboy's bullet), with powdered silver alloy in one end, mercury in the other, and a seal in between. A vibrating machine shakes the capsule end-to-end, and a little metal pellet inside the capsule breaks the seal and mixes the two ingredients, much like an agitator ball in a can of spray paint. He explained that different companies market different kinds of capsules with varying seal arrangements, amounts of silver, alloy mixtures and working consistencies, but none of the variables should affect the amalgam's use for inlay. The capsules he demonstrated contained silver the volume of a pea, and cost about 60¢ each.

He gave me a couple of capsules to try at home. There I found I could mix the amalgam by simply taping the capsule to the blade of a portable scroll saw and running it for 30 seconds at high speed. I also found that, in a pinch, you can mix the mercury and silver powder in a shot glass, using a rounded dowel as a pestle. Inlaying was no problem, but the silver will fill the pores of open-grained wood around the inlay, and it must be picked out later with a pin.

One cautionary note: free mercury is poisonous, as is mercury vapor. After mixing, the amalgam is non-toxic.

—J.R.

Shopmade tablesaw guard

During an evening's discussion with several other mechanics, I found that each of us came up with a good reason or two for not using the guards that came with our tablesaws. My long-tested shopmade guard, however, seemed just the sort of thing people would actually use. While it won't control kick-back, and won't protect against outright carelessness, it is a real help in my shop.

The guard is a piece of Lexan plastic suspended on a parallelogram arm fixture that keeps the guard parallel to the table at any height. The guard can be lifted for upright work and

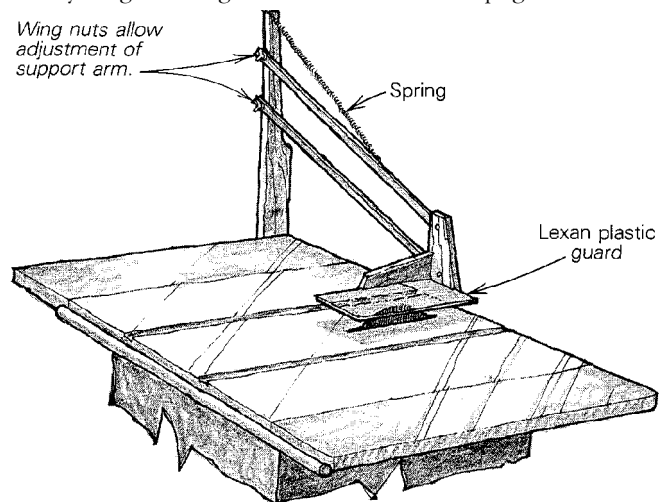

blade changes, then quickly lowered for ripping and cross-cutting. It keeps knots out of your face and sawdust from cascading behind your safety glasses. The plastic, if cleaned once a day, allows full view of the work without distortion, and its width keeps fingers well away from the blade.

The support post should be set back far enough to clear normal crosscut widths, and the entire post should be easily removable for cutting long work.

—Rod Goettelmann, Vincentown, N.J.

Decorative door joint

This homemade barrel-nut adaptation uses short sections of 1/2-in. ID iron pipe and captured 3/8-in. hex nuts. I installed several of these fasteners in an old weathered door to pull

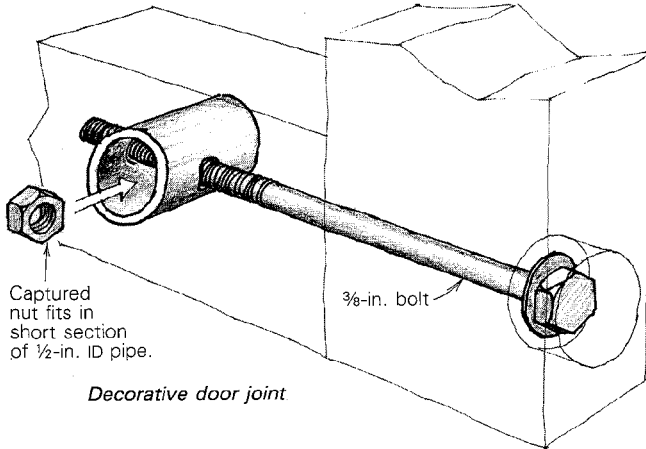

together the loosened glue joints. The joint would work in other applications as well, such as machine stands and workbench carriages. You can plug the holes in the pipe after the bolt is tight, allowing the metal to show like an inlaid ring.

—Jack Niday, Balboa Island, Calif.

Gripping thin wood

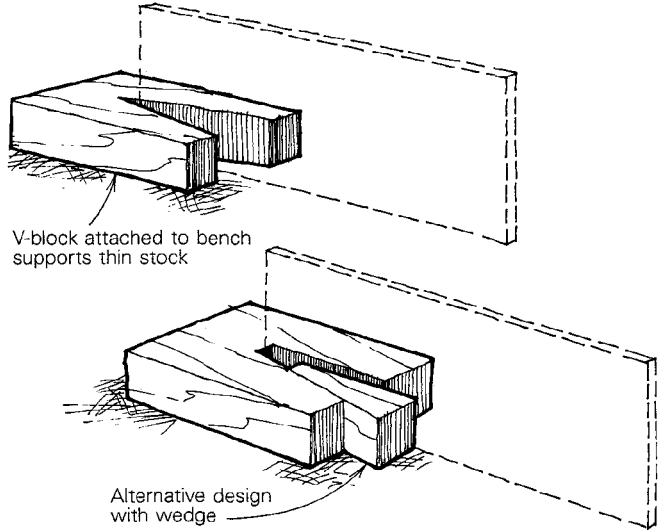

When I hand-plane thin wood on edge, it often gets away from me. This V-cut support block is like having an extra hand. I screw the block to the bench or fit it with dowels that

mate with holes in the benchtop. You should arrange the dowels near the mouth of the V and angle them back slightly so the block won't shift as you plane.

You might try a variation by cutting one side of the V parallel to the work and using a wedge for a positive grip. A pull on the workpiece releases the wedge.

—Percy W. Blandford, Stratford-Upon-Avon, England

Flush hanger plug

This wooden hanger plug, when fitted to a mirror or picture frame, allows the frame to be hung flush against the wall with the hanging screw concealed.

To make the hanger, cut a 1-in. diameter, 1/2-in. thick plug, counterbored with a 3/4-in. bit to a depth of 1/4 in. Cut a keyhole slot through the face of the plug (drill a 3/8-in. hole and a 3/16-in. hole and saw out the slot between the two). In the back of the frame, bore a blind hole 1 in. in diameter and

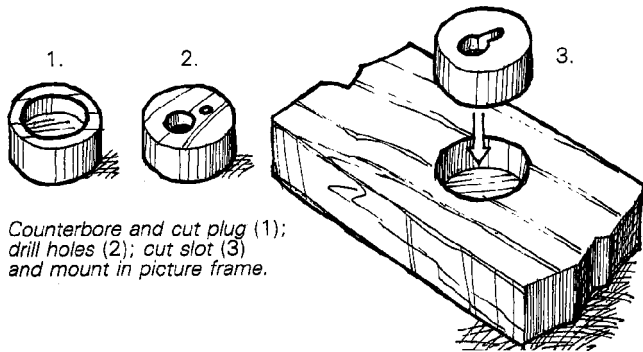

1/2 in. deep. Glue the plug in the hole with the narrow end of the keyhole slot up. The frame may then be hooked over a roundhead screw driven into the wall so that its head is just over 1/4 in. out. On heavy frames, you'd best use two.

—Edward Groh, Naperville, Ill.,
and Charles Cohn, Clarendon Hills, Ill.

Sliding dovetail fixture

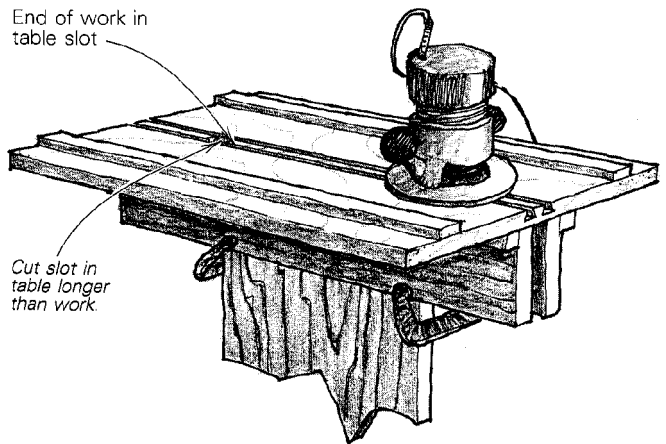

While attempting to rout long sliding dovetails on the end of shelving joints, I found it impossible to keep the over-wide and long shelves perpendicular to my router table. Here is a fixture I devised that, in effect, brings the table to the work. It's a platform with a slot in the middle and two perpendicu-

lars for sandwiching the work. To rout the dovetail, I clamp the work in the jig flush with the top of the platform. Two fences, attached at the proper spacing, guide the router and ensure a consistent dovetail. —Victor Gaines, Glenside, Pa.

Table design converts to desk

This table design folds in to convert to a more compact side-table or a desk. It has been quite convenient during my frequent Navy transfers, where my furniture has had to adapt to various household settings.

The two table sections are fastened together at the center by a piano hinge. The front section of the top is permanently attached to the apron along the front edge. The two side aprons are hinged to fold in, allowing the rear legs to move forward. At its folded-in position, the rear apron can be screwed to the tabletop for stability. The entire conversion takes just a few minutes. —Andrew J. Pitts, Orlando, Fla.

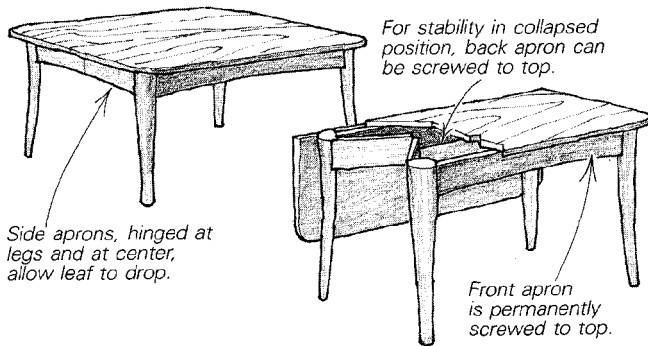

Safe ripping on the radial-arm saw

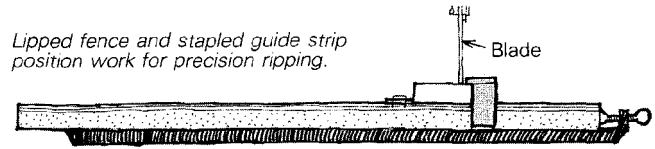

While building an architectural model requiring extremely small pieces, I discovered this safe, accurate way to rip short or small stock on my radial-arm saw.

The key is a substitute rip fence with a built-in hold-down lip made from 1/8-in. thick pine. I made several of the hold-down fences to cover a range of stock thicknesses. With the workpiece in position, clamp the fence in its channel so that the lip applies downward pressure. To keep the workpiece against the fence, I staple a scrap of pine to the table along the outboard side of the workpiece. These staples should be methodically pulled and tossed in the garbage when you change hold-ins, to eliminate the possibility of stray metal on the saw deck.

The method holds the wood securely so that it doesn't become a workshop missile, and provides extremely accurate pieces of short, thin stock.

—Ross Asselstine, Minneapolis, Minn.

Molding head or shaper hold-in

I wouldn't use this gadget for ripping, because it would tend to close the kerf, but it's a solution to the problem of holding the feedstock against the fence on a shaper, or when using a molding head on the tablesaw. Start with a 1 1/2-in. square

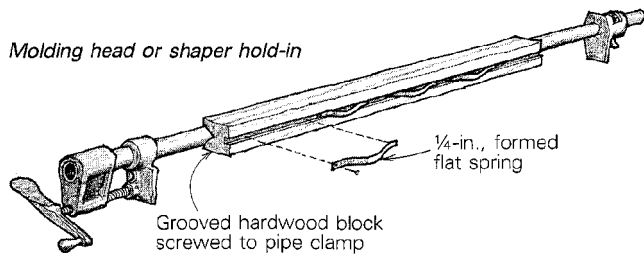

length of hardwood. Cut a V-groove in one side (to fit the pipe of a pipe clamp) and rip a 1/4-in. slot in the other side. Screw the hardwood to a pipe clamp long enough to fit your saw table or shaper table.

Now install several 1/4-in. flat steel springs in the groove. These springs, available at hardware stores, are used to repair old double-hung windows with broken weight ropes. Clamp the hold-in across the machine table in a position so that the springs flatten as the work is pushed through. To prevent the work from moving upward, it's a good idea to use this pipe-clamp hold-in in conjunction with a fingerboard that will press the work to the table.—*Raymond Yoke, Altoona, Pa.*

Splint joint

To splice pieces of ash splints for chair seats, first soak the splints to make them pliable. Then, with a leather punch,

1. Punch holes with leather punch.

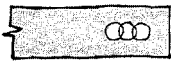

2. Trim.

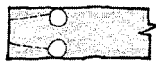

3. Lock together.

punch holes in the splints and trim the ends to the shape shown in the sketch. This procedure achieves the same result as the traditional method (knife and chisel), but it's faster, easier, and handier in tight places. And the rounded edges resist splitting while the seat dries and tightens.

—*Bruce Herron, Ganges, Mich.*

Graining tool

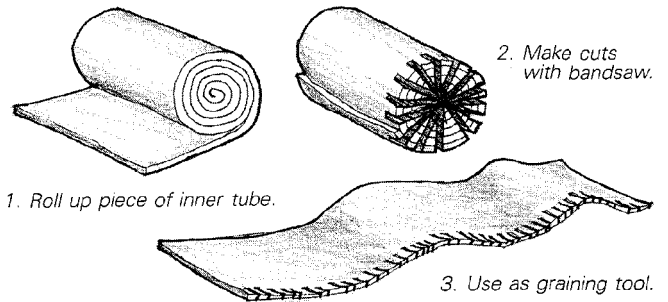

To make a graining tool that works on any contour, including intricate molding, roll up a strip of inner tube and notch its end randomly on the bandsaw with cuts about 1/8 in. deep. Then using a glaze of artists' oil colors, linseed oil and varnish, you can produce a striking grain pattern. . . with practice.

—*J.B. Small, Newville, Pa.*

Methods of Work buys readers' tips, jigs and tricks. Send details, sketches (we'll redraw them) and photos to Methods, Fine Woodworking, Box 355, Newtown, Conn. 06470.

Cutting flutes on curved turnings

For cutting reeds and flutes in curved and tapered turnings, I use a cutter mounted in a drill press, and a special indexing jig to hold the workpiece. Although making the cutter requires some time and moderate metalworking skills (or machine-shop expense), once it is done you can cut reeds and flutes on any shape with minimal set-up and excellent results.

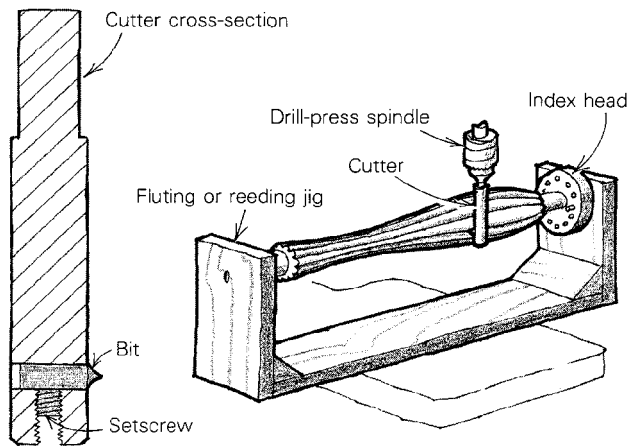

Make the cutter from a short length of $\frac{5}{8}$ -in. cold-rolled steel. Turn the top 1 in. of the cutter down to $\frac{1}{2}$ in. so it can be chucked in the drill press. Drill a $\frac{1}{4}$ -in. hole through the cutter $\frac{1}{2}$ in. from its bottom, and file the hole square to accept a short length of $\frac{1}{4}$ -in. tool steel for the bit. In the bottom of the cutter, drill and tap a hole for a setscrew, which holds the bit in place. Grind the bit to the shape of the profile desired for the reed or flute.

When the cutter is complete, you will also need a jig to hold the turning and to index the work as the flutes are cut. The jig can be either a simple one-time affair or of a more elaborate, permanent design incorporating an adjustable tail-stock. In either case, lay out the round indexing head carefully by dividing the circle into a number of equal angles according to the number of flutes required. For example, if 24 flutes are desired, then the pin holes on the index head will be 15° apart. On a permanent jig, you can use one indexing head for many combinations by laying out several concentric circles of pin holes, each with a different number of holes.

To cut the flutes, first turn and sand the workpiece, then fasten it in place between centers in the jig. With the jig in place on the drill-press table, lower the drill-press quill until the cutter bit is on the centerline of the turning. Lock the quill at this setting. With the drill press running at its highest speed, move the turning into the bit and across the table. The bit cuts the profile of the flute while the cutter body rubs along the turning, regulating the depth of cut. After the first cut, index the turning to the next hole and repeat the process until all flutes have been cut.

—Kenneth Weidinger, Erlanger, Ky.

Improved horizontal mortiser

This horizontal mortising router jig, shown above right, is a more versatile adaptation of G.R. Livingston's (*FWW* #22). The jig can be clamped in a vise, but is fully portable and could be clamped to a sawhorse, for example.

The fence is adjustable by means of two bolts and wing nuts, which lets you center the mortise in stock of different thickness. The fence can be locked in pre-set positions (for mortising $\frac{3}{4}$ -in. stock, for example) with a screw through the fence into the frame behind. My version of the jig is made

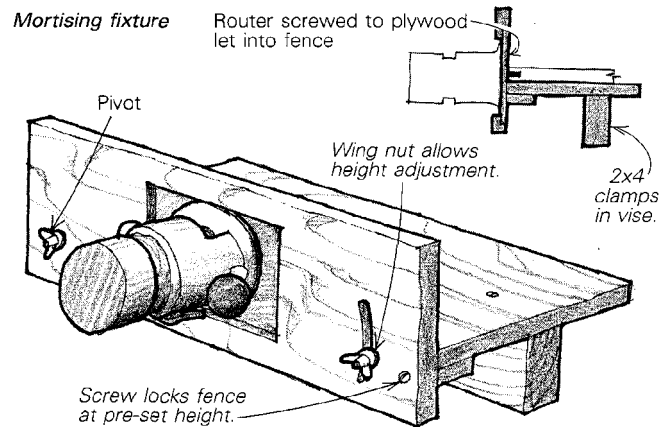

from plastic-laminate-covered particleboard sold for shelving. I mounted the router on a piece of $\frac{1}{4}$ -in. birch plywood recessed into the face of the fence.

—Charles W. Milburn, Weston, Ont.

Vacuum attachment for the router

Routing produces a lot of dust and chips. It is much more efficient to collect this messy waste as it is produced rather than to sweep it up later. The sketch below shows how I adapted my Sears router to hold my shop vacuum nozzle.

I positioned the nozzle so that it filled the gap near the router's work light. It's supported in place with a wooden

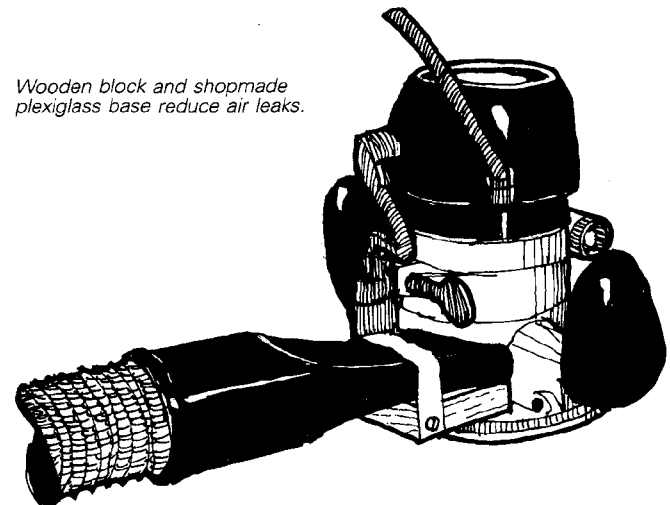

block (screwed to the base) and a steel band. To reduce air leakage through the holes in the router base, I added a solid base plate made from $\frac{1}{4}$ -in. clear plexiglass.

—Harry M. McCully, Allegany, N.Y.

Installing jointer knives

Here's how to replace reground knives in a jointer quickly and accurately. First crank the infeed table all the way down so it's out of the way. Place a knife and a gib in the cutterhead slot, with the screws tight enough to hold the knife in place but loose enough so that it can be moved. The knife should project about $\frac{1}{8}$ in. above the outfeed table.

Now place a piece of heavy plate glass on the outfeed table so that it projects over the cutterhead. Manually roll the cutterhead backwards until the projecting knife lifts the glass at the top of its turning circle. Hold the cutterhead in place and gently press the glass down on the outfeed table, pushing the

knife down into the cutterhead slot. If the knife was not exactly at the highest point of its arc, it will still be slightly too high. Rocking the cutterhead back and forth under the glass will level the knife with the outfeed table. Now tighten the gibs, then repeat the sequence with the other knives.

—Joe Robson, Trumansburg, N.Y.

Regrinding plane irons

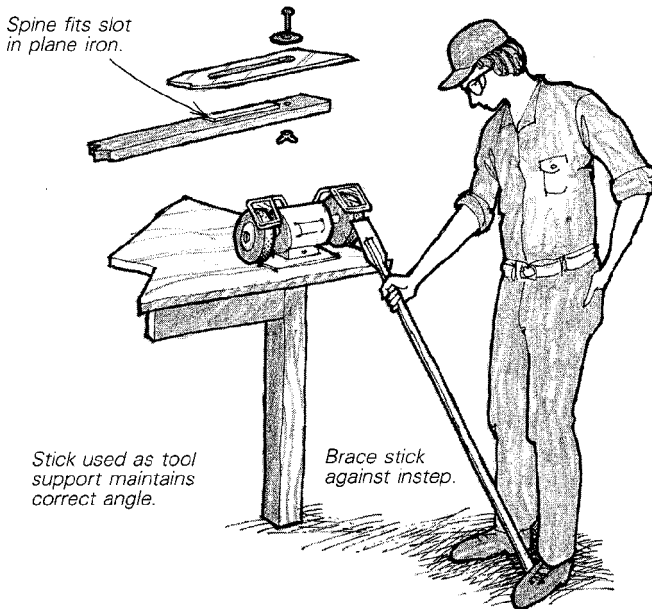

With a simple stick jig you can quickly, easily and accurately regrind plane irons on a bench grinder, and it's more fun than you can imagine. Select a good, stiff hardwood stick—mine is 44 in. long. Add a short wooden spine (to fit the iron's screw slot) and a stove-bolt/washer arrangement to hold the iron in place. Now, keeping the stick in line with the wheel, brace the stick against the inside of your left foot and lightly arc the iron across the wheel. The stick can be picked up to check the progress of the grind, then—as long as you don't move your foot—returned to the same spot against your shoe.

The resulting blade grind won't be perfectly straight but crowned ever so slightly. This convex profile will prove superior to a straight profile for most hand-planing applications, and is tricky to achieve any other way.

—Paul D. Frank, Fond du Lac, Wis.

Integral drawer pull

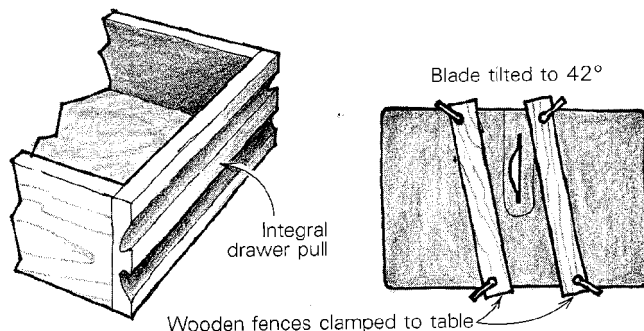

This flush, integral drawer pull can be made on the tablesaw. The profile seems to mirror gripping fingers, making it well suited to its task.

To make the grip, tilt the blade to 42° and undercut the

stock, running it 10° off line with the blade. Make several passes, raising the blade 1/8 in. or so each time, until you reach the final depth. As with all undercutting operations, the stock must remain flat on the table. To keep the board in place, I use two fences (straight pieces of wood clamped to the table-top on either side of the workpiece) and a hold-down.

—Ronald Neurath, Louisville, Ky.

Bicycle-tire sharpening wheel

During my seventy-two years, mainly through trial and error I've found certain methods that work well for me. One example is this sharpening setup made from a bicycle wheel.

Start with the complete front wheel and fork. I used a 26-in. by 2.125-in. tire. Mount the wheel assembly on a base so that its tire contacts the pulley (1 1/2-in.) of a 1/4-HP, 1725-RPM motor. Your wheel should revolve at about 100 RPM, with a surface speed of 650 ft. per minute. Now glue a strip of abrasive cloth to the tire surface, and you have a very efficient, low-cost grinding wheel. Use it so the sparks fly away from the tool. Because the speed is slow and the wheel is large, there is little heat buildup

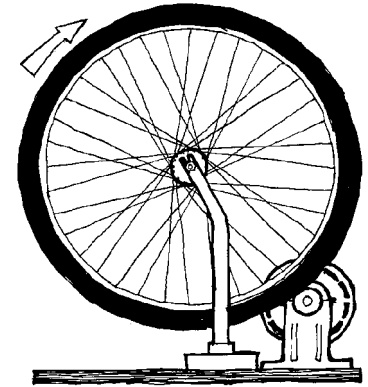

to burn a tool and ruin the temper. If you place the whole assembly on a bench, the work area will be at eye level.

As a companion tool I use a belt-driven mandrel fitted with five side-by-side, 6-in. muslin buffing wheels. I charge this thick buffing sandwich with 1000-grit abrasive, which gunsmiths use to polish gun barrels prior to bluing. I then polish all edge tools to a mirror-sheen, razor-sharp edge. The whole system is inexpensive and can be mastered by any flub-dub.

—Ray "Pappy" Holt, Tampa, Fla.

Router-table fence for edging discs

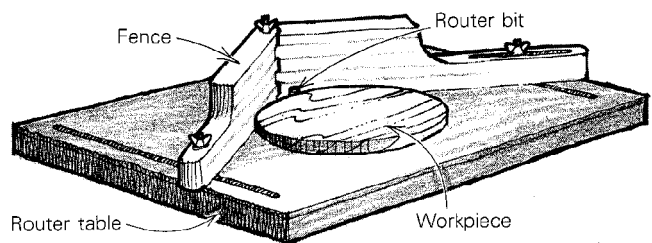

I developed the fence shown above to shape the edges of round rings, such as clock bezels, on the router table. The fence can shape both outside and inside edges of circular blanks. When shaping the outside edge, some part of the profile must remain uncut to provide a bearing surface against the fence, otherwise the disc would just keep spiraling smaller. The fence is made by laminating 2-in. wide, 1/2-in. thick plywood strips into two arms that fit together in a finger joint that pivots on a 1/4-in. bolt. The other ends of the fence arms fasten to the router table with wing nuts. Slots in both sides of the router-table top and in one arm of the fence allow adjustment for different size circles and different width rings.

The dimensions of the fence don't really matter, but I've found that the angle between arms cannot be less than 90° for safety and should not be more than 135°. At angles greater

than 135°, the workpiece rolls away from the router bit. These two extremes, therefore, dictate the spread between the two slots in the router table and the length of the adjustment slot in the fence arm. With the setup shown here, the work should be rotated counterclockwise, into the bit's rotation.

—Robert Warren, Camarilla, Calif.

Guide blocks for accurate hand-planing

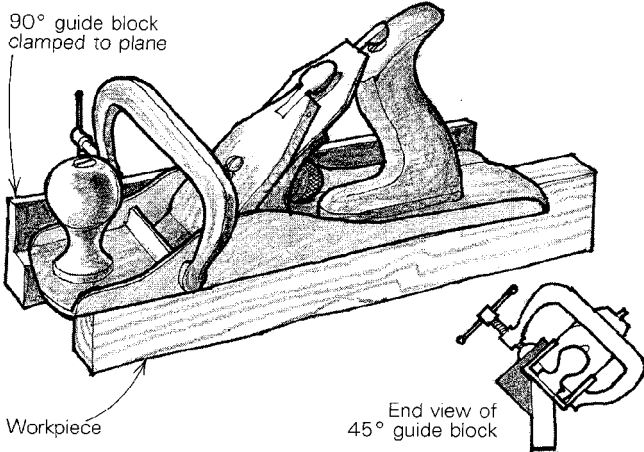

Because I don't own a jointer, I rely on my bench planes for truing up my lumber. To maintain a consistent angle, I cut guide blocks from scrap pieces of hardwood and clamp them to the plane.

I make a few passes, check the angle, then make final adjustments using the plane's lever arm to tilt the blade.

—Jack Gabon, Missoula, Mont.

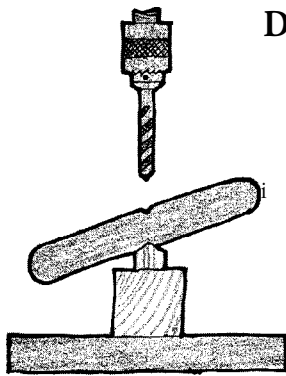

Drilling compound angles

Here's a simple method for drilling accurately through irregular workpieces, or for drilling tricky compound angles and having the hole exit where you want it. First clamp a board to the drill-press table and drill the hole to match a dowel on hand. Point a short length of dowel and insert it in the hole.

Now mark the workpiece for the entry and exit holes, and center-punch the marks. Make the exit punch fairly deep. Place the workpiece's exit punch on the dowel point and drill on the opposite punch mark.

—George Kasdorf, Ft. Wayne, Ind.

Three-jaw "overshoes" for bowlturning

Like many avid woodturners, I use a three-jaw chuck for bowlturning and other faceplate work. With it you can avoid screw holes in the bottom of the bowl or skip the step of gluing on a waste bottom with paper between. But the three-jaw chuck is limited in the size range it can hold, and it contacts the workpiece at only three points, limiting the strength of its grip—if you overtighten it you will mar the work. I overcome these problems by adding wooden "overshoes" to the chuck. The overshoes, shown above right, are simply three 2-in. thick, wooden circle segments. I cut a groove in the back of each segment and bolt the piece to the jaw with two countersunk Alien bolts. Annealed chuck jaws, which can be drilled and tapped for the bolts, are available

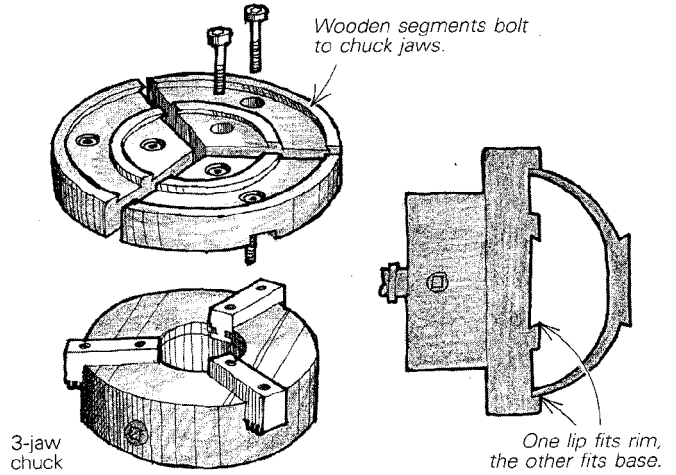

for most chucks; it's handy to have more than one set.

In the face of the wooden overshoes I turn two recesses, slightly dovetailed, to fit the rim and the base of a bowl. I mark both the overshoe segments and their matching jaws—if removed, each overshoe must go back on the same steel jaw it came off.

To use the overshoe chuck, I first mount the bowl blank on a large screw center and turn the outside to rough dimensions, taking care to size the base within a range that will fit the overshoe chuck. Then I reverse the blank, remount with the overshoe chuck gripping the base, and turn the inside of the bowl. When the inside is complete, I reverse the bowl in the chuck, gripping it by the rim to complete the outside. This technique is particularly useful when working green wood, which must be turned rough, dried, then remounted for turning to final shape and finishing.

—A.R. Hundt, Blackmans Bay, Tasmania

Sawing and assembly work station

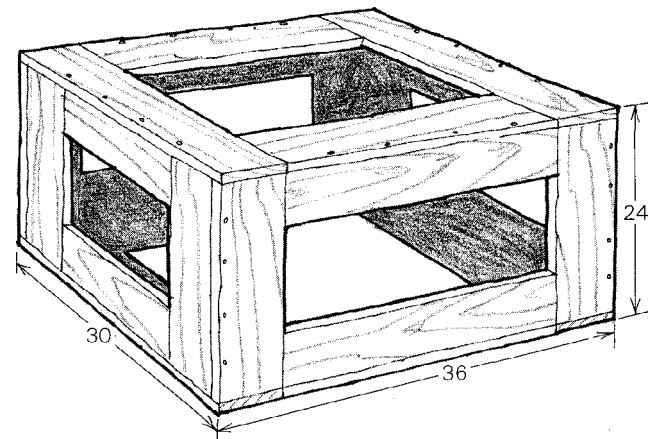

Here's a shop aid that let me put three different sets of sawhorses out to pasture. It makes a strong, portable work station for sawing, sanding, assembly and other operations. Simply flop the box to position the work 24 in., 30 in. or 36 in. off the floor, whichever is convenient. Construct the unit by screwing together six dowel-joined frames.

—Bill Nolan, Munising, Mich.

Methods of Work buys readers' tips, jigs and tricks. Send details, sketches (we'll redraw them) and photos to Methods, Fine Woodworking, Box 355, Newtown, Conn. 06470.

Low-tech horizontal boring machine

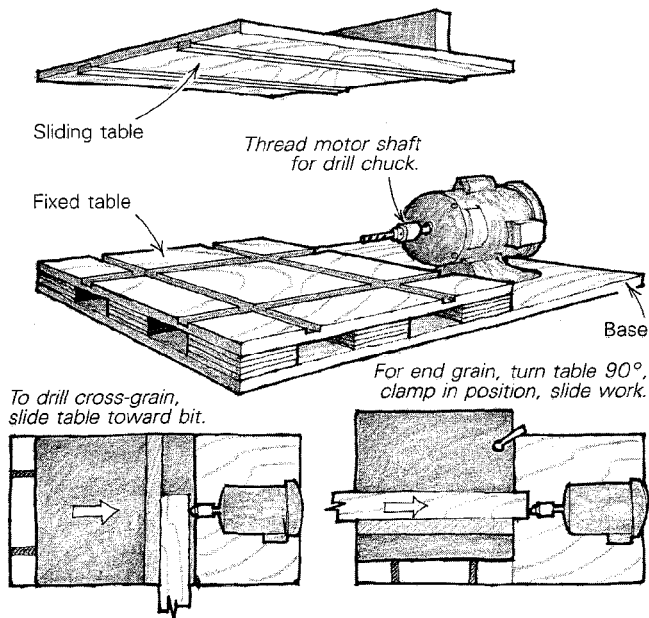

My home-built horizontal boring machine isn't as sophisticated as M.G. Rekoff's (*FWW* #37), but it's simple in design and sturdy enough to do an outstanding job. Its simplicity comes from a sliding table that moves the stock into the bit rather than vice versa.

To begin, you'll need a $\frac{1}{4}$ -HP to $\frac{1}{2}$ -HP, 1750-RPM motor, with its shaft threaded to accept a $\frac{1}{2}$ -in. drill chuck. I made the base, the fixed table and the sliding table out of $\frac{3}{4}$ -in. Baltic birch plywood.

Cut two square pieces the same size for the fixed table and the sliding table, then make all dado cuts at the same rip-fence setting to ensure that the dados align. Glue and screw hardwood runners into the dadoses in the sliding table. These runners should then fit either pair of tracks in the fixed table.

Next bolt down the motor assembly and the fixed table to the base. Shim the fixed table so that the sliding table will be at the proper height relative to the bit. Glue and screw a fence to the top of the sliding table.

The height of the sliding table is not adjustable in this design. This presents no hardship for me because most of my boring is in $\frac{1}{4}$ and $\frac{5}{4}$ stock. I shimmed the fixed height so that my machine would normally bore $\frac{5}{4}$ stock. To switch over to $\frac{1}{4}$ stock, I place a sheet of $\frac{1}{10}$ -in. plexiglass on top of the sliding table. —*Ed Devlin, Rothsay, Minn.*

Drawing an ellipse

Here's how to draw all or part of an ellipse with a lath and a framing square. First, lay out the major and minor diameters of the ellipse on the workpiece, and clamp a framing square on these lines with its outside corner at the center. Install a pencil in a hole near one end of the lath, and measuring from the pencil, drive two brads through the lath, one at distance A from the pencil, the other at distance B. Clip off the brads

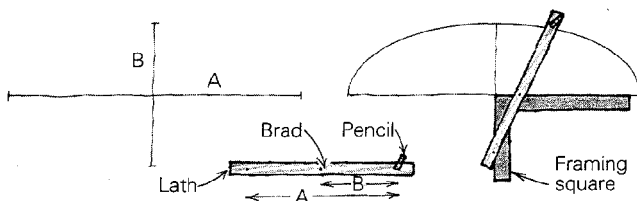

so that they don't protrude more than the thickness of the square. If you swing the lath, keeping one brad riding the top edge of the square and the other brad riding the side edge, you will scribe one-quarter of the ellipse. Flip the square, re-clamp, and repeat the procedure to complete the ellipse.

—*Frank Grant, Round Pond, Maine, and Matt Longenbaugh, Darrington, Wash.*

Segmented hinge column

This segmented joint works like a hinge for pivoting panels or doors, but also is a structural member capable of supporting loads like any other column. The hinge is composed of three basic elements: a pin, bushings and wooden joint segments. For the pin I use an ordinary threaded rod. The bushings are washers cut from brass shim stock. Wooden joint segments are made from a large dowel. The design of the joint segments may vary depending on strength requirements, panel thickness and aesthetic preferences.

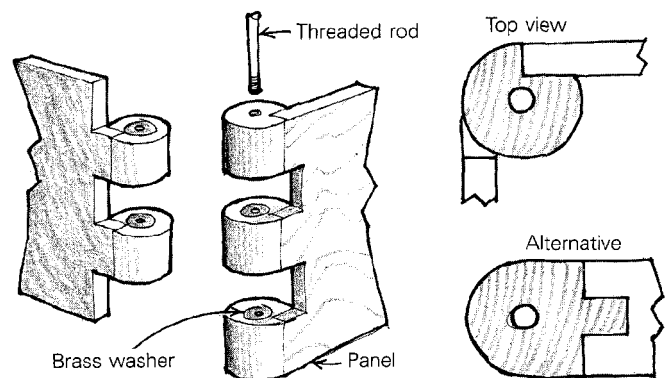

To make the hinge, first notch the dowel by passing it over a router mounted in a table. To keep the dowel from turning, tack a thin board to it. Cut the shaped dowel into segment lengths, keeping in mind that their length shouldn't exceed that of your drill bit. Next, drill the bushing hole in each segment. Proper alignment is important, so clamp a locating block to the drill-press table so that the bushing hole will be straight and centered. Assemble the segments on the threaded rod with brass bushings between, then glue the segments in place, one panel at a time.

—*Peter Kaphammel, Jr., Abbotsford, B.C.*

Reversing lathe rotation for sanding

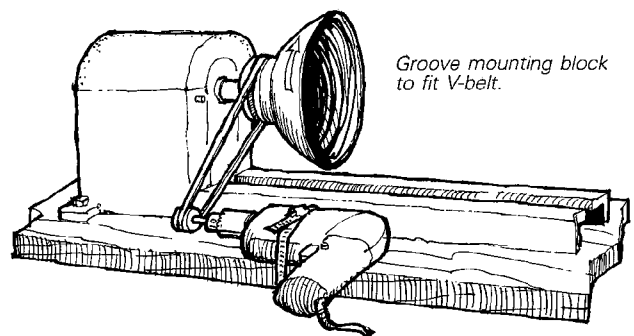

Here's how I reverse the rotation on my lathe for sanding turned bowls. This approach reduces the problem of the face-plate unscrewing from the spindle, as often happens if you reverse the motor or the drive belt. After the bowl is turned, I cut a pulley groove in the glue block. Then I chuck a ply-

wood pulley mounted on a 1/4-in. bolt into my electric drill. I mount the drill to the lathe bed and use a small V-belt to turn the bowl in reverse rotation.

Be sure to remove the lathe's drive belt before starting up the drill. Otherwise, the drill motor would be fighting the inertia of the heavier lathe motor. This method will work on stock held between centers, too. Just leave enough waste stock at one end for a pulley groove.

—Lawrence A. Fortier, Pleasant Ridge, Mich.

Handsaw storage rack

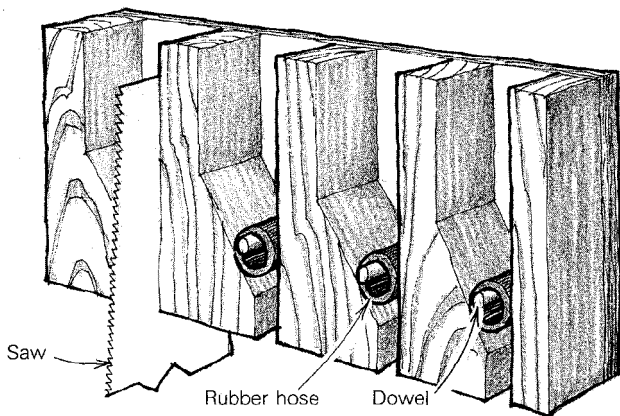

This shop-built saw holder provides a convenient place to store handsaws and straightedges that may be leaning against a wall or lying about in your workshop. To use it, slip the saw in from the bottom and give it a tug down to wedge it in place. I used 1/2-in. plywood for the back of the rack and 2-in. material for the partitions. I found that rubber hose from an automobile heater works better for the grippers than plastic garden hose, which is too smooth. The dimensions aren't critical, but if the dowels are too high, the hose won't pinch the sawblade. If they are too low, the hose jumps to the floor when you remove a saw. Trial and error will find the happy medium.

—Kim Anderson, Loyalton, Calif.

Drill-press safety switch

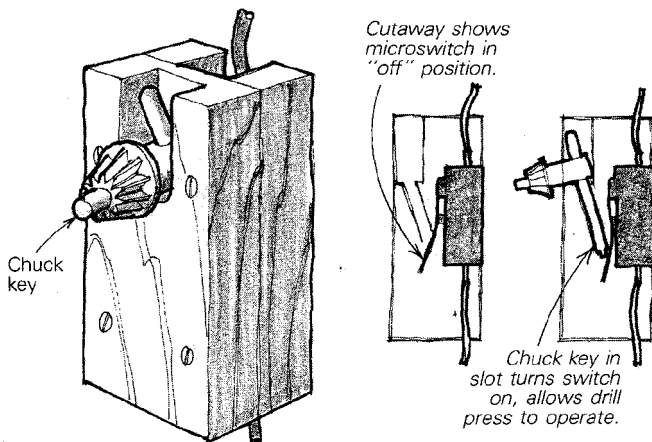

If, like me, you've ever been barely missed by a flying drill-press key you inadvertently left in the chuck, you'll appreciate this inexpensive safety device. It consists of a lever-operated microswitch encased in a box fastened to the front of the drill press. The weight of the key dropped in a slit in the box moves the hinged lever on the switch and closes the circuit.

The drill press should be wired through the device so that the existing on/off switch will operate normally only if the key is in the slot. Since several types of switches are available, make sure the one you use is a heavy-duty, motor-rated switch that will carry the amps your motor draws.

—Wesley Glewwe, West St. Paul, Minn.

Accessible saw switch

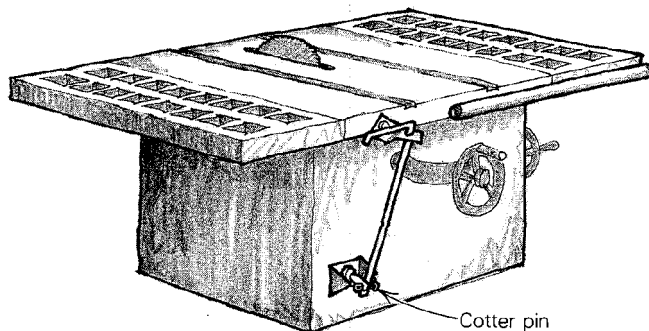

I recently bought a nearly new tablesaw, and soon decided that I could not get used to the location of the motor starting switch, which seemed too far away for comfort and safety. To correct the problem, I attached an extension rod to the switch so that I could shut the saw off instantly without contortions. The rod is supported by an aluminum plate that I twisted in a vise to the correct angle and attached to the saw table in an existing bolt hole.

—Alfred Gorski, Stratford, Conn.

Plane-iron honing tool

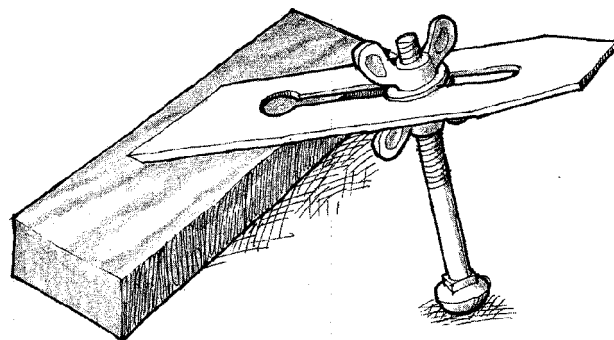

Here's a simple, inexpensive jig for honing slotted plane irons. Just attach a 4-in. long, 3/8-in. or 1/4-in. carriage bolt to the iron, as shown in the sketch above. The round head of the bolt slides easily on the bench, maintaining a constant honing angle. For fine adjustment or for honing microbevels, you can shim the stone, or twist the bolt up or down a hair.

—Paul Weissman, Centerville, Ohio

Improved hot-glue faceplate technique

To avoid screw holes and to speed assembly, I attach turning blanks using hot-melt glue chips and a torch-heated faceplate. Aluminum faceplates work better for this method because they conduct heat well and cool quickly. If your faceplate is iron, you can attach a thick aluminum face to the faceplate with flat screws.

First, be sure the bottom of the blank is flat. Then heat the faceplate with a torch and place it on the turning blank to warm the wood. Cut thin discs of hot-melt glue (no gun needed) and place them on the heated blank in amounts proportional to the bulk of the blank. Use enough to secure your

doubts as well as your wood. Place the faceplate on the blank, and clamp in position until cool.

After turning is complete, aim a torch at the faceplate, heating it enough so the wood falls off with a gentle tap. While the glue is still hot, clean up the faceplate with a rag and scrape the glue from the bottom of the turning.

—Randy Kalish, Belen, N.Mex.

EDITOR'S NOTE: Several readers have expressed concern for the safety of previous faceplate attachment methods using hot glue or double-sided tape. Kalish's method seems more secure than these. Nonetheless, each reader should test this, or any other new technique, to be sure it is safe in his own application.

Variable-width dado fixture

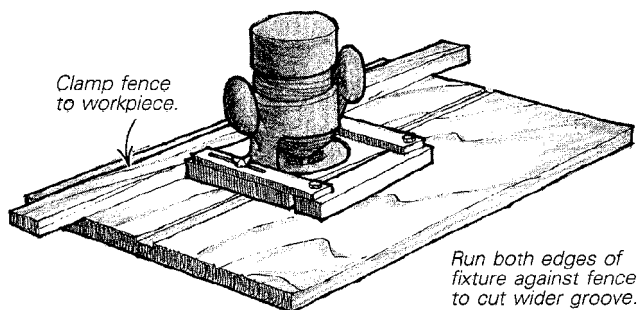

This variable dado fixture will allow fine adjustment of the dado width from bit diameter to double the bit diameter. The fixture works on the principle that one edge of the router base is farther from the bit than the other. To use, clamp a fence in place on the workpiece and make one pass with the wide side of the fixture against the fence. Turn the router around (narrow side to the fence) and make a second pass.

To make the fixture, cut a 9-in. square from 3/4-in. hardwood plywood and rout a 1/2-in. deep recess in the center to receive the router base. Rip one edge off the fixture and reattach it with two cleats, as shown. Slot one cleat to allow adjustment. The other cleat is fixed, and the adjustable edge is pinned to it so that the edge can pivot. You will have to trim the corner of the base outside the pivot point so that the adjustable edge won't bind. After the fixture is attached to the router, check to be sure that the distance from the bit to the adjustable edge is slightly (1/16 in.) less than the distance to the fixed edge. If it isn't, saw a little off. Otherwise, slight adjustments over bit size are impossible.

—Jere Cary, Edmonds, Wash.

Lathe template fixture

A few months ago, while teaching lathe duplication methods to my cabinetmaking class, I discovered a novel and efficient method of rapidly producing identical turnings. Mount a template of 16-ga. metal on a swinging arm at the back of the lathe. After the stock has been turned round, swing the

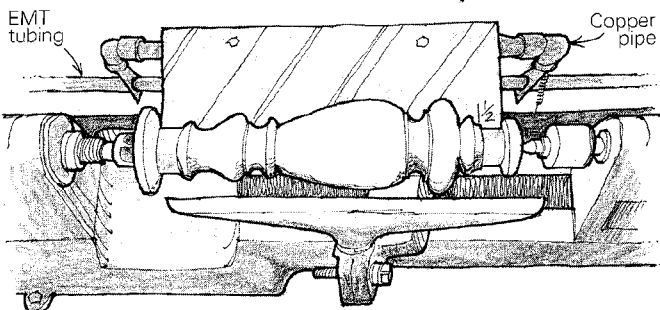

template against it with a light spring, maintaining enough tension to prevent excessive bounce. By cutting from the front in normal fashion and referring visually to the template at the rear, you will be able to quickly and accurately produce any number of identical turnings with few rejects and a minimum of tedious measuring and calipering.

To keep each turning the same diameter, scratch a final diameter reference on a short, straight run at each end of the template. Work each end of the turning to these reference diameters first, then the gap between the reference diameters and the template will show the maximum cut depth to be taken from the workpiece's high spot.

My version of the duplicator is made from 3/4-in. copper pipe, copper pipe elbows and a length of 1/2-in. EMT conduit. Solder up a U-shaped assembly from the copper pipe, flatten the pipe on each of the U's legs and drill to pivot on the conduit. Flatten the crosspiece of the U and drill to attach the template. Adjust the angle at which the template hits the work by heating the joints of the U and turning the template to the proper position. —Doug Christie, Fort Grant, Ariz.

Pin-router adaptation for radial-arm saw

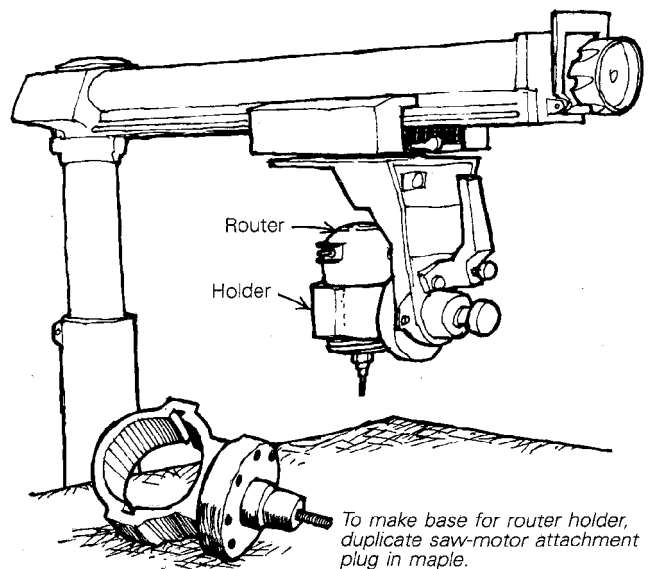

You can easily convert a radial-arm saw to a pin router. This tool will open up a whole new world of operations, and make many familiar tasks—such as rabbeting for book shelves or cutting mortises and slots—much easier.

To convert my Sears 10-in. saw, I merely duplicated on the lathe, in rock maple, the saw-motor attachment plug where it fits the motor support arm. I laminated the ring assembly that holds the router from plywood. Then I glued and bolted together the laminated rings and the maple plug to form a single unit. Details of this fixture would vary to suit the saw/router combination. For specifics about setting up the pin and using templates, see *FWW* #29, pp. 63-65. Also, if the setup is combined with a machinists' dual-feed rotary table, to hold and move the work, very precise work is possible.

The router is normally used in the vertical position, but it can be rotated to any orientation (just like the saw) for special routing cuts.

—Donald Wigfield, Moneta, Va.

Methods of Work buys readers' tips, jigs and tricks. Send details, sketches (we'll redraw them) and photos to *Methods*, Fine Woodworking, Box 355, Newtown, Conn. 06470.

Recycling sawblades into knives

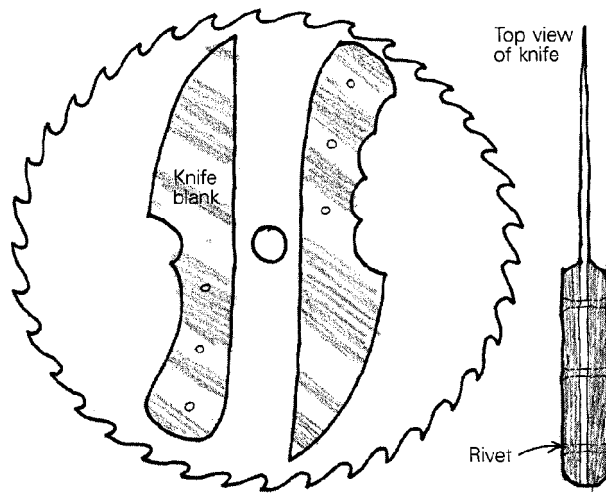

If one of your old circular-saw blades has seen better days, you may want to use it to try your hand at knife-making. Most sawblades are made of excellent high-carbon steel and are about the right thickness for a beefy camping knife or a custom-fitted woodcarving tool.

First, cut the blade into manageable pieces with an abrasive cut-off wheel. Then anneal the knife blanks using charcoal in a barbecue—play a hair dryer on the coals if you need more heat. Heat the blanks until they glow red (as seen in dim light), then allow them to cool very slowly in the fire as the charcoal burns itself out. Grind the annealed blank to shape and drill holes through the tang for the rivets that will attach the handle's "scales." Taper the blade's thickness from heel to point, and bevel the cutting edge with a belt sander, a file, or even sandpaper wrapped around a stick.

Now you're ready to harden the blade with the barbecue forge. Heat it cherry red, then plunge it into a pail of water. Next, polish the blade with sandpaper, and reheat it in a 550° kitchen oven for about twenty minutes, until the surface turns bronze, verging on purple. When the color is right, you can quench the blade in water or just let it air-cool. (For more about color and tempering, see *FWW* #4, pp. 50-52.)

Finally, attach the hardwood scales to the tang with epoxy glue and rivets. You can make your own rivets with heavy brazing rod or copper ground wire. This is not only a good use for old sawblades, but also a good use for those small pieces of fine hardwood that you just couldn't throw away: they make beautiful handles. —Jim Stuart, Covina, Calif.

Block sander from sanding belt

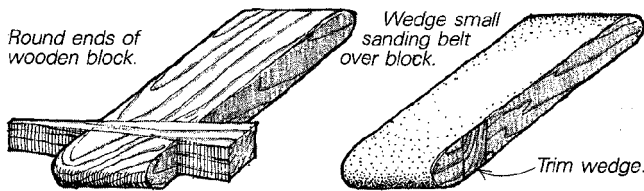

With the wedge-tightened block shown here, you can use small sanding belts as block sanders. The tight belt makes for better sanding action, and because cloth sanding belts are of a better quality than abrasive paper, the blocks last a long time. You can shape the end profiles for inside sanding, too.

—Robert J. Harrigan, Cincinnati, Ohio

Center finders—three variations on a theme

An old organ-builder friend showed me this handy home-made guide for center-drilling holes in the edges of boards to be doweled and edge-glued. The device consists of five sticks of hardwood screwed together in the configuration shown.

The sticks should pivot so that the device collapses like a parallelogram. For the drill guide, fit the center strip with a bolt $\frac{1}{8}$ in. larger than the bit size. Then, using a drill press for

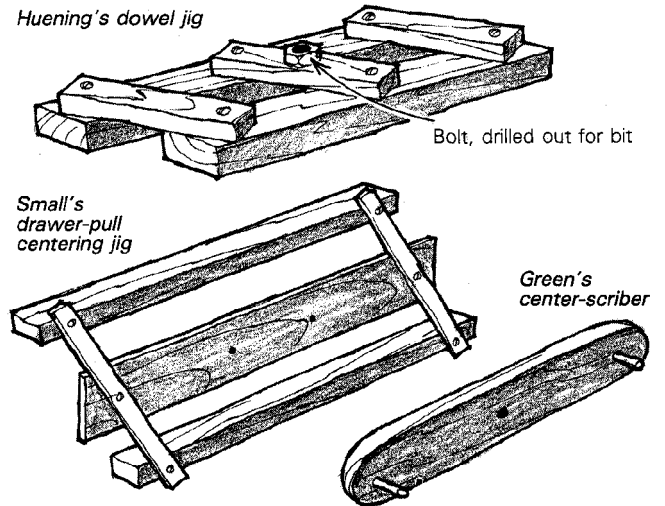

accuracy, drill a pilot hole through the bolt using a bit one number larger than the bit you intend to use for doweling. To use, first align the edges of the boards and mark off the dowel locations with a square. To center the dowels, set the device to straddle each board's edge and squeeze the parallelogram shut. Then slide the device to each mark, and drill.

—John Huening, Seffner, Fla.

Here's a self-centering jig for boring drawer-pull holes. The pivoting sticks should be made long enough to span your widest drawer. The center plate may be fitted with drill-bit guide bushings or just small holes for marking with an awl.

—J.B. Small, Newville, Pa.

This old-time gadget is handy for center-scribing boards. Install dowel pegs at the ends of the device and drill a hole in the center for a pencil point.

—Larry Green, Bethel, Conn.

Flip-up router fence

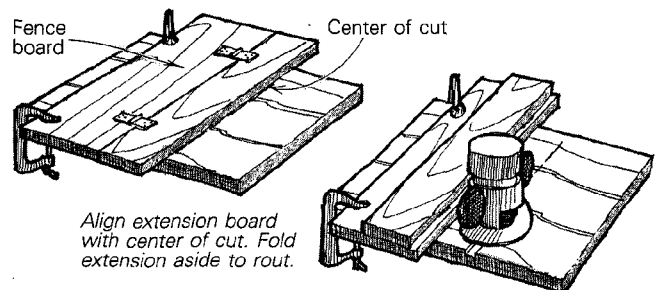

When routing grooves, some people draw a line on the work where the groove will be, then calculate where to damp the fence. Others draw the line where the fence will be, instead of marking the location of the groove. Both methods have obvious drawbacks. But if you make a router fence that has a hinged extension, you can mark the center of the actual groove on the work, line up the extension with the mark, then flip it out of the way to rout the groove. Make the fence

out of a straight, flat 1x4. Now rip another board half the diameter of your router base (measure from the center of the bit to the edge of the base) and secure it to the fence with flat hinges. As shown in the drawing, offset the hinges so that they won't protrude when the extension board is swung up out of the way. —James F. Dupler, Jamestown, N. Y.

Mortising table for drill press

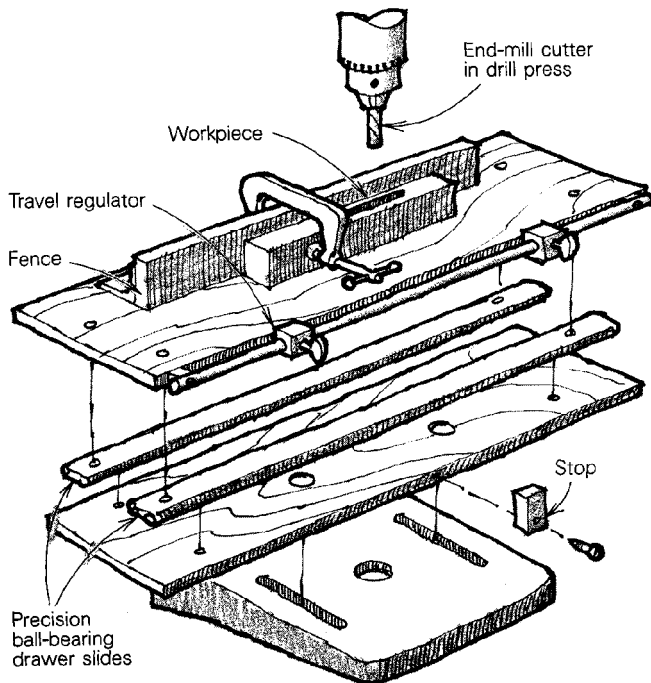

Frustrated with hollow-chisel and router mortises, I made this drill-press mortising fixture, which works even better than I expected. Its secret is a pair of precision ball-bearing drawer slides. Precision drawer slides have less play than regular drawer slides, and move so smoothly that I'm sure there are other uses for them in the shop.

This is how the fixture works. First chuck an end-mill cutter in the drill press, then set the travel regulators to produce a mortise of the desired length. Now position the fence to center the mortise in the thickness of the stock. To cut the mortise to the desired depth, gradually lower the cutter while sliding the table back and forth.

Rather than squaring up the ends of the mortise, I simply round over the tenon with a file.

—David Grimm, Richmond, Mich.

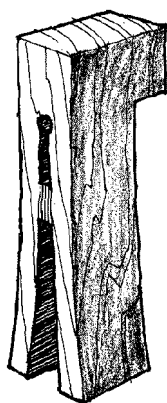

Improved wooden dog

A couple of years ago, we furnished our Tage Frid style workbenches with these maple dogs. They are strong, easy to make and adjustable to any height.

Cut the dog to rough shape, sizing it for a loose fit. Then drill a hole through the dog so that it won't split when you wedge it open. Next cut the dog's body with a bandsaw to the drilled hole. Wedge layers of thin veneer in the kerf until the two halves are flared enough to hold the dog securely.

—Michael L. Sandiland and Phil Holland, Vancouver, B.C.

Tool-grinding fixture for the belt sander

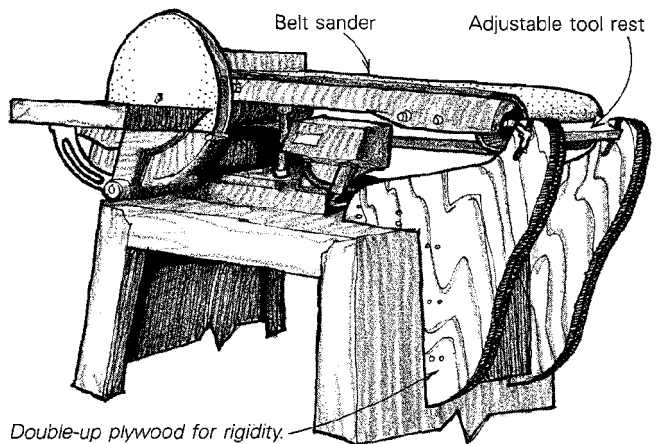

We developed the fixture above to take advantage of our belt sander as a wide-surface grinder. Because the sanding belt has much more surface area than an abrasive wheel, the grind is cool, with less danger of overheating the cutting edge. The fixture is easily removed, so it doesn't interfere with other, more conventional uses of the belt sander. The tool rest can be reset using a wing-nut/slot arrangement to grind at different bevels, or to give more or less hollow grind.

—Steve Vetter and Norman Gritsch, Washington, D.C.

Routing multiple mortise-and-tenon joints

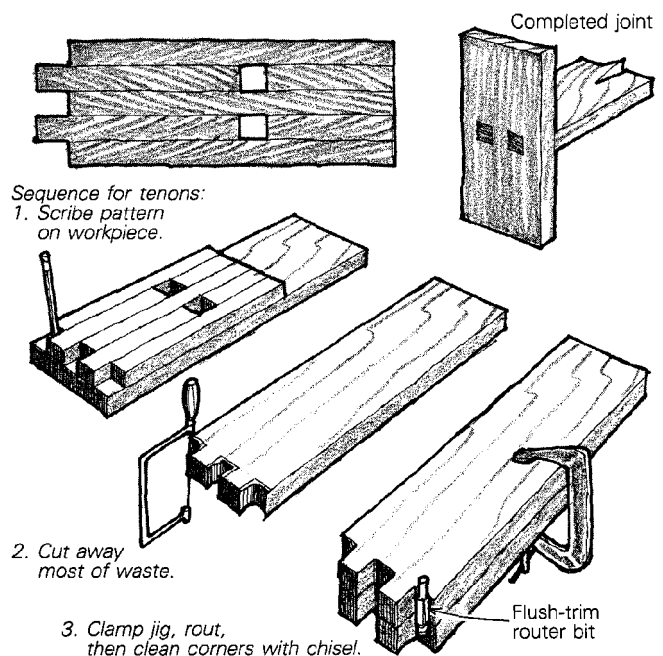

After several less-than-satisfactory attempts to construct through, wedged multiple tenons, I designed this router jig for accurate, repeatable results.

The jig consists of strips of plywood or particleboard laminated together as shown in the drawing. The long, continuous pieces correspond to the spacing between mortises. The shorter pieces are glued up to form openings and projections that correspond to the thickness of the stock.

To use the jig, place it over the workpiece to be mortised (or tenoned) and pencil in the outline of the joint. Remove

most of the waste. Now damp the jig in place under the workplace so it becomes a guide for the bearing of a flush-trim router bit. This results in dean, accurate mortises or tenons with straight sides except in the corners, which must be cleaned up with a chisel. If the jig is accurately lined up with the edge of the workpiece, the spacing of the mortises and tenons will be identical. —Ed Devlin, Rothsay, Minn.

Shaping with pencil-sharpener cutter

In my woodworking classes, I have been using an old spiral cutter from a pencil sharpener, chucked in the drill press, for smoothing small-radius internal curves. The cutter works very well, and saves the time and tedium of sanding or filing.

To make the tool, simply hacksaw one of the two cutters free of the mechanism. Replace the pin with a short length of $\frac{3}{16}$ -in. cold-rolled steel rod. Make sure the drive gear is on the bottom, for the correct cutting action. Hammer the bar a bit so that it will wedge tight in the spiral cutter. To use, chuck the cutter and lock the quill.

—David Glen Whitling, Bolivar, Ohio



Producing dollhouse siding

Here's how to produce simulated clapboard siding for dollhouses with a router and an easy-to-make subbase. First, to make the subbase, bevel a $\frac{3}{4}$ -in. thick, 6x10 block on the tablesaw in much the same fashion as you would cut a raised panel. Be sure to leave a $\frac{1}{16}$ -in. or so fillet, as shown. Now bore a hole through the block, and mount the router so that a $\frac{3}{4}$ -in. straight bit chucked in it is tangent to the fillet of the

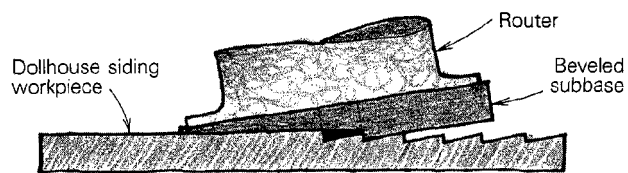

base. After experimenting with the bit depth, you should be able to rout multiple beveled cuts across the workpiece, indexing each cut in the previous cut. For narrower siding, relocate the subbase on the router and use either the same or a smaller bit. —Jim and Dan Partner, Newport, Ind.

Preserving green bowl blanks

To eliminate checking on green bowl blanks, simply store them in your freezer until you're ready to turn. I even use the freezer for storing work in progress if I'm interrupted before completing the rough-turning. This method is especially useful if you have a large number of green blanks and don't have time to rough them out so that they will dry properly. For long-term storage, wrap the blanks in plastic bags to avoid freezer burn and surface drying.

Another advantage of the method is that the frozen blanks turn without building up heat at the cutting edge—your gouge will need sharpening less frequently. Also, spalted wood, soaked and frozen, holds together much better.

—Joel N. Kutz, Brockport, N.Y.

Methods of Work buys readers' tips, jigs and tricks. Send details, sketches (we'll redraw them) and photos to Methods, Fine Woodworking, Box 355, Newtown, Conn. 06470.

Center-drilling dowels

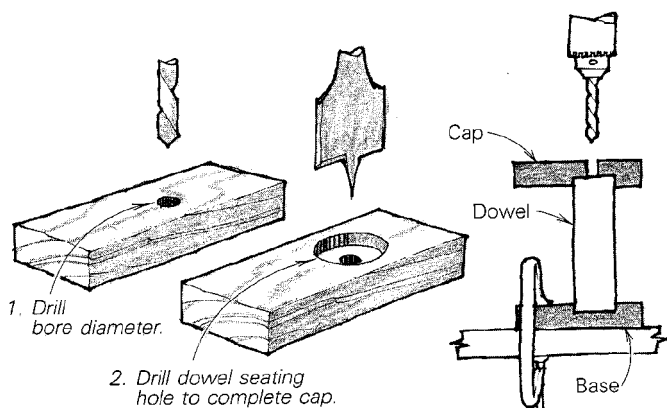

Here's a procedure for accurately center-drilling dowels. Clamp a piece of scrap to the drill-press table and drill a through hole the diameter of the hole to be bored. Without moving the block, change to a dowel-sized bit and drill a shallow seating hole. This completes the cap.

To make a base, clamp another piece of scrap to the drill-press table and drill a seating hole in it. Place the dowel in the base hole, and cap the top end so that the boring bit is centered. For long dowels, drill first from one side, flip, and complete from the other side.

—Robert J. Harrigan, Cincinnati, Ohio

Lathe steady rest

This shopmade steady rest can be set up to support the middle of a long, thin spindle, or it can be used as a tailstock for center-boring. Derived from a metalworkers' steady, the rest consists of a rigid plywood upright, three adjustable hardwood bearing blocks, and a base that locks in place on the lathe bed. The bearing blocks adjust by means of $\frac{3}{16}$ -in. eyebolts threaded through tapped right-angle braces screwed to the upright. Each bearing block slides between two guide blocks, and locks in place with a wing nut. Apply beeswax to the bearing blocks for ease of adjustment and to reduce friction on the workpiece. Of course, the base arrangement depends on your particular lathe.

—Robert L. Koch, Tarkio, Mo.

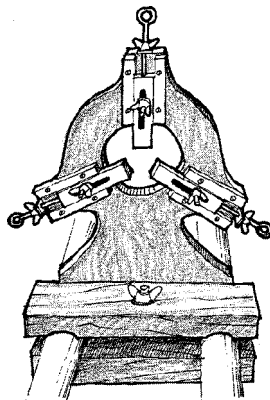

Regrinding plane irons

To grind an accurate bevel on a plane iron, remove the cap iron and replace it on the beveled side of the iron at 90° to its usual position, as shown in the sketch. The cap iron will work as a stop against the tool rest, maintaining a perfect bevel angle while allowing you to slide the plane iron to and fro. Vary the bevel angle by positioning the chip breaker closer to or farther from the cutting edge.

—Drew Woodmansee, Fairbanks, Alaska

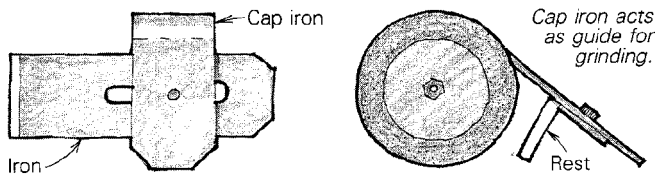

Routing wooden spheres

Last Christmas, I wanted to give my wife a sphere covered with $\frac{1}{2}$ -in.-sq. mirrors. Styrofoam was my first thought, but a plastic ball would have cost \$32, so I decided to make one from wood, and devised this simple router fixture to do it.

First, glue up a rough sphere by laminating graduated discs of plywood or solid wood; the larger discs should be rings, to save weight and material. Drill a hole through the north and south poles so that the blank can be mounted on a threaded-rod axle inside a box frame, as shown in the sketch. Washers serve as shims to center the blank in the frame.

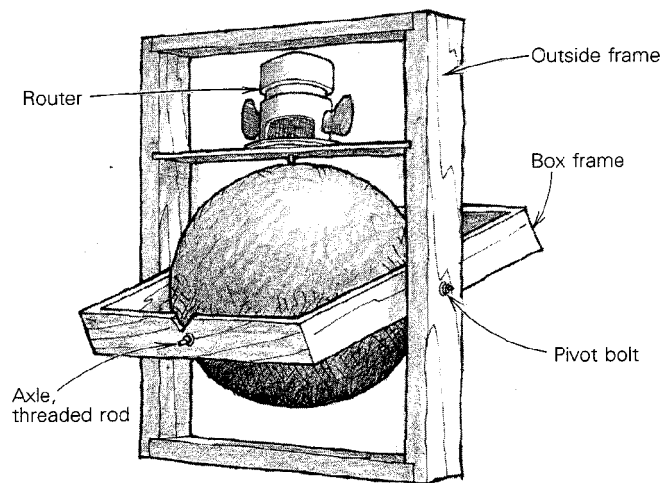

The outside frame is just wider than the box frame, which pivots inside it on two mounting bolts. The sphere should rotate smoothly within the box frame; the box frame should turn smoothly within the outside frame.

Center a router on a platform so that the bit is suspended over the sphere.

To rout the sphere, first clamp the fixture to the bench. Then rotate the rough sphere to find its high spot, and set the router bit a little lower than this. Turn on the router and rotate the sphere inside the box frame, occasionally pivoting the box frame a little within the outside frame. Continue lowering the router bit until the sphere is true. Except for a small area at each pole, the router bit can reach every point on the sphere. The small flat spots at the poles can easily be rounded off by hand.

—Frank D. Hart, Plainfield, Ind.

Printers' brayer spreads glue

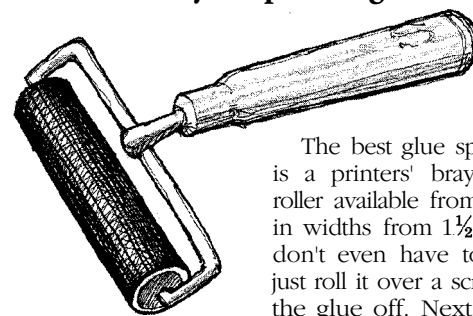

The best glue spreader I've found is a printers' brayer, a soft-rubber roller available from art supply stores in widths from $1\frac{1}{2}$ in. to 6 in. You don't even have to wash it clean—just roll it over a scrap to get most of the glue off. Next time you use it, any residue will disappear.

—Floyd Foess, Federal Way, Wash.

Machining octagonal turning stock

Spindle-turning goes faster and smoother if you begin with octagonal stock rather than square, but often it seems more trouble to machine an octagon than to simply whack the cor-

ners off on the lathe. Here's a tip that lets you easily machine octagonal stock on the jointer. Multiply the width of the square stock by 0.2071. The result is the amount, measured diagonally, that must be removed from each corner to produce eight equal sides. To make the cuts, set the jointer fence to 45°. For a safe depth of cut, you can divide larger measurements into a number of equal parts and make several passes.

—Robert M. Vaughan, Roanoke, Va.

Squaring bandsaw cuts

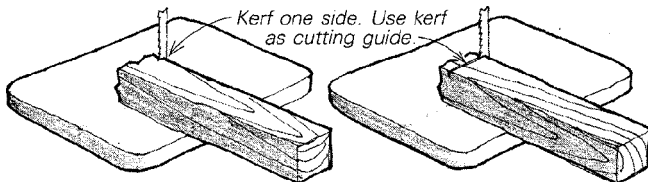

Here's a bandsaw trick that lets you true the end of a turning square without pausing to use a try-square. All you have to do is begin a crosscut on one side of the blank, then turn that side up and use the mark as your cutting line. As long as your bandsaw blade is at 90° to the table, you can't miss.

—Jim Ryerson, Guelph, Ont.

Cabinet latch

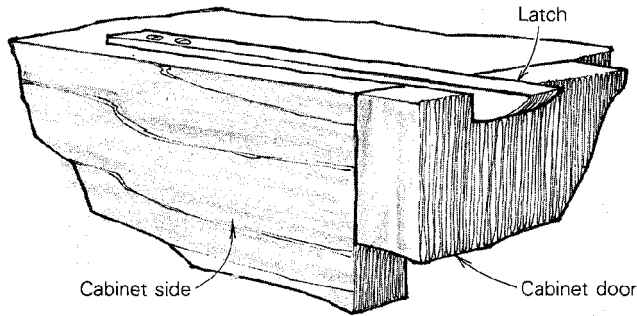

To make this handy latch for tool-cabinet doors, bandsaw the shape shown from a 6-in. long, 3/4-in. thick piece of springy hardwood, such as ash. Screw the latch to either the top or the side of the cabinet. —James F. Dupler, Jamestown, N. Y.

Trig jig for accurate angles

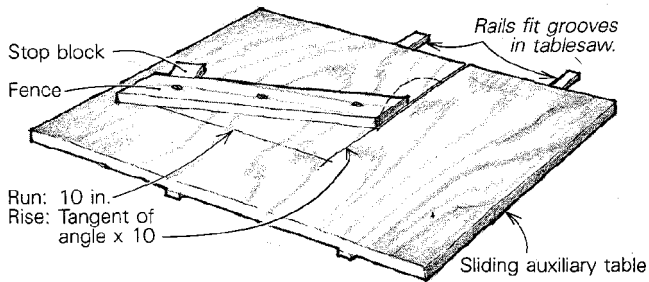

With this simple jig and a little trigonometry, you can cut odd angles on the table saw more accurately than with the saw's miter gauge. First, construct a sliding table using two maple rails and a piece of 3/4-in. plywood. To ensure perfect alignment, lay the rails in the saw's grooves and tack the plywood to them temporarily, then flop the plywood over and screw the rails down. Next, raise the sawblade and cut about halfway across the jig.

Trigonometry provides an easy and accurate method for

laying out the angled fence. Find the tangent of the desired angle from a trigonometry table or with a pocket scientific calculator. The tangent gives you the ratio of the angle's vertical rise to its horizontal run. If your angle is 11.25°, for example, the tangent is 0.19891 (rounded to 0.2). Therefore, for each inch of horizontal run, the vertical rise is 0.2 in. To make layout easier, scale up the measurements by multiplying by 10. This results in a base horizontal line of 10 in. and a vertical rise of 2 in. Mark these measurements on the jig as shown in the sketch and draw a line between the two points to locate the fence. —Eric Scbramm, Los Gates, Calif.

Routing spline slots in mitered frames

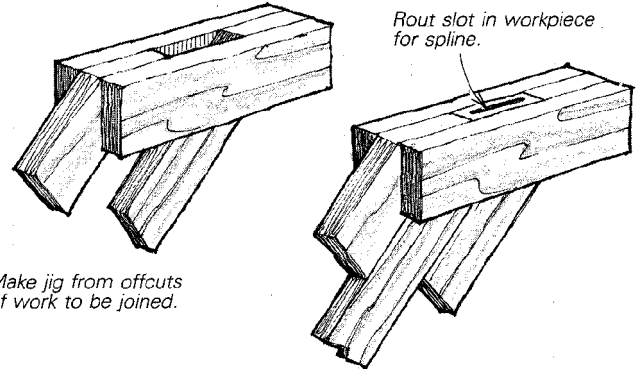

Make jig from offcuts of work to be joined.

This simple little jig is extremely useful for routing blind spline slots in spline-mitered frames. Nail or glue together scraps of the frame lumber into the configuration shown in the sketch. The workpiece should fit accurately into the slot, where it can be pinched in place with a clamp. A plunge router is desirable, both for ease of starting the cut and because it has a built-in fence for centering the slot. But I imagine that with a little courage a regular router would do—you could add an integral fence to the jig itself by tacking on more scraps, shimmed with cardboard where necessary. I scribed marks on the jig to show where to start and stop.

—Jim Small, Newville, Pa.

Extracting wooden plugs

To extract a wooden plug, drill a 1/8-in. pilot hole through its center, carefully, so as not to drill into the dowel or screw beneath. Then grind the point off a #8 steel wood screw, and screw it into the hole. When the screw bottoms out, the plug will pop.

—Gerald Kaufman, Halstead, Kan.

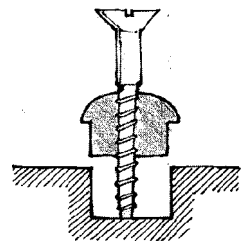

Reground parting tool



I've found that when reground to the shape above, a parting tool cuts cleaner and faster—and is easier to handle, too.

—Howard W. Escher, Seattle, Wash.

Tablesaw jointing fixture

I wouldn't try this setup on a board shorter than 10 ft., but one of the handiest jigs in my shop is a table saw setup for straightening the edges of 1-in. hardwood boards. It does the

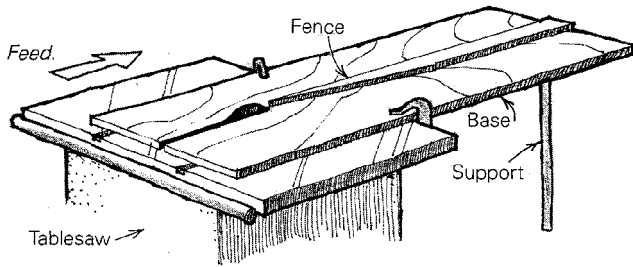

same job as the jointer, but it is faster and more convenient for the 18-ft. boards I use in my boat shop.

To build the jig, joint a 7-ft. long 1x2 and cut a long tapering point on one end. Glue the 1x2 to a 3/4-in. plywood base, about 8 ft. long. Cut a slot in the base in front of the fence for the tablesaw blade.

To use, clamp the fixture to the saw table with the 1x2 fence flush with the left-hand face of the sawblade at its rear edge. Support the tail of the fixture so that it's level. As you pass a board over the sawblade, the waste edge is split away by the long bevel. Press the board tight to the 1x2 fence to get a straight edge.

You do have to freehand the first 6 in. or 7 in. of the cut, as the board must pass the sawblade before it picks up the fence. Freehand cuts can easily kick back, so be careful.

—Colin Pittendrigh, Bozeman, Mont.

Cutting angled rabbets

This simple radial-arm saw method makes it easy to cut mirror-image angled rabbets on the ends of a workpiece, as required for the skirt of a splay-legged table for instance. This

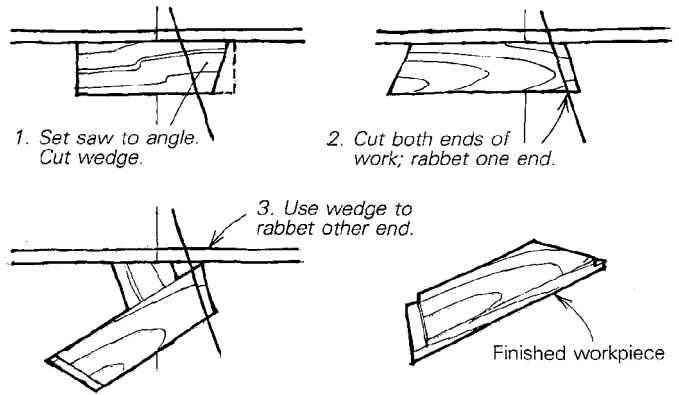

1. Set saw to angle. Cut wedge.

2. Cut both ends of work; rabbet one end.

3. Use wedge to rabbet other end.

Finished workpiece

approach makes it unnecessary to reset the saw to the same angle on the other side for the second cut.

Set the saw to the necessary angle and cut a wedge from a wide piece of waste stock. Don't cut the wedge to a point—the blunt end allows a little overhang, which will be needed. Leaving the arm at the original angle, cut one end of the workpiece, then turn the work over and cut the matching angle on the other end. Next, raise the saw and cut the first rabbet. Finally, place the wedge against the fence and cut the second rabbet, as shown, taking precautions that the workpiece doesn't pivot. The angle is bound to come out right.

—Wendell Davis, Hampton, Conn.

Methods of Work buys readers' tips, jigs and tricks. Send details, sketches (we'll redraw them) and photos to Methods, Fine Woodworking, Box 355, Newtown, Conn. 06470.

T-square router guide

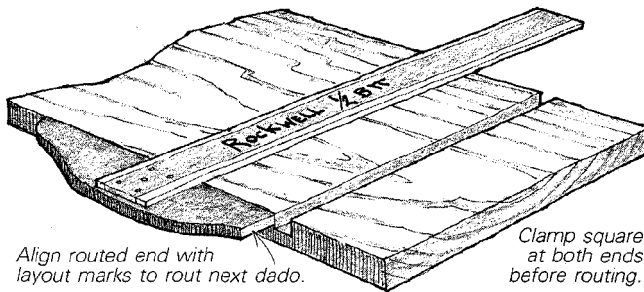

A couple of years back, I grabbed an old drafting T-square for a woodworking student to use as a guide for routing a dado. When he approached the end of the cut, he stopped and told me that if he continued to the edge of the board, he would rout through the head of the square. Since I had a few spares around, I told him to go ahead. When he was finished, we were surprised to find that we had produced, by routing off the tip of the head, a very useful dado guide. The head of the square, now perfectly sized, could be used to align subsequent cuts with the same router and bit.

Now we have eight T-squares with lopped-off heads, each clearly marked as to the router and bit they go with. Four go with different size dados ($\frac{1}{4}$ -in., $\frac{3}{8}$ -in., $\frac{1}{2}$ -in. and $\frac{3}{4}$ -in.) on a Sears router; the other four go with a Rockwell router.

The T-squares are handy for other operations as well. We use them with a $\frac{1}{2}$ -in. carbide bit in the router to "saw" wide or long boards to length if the operation is awkward on the tablesaw. Nothing could be squarer.

—Jeff Sherman, Finn Rock, Ore.

Homebuilt vertical sander

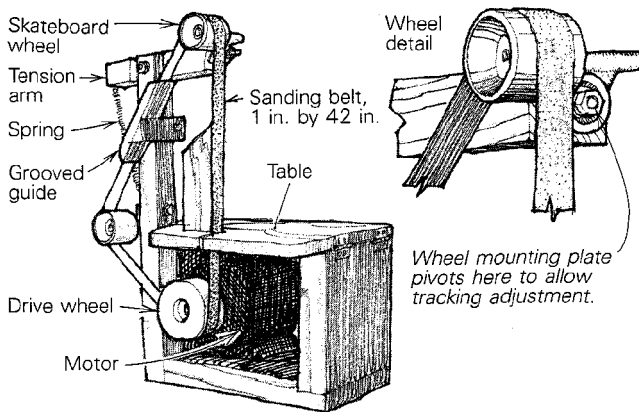

This homebuilt vertical belt sander performs well and is easy on the tool budget. All you need to drive a standard 1-in. by 42-in. belt the proper 1500 to 2,000 FPM (surface feet per minute) is a small 1725-RPM motor, a 3-in. to 4-in. drive pulley, and two slave wheels installed on a frame with a tensioning device.

A satisfactory drive wheel can be turned from wood, or fabricated from a tuna can with both ends cut out. Take a small pulley that fits your motor shaft and epoxy it in the center of the can, being careful not to cover the setscrew on the pulley. For greater traction, wrap the circumference of the drive wheel with duct tape.

For weight and strength, construct the frame from 2-in. thick hardwood. Plywood will suffice for the table. The ten-

sioning arm should fit the vertical support with a pivoting bridal-joint arrangement.

Scavenge the slave wheels from an old skateboard and, using the existing hardware if possible, fasten one wheel to the tensioning arm 12 in. to 15 in. above the drive wheel. Fasten the other slave wheel to the back of the vertical support. Make sure the wheels are attached so that they can pivot to allow the small adjustments needed for alignment and perfect belt-tracking. Other construction details are shown in the sketch.

—Lean O. Beasley, Lafayette, La.

Routing dovetail slots for Shaker tablelegs

Although the Shaker pedestal table design has been around for 150 years, its clean lines have a contemporary feel. Inexpensive to build, the table requires only six wooden parts and a handful of screws. The only construction problem is cutting the sliding-dovetail housings for the legs. The jig shown below solves this problem.

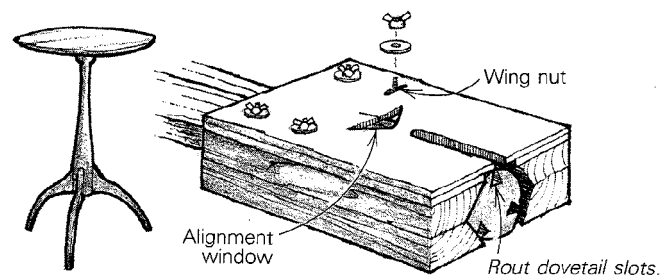

To use the jig, first build up a hexagonal turning blank for the table's stem, chuck it in the lathe and turn the lower 5 in. of the stem to size, leaving the remainder of the blank hexagonal. Now remove the blank from the lathe, mark out the centerlines for the dovetail cuts on three sides of the stem, and mount the jig in place on the workpiece.

The jig has two halves that mate with the hexagonal part of the workpiece, thereby positioning the turned section under the router guide slot. Be sure that the marked centerline on the blank is correctly positioned in the alignment window.

A bench vise holds the entire setup. Start by hogging out all three dovetail slots with a $\frac{3}{8}$ -in. straight bit. Use your router's guide bushing to guide the cut. Next, clean out the slots with a dovetail bit. After the dovetail slots have been cut, return the stem to the lathe to complete the turning.

—Bernie Maas, Cambridge Springs, Pa.

Contour sander

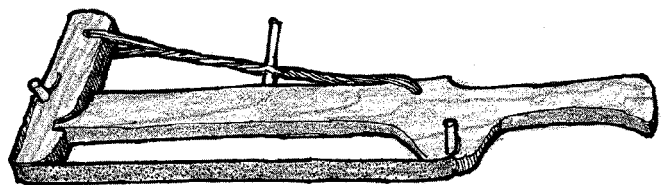

This shopmade sander for lathe work and curves uses a length of abrasive cloth tensioned, bowsaw fashion, by a twisted cord. The abrasive cloth, which can be purchased in $\frac{3}{4}$ -in. or $1\frac{1}{2}$ -in. width rolls, is clamped into the sander with tight-fitting dowel pegs.

—Richard Tolzman, Excelsior, Minn.

Vacuum clamping system

If you have a central dust-collection system in your shop, a simple addition to it will provide a useful clamping system. Cut a 5-in. hole through the top of your bench, rabbet the

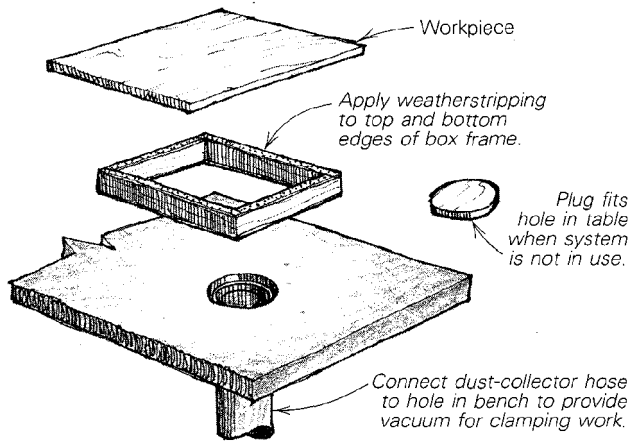

edge of the hole with a router, and cut a hardwood plug to fit flush—it will leave the bench smooth when you're not using the clamp. Connect your dust-collection system to the bottom of the hole with whatever piping is necessary.

To use the clamp, make a box frame, and cover the top and bottom edges with self-adhesive foam weatherstripping. Place the box on the bench over the hole, place the workpiece on top of the box, and turn the vacuum on. The workpiece will be held firmly for edge-routing, sanding and other operations, with nothing to obstruct work on all four edges. Because of the padding offered by the weatherstripping, this is an ideal way to hold flat panels for sanding between coats of finish. The hole in the bench has a side benefit: it makes cleaning shavings off the bench easier and faster.

—Mac Campbell, Harvey Station, N.B.

Stabilizing tall candlesticks

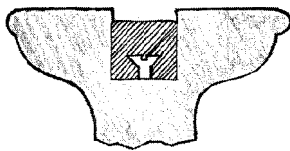

To stabilize tall wooden candlesticks, I pour molten lead into a $\frac{3}{4}$ -in. by 1-in. hole bored in the bottom. If you start a screw in the hole and pour the metal around it, the lead will stay in position. To avoid burning the

wood, I cut the lead into small ingots that I can heat with a propane torch and I drip the lead into the hole one drop at a time. Old wheel-balancing weights from a gas station are good raw material.

—Eric Schramm, Los Gatos, Calif.

Miniature log-house joint

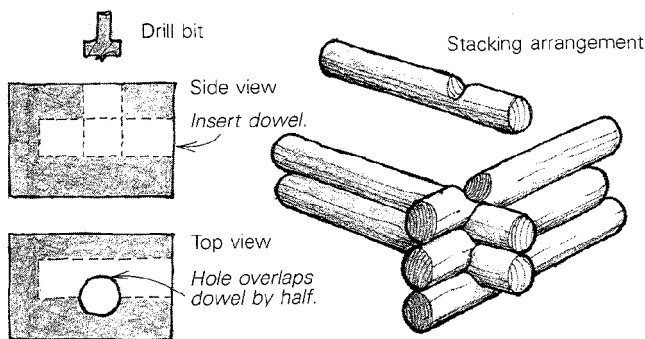

This simple little jig makes joints on dowels or short tree branches for a miniature log house. Choose a drill bit the same size as the dowels or sticks to be used in the house, then drill a block of wood from two sides, with the second hole overlapping half of the first. To use, insert a dowel in the first

hole and use the other as a guide for the drill bit. Note that the distance between the overlap and the end of the first hole will determine the overhang of the miniature logs, which assemble as shown in the sketch.

—Gerald Robertson, Angus, Ont.

"Poor boy" radial-arm saw

For crosscutting long boards and making miter cuts, this shopmade saw guide is accurate, portable, easy to use and economical to build.

The guide is simply an angle-iron and plywood track sized to fit the base of a portable circular saw. The guide is perched atop legs at each end. Each leg is made from a pair of $3\frac{1}{2}$ -in. pipe flanges connected by a $\frac{3}{4}$ -in. by $1\frac{1}{2}$ -in. pipe nipple. The legs provide clearance for the work and allow the track to pivot for making angle cuts.

To use, damp the guide at the proper angle in relation to the fence on the plywood base. Before cutting, secure the saw's blade guard up out of the way with a screw threaded through a hole in the blade housing. Make sure you remove the screw before the saw is used in the conventional manner.

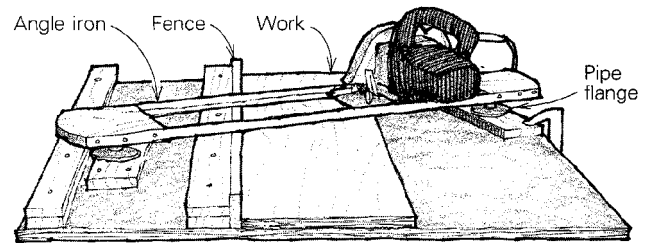

Another note of caution: The direction of blade rotation tends to lift the work from the table, so make sure the work is tight against the fence and can't shift. Otherwise, the work might pinch the sawblade and cause the saw to lift out of the guide rails.

On my $7\frac{1}{4}$ -in. saw, the depth of cut is limited to $1\frac{3}{4}$ in., but this covers most of the crosscutting work I do.

—Jack Fisher, Dayton, Ohio

Shopmade tool rests

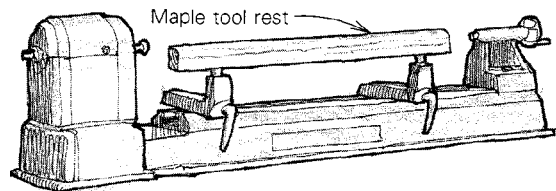

Roughing down a whole turning at once is such a pleasure that I've made a series of hard-maple tool rests in various lengths. I use them instead of the skimpy metal rest that came with my lathe. Support the wooden rest with a metal post that fits your current tool rest's base. For long tool rests, you'll need more than one base.

—Jim Ryerson, Guelph, Ont.

Keeping padauk's color

Many woods that have brilliant color when freshly cut, padauk for example, will darken and turn brown in time. Bruce Hoadley points out that the major culprit in this color change is ultraviolet light. To shield the wood from ultraviolet light and thus effectively slow the darkening process, I use a product called Armor-All, a spray-on protective liquid for auto

vinyl. This product, available at auto supply stores, is quite effective—I have yet to see the color of padauk change, even after four years. To use, spray three or four coats of Armor-All on the wood before you apply the finish. I use an oil finish, which is compatible with Armor-All, but other finishes such as lacquer or varnish may not be. You'd best test the particular finish you plan to use.

—David Lewis, Phoenix, Ariz.



Masking-tape drill stop

The best depth stop for a portable electric drill is a masking-tape flag around the bit stem, as shown in the drawing. Masking tape works on all kinds of bits, is easy to set to the right depth, and never mars the workpiece. The advantage of the flag is that you don't have to strain your eyes to tell when the tape reaches the surface—you simply stop drilling when the flag sweeps the chips away.

—Richard R. Krueger, Seattle, Wash.,
and Norman Crowfoot, Pinetop, Ariz.

Stopping sandpaper gumming

If your sandpaper loads up with residue when you're sanding wood that has been stripped, for example, throw some pumice-stone powder on the work. The paper will keep working and won't load up, and the abrasive will stay sharp longer. Add more pumice as needed.

—Jon Gullett, Washington, Ill.

Bandsaw rip fence adjusts for drift

Pivot fence to match blade's drift angle, then tighten wing nut to hold adjustment until next blade change.

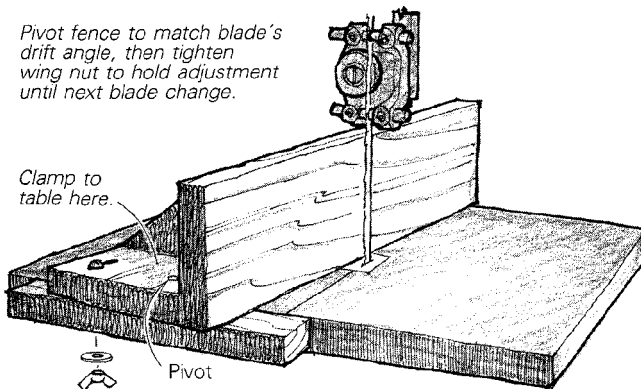

Those who use the bandsaw for ripping and resawing know that each blade has its own line of cut, which is rarely parallel to the fence. This shopmade rip fence reduces the time-consuming chore of redetermining the drift angle every time you move the fence. The base damps to the front of the table, and the fence itself pivots and locks as shown in the sketch, allowing you to set the drift angle into the fence.

To set the guide, first determine the drift angle by free-hand ripping a piece of waste stock. Feed the board, angling it until the blade tracks straight down its center. Transfer the drift angle from the board to the adjustable rip fence with a T-bevel. Tighten the guide at the angle, and the drift is set into the fence until the next blade change.

—Richard Farwell, San Luis Obispo, Calif.

Methods of Work buys readers' tips, jigs and tricks. Send details, sketches (we'll redraw them) and photos to Methods, Fine Woodworking, Box 355, Newtown, Conn. 06470. We'll acknowledge contributions when the final decision has been made, and return those with an SASE.

T-square router guide

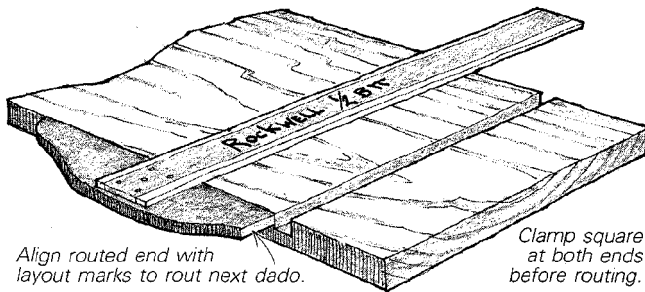

A couple of years back, I grabbed an old drafting T-square for a woodworking student to use as a guide for routing a dado. When he approached the end of the cut, he stopped and told me that if he continued to the edge of the board, he would rout through the head of the square. Since I had a few spares around, I told him to go ahead. When he was finished, we were surprised to find that we had produced, by routing off the tip of the head, a very useful dado guide. The head of the square, now perfectly sized, could be used to align subsequent cuts with the same router and bit.

Now we have eight T-squares with lopped-off heads, each clearly marked as to the router and bit they go with. Four go with different size dados ($\frac{1}{4}$ -in., $\frac{3}{8}$ -in., $\frac{1}{2}$ -in. and $\frac{3}{4}$ -in.) on a Sears router; the other four go with a Rockwell router.

The T-squares are handy for other operations as well. We use them with a $\frac{1}{2}$ -in. carbide bit in the router to "saw" wide or long boards to length if the operation is awkward on the tablesaw. Nothing could be squarer.

—Jeff Sherman, Finn Rock, Ore.

Homebuilt vertical sander

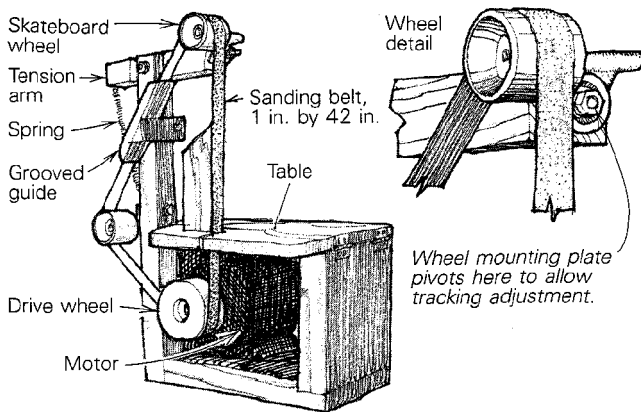

This homebuilt vertical belt sander performs well and is easy on the tool budget. All you need to drive a standard 1-in. by 42-in. belt the proper 1500 to 2,000 FPM (surface feet per minute) is a small 1725-RPM motor, a 3-in. to 4-in. drive pulley, and two slave wheels installed on a frame with a tensioning device.

A satisfactory drive wheel can be turned from wood, or fabricated from a tuna can with both ends cut out. Take a small pulley that fits your motor shaft and epoxy it in the center of the can, being careful not to cover the setscrew on the pulley. For greater traction, wrap the circumference of the drive wheel with duct tape.

For weight and strength, construct the frame from 2-in. thick hardwood. Plywood will suffice for the table. The ten-

sioning arm should fit the vertical support with a pivoting bridal-joint arrangement.

Scavenge the slave wheels from an old skateboard and, using the existing hardware if possible, fasten one wheel to the tensioning arm 12 in. to 15 in. above the drive wheel. Fasten the other slave wheel to the back of the vertical support. Make sure the wheels are attached so that they can pivot to allow the small adjustments needed for alignment and perfect belt-tracking. Other construction details are shown in the sketch.

—Lean O. Beasley, Lafayette, La.

Routing dovetail slots for Shaker tablelegs

Although the Shaker pedestal table design has been around for 150 years, its clean lines have a contemporary feel. Inexpensive to build, the table requires only six wooden parts and a handful of screws. The only construction problem is cutting the sliding-dovetail housings for the legs. The jig shown below solves this problem.

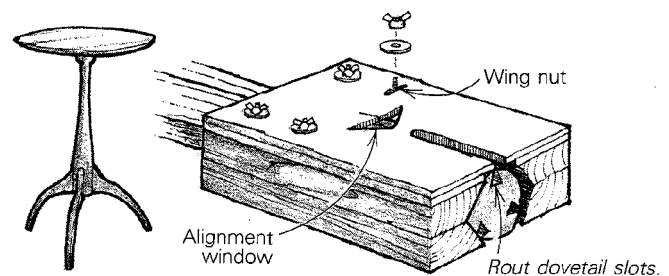

To use the jig, first build up a hexagonal turning blank for the table's stem, chuck it in the lathe and turn the lower 5 in. of the stem to size, leaving the remainder of the blank hexagonal. Now remove the blank from the lathe, mark out the centerlines for the dovetail cuts on three sides of the stem, and mount the jig in place on the workpiece.

The jig has two halves that mate with the hexagonal part of the workpiece, thereby positioning the turned section under the router guide slot. Be sure that the marked centerline on the blank is correctly positioned in the alignment window.

A bench vise holds the entire setup. Start by hogging out all three dovetail slots with a $\frac{3}{8}$ -in. straight bit. Use your router's guide bushing to guide the cut. Next, clean out the slots with a dovetail bit. After the dovetail slots have been cut, return the stem to the lathe to complete the turning.

—Bernie Maas, Cambridge Springs, Pa.

Contour sander

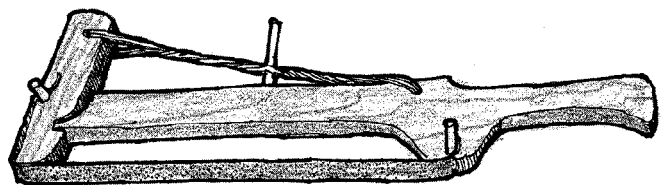

This shopmade sander for lathe work and curves uses a length of abrasive cloth tensioned, bowsaw fashion, by a twisted cord. The abrasive cloth, which can be purchased in $\frac{3}{4}$ -in. or $1\frac{1}{2}$ -in. width rolls, is clamped into the sander with tight-fitting dowel pegs.

—Richard Tolzman, Excelsior, Minn.

Vacuum clamping system

If you have a central dust-collection system in your shop, a simple addition to it will provide a useful clamping system. Cut a 5-in. hole through the top of your bench, rabbet the

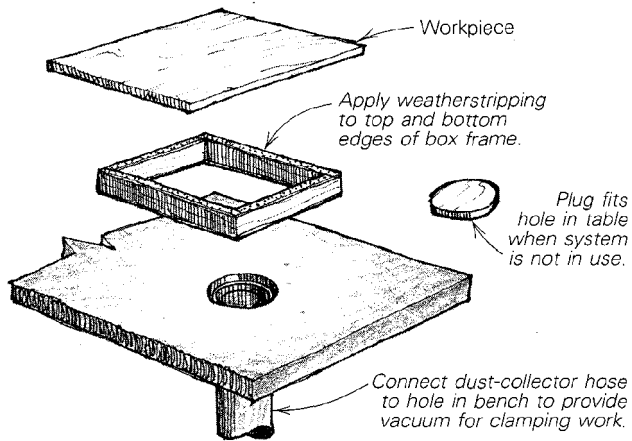

edge of the hole with a router, and cut a hardwood plug to fit flush—it will leave the bench smooth when you're not using the clamp. Connect your dust-collection system to the bottom of the hole with whatever piping is necessary.

To use the clamp, make a box frame, and cover the top and bottom edges with self-adhesive foam weatherstripping. Place the box on the bench over the hole, place the workpiece on top of the box, and turn the vacuum on. The workpiece will be held firmly for edge-routing, sanding and other operations, with nothing to obstruct work on all four edges. Because of the padding offered by the weatherstripping, this is an ideal way to hold flat panels for sanding between coats of finish. The hole in the bench has a side benefit: it makes cleaning shavings off the bench easier and faster.

—Mac Campbell, Harvey Station, N.B.

Stabilizing tall candlesticks

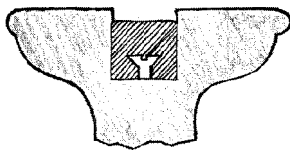

To stabilize tall wooden candlesticks, I pour molten lead into a $\frac{3}{4}$ -in. by 1-in. hole bored in the bottom. If you start a screw in the hole and pour the metal around it, the lead will stay in position. To avoid burning the

wood, I cut the lead into small ingots that I can heat with a propane torch and I drip the lead into the hole one drop at a time. Old wheel-balancing weights from a gas station are good raw material.

—Eric Schramm, Los Gatos, Calif.

Miniature log-house joint

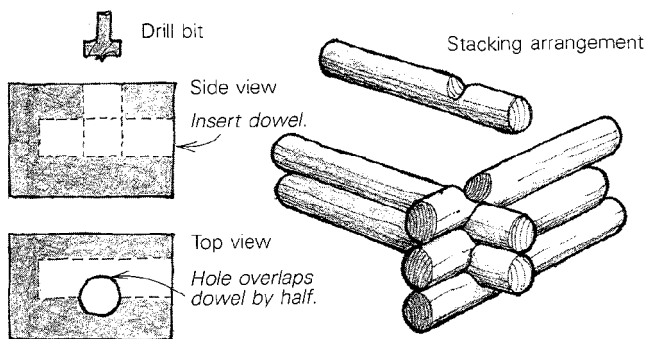

This simple little jig makes joints on dowels or short tree branches for a miniature log house. Choose a drill bit the same size as the dowels or sticks to be used in the house, then drill a block of wood from two sides, with the second hole overlapping half of the first. To use, insert a dowel in the first

hole and use the other as a guide for the drill bit. Note that the distance between the overlap and the end of the first hole will determine the overhang of the miniature logs, which assemble as shown in the sketch.

—Gerald Robertson, Angus, Ont.

"Poor boy" radial-arm saw

For crosscutting long boards and making miter cuts, this shopmade saw guide is accurate, portable, easy to use and economical to build.

The guide is simply an angle-iron and plywood track sized to fit the base of a portable circular saw. The guide is perched atop legs at each end. Each leg is made from a pair of $3\frac{1}{2}$ -in. pipe flanges connected by a $\frac{3}{4}$ -in. by $1\frac{1}{2}$ -in. pipe nipple. The legs provide clearance for the work and allow the track to pivot for making angle cuts.

To use, damp the guide at the proper angle in relation to the fence on the plywood base. Before cutting, secure the saw's blade guard up out of the way with a screw threaded through a hole in the blade housing. Make sure you remove the screw before the saw is used in the conventional manner.

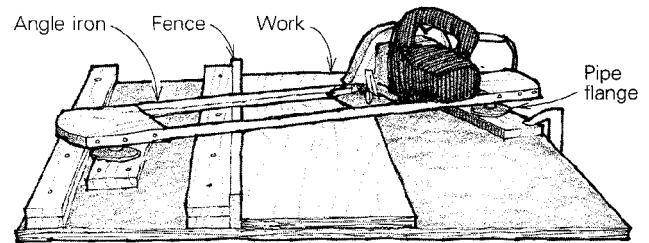

Another note of caution: The direction of blade rotation tends to lift the work from the table, so make sure the work is tight against the fence and can't shift. Otherwise, the work might pinch the sawblade and cause the saw to lift out of the guide rails.

On my $7\frac{1}{4}$ -in. saw, the depth of cut is limited to $1\frac{3}{4}$ in., but this covers most of the crosscutting work I do.

—Jack Fisher, Dayton, Ohio

Shopmade tool rests

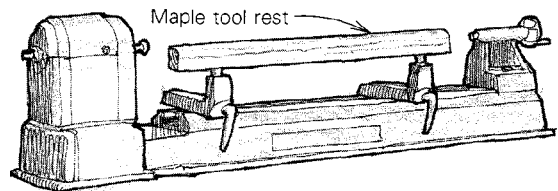

Roughing down a whole turning at once is such a pleasure that I've made a series of hard-maple tool rests in various lengths. I use them instead of the skimpy metal rest that came with my lathe. Support the wooden rest with a metal post that fits your current tool rest's base. For long tool rests, you'll need more than one base.

—Jim Ryerson, Guelph, Ont.

Keeping padauk's color

Many woods that have brilliant color when freshly cut, padauk for example, will darken and turn brown in time. Bruce Hoadley points out that the major culprit in this color change is ultraviolet light. To shield the wood from ultraviolet light and thus effectively slow the darkening process, I use a product called Armor-All, a spray-on protective liquid for auto

vinyl. This product, available at auto supply stores, is quite effective—I have yet to see the color of padauk change, even after four years. To use, spray three or four coats of Armor-All on the wood before you apply the finish. I use an oil finish, which is compatible with Armor-All, but other finishes such as lacquer or varnish may not be. You'd best test the particular finish you plan to use.

—David Lewis, Phoenix, Ariz.



Masking-tape drill stop

The best depth stop for a portable electric drill is a masking-tape flag around the bit stem, as shown in the drawing. Masking tape works on all kinds of bits, is easy to set to the right depth, and never mars the workpiece. The advantage of the flag is that you don't have to strain your eyes to tell when the tape reaches the surface—you simply stop drilling when the flag sweeps the chips away.

—Richard R. Krueger, Seattle, Wash.,
and Norman Crowfoot, Pinetop, Ariz.

Stopping sandpaper gumming

If your sandpaper loads up with residue when you're sanding wood that has been stripped, for example, throw some pumice-stone powder on the work. The paper will keep working and won't load up, and the abrasive will stay sharp longer. Add more pumice as needed.

—Jon Gullett, Washington, Ill.

Bandsaw rip fence adjusts for drift

Pivot fence to match blade's drift angle, then tighten wing nut to hold adjustment until next blade change.

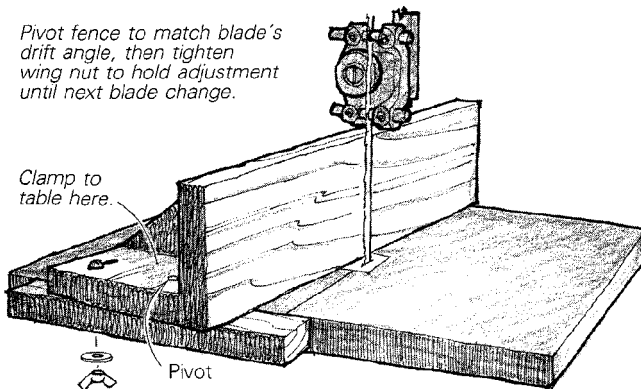

Those who use the bandsaw for ripping and resawing know that each blade has its own line of cut, which is rarely parallel to the fence. This shopmade rip fence reduces the time-consuming chore of redetermining the drift angle every time you move the fence. The base damps to the front of the table, and the fence itself pivots and locks as shown in the sketch, allowing you to set the drift angle into the fence.

To set the guide, first determine the drift angle by free-hand ripping a piece of waste stock. Feed the board, angling it until the blade tracks straight down its center. Transfer the drift angle from the board to the adjustable rip fence with a T-bevel. Tighten the guide at the angle, and the drift is set into the fence until the next blade change.

—Richard Farwell, San Luis Obispo, Calif.

Methods of Work buys readers' tips, jigs and tricks. Send details, sketches (we'll redraw them) and photos to Methods, Fine Woodworking, Box 355, Newtown, Conn. 06470. We'll acknowledge contributions when the final decision has been made, and return those with an SASE.

Bandsawn multiples

To fill an order for four round-head window frames, we had to cut more than a hundred identically curved blocks to build up the curves in brick-wall fashion. The bandsaw jig shown here allowed us to cut the blocks quickly and accurately.

First cut a true-to-size pattern and install screws through it so that the sharpened points protrude about $\frac{1}{4}$ in. Next cut two curved fences (one convex, the other concave) to the radius of the pattern. Clamp the fences to the bandsaw table, leaving a gap the width of the pattern on each side of the blade, as shown in the sketch.

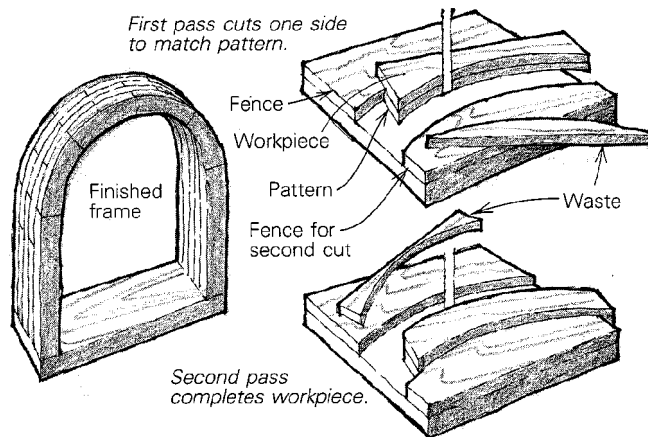

To use the setup, press a blank on top of the pattern, with the screw points holding it in place. To cut the first edge, push the blank through the bandsaw with the pattern riding the concave fence. On the other side of the blade, cut the second edge with the pattern riding the convex fence. Each workpiece will be identical to the pattern.

—William D. Handley, Bishopville, Md.

EDITOR'S NOTE: For other patternsawing setups, see pp. 54-55.

Locking stop block

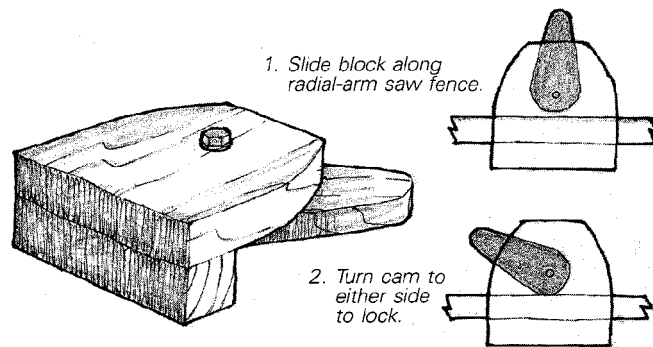

I made this cam-locking stop block for my radial-arm saw because I often have to cut many boards to the same length. Simply slide the fixture along the fence until it's at the right position, then lock it in place by rotating the cam lever. I left a little room under the face of the block for chip clearance. The fixture works on either side of the blade.

—Orville Otis, Coldwater, Mich.

Stop hinges for jewelry boxes

Unable to locate solid-brass stop hinges for jewelry boxes, at any price, I decided to make my own. With David Sloan's article on making brass hardware (*FWW* #41) as a guide, I soldered a $\frac{1}{16}$ -in. brass rod across the back of two solid-brass

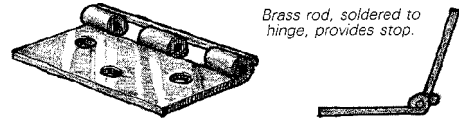

leaf hinges. This rod neatly stops the lid, is unobtrusive, and is, I think, a more elegant solution than a stop chain.

I found the brass rod at a hobby shop, and the silver solder—in a package with the proper flux—at the hardware store. The only trick is holding things in place during soldering. First I separated the hinges by pulling the pins and clamped the two bottom leaves side-by-side in a vise. I held the brass rod in place with locking soldering tweezers (available at Radio Shack stores). Setting up both leaves at once with a single length of rod helps to match the rod's position on both hinges. After the solder has cooled, you can cut the rod to separate the two leaves and then file away any excess solder.

—Jack Warner, Atlanta, Ga.

Turning without a lathe

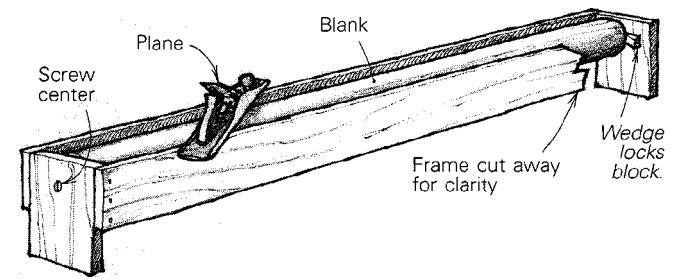

If you've got a 4-ft. post to turn and only a 3-ft. bed on your lathe, the drawing shows a way out of the dilemma. Bandsaw or tablesaw the blank octagonal, mount it in a scrapwood cradle and plane it round. Position the wood-screw mounting centers the desired radius beneath the parallel sides of the cradle. The final strokes of the plane will rest on the sides of the cradle to ensure a uniform and accurate circumference.

—Blaine Foule, Lincoln, Neb.

Installing threaded inserts

I ran into great difficulty trying to drive threaded inserts into rock maple (sugar maple). The screw-driver slots kept shearing off under the pressure of screwing the inserts into the hard wood. As shown in the drawing, to avoid this problem I now use a hex-head bolt and jamb nut to install the inserts. Simply thread the nut on the bolt, then follow with the insert. The insert can now be driven home easily with a socket and ratchet. Back out the bolt when the insert is in place.

—Timothy H. Doggett, Juneau, Alaska

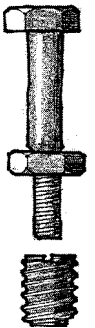

Installing box hinges, two ways

In a recent issue (*FWW* #44), Jack Warner asked for tips on installing hinges on small boxes so that the top and bottom are aligned. Here's a system I've used with good results. First install the hinges to either the top or the bottom. Make three marking points by chucking a properly sized flat-head wood screw in a lathe (or electric drill) and cutting off the head with a file to form a pointed cone. Place the three cone-shaped points between the leaves of one of the hinges, so that they point out through their screw holes—they will automatically center themselves. Locate the cover on the box and press

it down when it is perfectly aligned. The points of the cones will leave indentations to mark drill locations. Install the first hinge, then repeat the operation for the second hinge. Scribe and cut the hinge-leaf mortises when you are sure of their exact location. —*M.O. Nichols, Black River Falls, Wis.*
 After mounting the hinges to the box bottom, I insert a rectangle of foam rubber about $\frac{1}{8}$ in. thick between the hinge leaves. This forces the hinges open slightly. Then I smear a dab of 5-minute epoxy on the top surface of the hinges, put the top in place and hold it down with a weight. The foam rubber "spring" exerts enough pressure to ensure a rest bond between the hinges and the top. When the epoxy sets, I open the box, remove the foam rubber and install the remaining screws. —*L. Feldberg, Spring Valley, N.Y.*

Clamp perch for round tabletops

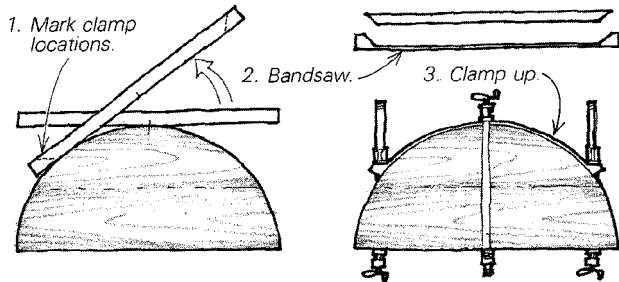

Few things provoke language unbecoming a woodworker more than trying to clamp up a round tabletop. On a restoration project, I found myself having to rejoin and reglue the boards in two half-round top sections of a table. Cussin' didn't work, so I devised another scheme.

I scrounged up a nice straight-grained piece of ash about $\frac{3}{4}$ in. thick, and marked the center point on it and on the top of the curve of the outside table board. Then, rolling the stick along the circumference, I marked out perch points at appropriate clamping places—the sketch shows one at each end, but you can make as many as you think you need—taking care to keep the flats parallel to the centerline of the table. Then I bandsawed the ash down to a springy $\frac{1}{4}$ in., leaving the perch spots as shown. To use, I bar-clamped the stick first in the middle, applying enough pressure so that it wouldn't slip. Then, working out from the middle, I bent the stick around the curve and gradually snugged up the clamps on each flat. —*Jim Small, Neville, Pa.*

Routing deep through mortises

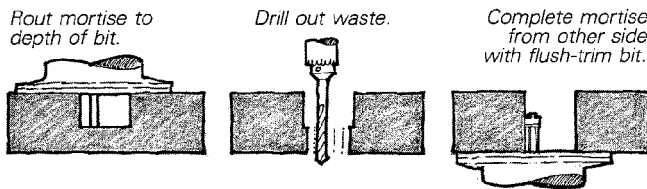

Here's a simple but effective way to cut deep through mortises. First rout the mortise halfway through from the face edge of the stock. Then drill out the majority of the waste through the member. Mount a ball-bearing flush-trim bit in the router and clean up the mortise from the back edge of the stock. Be sure the trimmer bit's bearing is deep enough to ride on the dressed portion of the mortise. Of course, you will have to square out the corners by hand.

—*Patrick Warner, Escondido, Calif.*

Low-cost power hone

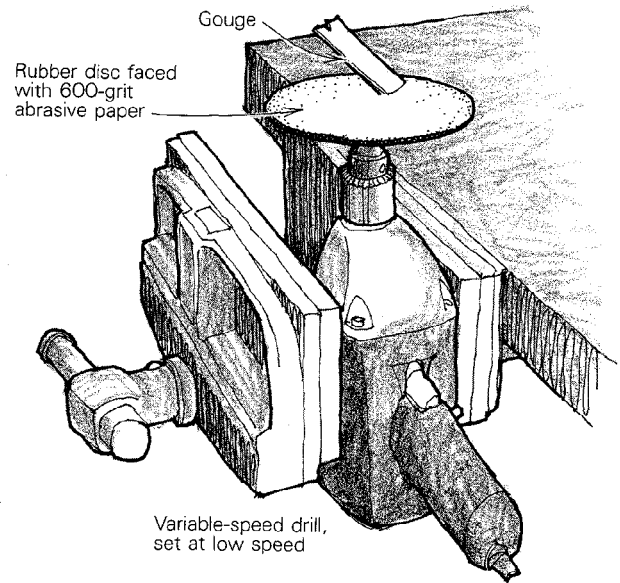

This low-cost hone will put a mirror-finish razor edge on gouges and chisels. You'll need a variable-speed hand drill, a 6-in. rubber sanding disc, a sheet of 600-grit wet-or-dry abrasive paper and mineral oil. Clamp the drill upright in the vise (not too tight or you'll distort the case). Cut a circle from the abrasive paper and fasten it to the sanding disc with rubber cement.

To use, set the drill for a low speed and lock it on. Apply a few drops of oil to the paper and proceed to hone. At a low speed there's little chance of overheating the edge. I get best results with the paper turning into the blade.

—*Jim Van Fossen, N. Ridgeville, Ohio*

Outdoor workbench

I made a version of the outdoor workbench shown in *FWW* #33, p. 18, by substituting a sliding-head pipe clamp for the bench hold-down, and it works like a charm—hardly a day goes by that I don't use this bench. Instead of tying up a whole clamp, I took just the sliding head from the standard clamp (which has a fixed foot at the other end, fits $\frac{3}{4}$ -in. pipe, and is available from Constantine's) and attached a different piece of pipe to the log with metal straps at the side and over a standard pipe elbow at the bottom, which grips the log for purchase. This way, I can take the head indoors with me at the end of the day to avoid rusting, and I can slide it back onto its regular pipe for other projects, too. As a bonus, I find that the pipe sticking up makes it easy to shift the block around. —*Don Anderson, Sequim, Wash.*

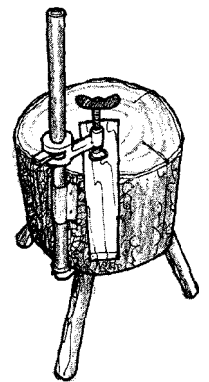

Routing European-hinge mortises

Several years ago, I remodeled my kitchen and painstakingly arrived at many of the details presented in Bill Pfeiffer's European-style cabinets article (*FWW* #43). I have neither a drill press nor the $1\frac{3}{8}$ -in. Forstner bit with which he bores the large mortises for the door hinges. Instead, I made a router jig that did the job. To calculate the diameter of the cutout in the jig, add the router-base diameter to the mortise diameter,

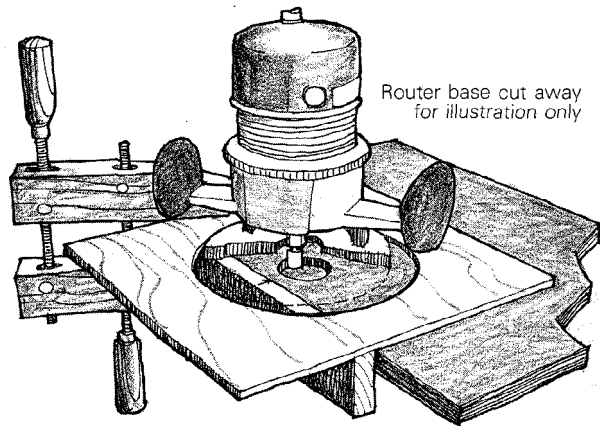

then subtract the diameter of the router bit. For example, if the diameter of the router base is 6 in., the mortise diameter $1\frac{3}{8}$ in. and the router-bit diameter $\frac{1}{2}$ in., the cutout diameter should be 6 plus $1\frac{3}{8}$ minus $\frac{1}{2}$, which equals $6\frac{7}{8}$ in.

To rout the mortise, lock the jig in place with handscrews, lower the router base into the cutout, and move the router around and to and fro. To avoid overloading, especially with a light-duty router, make several passes, lowering the bit gradually to final depth. —Grant D. Miller, Reno, Nev.

Methods of Work buys readers' tips, jigs and tricks. Send details, sketches (we'll redraw them) and photos to Methods, Fine Woodworking, Box 355, Newtown, Conn. 06470. We'll acknowledge contributions when the final decision has been made, and return those with SASE.

Quick Tips

If you don't have a band clamp and need one, you can build up great pressure by clamping things with ordinary braided nylon cord. Each turn around the work adds more pressure.

—Howard C. Lawrence, Cherry Hill, NJ.

To make a turning square from a rectangular scrap, I use the narrow dimension to set the handsaw's fence, rip the blank square, and then make two light cuts from corner to corner on each end of the blank. These provide kerfs for the headstock's spur center to grip, and the intersection, of course, marks the exact center for the tailstock. —L. Green, Bethel, Conn.

When turning, you can scribe critical lengths with a simple gauge. In a piece of scrap, drive screws the correct distance apart so that their points protrude, then press this against the roughed-out cylinder. —Jim Ryerson, Guelph, Ont.

When making threaded dowels, I had considerable trouble because the threads kept breaking out in chunks. The solution is to reduce the diameter of the dowels slightly (about $\frac{1}{64}$ in.), then soak them in water for half an hour before threading.

—O.L. Williams, Lincoln, Neb.

My dust-removal system is an ordinary vacuum with a strong magnet clamped to its nozzle. The magnet holds the nozzle just where I need it on most of my stationary machines.

—George Kramer, Ashland, Ore.

CORRECTION: In Edward M. Rosenfeld's Method of Work, "Raising panels with the router" (FWW #45, p. 10), there are four rods in the router base, not two. Hence there is no problem disassembling the jig.

Rip-fence extensions, two ways

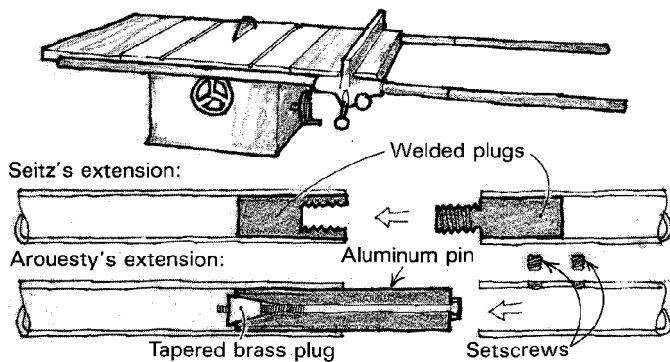

My decision to extend the rip-fence tails on my Rockwell contractors' tablesaw came after a 4x8 sheet of plywood I was cutting "freehand" kicked back on me. I removed the tubular rails, took them to a machinist, and asked him to extend them so I could easily set the fence up to 48 in. The machinist welded a 2-in. steel plug in the end of each rail, drilled a $\frac{3}{4}$ -in. hole through the plug, then tapped the hole with a coarse thread. He made the 24-in. extensions from tubular steel the same size as the rails and fitted each extension with a thread that screws into the plug in the original rails. These extensions have saved me countless hours of production time.

—Stephen Seitz, Oleyo, N.Y.

To extend the rails on my Rockwell tablesaw, I purchased a second set of tubular rails and devised expanding aluminum pins to attach them to the original rails. I drilled a bolt hole through the length of each pin and slotted the inner end, as shown in the sketch, so it could expand to lock the pin in the rail. With the pins locked into the original rails, I slip the spare rails on and fasten them in place with setscrews, which are located on the inside so they'll clear the rip fence.

I'm pleased with this system because I can remove the rails when they're not in use and I can use the saw's racking "micro-adjustment" mechanism all the way across.

—Raymond Arouesty, Reseda, Calif.

Quick tip: Sanding-belt cleaners work great, but you don't have to shell out \$10 for the commercial version. Just rip the soles from some discarded desert boots or other shoes with crepe-rubber soles.

—Greg Kindig, Harrington, Del.

Shopmade pull saw

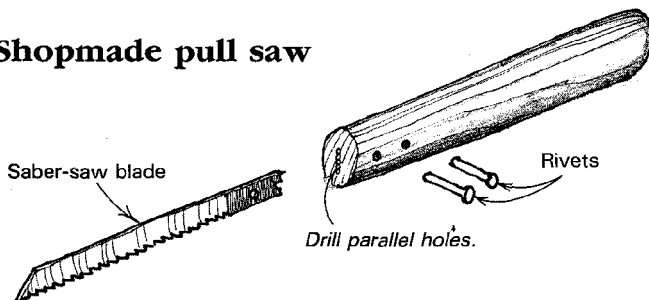

I don't own a saber saw, but I do buy the blades—they make the handiest small saws in my shop.

First, choose a drill bit the same thickness as the sawblade and drill four or five holes side-by-side in the end of the handle blank. Using the blade as a template, mark the location of the rivet holes on the side of the blank. Now clamp the blade upright in a vise and tap the handle over it. Drill holes where marked, rivet the blade securely in place, and shape the handle to suit.

—Stefan During, Texel, Holland

Thickness-planing on the jointer

Tage Frid, in *FWW* #19, p. 94, describes how to thickness boards on the jointer. Frid's jig is a precision wooden affair that requires removing the jointer's fence to work. Here's a simpler way. From a signmaker obtain two 1-in. strips of flexible magnetic sign backing and glue each to a hardwood strip to produce two $\frac{1}{2}$ -in. thick sticks as long as the infeed table. Glue a hardwood block on the end of each strip to keep it from creeping into the cutterhead.

Before using the setup, first joint one face and both edges of the board to be thicknessed. Rabbet the edges, as shown on the workpiece in the sketch.

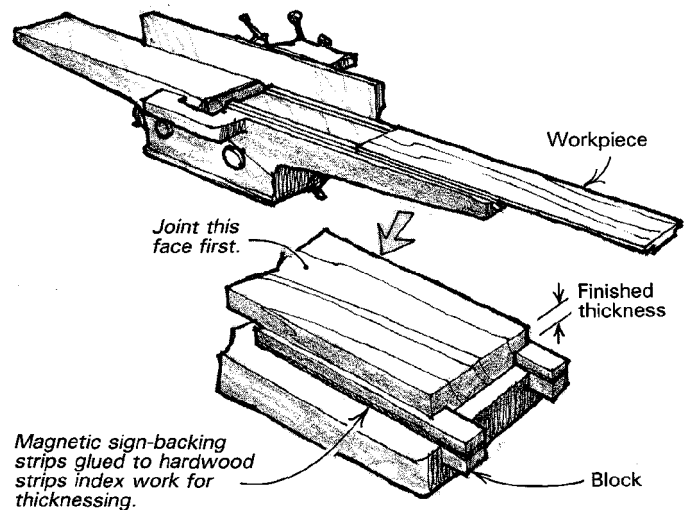

Now snap the two strips in place on the infeed table so the rabbets ride the strips like rails. Run the workpiece down the rails, across the cutterhead and onto the outfeed table. In this manner, it is the uniform rabbet that indexes the work; the irregular face doesn't touch the infeed table at all. Start with a light cut, then gradually lower the infeed table with each pass until the rabbets are only $\frac{1}{16}$ in. deep. On the last pass, just skim off the wood down to the rabbets to produce the final thickness.

The magnetic strips can be easily adjusted to different-width boards, and there's no need to remove the jointer's fence to use them. When the job is done, it takes all of three seconds to convert your thickness planer back to a jointer.

—Robert Edmondson, Bowmanville, Ont.

Quick tip: I made my router table with a plywood top and a pair of sawhorses as legs. In order to allow easy knockdown, the tops of the sawhorses simply fit into dadoes beneath the plywood. This gives me a little more room in the shop when needed and frees the sawhorses when I want to use them for other things. The table has a spare router base permanently attached—the router can quickly slip out of this, put on its other bottom, and be ready to tackle other jobs. Best of all, I made the table the same height as my tablesaw, so it can double as an outfeed table, which is actually how the whole idea started.

—Ed Devlin, Rothsay, Minn.

Homebuilt outboard lathe

Turning circular tabletops on my regular lathe was less than satisfactory. The outboard spindle was just not designed for large, unbalanced, rough work. When a friend offered me a rear wheel and axle bearing from a front-wheel-drive car (G.M. No. 1-7466906), my ideas for a special homebuilt outboard lathe came together. I figured that if the hub could

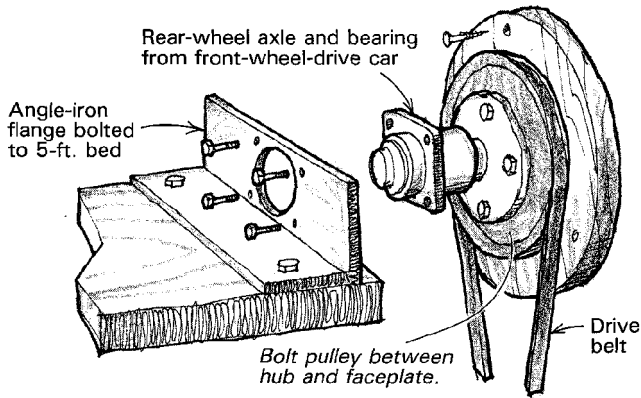

handle a car wheel, it would be ideal for turning a tabletop.

I bolted the wheel assembly's brake flange to a 12-in. long section of $\frac{1}{4}$ -in. thick, 3x3 angle iron as shown, and lag-screwed this to a rigid yellow-pine bed about 5 ft. long.

The lathe faceplate is a 1-in. thick, 11-in. dia. oak disc. I bolted the faceplate directly to the hub with a 9-in. pulley sandwiched between. The headstock/pulley assembly is permanent, and after installation the faceplate should be trued round and faced flat.

To power the lathe, I mounted a $\frac{1}{2}$ -HP, 1725-RPM motor with a 2-in. drive pulley.

The easiest way to fasten the work to the lathe headstock is to drive screws through the rim from the back side. Of course, more elaborate faceplate-fastening techniques can be designed for special projects if needed.

Even on the first project, the lathe exceeded my expectations with its quiet, vibration-free performance.

—Lawrence Wachsenheim, Quincy, Ill.

Wall-mounting cabinets

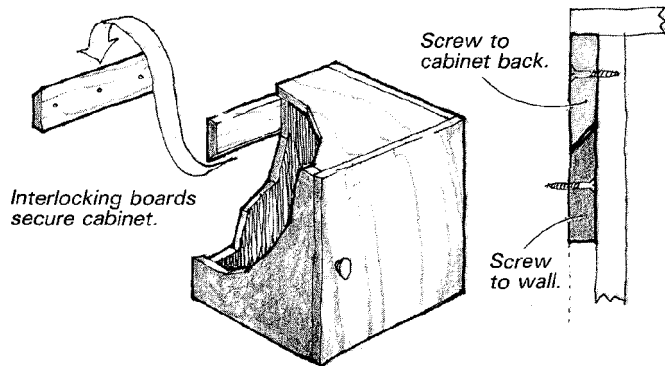

This simple method for hanging wall cabinets is fast, easy and accurate. To make the mount, rip a $\frac{3}{4}$ -in. thick board in two at a 45° angle. Screw one half to the wall to form a perch and screw the other half to the cabinet back, which should be recessed $\frac{3}{4}$ in., as shown. Then just slip the cabinet over the perch board—a one-man operation. As a bonus, the cabinet can be easily removed whenever needed.

—George C. Muller, Union, N.J.

Bowlturning chuck

I make bowls by turning the top and inside first, then reversing the blank and turning the bottom. This lets me use a standard faceplate for the heavy roughing-out and hollowing operations. For the second step, I switch to a special chuck to finish the bottom. The shopmade chuck described here does a good job—four dowels grip the bowl's rim and provide adjust-

ment for centering. To make the chuck, mount a $\frac{3}{4}$ -in. thick, 12-in. dia. disc to a faceplate, true it and mark the center. Remove the disc and screw four 1-in. thick, 2-in. wide segments to the rim 90° apart. Return the disc to the lathe and true the segments into semicircular arcs $1\frac{1}{2}$ in. wide. Remove the disc again and mark the centerline of each segment radially for installing a threaded insert. Counterbore each segment from the inside (remove if necessary) to accept a $\frac{3}{8}$ -in. or $\frac{1}{2}$ -in. dowel pin. Screw hex-head setscrews in the threaded inserts to tighten the dowels against the bowl rim.

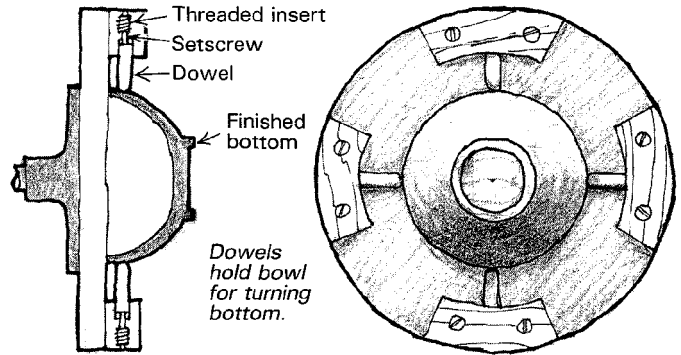

To use the chuck, first mount the bowl on a faceplate, and turn and sand the top and inside. While the bowl is still on the faceplate, mark the center of the bottom with a pointed steel rod through the back of the faceplate.

Remove the bowl from the faceplate and mount it in the special chuck. To center the bowl, bring up the tailstock and use the point on the dead-center as a reference. Tighten the work in the chuck by screwing in the setscrews in the rim, then retract the tailstock. With longer dowel pins, the chuck will hold work as small as 4 in. Of course, the chuck could be scaled down for smaller work.

For safety's sake, limit your work to the very bottom of the bowl—keep your fingers away from the exposed dowels.

—F.K. Anan, Tokyo, Japan

Plywood shelf dadoes

Here's a tip from an old patternmaker. For plywood carcasses, instead of routing dadoes for the shelves, laminate $\frac{1}{2}$ -in. and $\frac{1}{4}$ -in. plywood together, leaving spaces between the $\frac{1}{4}$ -in. sheets for the shelves to be slid into place. A hardwood facing strip on the front edge will conceal this lamination joint.

—Frank L. Gallo, Ancaster, Ont.

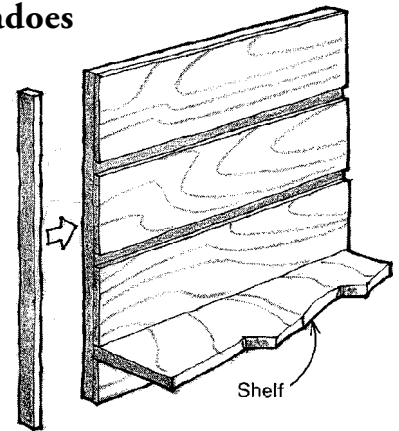

Foam faceplate for turning bowl feet

One common method of chucking a bowl blank in a lathe is to use glue and paper to attach a waste piece to the bottom of the blank, then screw the faceplate to the scrap—a time-consuming procedure. If your bowl design calls for a small foot ($1\frac{1}{2}$ -in. dia. or so), here's a faster, easier procedure.

First screw the bottom of the blank directly to a 3-in. faceplate and turn the inside to finished size. Turn the outside rim to size, but leave the bottom oversize so you won't hit the faceplate screws. Remove the blank from the faceplate and

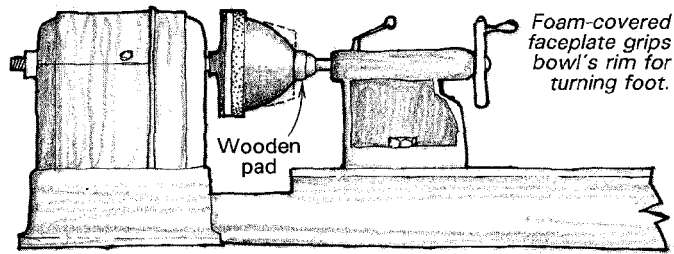

reverse it on the lathe, holding it in place between a foam-covered faceplate and the tailstock. Now finish the foot to final size, cutting away all traces of the screw holes.

To make the foam faceplate, glue 1-in. thick foam to a trued-up 4-in. or 5-in. maple disc screwed to a 3-in. faceplate. I use a ball-bearing tailstock center, fitted with a 1/8-in. flat wooden pad, to press the bowl into the foam disc.

—Max M. Kline, Saluda, N.C.

Reversing pipe clamps

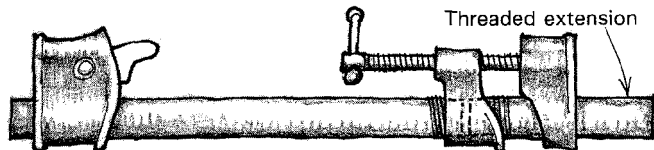

It's handy to be able to reverse a pipe clamp so it can be used to push something apart. In fact, special clamp heads are sold for this purpose. As a thrifty alternative, if you add a short section of pipe to the head as shown, you'll be able to reverse any standard pipe clamp at will.

Screw the head on backwards and stop about halfway. Now screw the short 6-in. piece into the clamp head in the normal fashion. Reverse the shoe, and you have an efficient spreading clamp. —T.D. Culver, Cleveland Heights, Ohio

Extending pipe clamps

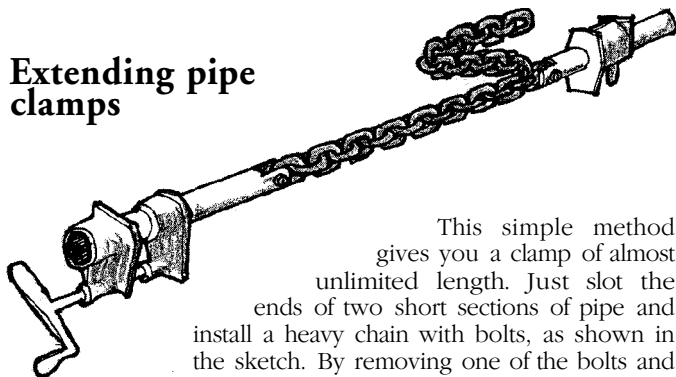

—Harold R. Olsen, Fox Island, Wash.

Quick tip: When I clamp my electric drill in a vise, I use 1-in. thick Styrofoam insulation scraps as a cushion to distribute the pressure evenly. —Dwayne J. Intveld, Hazel Green, Wis.

Regrinding chisels on a disc grinder

Here's a method that I think is unbeatable for regrinding chisels and plane irons. I clamp my Makita portable disc grinder in a Workmate vise (with a couple of pine jaws) and use a board, shimming it if necessary, to produce a surface flush with the grinding disc. Then I clamp the chisel in a

honing guide (I have a Japanese model with handles, as shown, available from Garrett Wade). The roller of the honing guide runs on the board while the blade is ground by the disc. I keep the blade from overheating by frequently dipping it in water. Since the blade remains in the guide, I can return it to the grinding disc at precisely the same angle.

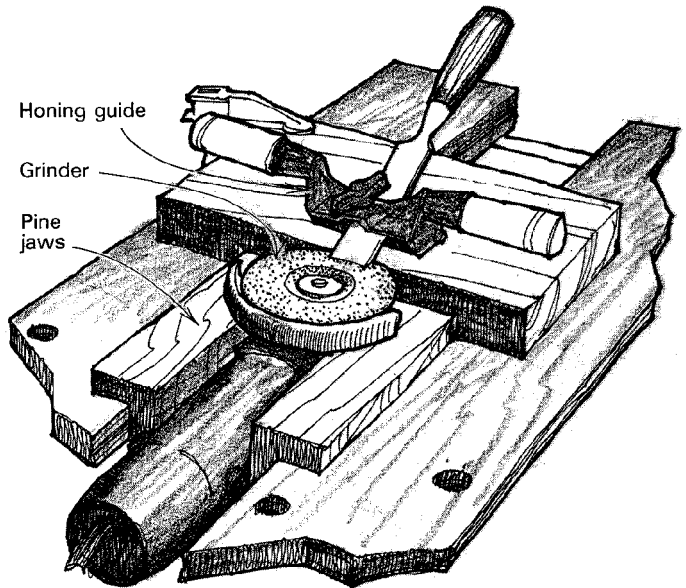

I prefer the Japanese honing guide to others because the spokeshave-like handles allow me to rock the guide slightly from side to side to produce a crowned edge on plane irons. This would be possible with other guides, but the handles on the Japanese guide provide greater control.

With this method, I have reground bevels that are indistinguishable from those ground by the factory. It has changed a frustrating and difficult task into one I can accomplish with precision and ease. —Robert B. Campenot, Freeville, N.Y.

Quick tip: My industrial arts students break scores of jigsaw blades, and in these times of tight budgets, we often use broken bandsaw blades as a substitute. I discovered that you can cut a bandsaw blade down to suitable proportions with tin snips, removing most of the metal from behind the teeth. The blade curls when you cut it, but it straightens out again under tension. —John Batten, Enosburg Falls, Vt.

Homemade bit for deep holes

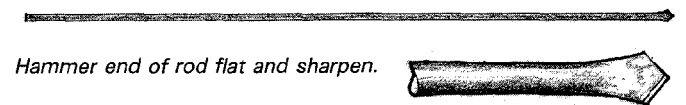

To drill holes for long threaded rods, I hammered one end of a 26-in. steel rod flat and sharpened it as shown in the sketch. The bit won't pull chips out of the hole like an expensive ships' auger, so you'll have to retract it more often to clear the chips. Considering the savings, this is a minor inconvenience.

—Ralph Zwiesler, Freesoil, Mich.

Methods of Work buys readers' tips, jigs and tricks. Send details, sketches (we'll redraw them) and photos to Methods, Fine Woodworking, Box 355, Newtown, Conn. 06470. We can acknowledge contributions only when the final decision has been made. We'll return those that include an SASE.

Slot mortiser

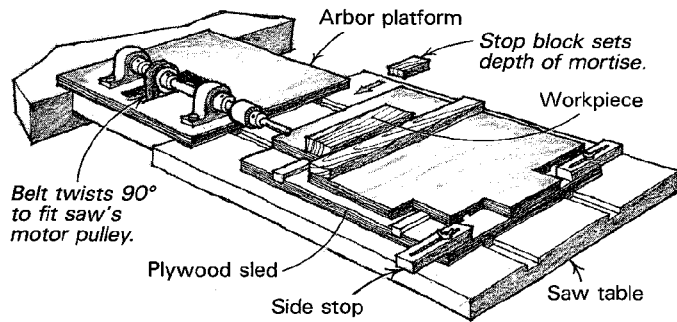

This low-cost slot mortiser utilizes my Sears saw table and motor. The arbor platform sits snugly in a space between the saw table and a catching table I built behind the saw. Short rails under the platform fit the miter-gauge slots to keep the platform from shifting. The V-belt on the arbor twists 90° and slips over the saw's motor pulley (the direction of twist determines which way the arbor will turn), and then the weight of the motor keeps the belt taut.

The sliding table consists of two plywood sleds that allow forward-and-back and side-to-side motion. Hardwood runners are attached to the lower sled, top and bottom. The top sled has two sets of grooves, so it can be repositioned atop the lower sled for end-grain mortising, at 90° from the position shown in the sketch. Various stop blocks limit the mortiser's travel and control mortise depth. To adjust for mortising stock of various thicknesses, shim the work or the arbor platform.

—Joel Katzowitz, Marietta, Ga.

Stationary jig for cutting open mortises

The jig shown below is used to cut open bridle-joint mortises in frame members. It solves many of the problems inherent with sliding jigs, which tend to be complicated to make and adjust, and sometimes wobble during the cut. The only disadvantage is that the jig leaves a slight concavity at the bottom of the mortise, as shown in the sketch. This space doesn't show in the finished joint, however, and since its end grain, the missing wood isn't critical to joint strength.

Make the jig by screwing a hardwood fence to an 8-in. wide piece of 3/4-in. plywood. Clamp the jig to the rip fence so that the frame member to be mortised will be centered over the saw arbor. Adjust the rip fence so that the sawblade is the proper cheek thickness from the jig.

To cut the mortise, hold the workpiece firmly against the plywood, with its back edge tight to the hardwood fence. Plunge the work down the fence onto the blade. Draw it up, flip it and cut the other cheek. On narrow stock, this will complete the mortise. For wider stock, chisel out the waste.

—Frederick J. Miller, Chatsworth, Ont.

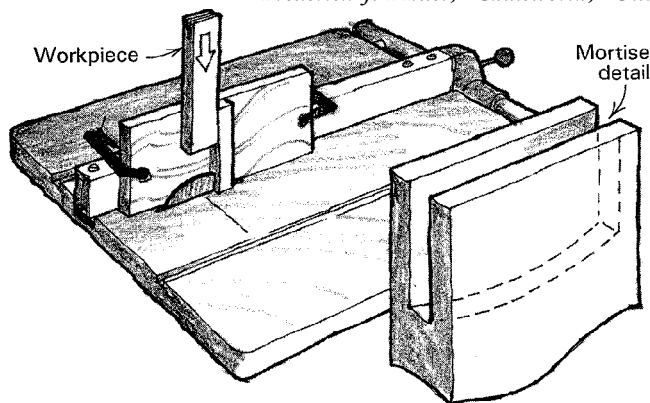

Simple saw vise

Sometimes, far from home, your handsaw suddenly encounters a hidden nail. Do you haul the saw back to your shop to resharpen, or do you apply an extra few pounds of elbow grease? Neither solution is very satisfactory. Instead, why not fashion a simple saw vise from a few scraps and resharpen your saw right on the job? All you need are three pieces of 2x4 and a couple of lengths of hardwood 1x2s. There are no critical dimensions, so just use what you have.

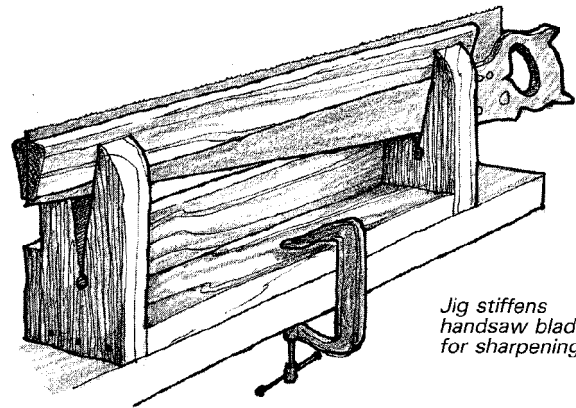

For most handsaws, an 18-in. long jig is about right. The height of the uprights depends on where you plan to set up the jig; I aim for the sawteeth to be at elbow height for comfortable sharpening. Cut long, matching V-notches in the top of each upright, as shown in the sketch, and drill a hole at the point of the V to reduce the chance of splitting.

Now bevel two 22-in. hardwood 1x2s so that, sandwiched together, they match the angle of the V-notch.

To use the jig, hold the wedge strips on either side of the blade about 1/2 in. down from the teeth, and tap the blade and strips down into the notches. A tap from below will release the whole thing.

—Jim Koch, Stamford, Conn.

Foam finish applicators

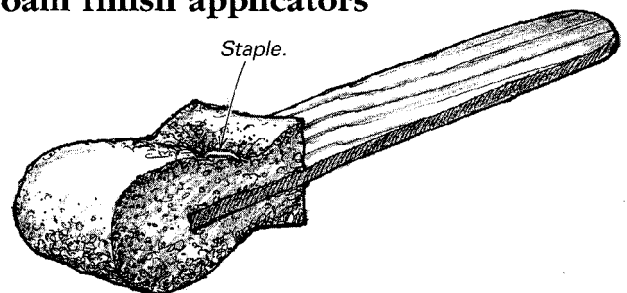

You can easily make throwaway finish applicators from urethane foam, which is commonly sold in fabric and upholstery shops. Cut the foam to a 1x1x2 size, split it down the middle and staple it to a scrap of thin wood for a handle. You can then trim the free end with scissors to suit the job.

—David E. Price, Baltimore, Md.

Quick tip: To keep glue from sticking to forms and jigs, we use a car wax such as Du Pont Rain Dance or Treewax Four Seasons. Car wax doesn't seem to penetrate and discolor the work the way softer waxes do. Of course, seal the form first with lacquer or shellac. —Peterman Lumber, Montana, Calif.

Clamping hexagonal box tops

I enjoy making small hexagonal boxes because they are a greater challenge to construct and are more visually interesting than square boxes. Gluing up six pieces for the tops, however,

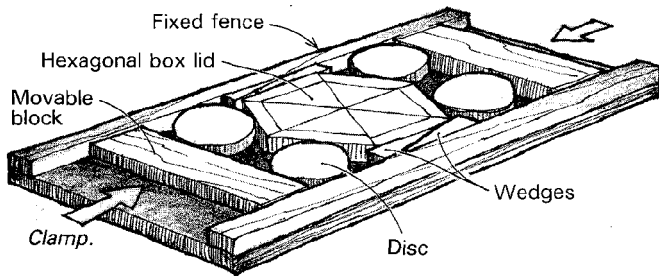

presents a problem. The jig pictured here solves things by securely holding all the pieces with one bar clamp.

The jig consists of a plywood tray with two parallel fences fastened to the long edges. The operating width of the tray is adjusted by means of two pairs of wedges, as shown. The bar clamp spans the two clamping blocks, and four wooden discs redirect the pressure at the proper angles.

—Steven Barnhill, Gunnison, Colo.

Drawing giant, shallow arcs

Drawing a large-radius arc through three points isn't easy if you don't have room to use a rope as a compass. Here's a method I worked out while arranging some permanent chairs.

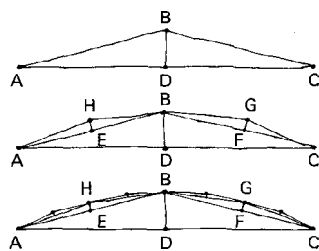

If A, B and C are points on the circle, first connect these points and drop a perpendicular from B. At the midpoints of AB and BC draw two perpendicular lines and measure along them a quarter of the distance BD. Repeat the operation with the new outside lines, this time measuring a quarter of the distance FG.

Continue the process until you have a close approximation of the true arc. It will be surprisingly accurate—especially if the arc is only a small portion of the circumference (i.e., BD is small compared to AC).

—Christopher Yonge, Lothian, U.K.

Quick tip: Stain will collect in sanding scratches that have been overlooked, darkening them more than the surrounding wood. If you wipe the wood with mineral spirits first, it will show up the scratches long enough for you to resand. Even if there are no scratches, wetting and wiping is a good way to remove sawdust (which is what I was doing when I discovered this trick).

—G Theodore Odom, Angleton, Tex.

Tablesaw guard

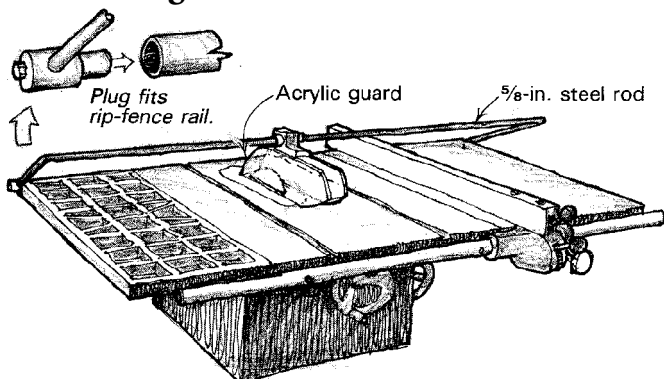

Unlike most other tablesaw-blade guards, which after a couple of frustrating experiences are left hanging on the wall, this guard is quite usable. The guard's main advantage is that it

remains in place for most operations, including dado and molding cuts. If it's not needed for an operation, the guard swings out of the way in seconds, or can easily be removed completely from the saw. The inexpensive guard also acts as a hold-down—a safety bonus.

Make the guard shield from $\frac{1}{4}$ -in. thick clear acrylic. The guard frame is a length of $\frac{3}{8}$ -in. cold-rolled steel bent into a U shape. Turn two metal or wooden plugs and attach them to the arms of the frame as shown in the sketch. The plugs should be sized to pivot easily in the holes in the ends of the back rip-fence rail. The frame fits on the saw by springing slightly so that the plugs snap into the holes.

—K.L. Stewart, Ladysmith, B.C.

Bench vise improved

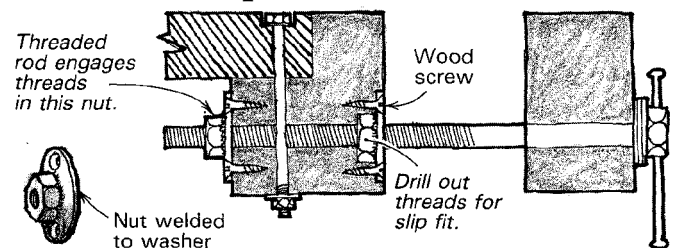

Joe Laverti's homemade bench vise (*FWW* #37, p. 24) is a fine idea. But because the heavy steel screws project from the bench, the vise is a potential leg-bruiser. From my school days, I remember a shop teacher hurrying down the aisle between the benches and smacking his leg into an open vise. He was badly injured and the memory has never left me. With a couple of modifications, as shown in the sketch, Laverti's vise can close up like a regular vise and thus be safer.

My vise uses two threaded rods. At the front end of these, I welded a nut and drilled through it to install peened-over bars for handles.

—Al Glantz, Winthrop, Wash.

Quick tip: When I use a plug cutter in an electric drill, I have a simple jig that prevents the cutter from walking around on the stock. I drill some cutter-size holes in a piece of scrap, then clamp it to the stock. The jig also serves to start the cutter right on target.

—James L. Wheeler, Houston, Tex.

Aquarium pump clears sawdust

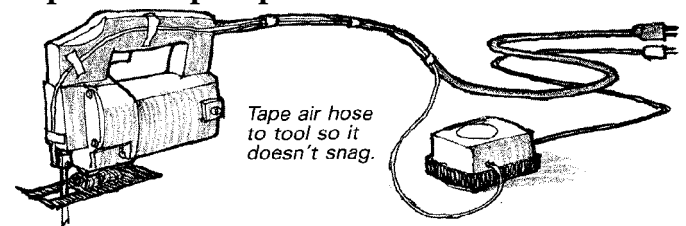

Small diaphragm-type aquarium air pumps will supply a jet of air to keep sawdust away from pattern lines when scroll-sawing and the like. Fit the pump with a length of plastic tubing and tape the tube in place on the tool, aimed so it blows away the dust. The small pumps, which cost less than a good router bit, can be purchased at any aquarium supply store. Heavier pumps are also available and would serve with larger tools.

—Michael H. Marcus, Portland, Ore.

Double scratch stock

A scratch stock is a simple but effective tool for cutting molding patterns on odd-shaped workpieces. But when you scrape against the grain, as is often necessary on curved members such as tripod table feet, the tool chatters and can leave a

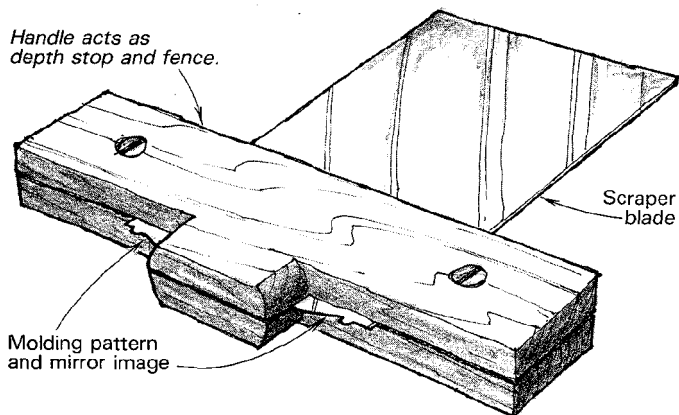

rough surface. This double scratch stock solves the problem.

Grind or file mirror images of the desired pattern on a cabinet scraper, as shown. File the edge to 45°, turn the burr, then fix the blade in a hardwood block that will act as depth stop and fence. Adjust the scraper blade for the proper depth of cut and tighten the screws to lock the blade in place. When you run into contrary grain, simply switch to the other side.

—John S. Pratt, Avondale Estates, Ga.

Quick tip: I sharpen my turning tools on aluminum oxide sandpaper, glued to the face of a 10-in. aluminum disc mounted outboard on my lathe. It's only a step away when I want to touch up a tool. Each sheet of sandpaper lasts a couple of weeks, and it gives me a flat bevel, which I prefer to a concave one.

—A.R. Hundt, Tasmania, Australia

PEG vat from scavenged water heater

To make an inexpensive heated unit for impregnating green wood with PEG, I went to a nearby plumbing supplier and scavenged an old electric water heater from their "boneyard." I removed the outer shell and cut the top off the tank, leaving an open, 20-in. deep tank. I placed a metal rack in the tank to support the PEG pail and protect the heating element. I enclosed the heater in an insulated plywood box fitted with large casters.

To use the vat, I place a heavy-duty, PEG-filled rubber garbage pail in the tank, fill the tank with water (like a double boiler) and turn on the thermostat. The heater works great, and my only expense was the garbage pail.

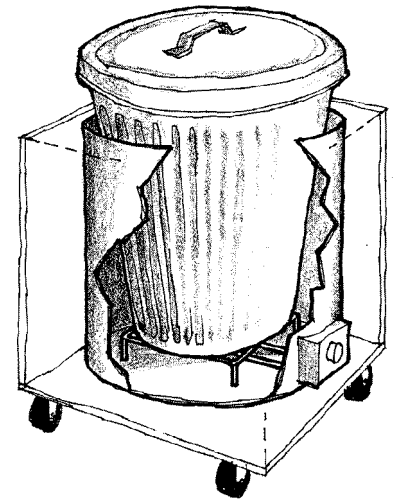

—Mark Pleune, Suttons Bay, Mich.

Methods of Work buys readers' tips, jigs and tricks. Send details, sketches (we'll redraw them) and photos to Methods, Fine Woodworking, Box 355, Newtown, Conn. 06470. We can acknowledge contributions only when the final decision has been made. We'll return those that include an SASE.

Chucking bowl blanks

It seems to me, in reading past methods on woodturning, that many turners must be spending more time fiddling with faceplates and attaching the work to the lathe than actually turning. I'd rather spend my time turning, so I devised this quick procedure that takes me from a blank to a finished 10-in. dia. bowl with 1/8-in. thick walls in 30 minutes.

The key to the method is a 6-in.-I Universal Chuck, which has an expanding collet that locks into a dovetail recess in the workpiece. First I cut a recess in the top of the blank, using a router with a dovetail bit and the circular template shown in the sketch. The router rides around inside the shoulder on the template to produce a recess to fit the chuck.

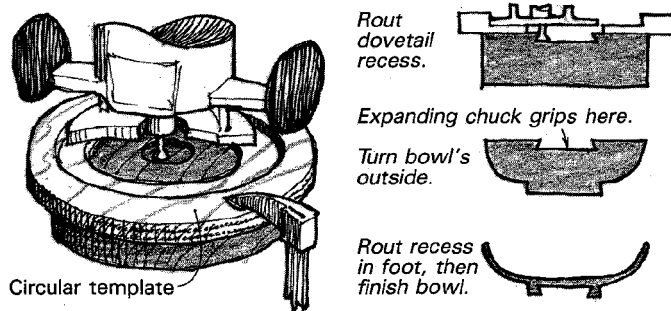

With the circular blank mounted on the chuck, I turn the bowl's outside profile. At this point you can turn a chuck recess in the bottom of the bowl if you choose, but I find it easier and faster to remove the bowl and cut the new recess with the router. It's important to center the bowl's foot in the template before cutting the recess, otherwise the bowl will wobble on the lathe. If you turn the foot to fit the center hole in the template, this won't be a problem.

Now I return the bowl to the lathe and complete the inside. If desired, you can part off the bowl above the foot to eliminate all signs of the attachment method.

—F.H. Crews, High Point, N.C.

Quick tip: I steambend short pieces of wood by wrapping them in a damp towel and cooking them in a microwave oven. Three minutes on "high" will make a slender chair spindle limber enough. For heavier pieces, resoak the towel from time to time.

—Robert Hanlon, Gloucester, Mass.

Folding saw rack

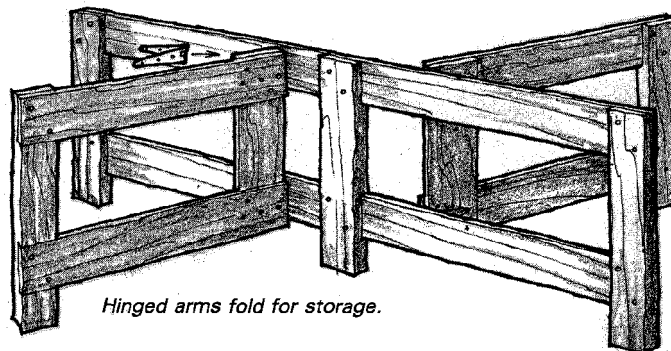

This multipurpose folding rack takes the place of several sawhorses, yet when stored it occupies less space than one. Unfolded, it can support a 4x8 sheet of plywood for ripping or crosscutting. It's also handy for cutting 2x4s to length and other framing work. With a piece of plywood on top, it becomes a handy work platform.

—Phil Mackie, Rhinelander, Wis.

Sandpaper tearing tool

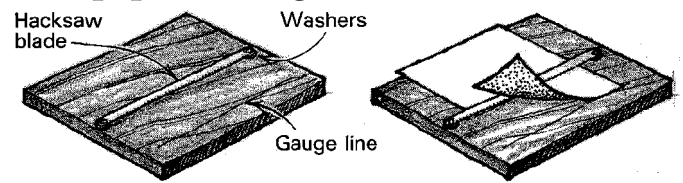

This idea has been around for a while, but this tool is one of the best I know of for cutting sandpaper sheets. Simply screw an old hacksaw blade to a scrap of plywood with washers under the blade for spacers. Mark standard sheet sizes on the plywood, or attach a rule for measuring sheets. To use, simply slide a sheet of sandpaper under the blade and pull for a quick, neat cut.

—Rick Mattos, Vallejo, Calif.

Quick tip: To tilt a tablesaw blade accurately, even to half a degree, attach a Sears magnetic-base protractor (#9-3995) directly to the blade.

—William Forsythe, Dansville, N. Y.

Precise tablesaw jointer disc

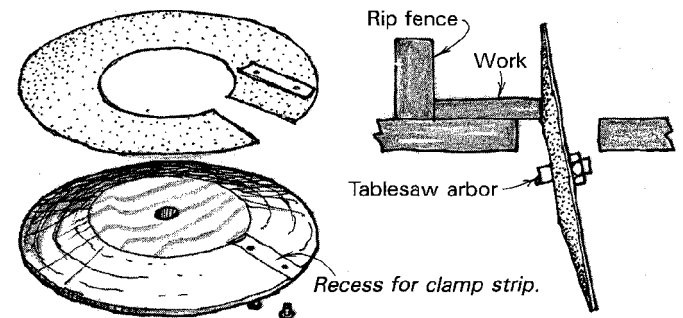

This cone-shaped tablesaw jointing device does precise work both in sanding boards to width and in leaving a good gluing surface. It's basically a 10-in. conical disc made from 3/4-in. plywood. What makes the device special is the small cone angle (9° on mine). Unlike a flat disc, which contacts the workpiece across its full width, the cone's contact is restricted to a small area, the radius that's located directly above the arbor. Another benefit is that vertical adjustments of the saw arbor produce very small increments in cutting depth (as an industrial modelmaker, I sometimes have to work in thousandths of an inch).

I fiberglassed the back of my disc for extra strength, and it's served me well for years. The cutting surface is an abrasive sander disc cut to fit the cone face and glued and damped in place. I use plastic-laminate glue to secure the paper; to change abrasives I dissolve the cement with acetone. Varying the grade of abrasive paper allows various compromises between a fast cutting speed and good surface quality.

To use the sander, tilt the tablesaw's arbor to present a vertical cutting surface, as shown in the sketch. I usually guide the work along the rip fence.

—Dr. Robert Bogle, La Jolla, Calif.

Quick tip: When my scroll-saw blades dull, I extend their life by clamping a 1 1/2-in. thick wooden table on top of the regular table. This moves the work up to the teeth that haven't been used yet.

—Joe Carson, New Haven, Conn.

Improved push sticks

In the past eleven years I've worked in several shops, from a furniture factory to a custom cabinet shop, and taught some high-school woodworking as well. As you might imagine, I've seen my share of tablesaw push sticks, most of which resemble

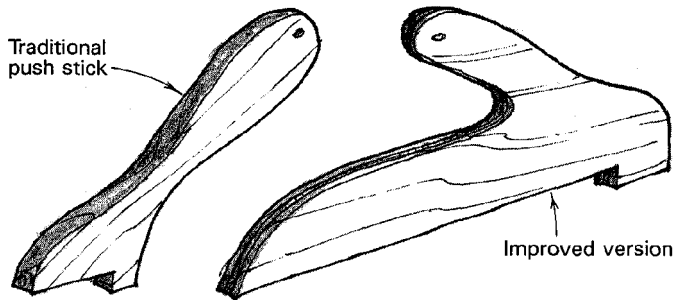

the design shown at left in the sketch. The major shortcoming of this design is that it does little to counteract the table saw's tendency to lift the work off the table.

The alternative design, shown on the right, ensures a downward thrust on the work. In production runs, this design is safer and less fatiguing because you need only push forward, rather than forward and down. You can make wide push sticks from solid wood, but for narrow ones choose plywood, otherwise the step on the bottom of the stick may split off.

—Angela Daluisio, Lancaster, N. Y.

Quick tip: I tried various safety glasses and face shields, but none kept my belt sander's dust out of my eyes, not until I donned a pair of motocross goggles. These have impact-resistant lenses, lightweight plastic frames, one-way ventilation and a detachable face mask—all for \$15 from the local motorcycle shop. Success at last!

—Tim Rott, San Jose, Calif.

Ellipse layout revisited

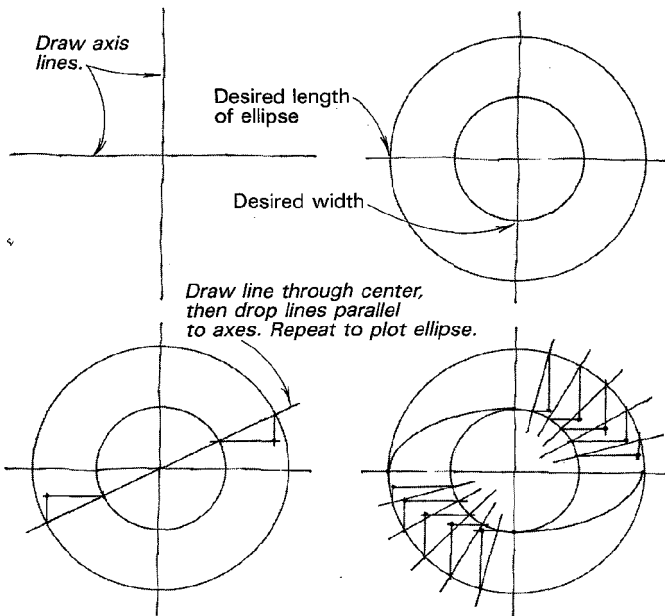

When laying out an ellipse, most people care more about its finished length and width than about the distance between the two focal points. The draftsmen's method shown in the sketch gets directly to the point without requiring calculations and gadgets.

—Lawrence Whytock, Brockville, Ont.

Quick tip: When I have a lot of power-sanding to do—either finish, belt or disc—I always wear a handball player's glove. It's ventilated on the back for comfort, and the palm is padded, which helps cushion some of the vibration. I can sand for hours without getting that "tingling" sensation in my hand and arm.

—R. Broberg, Huntington Beach, Calif.

Clamping odd shapes

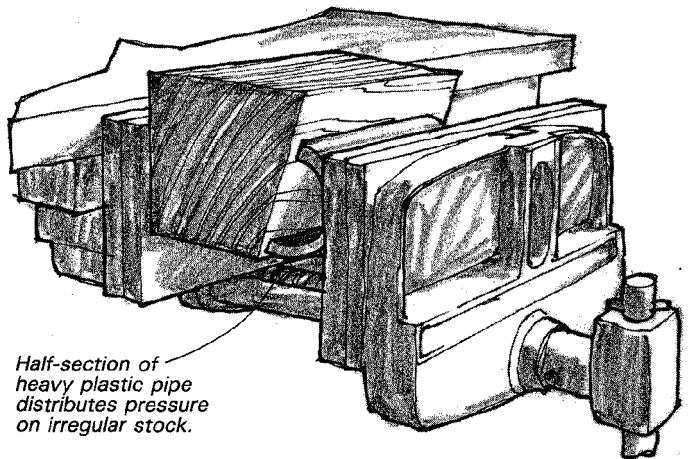

To hold odd-shaped workpieces in your bench vise, cut a section of heavy plastic or iron pipe in half and place the half-round against the workpiece. The pipe will distribute the pressure and hold the workpiece securely.

—Albert T. Pippi, Baltimore, Md.

Quick tip: A scrub plane cuts fast and dean because its iron is ground to a slight curve—the center cuts deep and the corners feather out of the wood. Instead of shelling out \$35 for a scrub plane, I just bought a replacement iron for my jack plane and ground it to a gentle curve. When the board gets down close to thickness, I switch back to my regular iron and finish up.

—Ben Barclay, Gibsons Landing, B. C.

Alignment block for accurate threading

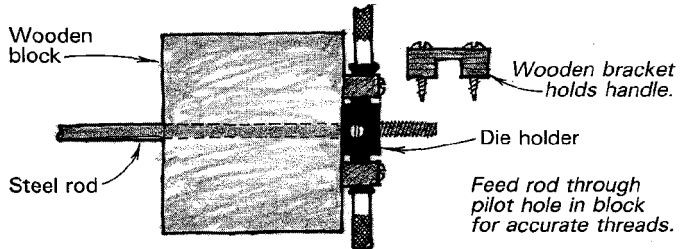

I wanted to make my own maple handscrews, but found that freehand threading of the 3/16-in. steel rods invariably resulted in erratic thread patterns and wobbly clamps. I solved the problem by drilling a pilot hole through a 2-in. block and fastening my die holder directly over the hole with little maple brackets. To ensure firm damping pressure, the cutouts in the brackets should be a fraction shallower than the height of the handles. I now get perfect threads every time, both right-hand and left-hand, and have produced a number of beautifully functional clamps at a fraction of store-bought prices.

—Chris Clark, Winnipeg, Man.

Quick tip: Magnetic bars are dandy tool holders, but they aren't cheap. Here's how I double their capacity: I mount the bar out from the wall on 1/2-in. spacer blocks and stick my infrequently used tools to the rear surface, handles up. My everyday tools go on the front, handles down. It's like getting a 50% discount.

—Doug Hammer, Solon Springs, Wis.

Clothes-iron shop applications

An ordinary clothes iron can simplify two furniture repairs: raising dents and reattaching loose veneer. To use the iron to remove dents and dings, set the heat to "cotton" or "wool,"

wet a cotton doth pad and place it over the dent. Press the iron to the pad for two or three seconds and check your progress. Repeat the procedure until the dent is flush.

To repair loose veneer, place a damp doth between the iron and the work. Apply the iron to the spot, taking care to move it about so as not build up the heat too fast—the veneer will scorch if you're not careful. This method doesn't work with some adhesives, but most old furniture was veneered with hide glue, which will reactivate and hold the loose veneer down again.

—Rollie Johnson, Sauk Rapids, Minn.

Quick tip: My shop iron steams out a dent only once in a while, but it does daily work keeping my coffee warm. The iron lives hot-side-up in a wall bracket that's bandsawn to hold it securely.

—Robert H. Hoelzer, Seattle, Wash.

Safe molding on the tablesaw

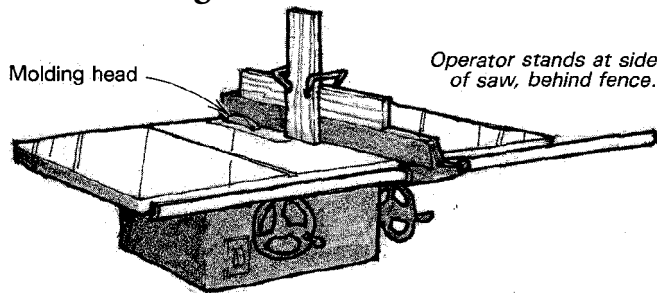

After I had a \$1300 accident at my jointer last year, I have a renewed interest in safety. The scariest operation I know is using the molding head on the tablesaw to shape short vertical boards such as drawer fronts. I have rendered this operation relatively harmless by damping the drawer front to a long board that rides the top of the rip fence. I guide the work through the blade, standing to one side of the saw behind the rip fence.

—Richard Tolzman, Excelsior, Minn.

Quick tip: Anyone who restores furniture knows how difficult it is to match the original wood, stain, leather and so on in damaged pieces. To make life easier for the restorers who follow me, I always include samples of such things somewhere in each piece I build. Sometimes I make a drawer a little short to allow room for a package clearly labeled "parts," or I attach the package to the bottom of the carcass. Stain for touch-ups goes in a corked test tube, doubly protected with sealing wax. I also identify the finish and include any other pertinent information.

—Pendleton Tompkins, San Mateo, Calif.

Routing V-grooves in tongue-and-groove

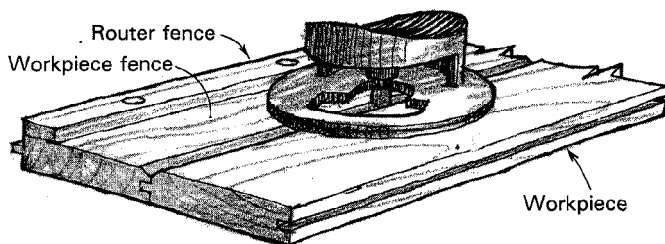

To produce identical chamfers on matching edges of tongue-and-groove stock, I use an extra piece of stock with a nailed-on router fence, as shown in the sketch. Both the tongued and the grooved edges can be pushed flush to the jig, ensuring a balanced V-groove in the finished work and eliminating the extra setup that would be required with a shaper or a table-saw. You could adapt the idea to a router table just as easily.

—W.A. Ward, Underbill, Vt.

Extending lathe capacity

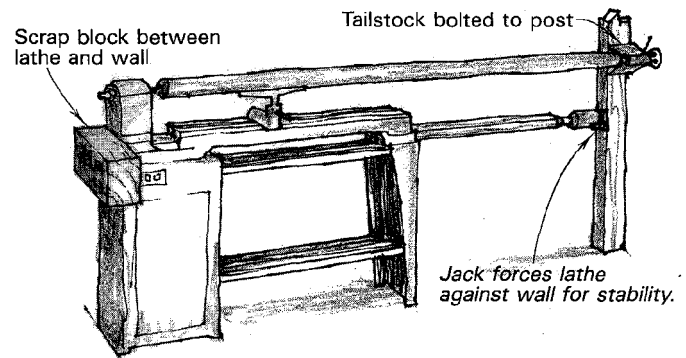

Here's how I extended the bed capacity of my lathe. First I bolted the tailstock to a support post in my shop. To make sure the tailstock was level with and in line with the headstock, I ran a chalkline and a line level between the two. To keep the lathe in position, I used a hydraulic cylinder to force the lathe's base against the wall—a spare Lally column would work nearly as well. A piece of scrapwood protects the lathe where it presses against the wall.

For slightly shorter stock, you could shim the lathe out farther from the wall, or dispense with the jack by bolting the lathe to the floor where you need it. I did half the turning and then flipped the workpiece to finish, so I could use my regular tool rest. If you have a freestanding tool rest, you can do the work all in one shot.

—D. Mayerson, Berkeley, Calif.

Quick tip: When laying out $\frac{1}{4}$ -in. holes for shelf supports on cabinet sides, cut a strip of $\frac{1}{4}$ -in. pegboard and use the holes as a drill guide.

—Richard Tolzman, Excelsior, Minn.

Edging plywood drawer fronts

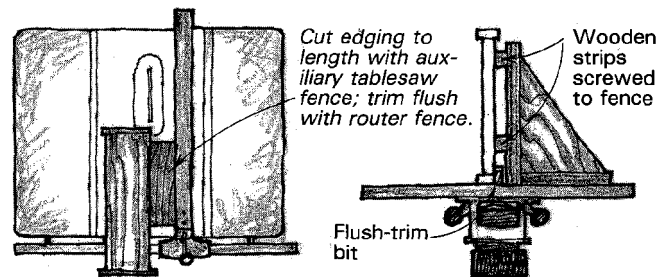

Here are a couple of tricks I use to apply solid-wood edging to plywood drawer fronts. The first is a simple auxiliary tablesaw fence to trim the edging to length. I glue the edging to the ends of the drawer, leaving a $\frac{1}{4}$ -in. overhang. Then, with the auxiliary fence adjusted for a perfect flush cut, I simply push each corner through the saw.

To trim the edging flush with the face of the drawer front, I use the router table setup shown in the sketch. Make a tall fence for the router table and screw a couple of wooden strips to it. Chuck a ball-bearing flush-trim bit in the router and adjust the fence so the bearing is flush with the surface of the strips. When you run the panels through, the edging rides under the bottom strip and the tall fence makes it easy to keep the panel perpendicular.

—Rick Turner, Petaluma, Calif.

Methods of Work buys readers' tips, jigs and tricks. Send details, sketches (we'll redraw them) and photos to Methods, Fine Woodworking, Box 355, Newtown, Conn. 06470. We can acknowledge contributions only when the final decision has been made. We'll return those that include an SASE.

Jointer thickening—another design

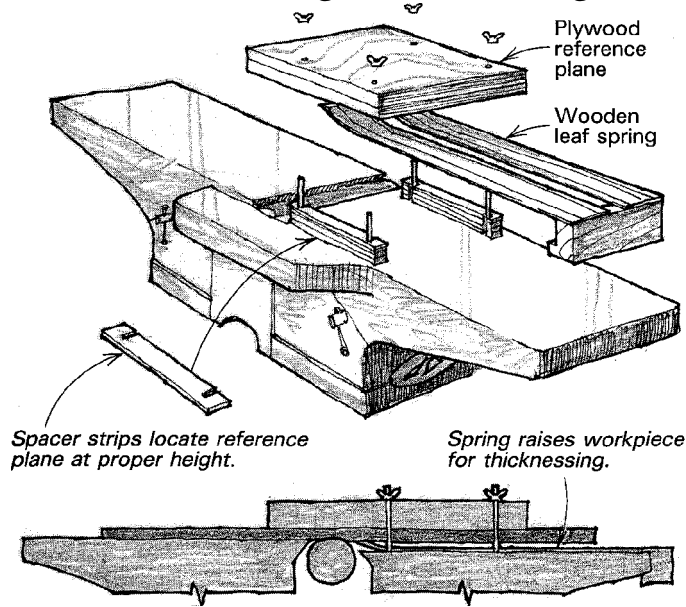

The design presented here converts a jointer to a true thickness planer, and it takes just a couple of minutes to make the conversion. On a regular thickness planer, the work is fed between the cutterhead and a flat bed. My method's principle, if you imagine a regular planer turned upside down, is the same: the workpiece is raised by wooden springs and pressed against a rigid overhead reference plane above the cutterhead.

My reference plane is laminated from two pieces of $\frac{3}{4}$ -in., 9-ply birch plywood. It is held above the cutterhead by an assembly of aluminum spacers, threaded rods tapped into the feed table, and wing nuts. Another necessary component is a flat leaf spring, which presses the workpiece against the reference plane until it begins to ride the outfeed table. I made the spring from two $2\frac{1}{2}$ -in. wide, $\frac{1}{8}$ -in. thick strips of oak by steam-bending the last 4 in. of the strips. A simple cleat that hooks onto the end of the jointer table holds the spring in place.

The dimensions of the reference plane are not critical—an 8-in. square is about right for a 6-in. jointer. Wax the underside of the plane to reduce friction. I made the spacer strips by epoxying layers of $\frac{1}{8}$ -in. thick aluminum strips together to form pairs of $\frac{1}{4}$ -in., $\frac{1}{2}$ -in., $\frac{3}{4}$ -in. and $\frac{1}{8}$ -in. spacers. The spacers are notched so they can slip onto the threaded rods—with the reference plane in place.

To use, joint one face of all the pieces you are going to plane. Select spacers equal to the thickest piece plus another $\frac{1}{4}$ in. for the spring. Bolt the assembly in place, position the spring, and back the infeed table down until the thickest piece starts to cut. Plane all the pieces at this setting before lowering the infeed table for the next cut. Continue until the final thickness is reached.

—J.E. Keister, Cincinnati, Ohio

Collet chuck for turning miniatures

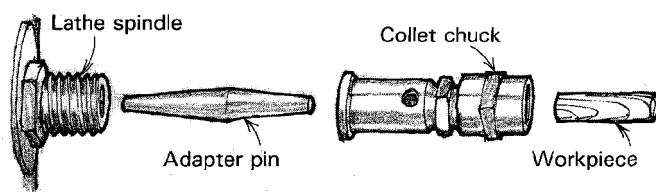

This collet chuck, adapted from a drill-press attachment, is inexpensive but effective for turning miniatures on the lathe. To make the chuck, purchase a drill-press attachment called a col-

let chuck with heavy collar (Sears part No. 9-24672). The holding collar that fastens the device to the drill press is not needed on the lathe. You'll also need an adapter pin with a male No. 33 Jacobs taper on one end and a Morse taper on the other end to fit your lathe spindle.

Fit the chuck to the lathe, then tighten the collet on a short length of $\frac{1}{2}$ -in. dowel, and you're ready to turn. A set of bushings that comes with the chuck will let you turn $\frac{1}{4}$ -in. and $\frac{3}{8}$ -in. dowels in addition to the nominal $\frac{1}{2}$ -in.

—R.E. Hollenbach, Livermore, Calif.

Quick tip: I prevent joints from sliding around during glue-up by driving two $\frac{1}{2}$ -in. brads halfway into one inside face of the joint, then clipping off the heads so about $\frac{1}{32}$ in. protrudes. When the joint is assembled for clamping, the two little spikes bite and hold firm.

—David G. Mensing, Tucson, Ariz.

All-wood adjustable shelf bracket

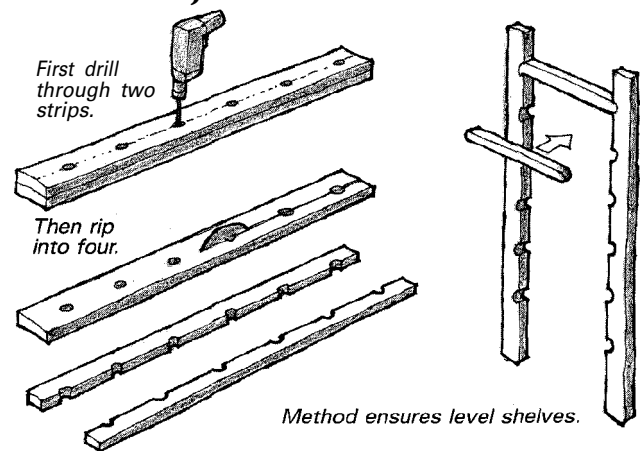

This easy-to-make shelf bracket ensures accuracy because both pairs of shelf-height notches are established with one hole. To make the bracket, clamp two 1x2 strips together and drill a series of holes down the centerline through both strips. The holes will set the spacing between shelf locations. Now rip each 1x2 on its centerline to produce two matching brackets for each end of the shelf unit. Install the brackets in the carcass and cut several $\frac{3}{4}$ -in. square shelf supports to fit in the notches. Round the ends of the shelf supports to match the half-round notches in the brackets.

—Rollie Johnson, Sauk Rapids, Minn.

Clamping round tabletops revisited

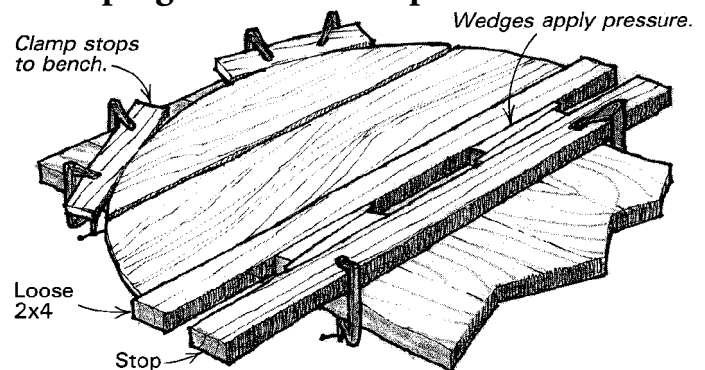

Here's an alternative to Jim Small's clamp-perch idea (FWW#47) for gluing circular tabletops. First place the tabletop on the bench and clamp three stops as shown in the sketch. Place a free-floating 2x4 against the workpiece and drive paired wedges between the clamped and floating 2x4s to apply pres-

sure to the glue joint. Here are some additional tips: Place newspaper on the bench to catch the glue that will squeeze out, and dowel the edge joint to keep the pieces from shifting. It's best to raise the tabletop up with a few thin scraps of wood—this centers the clamping pressure and allows glue to drip out without smearing. I put weights on top of the work if necessary to keep it flat while the glue sets. And as with any glue-up, it's a good idea to make a dry run first.

—Ken Jones, Lisle, Ill.

Patching veneer

This veneer-patching technique is not only easier than the "cut and fit" approach, it also results in a virtually invisible repair if the color and grain of the patch is matched carefully to the original veneer. First feather the edges of the missing veneer defect so that they taper, as shown at right. Select a piece of veneer for the patch slightly larger than the defect area and glue it into the recess. Then just scrape and sand the raised edges of the patch flush with the surrounding surface.

—Rollie Johnson,
Sank Rapids, Minn.

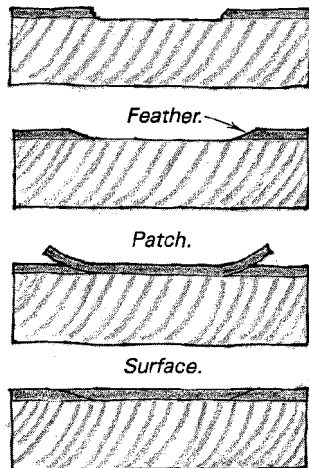

Quick tip: To maintain cast-iron machine tables, clean the table, then apply ground talc (Johnson's baby powder) with a felt blackboard eraser. The talc will fill the pores in the cast iron, providing a moisture barrier and a lubricant. Apply the talc twice a week for a couple of months, then about once a month thereafter.

—William D. Turner, Brookfield, Wis.

Center finder from a corn-chip can

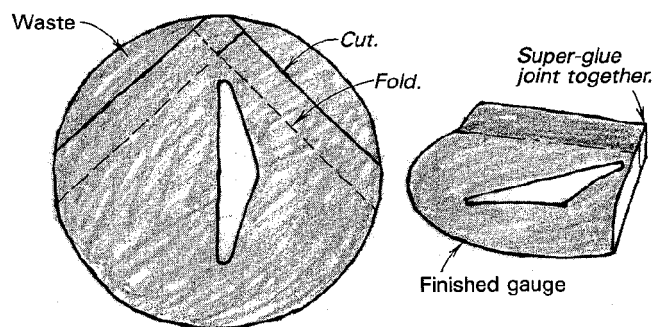

This simple, handy tool for spindle turners pinpoints the headstock and tailstock centers on round, square or octagonal blanks. To make the gauge, first tear off the circular aluminum top from a 15-oz. can of corn chips or other snack food. The thin aluminum disc is the right size and can be cut with scissors or, if backed up with a hardwood block, by a sharp wood chisel. Scribe, cut and bend the disc as shown in the sketch to produce an L-shaped lip and a diagonal marking opening. To ensure an accurate center, mark at least four diagonals on the end of the spindle and pick the point where the most lines cross.

—Eliot Birnbaum, Syracuse, N.Y.

Quick tip: To remove sanding discs applied with gummy adhesive, heat the back of the plate with a propane torch until it gets warm (but not hot), then simply ease the disc off with a dull chisel.

—George Kasdorf, Ft. Wayne, Ind.

Sharpening skew chisels

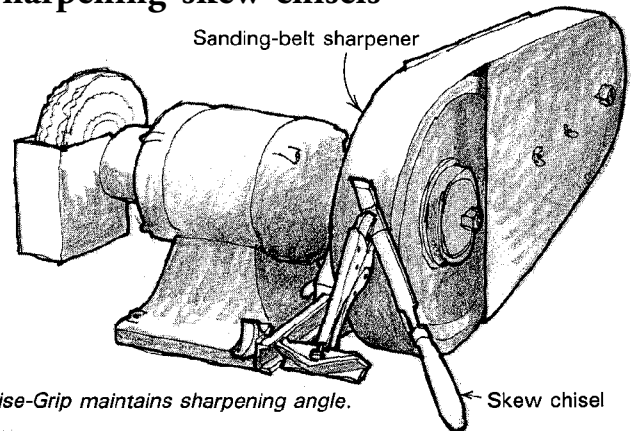

Some sharpening setups have a special tool rest to support the butt of the tool's handle, which keeps the cutting edge at the proper sharpening angle. The idea works great for straight plane irons and chisels, but presents problems for skewed tools. To put the skewed tool at the proper angle on the sharpening belt, the handle must be pulled to the side and held in midair, unsupported.

To solve the problem, I clamp a pair of Vise-Grips to the tool as shown in the sketch. I protect the chisel blade with a wrap of duct tape. If I have to disconnect the Vise-Grips during the grinding process, the imprint on the tape allows me to place the grips in the exact position again to complete the job.

—Norman Vandal, Roxbury, Vt.

Quick tip: When I'm driving wood screws, I put a drop of linseed oil in the pilot hole. It makes the screw go in with one-quarter the driving torque, allows easy assembly/disassembly during the course of the project, and offers some adhesiveness when it finally dries, unlike paraffin-covered screws. It also helps prevent rust (important in the humid Mississippi valley where I live).

—Robert E. Schuster, Geneseo, Ill.

Chisel sheaths from old glove fingers

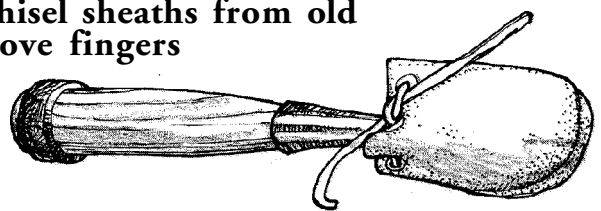

To prevent my chisels, knives and auger bits from damaging each other, I use the thumbs and fingers cut from old pairs of leather work gloves. I punch holes around the opening, and then add eyelets and a length of leather thong to tie the protector on the tool. I'm told that some leathers contain acids that encourage rust, so check your tools once in a while if you plan to try this method for long-term storage. With my everyday tools I've had no problems.

—Craig S. Walters, Forest Ranch, Calif.

Quick tip: I save my wife's old pantyhose for paint straining, and have found another use, too: I stretch a leg over the paper filter on my shop vacuum. This keeps a lot of the shavings and larger stuff from coating the paper. The filter cleans easier and lasts longer.

—C.S. Manning, Port Townsend, Wash.

Smoothing turned goods with cloth

Years ago I watched craftsmen at a Virginia shop put the final finish on lathe turnings by holding a piece of cloth against the work after sanding. Later I read that textile companies have

started using ceramic yarn guides because synthetic yarns are abrasive and cut into steel guides quickly. Putting the two observations together, I tried finishing turned chair parts by first sanding with 000 garnet paper, then holding a scrap of synthetic-fiber drapery material against the spinning work. The cloth picked up grit left on the wood, and in less than a minute did indeed give the pieces a smoother look and feel.

—Carlyle Lynch, Broadway, Va.

Disassembling old tabletops

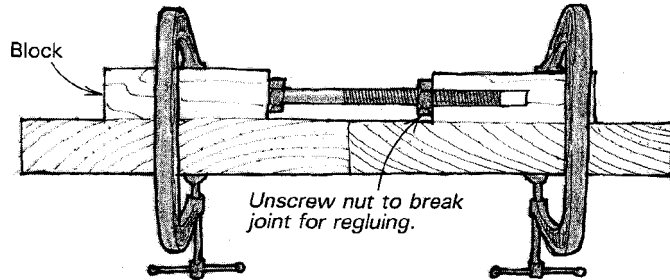

This technique is quite effective for disassembling old tabletops for regluing. It requires two scraps of hardwood, one of which is drilled to accept a hex-head machine bolt and nut, as shown in the sketch. When you unscrew the nut, it exerts pressure against the clamped blocks, forcing them, and the glue joint, apart. As pressure builds, place a piece of scrap over the joint and hammer the scrap to jolt the glue joint. This technique puts tremendous declamping pressure in just the right spot without damage to the tabletop.

—Frank D. Hart, Plainfield, Ind.

Jigsaw blower from recycled hair dryer

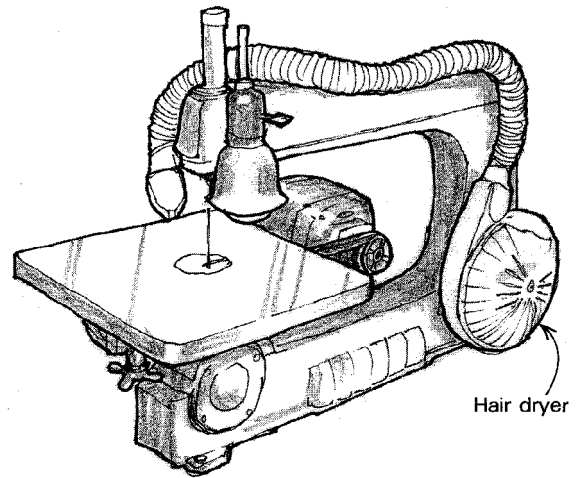

This sawdust blower is simply an old hair dryer, with its heating element disconnected, and a length of plastic hose. Wire the switch so it turns on with the saw. This system works fine—much better, in fact, than the blower that came with the jigsaw.

—Dud Brown, Birmingham, Mich.

Methods of Work buys readers' tips, jigs and tricks. Send details, sketches (we'll redraw them) and photos to *Methods*, Fine Woodworking, Box 355, Newtown, Conn. 06470. We can acknowledge contributions only when the final decision has been made. We'll return those that include an SASE.

Measuring stop block for power miter box

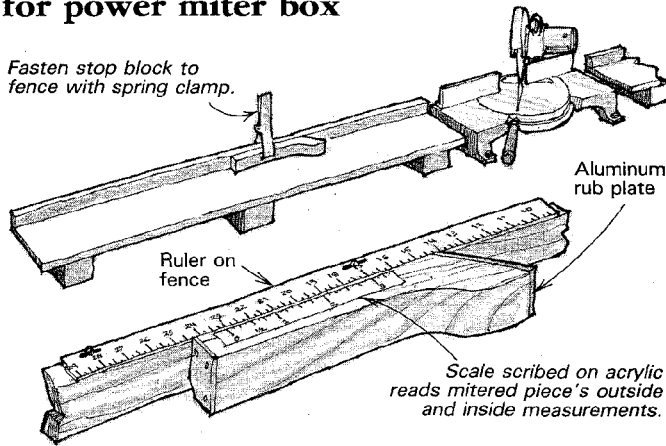

If you cut lots of 45° miters on a power miter box, this device will save you hours of measuring. The scale on the stop block lets you set up quickly for either inside or outside measurements on a mitered frame.

To make the stop block, carefully miter a hardwood 1x2 and handsaw to the shape shown. For a touch of class, install a 1/8-in. thick aluminum rub plate to the face of the block. Screw a 6-in. length of acrylic to the top of the block and carefully scribe a measurement scale into the plastic. The measurement scale should be laid out in inches, but the numbering halved so that 1-in. is marked 1/2 and 2-in. is marked 1, etc. This scale will be used to set inside measurements as explained below.

If your saw doesn't have an inch scale along the fence, mount a metal yardstick to the top of the fence. Use slotted holes so you can fine-tune the position of the scale to reflect exact measurements.

To use the stop block for outside measurement miter cuts simply align the zero mark on the stop block with the appropriate outside measure on the fence scale. To use the block for inside measurements first measure the width of your molding. Find the mark on the stop block that corresponds to the width and align that mark with the inside measure on the fence scale. For example, if your molding is 2-in. wide and the desired inside measure is 19-in. then find 2 on the stop block and align it with 19 on the fence side.

For added convenience, construct the stop block with a square end so it can be flipped and used for cutting pieces with square ends. Scribe a mark on another side of the stop block to align the square end with the fence scale. In use, fasten the stop block to the fence with a spring clamp or a small C-clamp.

—Dean French, Kapaa, Kauai, Hawaii

Preset mortise gauge

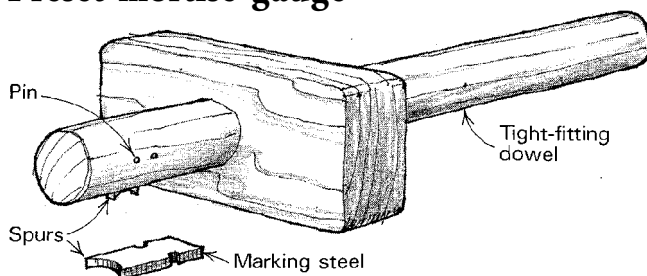

I specialize in making chairs, and realized after a few years that my mortise-and-tenon joints were all just about the same thickness, 3/8 in. To save the time spent setting up my adjustable mortise gauge, I made one with a fixed 3/8-in. setting. The most

important component is a piece of 1/16-in. thick steel ground exactly 3/8 in. wide and shaped as shown, which provides two marking spurs. The steel should always be sharpened on the inside hollow so the outside dimension is not altered.

Fasten the marking steel into a slot in the dowel with rivets or a small wedge. The dowel should be a hard, stiff piece of wood such as oak. I made the body of the gauge from hornbeam, a dense but non-brittle wood. I omitted the usual wedge for locking the gauge at its setting because the dowel fit so tightly into the body. To adjust the gauge, I tap the dowel with a small hammer.

—Stelan During, Texel, Holland

Quick tip: To protect glues and finishing supplies from freezing when I don't have the heat on in my barn shop, I keep them in a foam picnic cooler, in which I mounted a 15-watt light bulb. The cooler stays about 40° warmer than the shop.

—Richard Porter, Groton, Mass.

Swivel joint for coopered doors

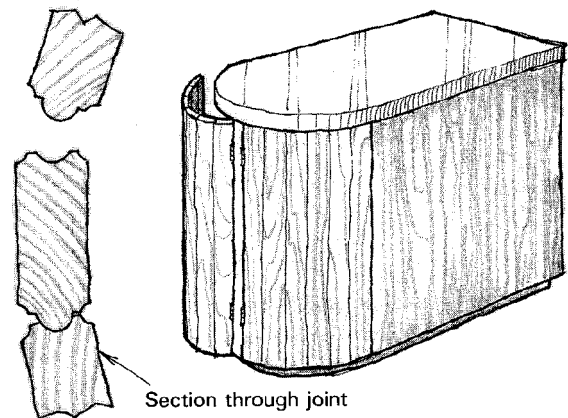

I recently built solid-wood cupboards for our kitchen, and planned to have one counter stand out from the wall like a peninsula. In order to avoid sharp (and potentially painful) corners, I rashly decided that it should have a semicircular end with curved doors. The problem then became how to make two coopered doors of the correct radius. I didn't want to try tapered-brick construction, because any slight error in the taper angle multiplies—in my doors, even 1/2° of error would have thrown the radius off by about an inch.

I eventually hit on the idea of the swivel joint shown in the sketch. This joint, which I made with a router, allows the pieces to be shifted and glued up at the exact radius needed. Note that the male part of the joint is a full half circle, while the female part is of a matching radius but shallower.

I made a temporary gluing jig from chipboard to hold the boards at the proper radius while the glue was drying. I incorporated end stops as well, at the correct width of the door, so that as the pieces were clamped to the radius they would also be pressed tightly together at the joints. During dry-assembly, I fitted the pieces into the jig and carefully planed the outer edges of the door to a perfect tight fit, then glued and clamped the assembly with two web clamps wrapped around both jig and door.

—G.I. Degg, Alsager, Stoke-on-Trent, England

Quick tip: The simplest way to "resilver" a beveled-edge mirror is to scrape off all the old silver and mount a new mirror behind the old glass.

John Sillick, Gasport, N. Y.

Cleaning sawblades, two ways

Saw blades will stay clean longer and clean up faster next time if sprayed with a kitchen non-stick product such as PAM. After spraying, hold a piece of cardboard over the blade to catch the

mist thrown off, while sawing a scrap or two to clear the excess oil from the blade before you use it on good stock.

—David L. Wiseley, Waters, Mich.

To clean the gummy buildup on saw blades, spray the blade with oven cleaner. I use the foaming type that contains 4% lye. Let the sprayed blade stand a while until the gummy deposit lifts, then rinse under the tap. Oven cleaner is powerful, caustic stuff, so observe the warnings on the label. Do not use on aluminum tools.

—G. V. Mumford, Ventura, Calif.

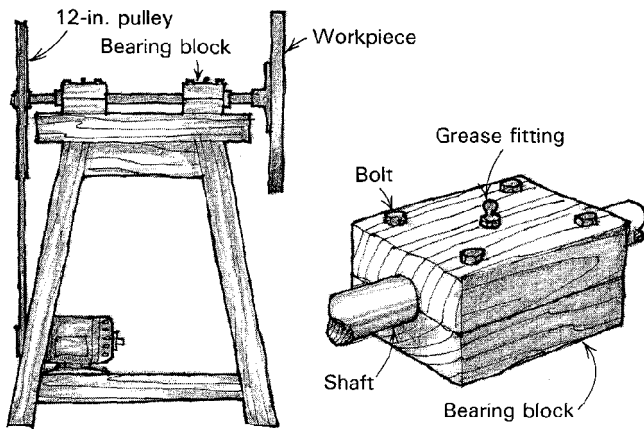

Several years ago, I needed an outboard faceplate lathe for turning large plates. While considering ways to home-build the lathe, I remembered that as a young fellow I had helped my wife's dad as an oiler on a threshing machine. The contraption had a number of low-RPM shafts, which turned in hard-maple pillow blocks.

Adapting the idea to the project at hand, I purchased a 20-in. long, 1-in. thick shaft, fitted a 12-in. pulley (reclaimed from a clothes dryer) to one end, and threaded the other to accept standard faceplates. The shaft runs in two hard-maple pillow blocks, which are lubricated through grease fittings installed in the top.

The whole arrangement is bolted to a sturdy bench, and is run by a motor and belt from below.

—Vie Johnson, Lincoln, Neb.

Heat-bending veneer strips

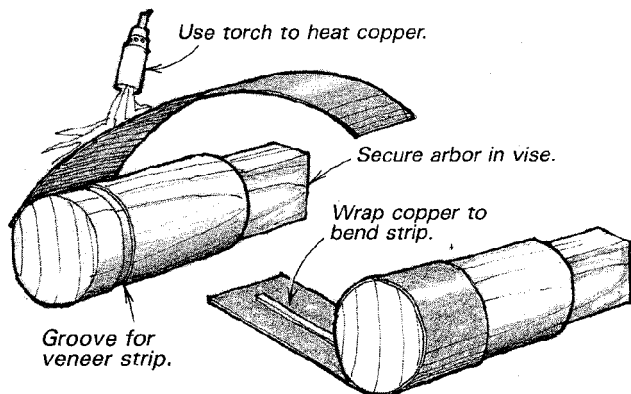

With this simple-to-build device you can bend strips of veneer for inlaying or edging. The chances of cracking or breaking the veneer are greatly reduced.

First turn or saw a wood arbor to a slightly smaller diameter than the bend needed. This tighter radius allows for a little spring back after the veneer has been bent. Cut a square end

on the arbor so it can be clamped in a vise. Fit the arbor with a thick (0.025-in. or thicker), wide copper strap that will retain plenty of heat. You can anchor the strap with tacks or by simply forcing it into a groove. Extend the strap a foot or more so the end will stay cool enough to handle without gloves.

Hold the copper strip away from the arbor and apply the torch, heating the strip well beyond the part that will touch the veneer to reduce the rate at which heat dissipates from the working area. When the strap is as hot as it can be without scorching the veneer, push one end of the veneer under the strap, pull the strap tight and wrap it around the arbor. Hold the strap in place for a minute while it cools.

—Howard C. Lawrence, Cherry Hill, N.J.

Quick tip: When spraying furniture runs are a fact of life, and trying to wipe them only makes a bigger mess. After years of spraying both lacquer and varnish, I finally discovered just last week that you can let them dry and scrape them flush with a razor blade. Then recoat, or simply rub out the finish with pumice and oil.

—Jon Gullet, Washington, Ill.

Drilling accurate holes in large panels

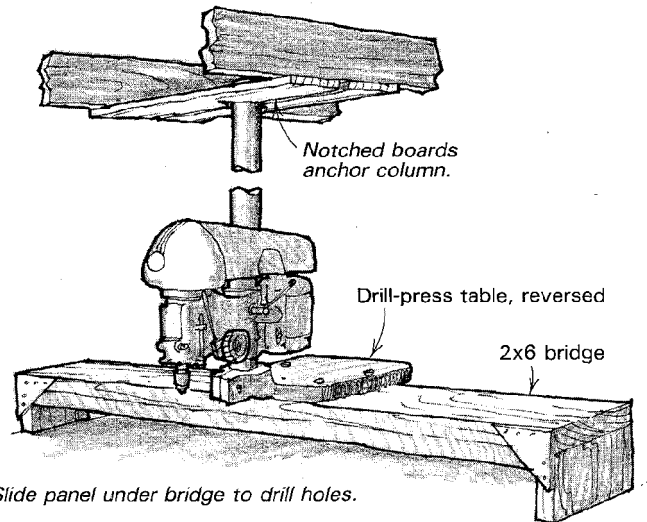

Slide panel under bridge to drill holes.

This idea evolved after I contracted to drill a series of precise holes in a pile of large panels. To support the drill press over the panels I built a 2x6 bridge as shown, and pipe-clamped it to a sturdy workbench. I removed the base of the drill press and used the drill table (reversed and rotated 180°) as an anchor to the bridge. I secured the top of the drill column by installing two V-notched boards on my shop's ceiling joists. Fences and stops fastened to the workbench position the panels for accurately spaced holes.

—John D. Todd, No. Falmouth, Mass.

Quick tip: Our boatshop had to drill two hundred square holes in a board that proved too wide to fit under our floor-model drill press's mortising attachment—the column prevented us from reaching the center of the board. So we remounted the drill-press head upside down on the column, inverted the whole press and bolted its base to the beams in the ceiling. With the board on a bench beneath the press head, we easily drilled the holes.

Jim Beer, Manset, Maine.

Removing rust with vinegar

I have used this method for removing and preventing rust in my old-tool shop for several years. Disassemble the tool and soak it in full-strength natural vinegar. Store-bought vinegar is

standardized at 4% and is not strong enough. Find apple cider with no preservatives, add some "mother" from old vinegar (the cobweb-like stuff) and, in time, the cider will turn to vinegar. After soaking the tool overnight, rinse it under the tap to remove most of the rust. Lightly dress with a wire brush. When dry, spray the tool with transparent aerosol shoe polish to seal the metal and prevent further rusting.

—Charles W. Whitney, Mt. Liberty, Ohio

Improved veneer-shooting board

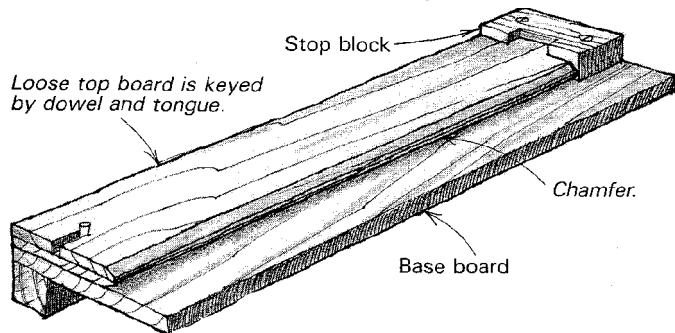

Ian Kirby's design for a veneer-shooting board (*FWW#47*) reminded me of the modifications I have made to mine. Initially I wanted to make the device easier for school children to use, but I soon preferred the new model, too.

One of the difficulties with the original was lining up the loose top board with the baseboard without moving the veneer. My modifications hold the ends of the top board so that it remains aligned with the base. This makes it easy to slip

veneers between the two boards into the correct position for planing. You could construct the shooting board with dowels at both ends instead of the keyed stop, but I use mine for shooting small panels, too—I simply remove the top board and square the panel against the stop for planing the edges.

—Ernie Ives, Ipswich, England

Quick tip: To ensure perfectly sized tenons on turned pieces I turn the tenon slightly oversize and then force an open-end wrench on the tenon to compress it to size. The tenon will fit perfectly then expand later in the hole for a tight joint.

—David Brigham., Mouth of Kesivick, N.B.

Homemade lock screws

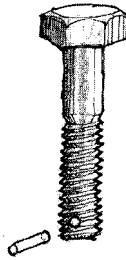

Nylon-insert lock screws are quite effective when you need a bolt that won't loosen in vibrating machinery. But the commercial versions are not available in every size and are expensive. To make your own, simply drill a hole through the bolt near the end and insert a short length of heavy-gauge nylon cord of the type used in grass trimmers. Trim the cord flush with the threads and screw the bolt into the hole. The nylon will crush into a form fit of the threads and will hold beautifully.

—Gordie Mulholland, Streator, Ill.

Methods of Work buys readers' tips, jigs and tricks. Send details, sketches (we'll redraw them) and photos to *Methods*, Fine Woodworking, Box 355, Newtown, Conn. 06470. We can acknowledge contributions only when the final decision has been made. We'll return those that include an SASE.

Two hidden shelf hangers

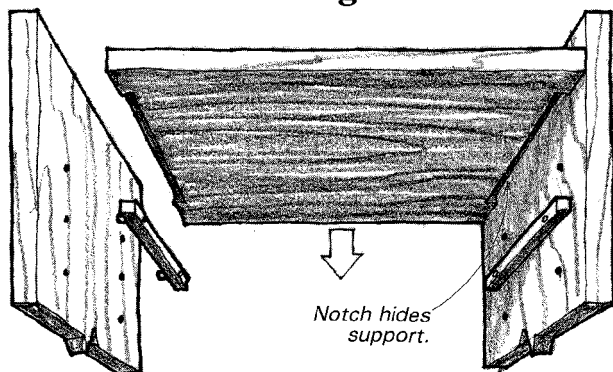

Here's how I provide adjustable shelves in bookcases and hide the unattractive support hardware. First I cut a $\frac{3}{8}$ -in. thick, $\frac{1}{2}$ -in. wide support slightly shorter than the width of the shelf. I peg the support with two $\frac{1}{4}$ -in. or $\frac{3}{8}$ -in. dowels and drill a series of holes on each side of the carcass to match the pegs. Finally I rout a recess into each end of the shelf to accommodate the support so that it is visible only from below.

—Alan Platt, LaGrangeville, N.Y.

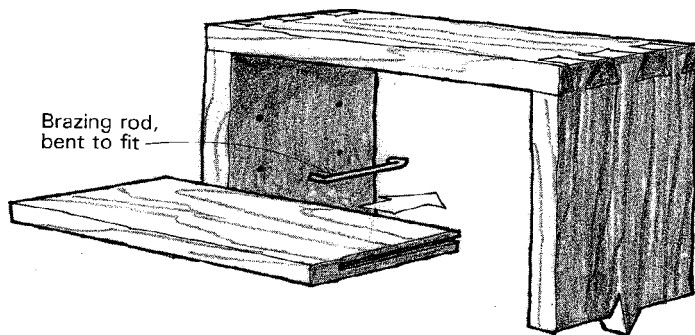

I use these hidden shelf-supports in small wall cabinets and the like. I suppose they could be scaled up for larger carcasses, but they seem better suited for smaller work with, say, $\frac{1}{2}$ -in. thick, 18-in. long shelves.

First bend brass wire into wide U-shapes, as shown in the sketch. I like to use $\frac{3}{16}$ -in. diameter brazing rod. The base of the U must be the same length in all the pieces. I use the jaw width of a small machinists' vise as a handy length gauge. Heat the rod with a propane torch if you have trouble with the rod breaking at the corners.

Next drill a series of paired holes along both sides of the cabinet to fit your brass-rod pins. Cut a $\frac{3}{16}$ -in. stopped groove down the center of each end of your shelf. To install the shelf simply pop two brass supports into matching holes and slide the shelf on from the front. The support is locked in place and is perfectly invisible.

—Fred Gati, Providence, R.I.

Rounding tenons on door louvers

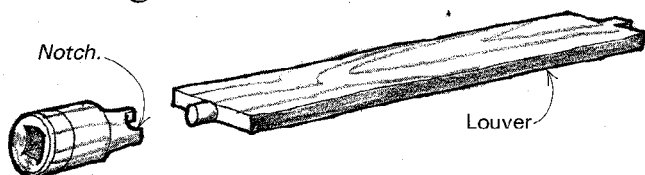

Recently I had to make louvered shutters out of walnut for a custom interior job. Everything was straightforward until I got to the little round tenons on each end of about 500 louvers. When I cut the louvers, I left a $\frac{1}{4}$ -in. square stub on each end, which needed to be rounded to pivot in the door frame.

Stumped, I finally discovered that I could chuck a $\frac{1}{4}$ -in. hex socket in my drill press and it would effectively chew the tenons round. The socket worked fine without any modification, but I had so many louvers to do that I decided to make the cutting action cleaner—I ground a notch in the socket, as shown in the sketch, to form a cutting edge. The edge should be ground at the middle of one of the socket's flats, at the point of minimum diameter.

—Paul G. Carson, Cashiers, N.C.

Patching turned spindles

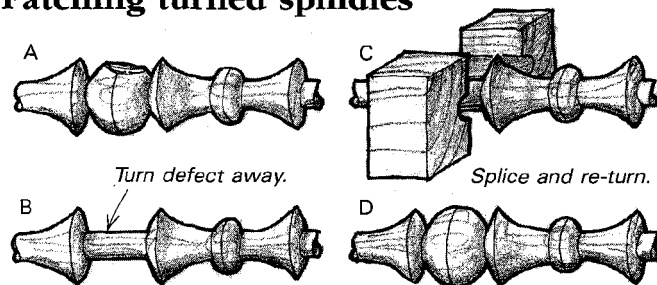

If you mess up a detail in an otherwise good turned spindle, you can cut a small block of similar wood and use it to patch the work, as shown in the sketch. The procedure can also be used to create unusual effects with contrasting woods.

—John Sillick, Gasport, N.Y.

Quick tip: To replace a broken caster on a cedar chest without having to disassemble the riveted metal axle, I made a new wheel, split it into halves, then glued it together again around the axle.

—George W. Addison, Cambridge City, Ind.

Low-cost footswitch

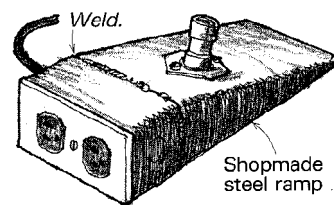

A foot-operated switch is not only a convenience, but also makes many woodworking operations safer. I was able to make mine at a reasonable cost from hardware that I obtained locally. The main part of the unit is a foot-operated starter switch from a farm tractor (I used International-Harvester part no. 64931-h). It has a 400-amp capacity, more than enough for any 110-volt, single-phase motor found in the wood shop.

Begin construction by brazing or welding a ramp-shaped steel plate to a regular surface-mount electrical box. Drill a hole in the ramp and mount the switch just below the box. Wire a standard 110-volt receptacle into the box using heavy (no. 12 or no. 14) electrical cord and a box connector. Connect the cord's neutral and ground wires to the receptacle but route the "hot" or black wire through the switch. Tape the switch connections well to insulate them.

The switch will operate only when foot-pressure is applied and thus functions like a "dead man" control found on industrial machinery. Locate the switch where no one will step on it accidentally, or if that seems difficult, construct a safety cover. You may wish to fasten a wooden block around the ramp to allow a more comfortable foot angle.

—Robert L. Koch, Tarkio, Mo.

Belt sanding concave surfaces

Here's how to modify a belt sander to shape and smooth large-radius concave surfaces, such as a seat on a deacons' bench. Between the belt and the bottom of your sander, you will find a flexible, polished-steel plate that cuts down friction. Simply prepare a plywood shim with dimensions to fit your sander

and one face curved to a slightly smaller radius than your work. Slip the shim under the flexible steel plate. Belt tension will pull the plate to the same curve as the shim, and will also hold the shim in place during operation. I easily sanded a curve with a 3-ft. radius this way, and don't see any reason why tighter curves couldn't be sanded as well. This method wouldn't work very well to dish out a bowl shape, however, as only the edges of the belt would cut.

—Tom Hanson, Victor, Mont.

Centering routed mortises

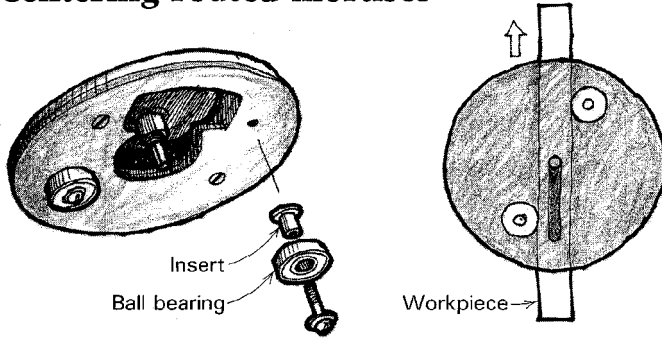

John Birchard's door-making article (*FWW* #49) prompted me to send this mortise-centering idea I've used for quite awhile. Like Birchard, I use a plunge router to cut mortises in the stiles of frames. However, instead of using a fence to center the mortise, I attach two small ball bearings under the router base. On the Hitachi router I use (and most other routers), the subbase is attached with four screws. I remove two diagonally opposite screws and replace them with the bearing shown in the sketch. The bearing rides on a shopmade press-fit insert that is slightly longer than the bearing's thickness, and that has an inner diameter to fit the bolt. The flange at the end of the insert can be machined as part of it, or it can be a separate washer. It need only be thick enough to prevent the bearing from rubbing on the router base.

In cutting the mortise, the bearings ride against the sides of the stile, automatically centering the mortise in the work. The size of the bearings is unimportant, as long as both are the same. Note that when cutting mortises near the end of the stile you must have an excess length, a "horn," for the bearing to ride on. Leaving a bit of excess to be trimmed off later is good practice anyway.

—David Ring, Yodfat, Israel

Quick tip: When raising the grain while sanding chest and table tops, try rubbing alcohol. It does as well as water, but dries much faster.

Karl Dittmer, El Reno, Okla.

Octagon marking gauge

Many craftspeople know the traditional method for marking a square to make an octagon: First draw diagonals as shown in the sketch at the top of the next column. Then, with a compass set to one-half the diagonal, draw arcs from two corners. Reset the compass and walk it around the square to mark the corners of the octagon.

Repeating this procedure for different-size workpieces can be tedious. So here's a gauge, borrowed from boatbuilding sparmakers, that will scratch the lines you need along the length of a square workpiece of any width (less than its capacity), even if the workpiece tapers.

To make the gauge, first cut a cardboard square equal to the largest section you expect to deal with. On the square, draw diagonals and arcs to locate the two scribe points, as shown in the sketch. From a stout piece of hardwood make a U-shaped gauge body to fit over the cardboard square. Drive nails in the

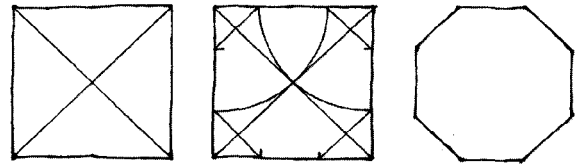

Scribe diagonals; then compass shows true octagon.

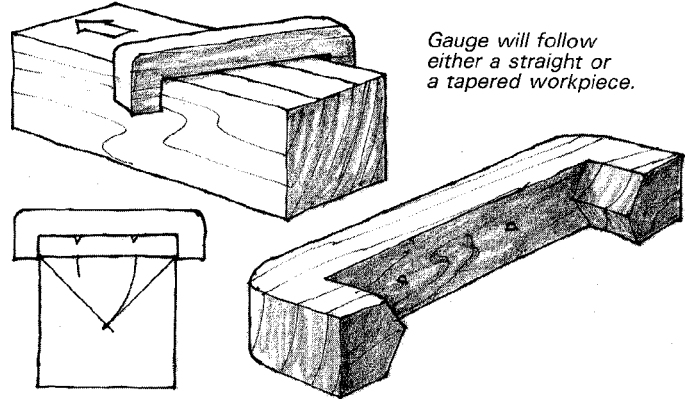

gauge at the proper locations and sharpen. To allow the gauge to be used for smaller work, cut the ears into a prow shape as shown in the drawing.

To mark the square workpiece, angle the gauge until it bears against the sides and draw it along. If the wood tapers, the angle of the gauge will change but the proportions of the spaces across the wood will remain correct.

—Percy W. Blandford, Stratford-upon-Avon, England

Quick tip: To center the bit when cutting a mortise with a router, chuck a V-grooving bit in the router (you could substitute an old drill bit ground to a point). With a pointed bit in the router, it's easy to adjust the router's fence so that the bit is over the centerline on the stock. Now remove the centering bit, replace with the mortise bit and rout the mortise dead-center.

—David V. Nicholson, Vancouver, B.C.

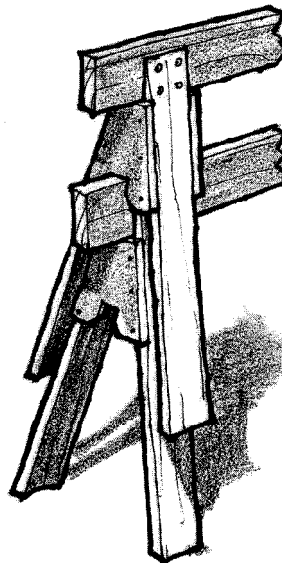

Stacking sawhorses

When my husband, John, and I built our sawhorses, we took a lot of Sam Allen's good advice on the subject (*FWW* #24). But we found that by modifying his basic design slightly the horses were much easier to deal with around our shop, a place that always seems a bit too crowded. To allow the horses to be stacked for storage, we notched and beveled the plates of ½-in. Baltic birch plywood that reinforce the legs. Only a touch of clearance is required for a comfortable and stable fit. Our horses stack six or eight high with no wobble.

—Carolyn Grew-Sheridan, San Francisco, Calif.

Waterproofing turned vases

To prevent water damage to turned flower vases, I have tried built-up plastic finishes and even melted candle wax. Neither will last permanently and a failure will ultimately ruin a beautiful piece of wood. Glass test tubes, available at chemistry sup-

ply stores, provide the solution. They are available in a wide range of diameters and lengths to suit your needs. With a sharp spade bit, drill a hole in the vase slightly deeper than the test tube you will be using. There is a lip on the tube that will rest on the surface of the vase and allow for easy removal for cleaning later.

—William D. Vick, Jr., *Rochville, Va.*

Jig for honing two jointer knives

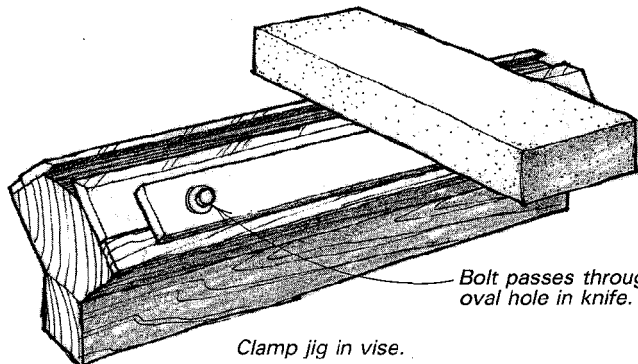

My Inca jointer has two 10¼-in. knives, which cost \$12 to sharpen. Not satisfied with the price and inconvenience of that, or with the homemade sharpening devices I'd seen in the *Methods of Work* column, I built the device shown here, which allows manual sharpening of both blades at once. This mostly-wooden jig is inexpensive, and accurate if smooth strokes are used along the full length of the knives.

To make the jig, start with a piece of straight-grained, 2-in. square hardwood as long as your knives. Chamfer the top of the block so that the bevels will be parallel to the top of the block. Glue on wooden strips, slightly thinner than the thickness of the blades, to act as stops. Make sure these strips align the blades so that the beveled edges are in the same plane. Cut and drill steel strips and install them as shown in the sketch to hold the blades securely.

For safety's sake wear a glove and be careful. A slip could cause a nasty cut.

—John Toffaletti, *Durham, N. C.*

Remedy for a worn miter gauge

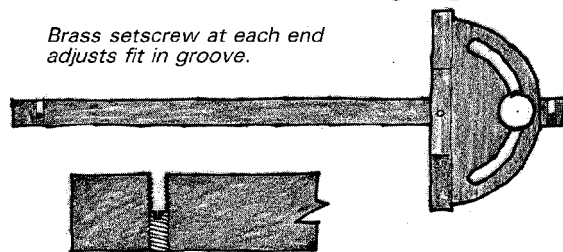

Here's a better way to take out the slop in a loose or worn miter gauge rail. It's certainly a more elegant solution than peening the rail as has been suggested in a past issue. First dismantle the gauge. Drill and tap a hole across each end of the rail bar to accept a ¼-in. setscrew. I make my own brass setscrews by cutting the head off a brass bolt and hacksawing a screw slot. Install the setscrews in the bar and adjust them until the rail fits the slot perfectly.

—Harrie E. Burnell, *Newburyport, Mass.*

Self-clamping featherboard

Most woodworkers recognize the value of using a featherboard when feeding narrow stock through a saw or shaper. But too often we fail to use the device because it's simply too much trouble to clamp and adjust. This featherboard is no more trouble to adjust and use than a rip fence. It has paid for itself

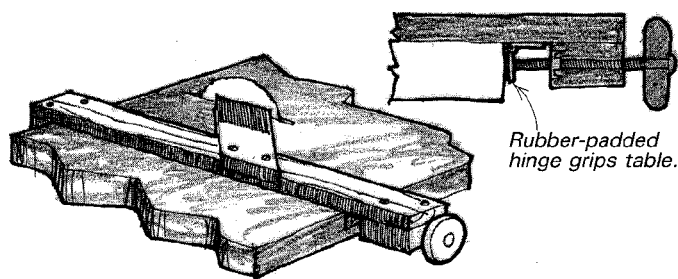

many times over in time and material savings. My version grips the table by means of a rubber-padded hinge, activated by a bolt running through a T-nut, as shown in the sketch—the handwheel is held on by epoxy. You could adapt the design to grip securely on virtually any rip fence rails.

—Bert Whitchurch, *Rockaway Beach, Mo.*

Quick tip: If you have to put screws in tight places where a regular drill won't fit, such as between close-set drawer supports, a spare Jacobs chuck makes a handy short drill handle for making a pilot hole. It also makes a matching screwdriver if it's fitted with a short blade such as those meant to be used in electric drills. My spare chuck usually has a countersink bit in it while I work. A couple of turns by hand will countersink any pilot hole in a jiffy, much faster than constantly changing bits to do the job.

—Nicholas Cavagnaro, *Orofino, Idaho*

Lumber dollie

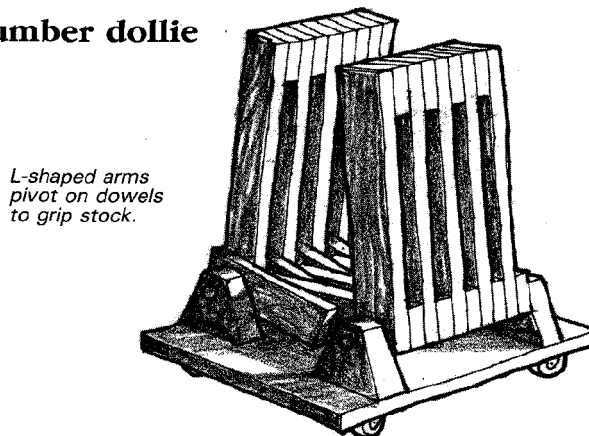

Working single-handed in a small workshop, I found it tiring and awkward to move numbers of 4x8 sheets of plywood or large planks from the delivery truck to my machine area. So, I built two of the "bogies" shown here from scraps and inexpensive heavy-duty casters. They have saved me hours of back-breaking work.

First I laminated L-shaped blocks, about 18 in. tall and 8 in. wide at the base, from plywood. Then I drilled a ¼-in. hole through the blocks and mounted them to the base so they could pivot on dowels, as shown.

To use the dollie, spread the arms of the blocks to take the sheet of plywood, which is lowered in. The weight of the wood then levers the arms down to clamp the plywood in place. One dollie, placed in the center, is enough for most loads, but for extra heavy or awkward pieces you can use two.

—Chris Yonge, *Edinburgh, U.K.*

Methods of Work buys readers' tips, jigs and tricks. Send details, sketches (we'll redraw them) and photos to Methods, Fine Woodworking, Box 355, Newtown, Conn. 06470. We can acknowledge contributions only when the final decision has been made. We'll return those that include an SASE.

Improved forge design

When I began making my own tools a few years ago, I decided to build a forge using a barbecue grill and a vacuum-cleaner blower, based on a design in *FWW* #9. I had some problems with that forge, but the one shown here, intended for outside use, eliminates them.

The main components are an old barbecue grill pan, firebricks for the firebox, a 55-gallon drum that acts as a hood, and two lengths of 6-in. stove pipe to ensure a good draft.

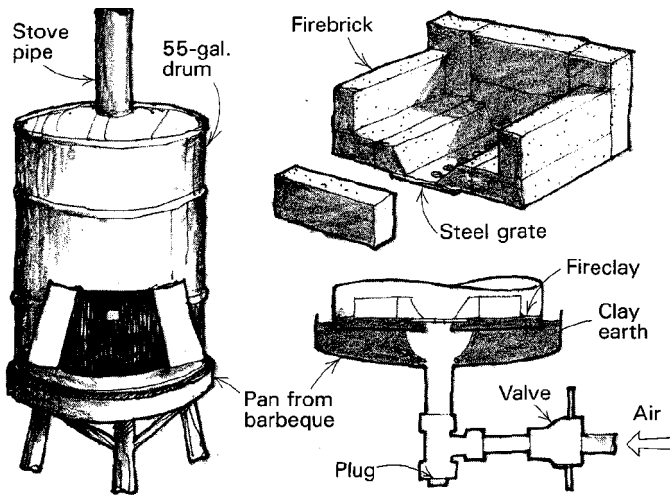

Construct the forge as shown in the sketch, connecting the blower with ordinary steel pipe. Install a valve in the blower line (I used a simple sliding wooden plate) to vary or cut off the air, and set a plug at the bottom so you will be able to remove ashes when necessary.

The size of the firepit can be changed, of course, but the configuration illustrated has been the best for my work. Any place that isn't exposed to heat (below the firebrick) can be filled and sealed with hard-packed earth and red clay, of which there is an abundance here in Arkansas. This will save a lot of fireclay, which I used only to seal around the firepit.

After the forge is together, build a roaring fire in the thing until it's good and hot. Check the next day for air leaks by turning on the blower and hanging a loose thread over suspicious cracks. Patch these with clay mud or fireclay.

Although the barrel hood provides enough shade so that I can usually judge forging heat by eye during full daylight, I found it best to save tricky work until evening. The hood also provides good protection from wind.

In working the forge with small pieces of steel, you can save coal by damping the back portion of the fire with water. If the work is longer than the depth of the forge, remove the rear firebricks and push the work through the small rear opening cut into the back side of the barrel.

A couple of safety reminders are to use only firebricks in the firepit—ordinary bricks may explode when heated rapidly. Also, bend the corners of the cut-out door in the barrel and smooth any rough edges. In the flurry of forging, it's easy to run into sharp edges.

—Jim Young, Omaha, Ark.

Sliding frame-to-carcase joint

I don't claim to have invented this joint. It has surely been used before, but I have never seen it explicitly described. The joint is designed to install parting frames, such as drawer supports, into a solid wood carcase. It provides a sliding action to allow the solid wood carcase sides to expand and contract with changes in relative humidity.

The double tenon at the front of the frame is glued into a

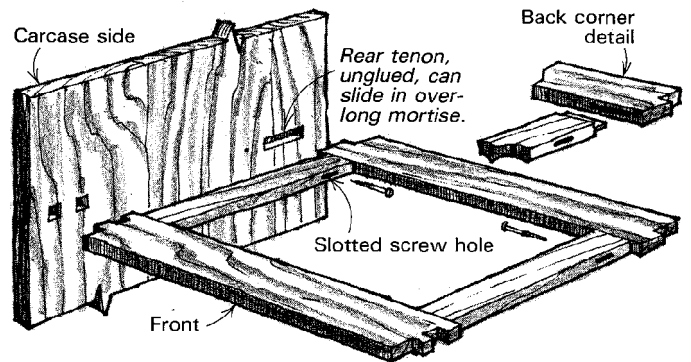

double mortise in the carcase, locking the frame in position (a single tenon would be glued mostly to endgrain in the carcase sides, which doesn't make for a very good glue joint; the double tenon has twice as much side-grain to side-grain gluing area). At the back, a sliding tenon in an extra-long slot and a screw through a slotted hole allow the carcase sides to shrink and expand without damage.

—Nicholas Cavagnaro, Orofino, Idaho

Quick tip: Use chalk powder to highlight scribed lines. It not only shows up well even on light-colored woods, but it also tells you when your sawcut is splitting the line—it dusts out ahead of the teeth.

—Dennis Sweeney, Pittsburgh, Pa.

Magnetic duplicate cut-off aid

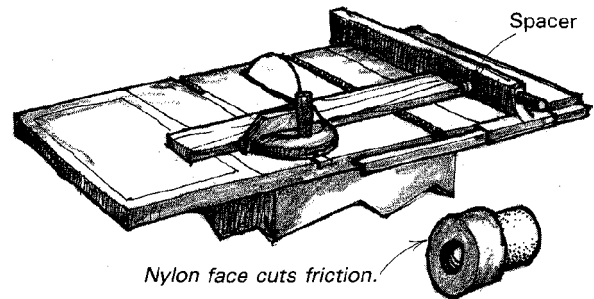

This gadget has saved me a lot of time when cutting duplicate lengths on the table saw. It's a spacer that ensures clearance between the cut-off stock and the rip fence, thereby avoiding the danger of kickback. My spacer is simply a round magnet with a threaded hole through it. These magnets should be standard items at your local hardware store or five-and-dime. Screw a short length of nylon rod or other slippery alternative to the magnet and cut the unit to exactly 1 in. in length. I trimmed mine to length by facing it on the lathe, but other methods would work just as well.

To use, just pop it on the rip fence, set the fence to the desired dimension plus 1 in., butt your stock against it and cut. Best of all, the spacer is always handy—stuck on the back side of the fence.

—Richard Bolmer, Anaheim, Calif.

Quick tip: You can get good socket chisels at flea markets, but many have lost their handles. Turning a new handle is easy enough, but duplicating the socket taper is tricky. I pour the socket full of molten lead. When it cools I remove the plug and use it as a pattern.

—Ralph Zwiesler, Freesoil, Mich.

Laminating sandpaper for flatness

Small items are always difficult to sand. No matter how careful you are they never seem to come out flat. Try using rubber cement to hold the sheet of sandpaper to a scrap piece of laminated countertop from your local cabinetshop. Sink cutouts

seem always to be in plentiful supply. The sandpaper will now be flat and you can use both hands to steady the piece being sanded. When the sandpaper is worn, simply peel it up and remove the rubber cement from the laminate by rubbing it with your finger. —Robert A. Prive, Essex Junction, Vt.

Quick tip: If you can't avoid installing screws in end grain, drill an oversized hole and tap plastic anchors into the end-grain piece. The anchors will expand and ensure a firm grip. —Christine and David Springett, Rugby, Eng.

Frame joint for a job-site table

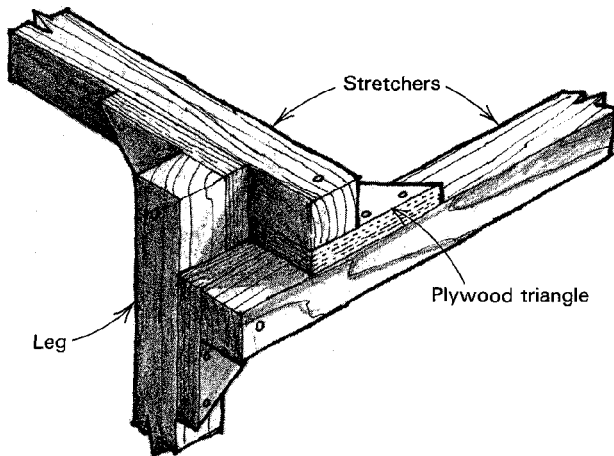

It's often useful to be able to quickly construct a solid table or bench frame at the job site. I simply cut legs and stretchers to length from scrap, then join with three 45° triangles of 3/8-in. plywood at each corner, glued and nailed. Variations of this joint—with a little mathematical figuring and diamond-section ribs—can be used for quick geodesic domes and other timber structures. —Chris Yonge, Edinburgh, Scotland

Large-diameter caliper

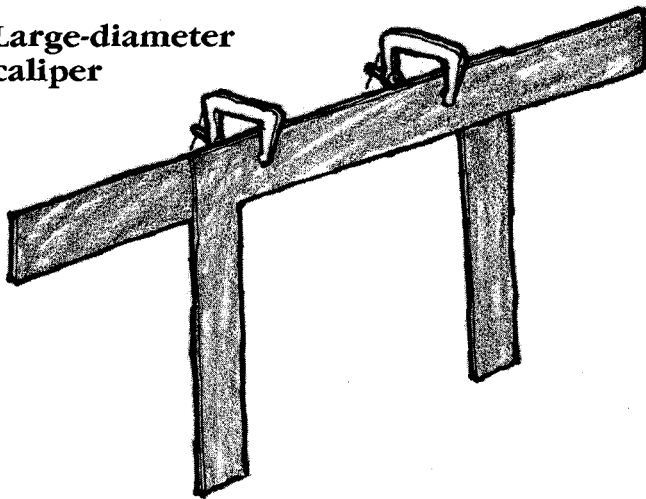

Two framing squares can be used for measuring and gauging large diameters on lathe pieces. To use the squares as a fixed-size gauge, clamp them together as shown in the sketch. The framing-square gauge is actually more rigid than a large caliper.

To use the squares for measuring, leave off the clamps and simply slide both squares until they bracket the work. Then you can read the diameter on the inside scale on the back of one of the squares. With a standard 16-in. by 24-in. square you can measure up to 28 in. easily. —Alan Dorr, Chico, Calif.

Jointing with a circular saw

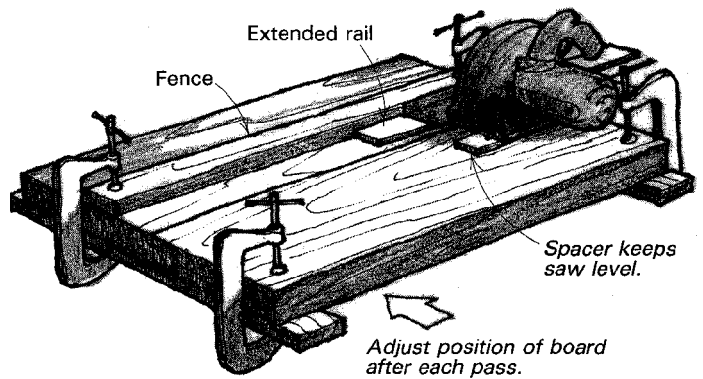

Faced with the problem of jointing two 2x10 lengths of sugar pine for a carved sign, and not having a jointer, I used this method to produce an almost perfect joint.

First I bolted an 18-in. oak rail and a spacer of equal thickness to the base of my circular saw, as shown in the sketch. The rail acts as an extension to the base, ensuring the blade will run parallel to a straight fence. I replaced the combination blade with a hollow-ground planer blade.

Next I clamped the two 2x10s edge-to-edge on a level surface and clamped a hardwood fence on top of one of the planks. The fence was set so that the saw would pass right down the meeting line of the planks, removing some material from each plank.

After each pass of the blade I pushed the two planks together, readjusting the fence as necessary, and took another cut. After five or six passes, the joint was ready to be glued.

—Robert P. Cromwell, Royalston, Mass.

Quick tip: Almost any sort of glue spreader will do the job, but in my mind, serrated plastic knives are superior to all other devices. Just wipe off the mustard and you're ready to spread glue. —J.A. Breneman, Richmond, Va.

Homemade edge-gluing clamps

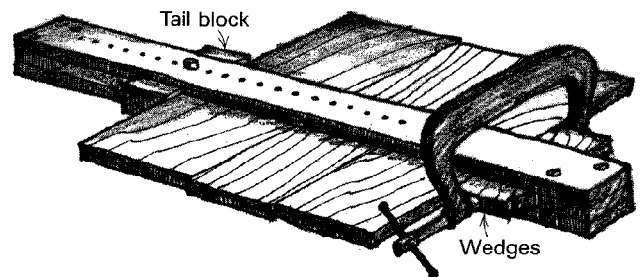

Here's an inexpensive but effective homemade clamp for edge-gluing stock. Unlike a pipe clamp, it won't fall off the workpiece while you're fitting up and it pulls evenly on both sides of the stock, ensuring flat panels. To use, pin the sliding tail block in an appropriate place, then apply pressure by screwing down a C-clamp across the wedges. Scraps of waxed paper will shield the clamp from glue squeeze-out.

—Bert Whitchurch, Rockaway Beach, Mo.

Versatile mylar

I recently discovered a drafting "paper" made of transparent mylar, which has proved to have many interesting applications around my woodshop. It is available in rolls or sheets from art supply stores, and comes in various thicknesses from 0.003 in. to 0.008 in.—this makes it handy as shim stock, and the heavier weight makes good template material, too. One side is frosted

so that it will accept pencil or ink and the other side is glossy. You can buy it clear or with a graph-paper pattern for making drawings. I find that for small projects I can draw the plan on the frosted side, turn the sheet over, and glue up the work on the shiny side—the glue won't stick to it and I can align the pieces perfectly with the drawing. Mylar cuts well with a sharp knife or scissors, is durable and has very good dimensional stability. It is also superior to waxed paper for protecting surfaces from glue squeeze-out because it is stiff, doesn't wrinkle and tends to stay put. —Norm Capen, Granada Hills, Calif.

Flexible drum sander

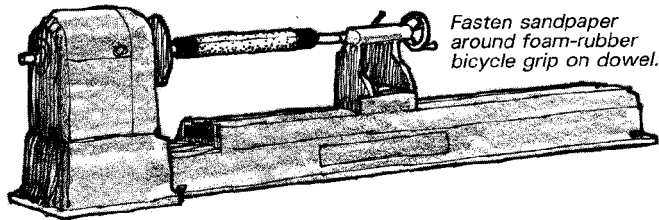

This inexpensive drum sander can be made by slipping a foam-rubber bicycle grip over a $\frac{5}{8}$ -in. dowel. The grip will stay nicely in place without adhesive. Notch and center-punch the dowel so it will run between centers on your lathe. Form sandpaper into a cylinder, scrape the abrasive off the bottom edge of the seam and hot-glue the sandpaper around the foam-rubber. The sander has just enough give not to sand flat spots on curved surfaces but is firm enough to make smoothing fast and easy. I use a vacuum and homemade sawdust collector to pick up the dust. —Gene Austin, Blue Bell, Pa.

Adjustable protractor

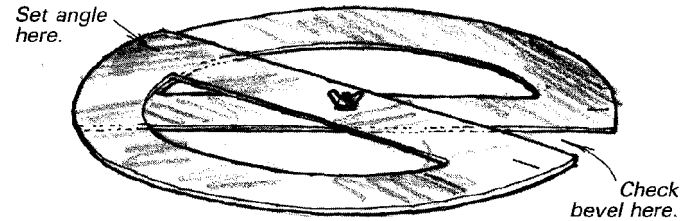

An accurate adjustable angle gauge can be made quickly and inexpensively from two identical dime-store plastic protractors. With a tiny bolt and wingnut, fasten the two protractors together by enlarging the holes already made at the center. I find the device quite useful when cutting angles and also for checking the bevel angles on chisels and turning tools.

—John Rocanova, Bronx, N. Y.

Stripping with sawdust

To remove an old varnish finish quickly and neatly, first apply varnish remover and keep it wet until the finish has softened, then use handfuls of sawdust to remove the sludge. The sawdust acts as an abrasive to effectively clean off the old finish. In addition, it absorbs most of the mess and makes cleanup an easy broom-and-dustpan task. —Bill McNutt, Guthrie, Okla.

Methods of Work buys readers' tips, jigs and tricks. Send details, sketches (we'll redraw them) and photos to Methods, Fine Woodworking, Box 355, Newtown, Conn. 06470. We can acknowledge contributions only when the final decision has been made. We'll return those that include an SASE.

Improved featherboard

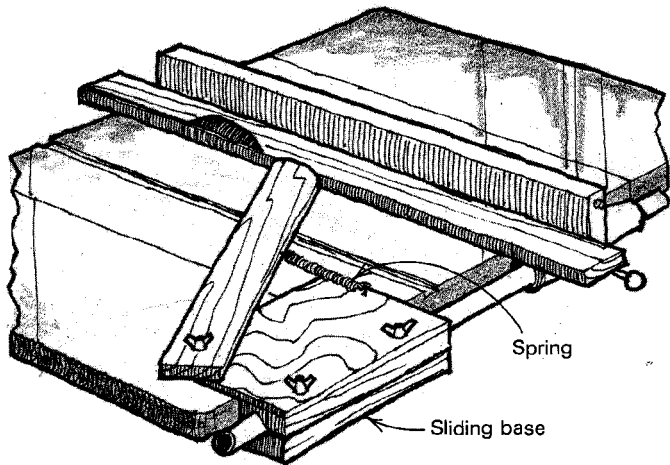

I finally got tired of the clumsy business of clamping a featherboard to the saw table, and then tediously reclamping it each time to adjust it to the width of a new workpiece. This simple solution took less than an hour to make and works perfectly.

It consists of two parts, a featherboard and a sliding base assembly. Custom-fit the sliding base to your front fence rail so that it can move anywhere along the front edge of the saw table and be locked in place with wingnuts or wedges. My sliding assembly is made to fit the T-slots of the Rockwell Unifence arrangement (the one in the drawing is shown on the more usual Unisaw rails). The featherboard pivots on a bolt and is kept in tension against the workpiece by a spring.

—Arthur Kay, Tucson, Ariz.

No-hassle octagon ripping

After spending a week making a marking gauge for laying out octagons on any size stock, I had a flash of inspiration. This method, which requires no gauge, will allow you to rip perfect octagonal cylinders.

First determine the size you want the finished octagon to be, then rip your stock to a perfect square. Make a new wooden insert for your tablesaw and, with the saw blade tilted to 45°, bring the blade up through the new insert to the maximum depth of cut. Retract the blade to the depth needed to cut the corners off the square stock. A precise kerf line should now be visible fore and aft of the blade in the tablesaw insert.

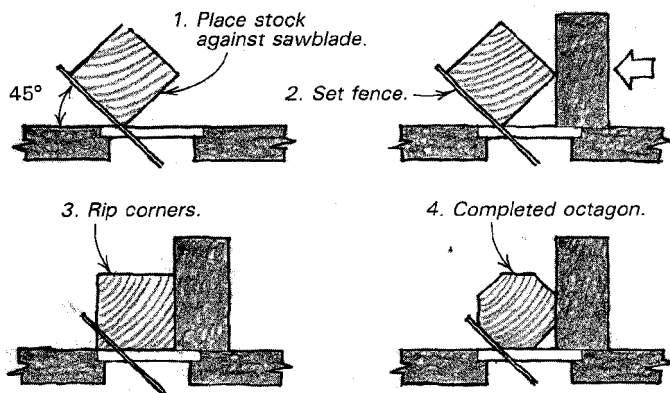

Now lay your square stock against the blade with the corner of the stock right on the kerf line in the insert. Bring the rip fence up to the stock so that it just touches the corner (as shown in the sketch) and lock. Lay the stock flat on the table against the rip fence and rip off the corners to produce a perfect octagon.

—L.A.D. Colvin, Satellite Beach, Fla.

Octagon formulas and jig

The special jig and the formulas below will enable you to cut an octagon with each side equal to a predetermined length. The jig is a piece of plywood with two fences screwed to the top at 45° to the edge.

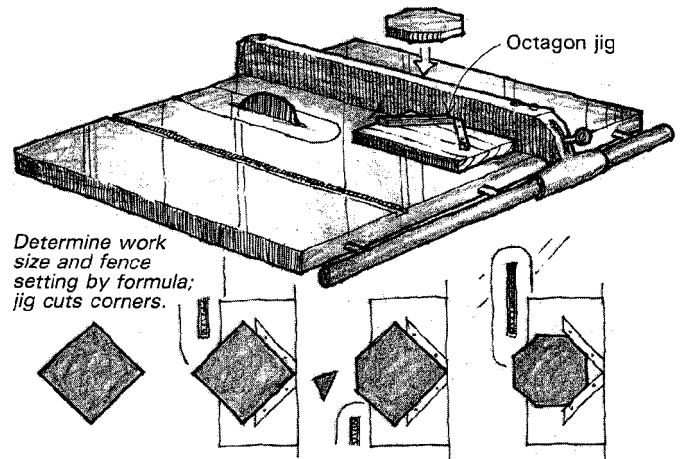

To use the jig, first determine the desired length of one side of the finished octagon O . Calculate the square size S needed from the formula $S = 2.414O$, and cut a square S inches on each side. Now calculate the rip fence distance R from the formula $R = 2.914O$, and set the rip fence at this distance. Place the square in the jig and rip off all four corners in turn to produce a perfect octagon.

Example: 3 = desired length of one side of octagon. $S = 2.414 \times 3$, or $S = 7.242$. $R = 2.914 \times 3$, or $R = 8.742$.

—Rafik Eskandarian, Fresno, Calif.

Faceplate centering device

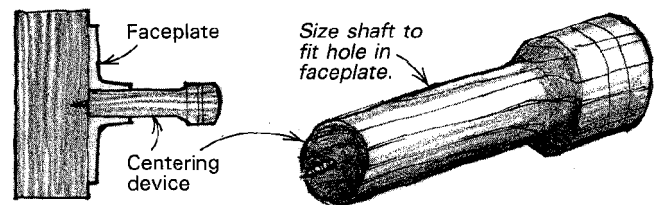

This simple little device will help locate a faceplate over the center of a workpiece. To use, first center-punch the workpiece. Then screw the centering device into the workpiece through the center hole of the faceplate to hold it in position while you drill the pilot holes for the fastening screws.

—W.I. Newcomb, Arlington, Va.

Quick tip: When my router table isn't in use, I keep a 35mm film canister over the bit. It protects the cutting edges, keeps airborne dust from falling into the motor and reminds me to keep junk off the table.

—L.D. Fredrick, Aspen, Colo.

Recipe for razor-sharp carving tools

During my 50 years of carving I have collected some 280 edge tools which, for the kind of carving I do, must be kept sharp enough to shave with. To prepare the edge, I use three grades of progressively finer India stones. But the real trick is to strop the edge to a mirror finish. For this you'll need a couple of pieces of sole leather from the local shoe shop and an abrasive product called Cloverleaf Abrasive Compound, which was originally manufactured for grinding engine valves on Model T Fords. It is a smooth-cutting abrasive suspended in a Vaseline-like jelly. Cloverleaf is still manufactured today in seven different abrasive grades and can be bought in most auto

supply stores. You will need two grades—I use one up from finest and two down from coarsest.

First soak the pieces of sole leather in light lubricating oil. Then rub about a teaspoon of the finer abrasive into the smooth side of one piece and a like amount of the coarser abrasive into the rough side of the other piece. Bend the leather into the profile of the cutting edge and strop both the inside and outside of the carving gouge to produce an incredibly sharp edge.

—Ford Green, San Antonio, Tex.

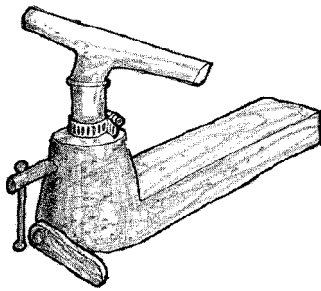

Toolrest height stop

When you need to maintain one height setting for your lathe's toolrest, but have to constantly change its angle (as when faceplate turning) tighten a small hose-clamp on the toolrest's shank. This will prevent it from slipping down as you adjust it.

—Brian P. Mitchell, Somerset, Colo.

Woodcarver's clamping system

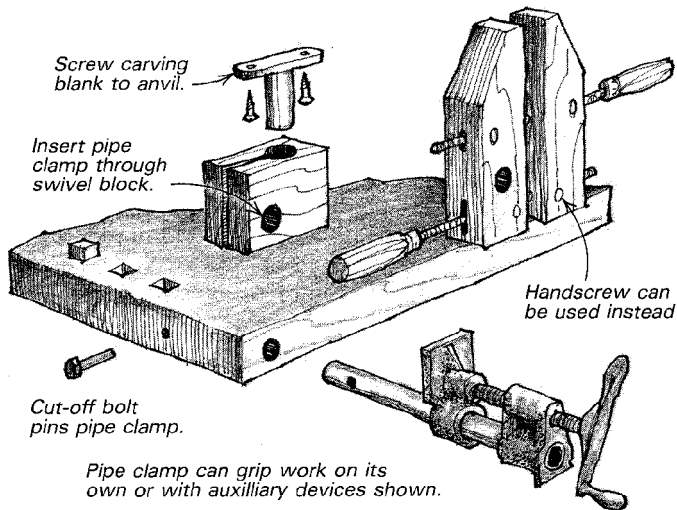

I originally designed this clamping system for holding half-size duck carving blanks. With a couple of additions, the system is quite versatile and can be used for many other woodworking jobs as well. The basis is a standard pipe-clamp head mounted on a stubby pipe, about 8 in. long. Drill a pipe-sized hole into the edge of your bench near the corner. If your benchtop is not thick enough to provide a strong lip above the hole, glue a block to the underside of the top to make the total thickness 2 in. or so. Now drill a $\frac{1}{2}$ -in. hole from the edge of the benchtop through the pipe and install a sawed-off $\frac{1}{2}$ -in. bolt to pin the pipe.

The clamp will serve quite well alone or with a bench dog as a light-duty vise. But two easy-to-build additions increase its uses. One addition, shown in the sketch, is a swiveling block and anvil for carving in the round. Insert the pipe clamp through the hole in the swiveling block before pinning the clamp into the bench. Then, work mounted on the anvil can be turned and swiveled to virtually any angle before the pipe clamp is tightened to lock it in place.

The second addition is simply a standard handscrew drilled so it can be slipped over the pipe. The clamping system can be set up or removed from the bench in just seconds.

—Wallace C. Auger, Fairfield, Conn.

Routing tambour grooves

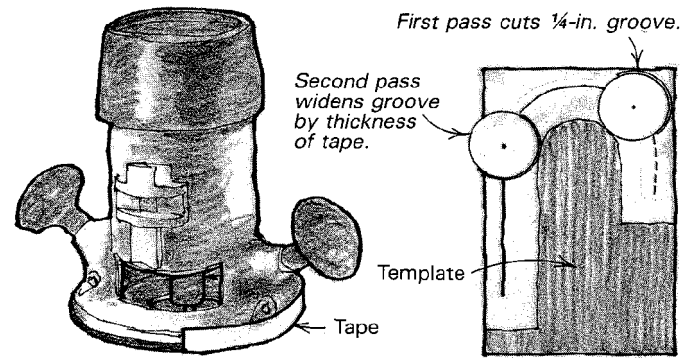

I recently built a set of display cases that had tamboured doors with $\frac{1}{4}$ -in. thick edges. I wanted the grooves in which they ran to be $\frac{1}{32}$ -in. wider so the tambour wouldn't bind. To accomplish this I applied iron-on veneer edging tape around half the radius of my router base. To cut the groove I ran the router base along a template using a $\frac{1}{4}$ -in. straight bit. On the first pass I kept the router's original base against the template. On the second pass I rotated the router so the taped portion of the base bore against the pattern, thereby adding about $\frac{1}{32}$ in. to the groove width.

—Andrew Dey, Wallingford, Conn.

Quick tip: When tablesawing, I was always looking for my metal ruler to measure one thing or another, until I epoxied a magnetic door catch to it. Now it's always right there, stuck to the side of the saw. The door catch makes a convenient handle, too, for moving the ruler around, so much so that I went back to my shopmade device even after I'd gone and bought a commercial version.

—Dustin Davis, Frostburg, Md.

Plywood carrying handle

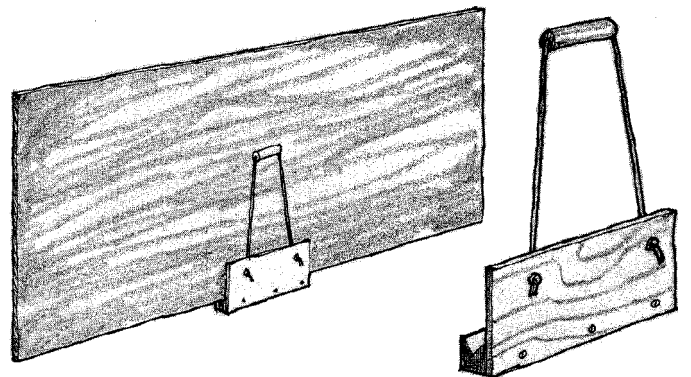

Anyone who has single-handedly maneuvered a full sheet of plywood or sheetrock through a congested worksite or a doorway will appreciate this easily made gadget. The lifter is nothing more than a foot-long V-grooved block screwed to a scrap of $\frac{1}{4}$ -in. plywood. Adjust the length of the sash cord so the carrier is a few inches off the ground with your arm fully extended. To use, reach over the plywood sheet to hook the lifter under the lower edge into the center of the sheet. Lift and carry with one hand—the other hand remains free to open doors.

—G. O. Haffmann, Cheshire, Conn.

Methods of Work buys readers' tips, jigs and tricks. Send details, sketches (we'll redraw them) and photos to Methods, Fine Woodworking, Box 355, Newtown, Conn. 06470. We can acknowledge contributions only when the final decision has been made. We'll return those that include an SASE.

Screw plugs on a strip

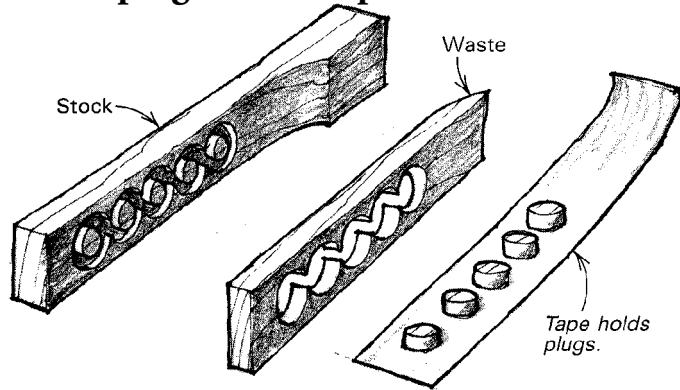

After using the plug cutter to cut a row of shallow plugs for screw hole covers, tape the row with masking tape and rip as required with the bandsaw. The result, as shown in the sketch above, is a neat strip of shallow plugs, all with the same grain direction, ready for installation right off the tape.

—Robert M. Vaughan, Roanoke, Va.

Countersinking in cramped quarters

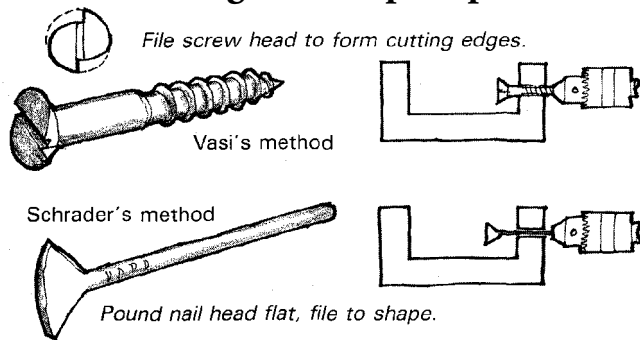

Here's a way to countersink a screw hole on the inside of a small drawer or other cramped space that you can't get a drill into. File both sides of a screw head to produce cutting edges, as shown in the top sketch, above. Insert the screw in the hole from the inside and chuck the screw's threads in a portable drill. A few revolutions will produce a perfect countersink.

—James Vast, Williamsville, N.Y.

To countersink holes for wood screws when you don't have enough clearance for a drill, flatten and spread the head on a 10-d common nail. File the flat to the proper angle and cut the point off the nail. Poke the nail through the hole from the inside and chuck the shaft in an electric drill.

—Robert H. Schrader, Carrollton, Ohio

Preventing panel clamp-up buckle

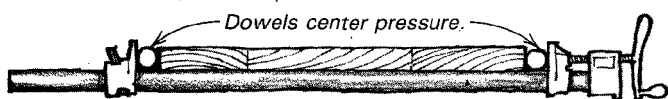

When clamping up boards to make a panel, pipe clamps can ride up on the fixed jaw causing the pressure to be uneven and the panel to buckle. This is caused by the angle of the jaw changing as the pressure comes on. If this bothers you, take a dowel having the same diameter as the thickness of the panel and lay it between the jaws and the work. Now the pressure will be applied on the center of the panel edge just where it should be. The dowel will likely dent the edge, so you may want to add a piece of scrap as a buffer.

—Henry T. Kramer, Somerville, N.J.

Mortising the throat in wooden planes

Although I started woodworking in the usual way—feeding wood to sophisticated machines, sanding, polishing and spraying—after a few years I was really fed up with the dust and dullness of it. Around that time, I chanced on Krenov's *A Cabinetmaker's Notebook*. Needless to say the part on planing caught on with me. From then on the stroke of the plane has been the finish of my work.

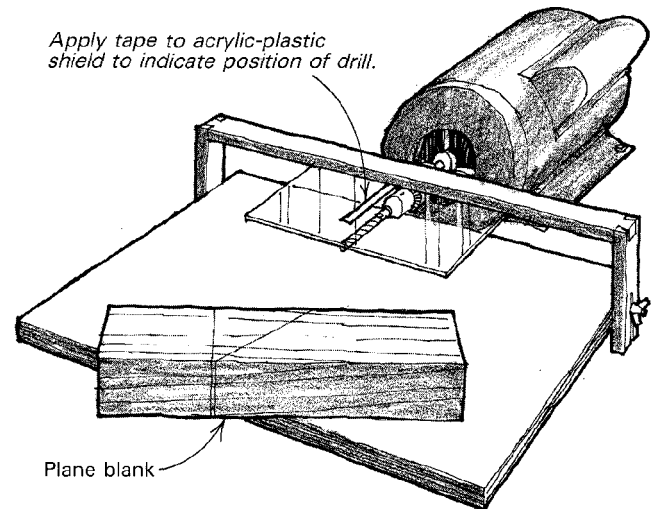

I like to make my planes from one chunk of wood. It is an unfounded habit of mine, something akin to an instinct, not to make a glue-line where it can be avoided. It is certainly quicker to slice the plane body into three sections, cut the cavity in the middle section and glue everything together again. I have done it but do not like it. Instead I use a horizontal mortiser and the following method to cut the throat into my planes.

First I draw the lines showing the cavity location on all four sides of the plane blank. I remove the bulk of the material from the cavity with a 3/8-in. drill. For this purpose I have made an acrylic-plastic shield that I fit to my shop-made horizontal mortiser. The shield sets parallel to the table just 1/8-in. or so above the plane body. I apply tape to the plastic, directly above the drill, which allows me to "see" the position of the drill within the wood. By aligning the taped outline with the pencil marks on the plane body, I can drill the required holes quite accurately and quickly.

To make the plane's throat, I first drill around the edges of the cavity. Then I waste out the rest, always taking care not to drill too deep. I open the mouth of the plane carefully from the sole with a 3/8-in. drill. Then I clean up the cavity with a chisel and level the plane-iron bed with a float.

—Stefan During, Texel, Holland

Quick tip: Our shaper used to be our main bottleneck, with setup time taking twice as long as cutting time. To solve the backup, I bought six ball bearings—from 3/4-in. to 3 1/2-in.—all with a center hole to fit the arbor. The bearings control depth of cut as does a router bit's pilot bearing. By combining the pilot bearings with various cutters and collars, we can now quickly set up for many cuts that used to require interminable fiddling around. —Craig L. Graybar, West Allis, Wis.

Truing muslin polishing wheels

To true the perimeter of stitched-muslin polishing wheels after they get raggedy and misshapen, chuck a Surform sanding disc in your electric drill. With both the sanding disc and the wheel running, carefully bring the disc into contact with the

wheel. The Surform's rotation should be opposite to that of the muslin wheel. Apply the Surform in short bursts so that it doesn't overheat. —W.H. Fowler, Anchorage, Alaska

Jigsaw vacuum attachment

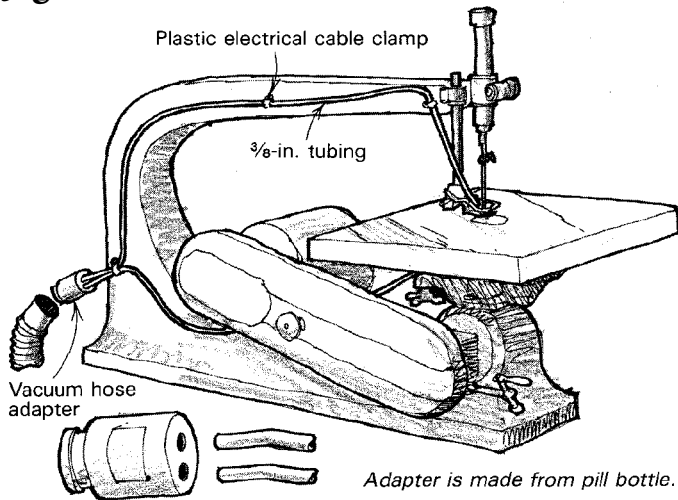

In past Methods of Work columns I have noticed a couple of ideas for blowing sawdust away from the cutting line on scroll saws or jigsaws. These methods seem to me to be contrary to the usual thinking about dust collection. On other machines dust is vacuumed, not blown around the shop to light in eyes, noses and motor bearings.

I've solved this problem with a few feet of 3/8 in. flexible plastic tubing, plastic electrical cable clamps, an empty plastic aspirin bottle and my shop vacuum. The aspirin bottle just happens to fit the adapter on the end of my vacuum hose. I attached the tubing to the aspirin bottle with clear silicone sealer. You can form the end of the plastic tubing to point it right where it is needed: Dip the tubing in boiling water for a few seconds and hold it in the shape you want while it cools. This simple arrangement works quite effectively to pull dust away from the work and out of my environment. I plug the saw and vacuum into a foot switch so they operate together.

—R. J. West, Kansas City, Mo.

Shaping beams with a router

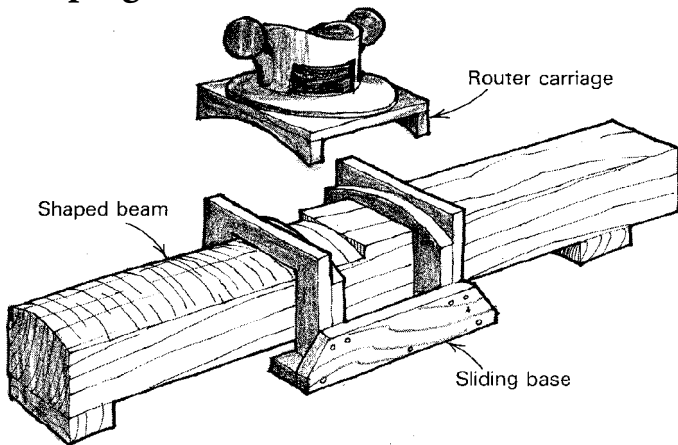

Four years ago my eight-year-old daughter, an aspiring gymnast, pleaded for a balance beam of her own to practice on. Her request required me to find a way to shape the sides of a 16-ft. beam into uniform arcs, so that the finished beam would be as near regulation size and shape as possible. My solution was a sliding jig that guided a router with a 1-in. bit. The jig

consists of two parts: the sliding base and the router carriage. Curved rails on these parts guide the router in the proper arc. In laying out the jig you must increase the radius of the curved rails by the amount that the bit protrudes from the router base so that the end of the bit follows the desired finished radius. I recommend you lay out the plan of the jig full-size to verify the correct juxtaposition of beam, cutter and jig.

To use the device, start at one end of the beam and arc the router to and fro as you slide the jig along. The router will let you know how much of a bite to take. The process is slow but accurate. To finish up the very ends of the beam, where the bit can't reach, you can rig up some additional bearing surface or simply use a chisel and plane. —Burt Babkes, Eugene, Ore.

Quick tip: When stripping furniture, instead of spending a fortune on sandpaper and steel wool, fold up some old aluminum window screen. —Richard Tolzman, Excelsior, Minn.

Shop-built doweling machine

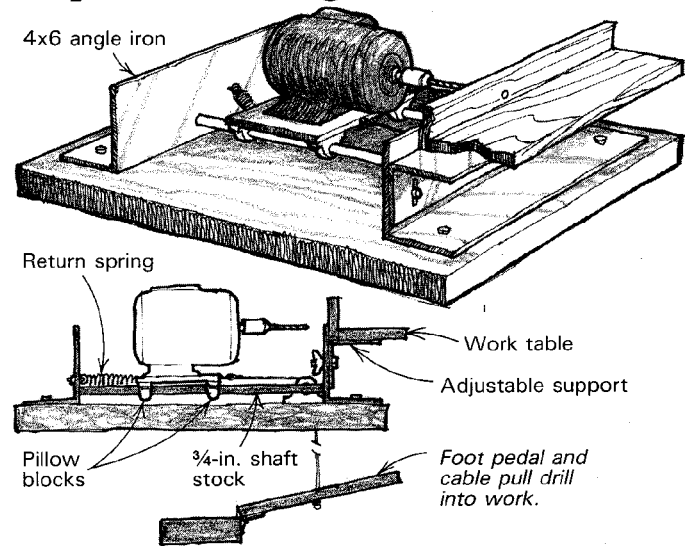

In my one-man cabinet shop I used a doweling jig to drill holes for dowel joints in cabinet door frames and the like. Although I found this procedure too slow, when I went shopping for horizontal boring machines I found them too expensive. Basing my design on a few sketches I made on my shopping trip, I built the machine shown above for about \$260, which included \$120 of machine shop expense.

The machine consists of two opposed 4x6 steel angle iron sections bridged by two 3/4-in.-dia. steel shaft-stock rails. Boring is accomplished by a 1/2-HP, 1725-RPM motor that slides down the rails on pillow blocks. The sliding action is provided by a low-tech (but effective) pulley, cable and foot-pedal arrangement. A strong coil spring attached to the back of the motor base pulls the motor back out of the hole when the foot-pedal is released. The work table is adjustable vertically, as shown in the sketch, to accommodate different stock thicknesses.

Since the rails must be perfectly parallel I had a machine shop drill the critical rail holes in the angle iron pieces. The machine shop also threaded the rail ends and reworked the motor shaft to accept a chuck.

—Hjardar Bruun, Ferndale, Wash

Methods of Work buys readers' tips, jigs and tricks. Send details, sketches (we'll redraw them) and photos to Methods, Fine Woodworking, Box 355, Newtown, Conn. 06470. We can acknowledge contributions only when the final decision has been made. We'll return those that include an SASE.

Hidden floating-dowel joint

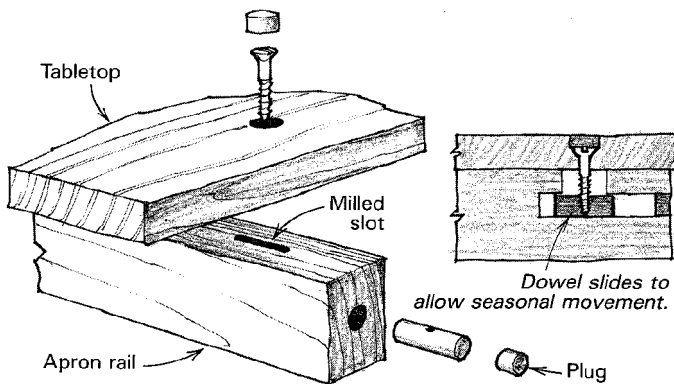

This hidden joint discretely accommodates the seasonal movement of a solid-wood tabletop in relation to its apron. It could also be used to fasten a seat to its rails or a shelf to its brackets. Start by drilling a hole lengthways into the end of the apron. Then mill a narrow slot all the way down into the hole cavity, as shown. Insert a short dowel that's loose enough to slide easily into the hole, and center it under the slot. Plug the hole in the apron and finish as desired.

To fasten the tabletop to the apron, drive a countersunk and plugged screw through the top, through the milled slot and into the dowel. If you don't want screw plugs to show on the top, the construction of the joint can be reversed with the dowel installed in the top and the screw driven through the apron from below.

—Sandor Nagyszalanczy, Santa Cruz, Calif.

Quick tip: Even if your shop doesn't have a place to wash your hands, you can still avoid leaving oily fingerprints on light woods if you "wash" your hands in a box of fine sawdust from time to time. It works just like sawdust on oil spots in your garage.

—Jeff Gyving, Point Arena, Calif.

Drawing large shallow curves

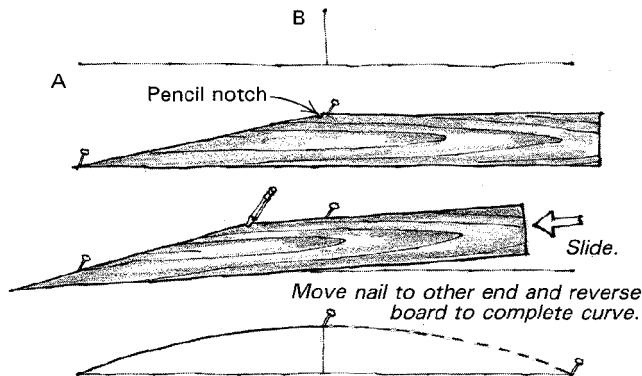

When I was a boatbuilder we used this shallow-curve drawing method to set out the deck beams of yachts. The trick works for drawing any such curve with a known rise and run.

You'll need two nails and a "spile board." Cut the spile board as wide as the curve's rise and taper the board on one end with the length of the taper equal to the curve's run. Notch the board at the location shown to catch a pencil point.

Drive one nail at point A and another at point B. With a pencil in the notch and the spile board positioned as shown in the sketch, slide the board toward the nail at A to draw the curve. Nail A can be removed and driven in the other end to complete the curve. In our situation the method was used to make a template from which all the shorter beams and carlings could be marked.

—Ernie Ives, Sproughton, Ipswich, Eng.

Clearing jigsaw sawdust with a flit gun

I've seen a couple of methods recently for clearing jigsaw sawdust with a hair dryer and with a vacuum. The "flit gun" method I have been using for 15 years does the job very effectively. The device doesn't consume much energy, is practically noiseless and produces short puffs of air to clear only the immediate area on the workpiece.

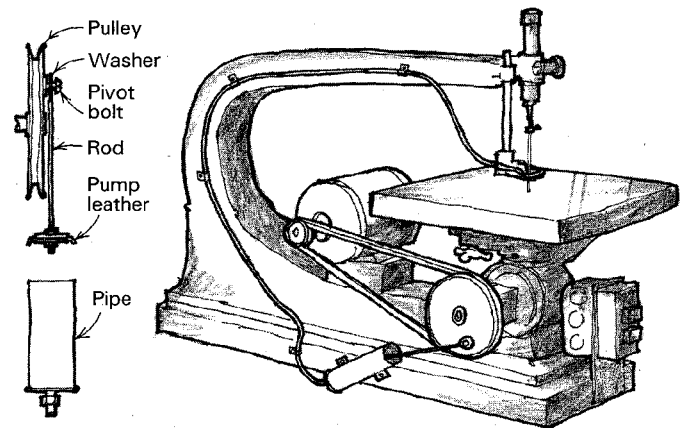

To build the flit gun, start with a length of 1½-in. brass sink drain pipe. I soldered a brass plate with a compression fitting to one end of the pipe, as shown in the sketch, but a wooden plug epoxied into the end of the pipe would work just as well. Now make up a plunger with a pump-leather on one end and a washer for a crank pivot on the other. Locate a crank bolt about 2-in. from the center of the jigsaw's pulley. The gun's cylinder can be fastened at any convenient location on the jigsaw, either horizontally or vertically. Run plastic tubing from the end of the flit gun to a spot above the worktable. Turn on the jigsaw and let the flit gun fire away at the sawdust.

—Edward J. Daly, Wyckoff, N.J.

Quick tip: A plastic squeeze bottle with a cone-shaped top and small opening, like those used for mustard and ketchup, gives a strong, well directed shot of air for blowing dust out of hard-to-reach places.

—Denny Kemp, Dallas, Tex.

Depth-stop for backsaw

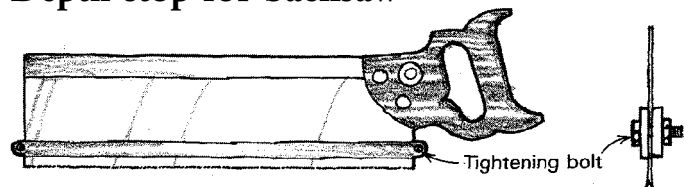

This adjustable depth-stop for the backsaw aids in cutting accurate dados, rabbets, and half-lap joints. The idea is adapted from an antique saw I have. The stop is a couple of lengths of ¾-in.-thick steel bar stock fitted with bolts on each end to tighten the stop on the blade at the desired setting. Alternatively, I suspect that the two bars could be made of wood if they were crowned slightly in the middle to clamp the entire blade length when tightened. If I have only a few dados to make I nearly always use this saw. It is easier and quicker than setting up the tablesaw with dado blades.

—Bert Whitchurch, Hemet, Calif.

Lubricating tablesaw adjustment gears

To lubricate tight, binding adjusting gears in the tablesaw, first vacuum and then brush the mechanism with a nylon parts-cleaning brush. Then spray the gears with a chain lube such as

Whitmore's Open Chain Lubricant or PJ-1 Heavy Duty Chain Lube. These slippery-film lubricants are well adapted to the dusty environment under the saw's table. An occasional application will provide continued smooth adjustment action, even when cutting abrasive materials like fiberboard or Masonite.

—John Grew-Sheridan, San Francisco, Calif.

Third hand for spindle copying

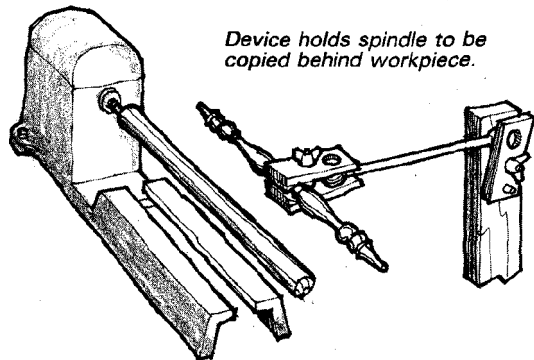

Device holds spindle to be copied behind workpiece.

This simple device, by holding a master spindle in full view directly behind the workpiece, eliminates much of the tedious measuring and template making that's usually required to duplicate a turned spindle. With the master copy registered near the work you can accurately judge lengths, critical layout cuts and even diameters and shapes by eye.

To make the device, turn a foot-long dowel "arm" with 1-in. balls on each end. Make up two pinch-blocks, as shown in the sketch, to lock the arm at any setting needed. The rear pinch-block may be attached to the lathe bed or fixed to a floor stand behind the lathe. —A. D. Goode, Sapphire, N.S.W., Australia

Quick tip: I added a foot-treadle to my drill press by wrapping some plastic-covered cable around the quill and hooking it up with some other odds and ends from the hardware store. Now I can lower and raise the quill without taking one hand off the work. —Harold L. Wilcox, Binghamton, N. Y.

Strengthening curved frame members

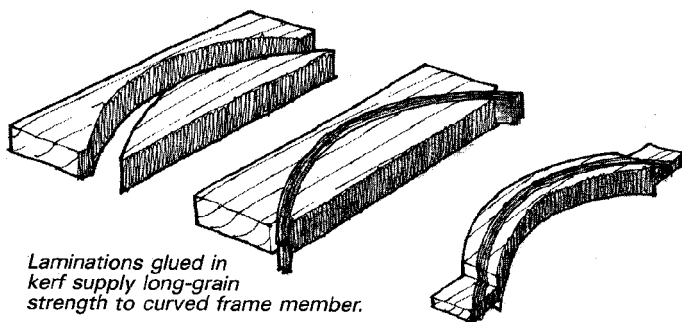

Laminations glued in kerf supply long-grain strength to curved frame member.

Curved frame members can look attractive. But when curves are cut from solid wood they may be structurally unsound, because the long grain is severed. Fully laminating the piece adds the necessary strength but requires special forms and much fussing. In addition, the laminated workpieces are difficult to machine further. Here's a procedure that solves these problems. It adds strength where needed, no forms are required, and the resulting workpiece is easy to machine.

To make the frame member, first saw the workpiece blank into two pieces, following the midline of the curve. Using three or four $\frac{1}{16}$ -in.-thick plys, glue up a sandwich as shown. When the glue sets, trim off the excess laminations, cut the member to shape and machine. —Jim Fawcett, Rosendale, N. Y.

Self-made mortising template

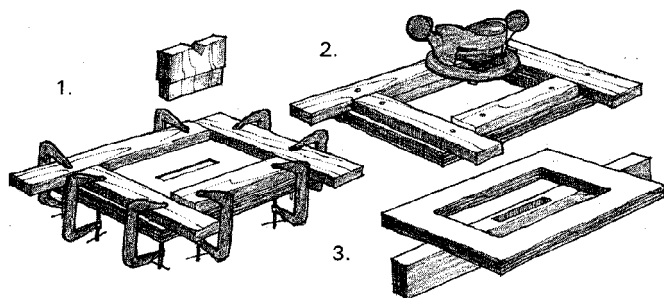

This procedure for making a router template is quite accurate because in the early stages the template uses itself for the set-up and quality control. First lay out the mortise dimensions on the template stock. Now, with the router and bit you intend to use for the actual mortising, line up the cutting circle of the bit with one wall of the mortise. Clamp a strip parallel to the mortise side so it butts against the router base, thus defining that mortise wall. Repeat the process on the other three sides.

Now, as a test, rout a shallow mortise in the template stock. If the tenon does not fit, move and reclamp the guide boards. If the mortise is slightly oversized, you can add shims. Then cut another test mortise, a little deeper, and repeat until you have the fit you want. Next screw the guide strips in position, countersink the screw heads and remove the clamps.

To finish the template, cut out the center of the blank and trim the edges flush with a router and a flush-cutting bit as shown in step 2, then remove the guide strips.

—Patrick Warner, Escondido, Calif.

Quick tip: To form ferrules of any size on shopmade handles for files or carving tools, wrap some copper wire around and coat with solder. —Donald E. Wigfield, Moneta, Va.

Lathe-based sharpening wheel

Some time ago I decided to reshape my lathe skew chisels to Mike Darlow's specifications (FWW #36). I devised this simple-to-make grinding wheel that uses the lathe itself to produce the 8-in.-dia. hollow grind Darlow recommends.

First, glue two 9-in.-dia., $\frac{3}{4}$ -in.-thick plywood discs together and permanently screw them to a faceplate. Mount this on the lathe and turn the edge and face true.

Laminate a piece of $\frac{1}{8}$ -in. acrylic plastic to the face and smear a $\frac{1}{8}$ -in.-thick coat of epoxy around the full edge. When the epoxy is hard, turn the edge until it is true and flat, leaving as

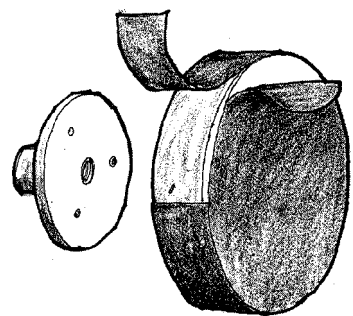

much epoxy as possible. True the face of the disc if needed. Using sanding-disc adhesive, glue coarse emery cloth to the face and edge of the disc to complete the grinding wheel.

To use the wheel, set the lathe at its slowest speed and rest the tool to be sharpened on the tool rest. Use the edge of the wheel for a hollow grind and the face of the wheel for a flat grind. —Dwight G. Gorrell, Centerville, Kan.

Methods of Work buys readers' tips, jigs and tricks. Send details, sketches (we'll redraw them) and photos to *Methods*, Fine Woodworking, Box 355, Newtown, Conn. 06470. We can acknowledge contributions only when the final decision has been made. We'll return those that include an SASE.

Two more sawhorses

Here's a sawhorse with no metal parts to mar your work. These horses stack neatly, and they can also be knocked apart easily for storage or transport. The plywood legs are 8 in. wide at the top, though 6 in. will work if you want to cut down on weight. The only caution is that the sliding joints must be cut tight enough so that they must be driven with a hammer, or the horse will wobble. This construction is much stronger than it looks at first glance—I've put one sawhorse through the teenage student torture-test in my shop class, where it survives unbroken.

—Mark Blieske, Winnipeg, Man.

Blieske's sawhorse

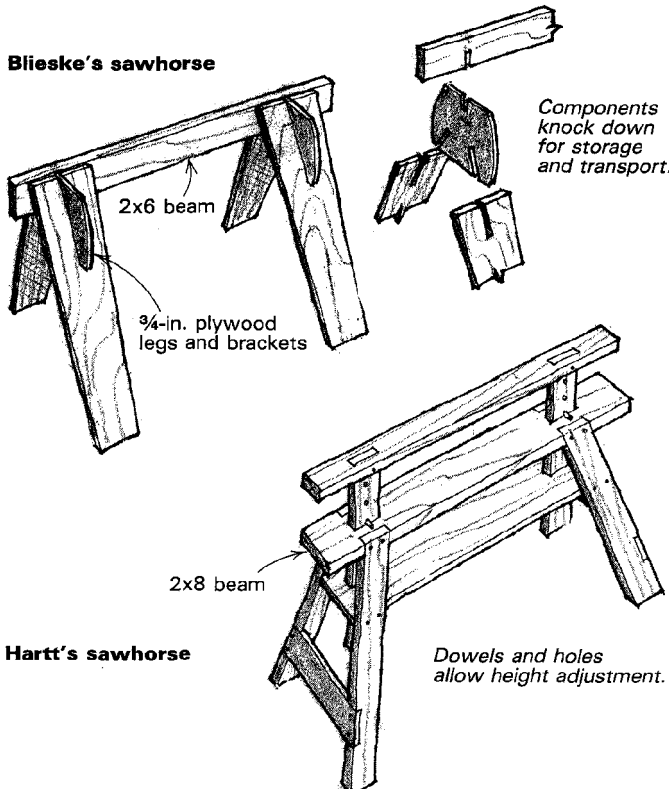

Hartt's sawhorse

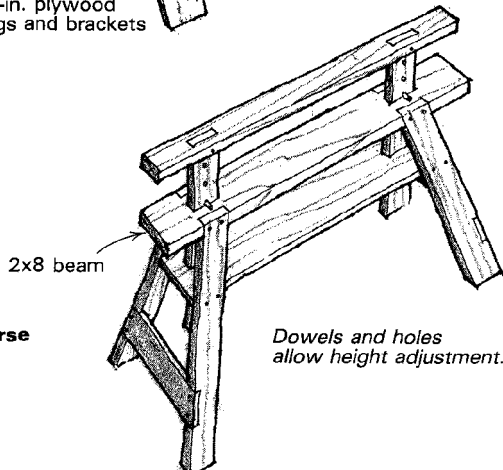

The adjustable-horse design shown above was originally published as a project in a 1958 *Deltagram*. I have put together several sets of these horses and find them to be valuable additions to any shop. With the extension down or removed, it is a sturdy saw-horse. With the extensions raised, two horses and a sheet of plywood make a handy layout table. The extensions can also be used to support long stock or plywood sheets when ripping on the table saw.

—Grover Hartt Jr., Dallas, Tex.

Quick tip: For those interested in trying tool making and heat-treatment procedures, a good (and inexpensive) source of high-carbon steel is the ordinary masonry nail, which can be shaped into a variety of small veiners, gouges, chisels, punches and embossing tools.

—Thomas Hamel, Houston, Tex.

Raised panels on the jointer

You can produce panels with beautiful long-tapered bevels on your jointer, provided it has rabbeting capability. Build an outboard table from 3/4-in. plywood about 12 in. wide and as long as your jointer. Mount the table to your jointer or jointer stand so that the outside edge may be raised or lowered to produce the desired angle. The inboard edge of the table should be about 1/4 in. from the jointer's cutterhead.

Clamp a strip of wood to the jointer's fence flush with the jointer's bed to prevent the thin edge of the panel from sliding under. Three interrelated factors determine the shape of the

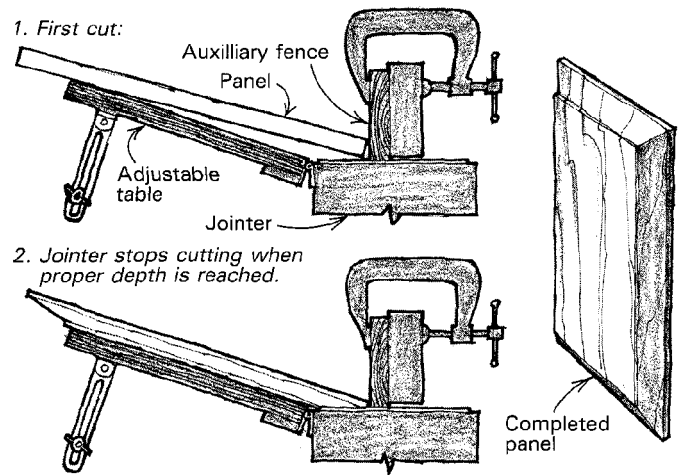

bevel. The depth of the shoulder on the panel is determined by the height at which you set the infeed table. The distance from the fence to the end of the cutterhead determines the width of the bevel. The thickness of the edge of the panel is determined by the angle of the outboard table, the width of the bevel and the depth of the shoulder.

When the setup is right, turn on the jointer and slide the panel over the cutterhead. Since the shoulder will ride on the jointer's infeed table when the proper depth is reached, you simply continue making passes until the jointer's knives stop cutting. Cut the two end-grain sides of the panel first so that tearout will be removed when the other two sides are cut.

—Norris S. White, Sellersville, Pa.

Quick tip: For grinding and honing spokeshave blades or other short, hard-to-hold irons, make an extension holder by sandwiching the blade between the cap iron and the iron of a full-size plane.

—Stephen Cohen, Woodstock, N. Y.

Two storage containers



Recently Wilson began packaging tennis balls in unbreakable clear plastic containers with removable plastic lids. These containers make excellent storage bins for nails, screws, and the like. If you're not a tennis player, just scrounge the trash cans at your nearest tennis court or ask a local club pro to save some for you.

—R.B. Hurley, Williamsburg, Va.

Coffee cans with plastic lids are ideal storage containers for nails, etc., except for one problem—you can't tell what's inside. To remedy, fold the lid slightly and poke a nail in one side and out the other (like a safety pin in a baby's diaper) to leave a sample on the lid readily identifying the contents.

—Jeris Chamey, Ponka City, Okla.

Quick tip: Film canisters (35mm) are handy containers for small tacks, brads and the like. You can stick a sample through the lid. A block of wood with 1/4-in. holes will keep the collection in order.

—John Rocanova, Bronx, N. Y.

Salvaging boards with loose knots

To salvage a board with an interesting but loose knot, fill the space around the knot with acrylic casting resin (available at hobby shops). First put tape on the back side of the knot and,

with the taped side down, pour acrylic into the knot until it mounds up on top. After the resin has cured, you can scrape or sand it flush. Any scratches will disappear under a coat of lacquer or varnish.

—David W. Worden, Pontiac, Mich.

Ferrule tool

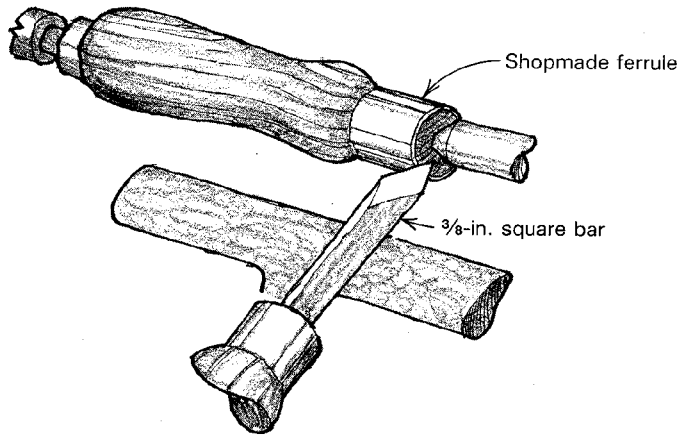

In *FWW#45*, James Dupler described a lathe tool for turning beads. It reminded me of the similar tool I use for truing the ends of shopmade copper or brass ferrules.

Make the tool from a short length of $\frac{3}{8}$ -in.-sq. tool steel—the blade should project no more than 2 in. from the handle to reduce vibration. Grind the end to a diamond-shaped face.

To use the tool, first turn a handle on the lathe. Remove the handle and drive a short section of copper tubing onto the end. Remount the handle, and with the toolrest close, bring the tool to the ferrule with the diamond face up. Roll the tool until the edge cuts, then proceed to level and round the end of the tubing.

—P. W. Blandford, Stratford-on-Avon, Eng.

Quick tip: A nubby rubber doormat makes a great surface for holding small parts when power-sanding—the nubs grip like a thousand fingers.

—Yvonne Ashmore, Grass Valley, Calif.

Flip-down wheels

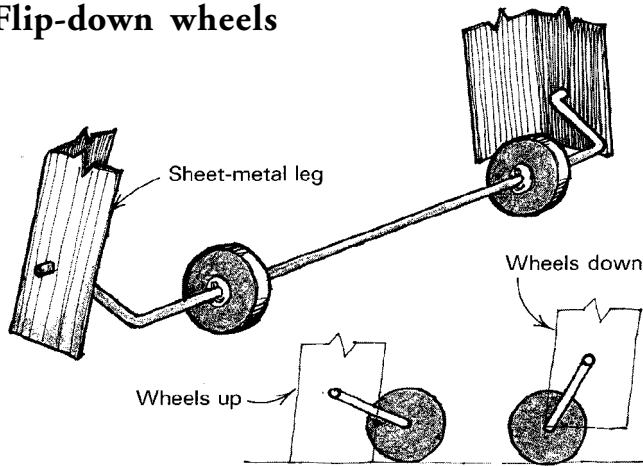

This simple flip-down axle fits tool stands with bent sheet-metal legs. First slide two wheels on a $\frac{3}{8}$ -in. steel rod, adding washers and cotter pins to keep the wheels in position. Bend the rod to a wide U-shape, as shown, and install the axle through holes in two legs. The holes should be located so that when you lift up the end of the stand and flip down the axle with your foot the axle will bear against the inside bend of the leg, effectively locking itself in position.

—Jeff Lormans, Dunedin, New Zealand

Homemade wood-branding iron

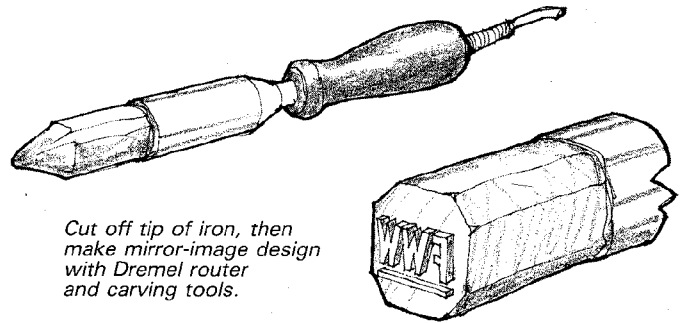

Cut off tip of iron, then make mirror-image design with Dremel router and carving tools.

If you have always wanted one of those fancy branding irons to mark your projects, but felt they were too expensive, here's how to make one in your shop for next to nothing. First, scour the local flea markets to obtain a large electric soldering iron. Some of the older ones have copper tips a full inch across. The iron must work, but the condition of the tip is not important.

Cut about half the tip off to leave a large flat across the end of the iron. File this smooth. Trace your name or logo on the copper face, remembering that the design must be the mirror image of what you want to stamp on your projects. Rout around the letters to a depth of $\frac{1}{8}$ in. with a Dremel tool, then use a small chisel or your woodcarving tools to finish up the design and add crisp edges. Copper is soft and will pare away easily—like carving lilac end grain.

If you can't locate an old soldering iron of sufficient size to handle your design, an alternative approach is to flatten the tip as above, but carve the design on a separate chunk of solid copper. Then use a torch and high-temperature silver solder to attach the plate to the iron.

To use the branding iron just let it heat up and press the copper against the wood. Presto! Your name is permanently charred in wood.

—Wayne Spicer, Memramcook, N.B.

Quick tip: After much use, the tailstock of a Pony clamp will tend to slip because the edges of the four steel plates have become dull. To remedy this, reverse the plates so that a new edge is presented to the pipe.

—Tom Ayers, Dover, Ohio

Hole-spacing tool

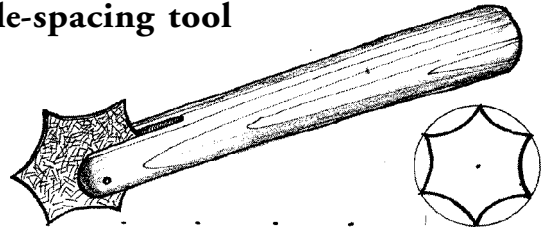

With this adaptation of a leather-stitcher's spacing tool you can quickly lay out a row of evenly spaced holes with surprising accuracy. First set a compass to the distance desired between holes and scribe a circle on 14-ga. sheet metal. Use the same compass setting to scribe six equidistant points around the circumference of the circle. Draw arcs between the points of the hexagon to create the six-pointed star shape shown in the sketch. Cut the star from the sheet metal, sharpen the points and mount the tool in a slotted handle using a nail for an axle.

—Sandor Nagyszalanczy, Santa Cruz, Calif.

Methods of Work buys readers' tips, jigs and tricks. Send details, sketches (we'll redraw them) and photos to *Methods*, Fine Woodworking, Box 355, Newtown, Conn. 06470. We can acknowledge contributions only when the final decision has been made. We'll return those that include an SASE.

Homebuilt sawdust-burning shop heater

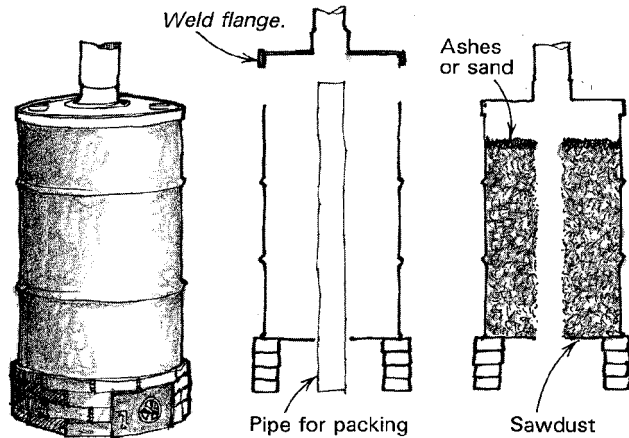

If you've ever looked at the huge pile of sawdust and planer shavings that even a small shop produces and wished you could burn it for heat, here is an inexpensive but efficient solution based on an ordinary 55-gal. steel drum.

Construction of the stove is relatively simple. Because you have to open up the stove every day for loading, what you're after is a removable lid that can be easily assembled or disassembled from the stovepipe. First cut the top off the drum right below the lip. Fashion a retainer ring of strap iron and weld it around the top to produce a removable lid, as shown in the sketch. Cut a hole in the center of the lid and attach a 6-in. stovepipe adapter flange to the middle of the top. You will also need to cut a 4-in. hole in the center of the bottom of the drum for the fuel packing pipe, explained below. Set the stove up on an airtight ring of firebricks (use fireclay for mortar) laid right on your cement floor. If possible, add a scrounged door from an old woodstove to regulate air and to provide an access for cleaning out ashes—this was an improvement we added the second year; the first year we blocked off the air with the lid of a 5-gal. paint can.

How this stove works is truly amazing. The secret is leaving a chimney hole right through the fuel after it is packed. To do this you just remove the stove's lid and insert the "fuel packing form" (a length of 3½-in. plastic sewer pipe) down through the hole in the bottom so that it sticks up out of the top of the drum. Now load the drum with planer chips, sawdust, floor sweepings—anything that will burn. Pack it down tightly around the plastic pipe until the drum is full to about 5 in. or 10 in. from the top. Sprinkle the top of the packed sawdust with sand or ashes so it won't burn anywhere but in the middle. Pull the plastic pipe out of the packed fuel, replace the lid and light a small fire underneath the barrel.

A full drum will heat our 3,500-sq.-ft. North Carolina shop for eight hours with no attention. Since we are burning kiln-dried wood chips, the flue gasses are clean and combustion is complete. When the stove is going strong no smoke comes from our chimney—only clear, hot gasses.

—Paul G. Caron, Cashiers, N.C.

Quick tip: To work glue into a crack, try using an auto feeler gauge as a spatula.

—Charles Moyer, Peninsula, Ohio

Plug locates nut

Embedded nuts are a convenient Joinery technique for beds, trestle tables and other projects that may have to be knocked down for moving or storage. The method shown here, in which a square nut is held in place by a slotted dowel plug, has some nice features and can be adapted to a variety of sizes. My usual combination is a standard bedbolt and nut (available

from most period hardware suppliers) with a 1-in.-dia. dowel. For clarity, the drawing omits the stub-tenon on the rail and the mortise in the post, which, if you use just one bolt, are necessary to keep the joint from twisting.

I slot the end of the dowel by running it over a ¾-in. dado blade in the tablesaw. I've devised holding and indexing jigs that attach to my miter gauge for this job because I make about a year's worth of plugs at one time. For just one or two projects, you could use a regular blade and make two or three side-by-side passes until the slots are wide enough to accommodate the bolt and nut. It would be a good idea to use the end of a 2x4 scrap as a push block to keep the dowel vertical and prevent it from kicking back. The depth of the slot should allow the end of the inserted nut to be just flush with the end of the dowel. Then cut the plug off a little longer than necessary—as it will be smoothed flush after it is glued in place in the rail—and continue cutting plugs until the dowel gets too short to handle safely.

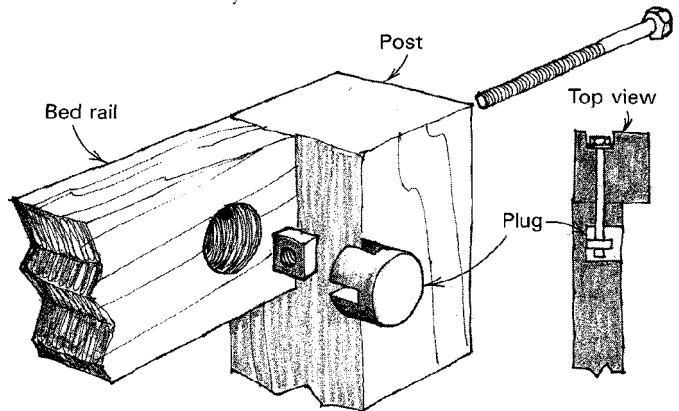

The plug gives a nice inside finish to the rail, stops the nut from turning, and prevents the nut's corners from cutting into the rail, which would eventually loosen the joint.

Alignment of the holes is critical. One trick is to drill the bolt-holes in the bed's posts on the drill press, to ensure that they are centered and straight, then, with the joint assembled, use an electric drill (with the holes in the bedposts as pilots) to continue the bolt-hole into the rail. Size the depth of the dowel-hole in the rail so that the bolt engages the nut smoothly. Test the alignment before gluing the dowel and nut in place; if you are a little off, you can enlarge the bolt-hole somewhat without weakening the joint much.

—Christian Becksvoort, New Gloucester, Me.

Consistent dados on the tablesaw

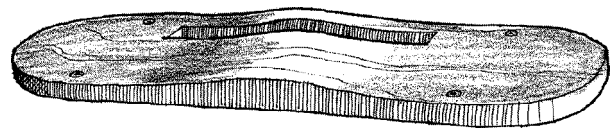

The secret of this simple wooden tablesaw insert is the hump in the middle. Because the work will touch only at the high point of the hump, dados and grooves will be consistently the same depth regardless of slight waves and warps in the wood.

—David Ward, Loveland, Colo.

Sheet-metal sanding shield

Whenever I sand panel frames or other woodwork where it is difficult to avoid getting cross-grain scratches on adjacent surfaces, I use a very thin piece of sheet metal in much the same way as a draftsman uses an erasure shield. I hold or clamp the shield over the section I want to protect and then just sand right up to and over it. In a similar way I can drill or cut out

shapes from the center of a sheet that allow a tenon or plug, for example, to stick through and be sanded without affecting adjacent areas. The sheet metal I use is some 28-gauge stainless steel that I found at a surplus and salvage store. It's thin, less than $\frac{1}{64}$ -in., yet can withstand occasional belt sanding.

—Sandor Nagyszalanczy, Santa Cruz, Calif.

Quick tip: Paraffin wax makes a good finish for wooden toys. Warm the wood, then rub on paraffin that's been melted in a double-boiler (melt it carefully—paraffin is extremely flammable). The finish is safe, non-staining and can be polished to a dull luster.

—Keith Hacker, Scandia, Minn.

Compression rings for split turnings

Drive rings on blank before turning.

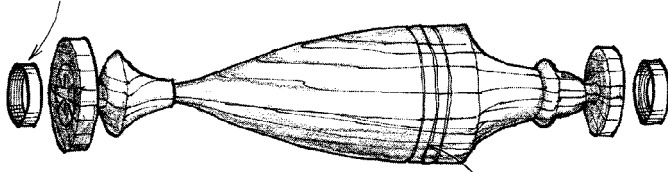

After turning, remove rings and split turning apart at paper joint.

Half-round turned columns and finials make attractive decorative elements on clocks and chests. These are usually made by gluing up a laminated turning blank with paper between the pieces. After turning, the halves are separated by inserting a thin knife into the paper joint.

One drawback with this technique is that the lathe centers can wedge apart the weak paper joint when the blank is tightened on the lathe. To avoid the problem I use compression rings, driven in each end of the workpiece, to hold it together during turning. I make the rings from thin-wall tubing (conduit) by sharpening one end with a file, then I drive the rings about $\frac{1}{8}$ in. into each end of the turning.

—Norman Brooks, Greenville, Penn.

Quick tip: When sharpening on the grinder, I chill my tools in ice-water. Heat builds up more slowly in the cold metal, making the whole operation much more relaxed, and therefore more accurate.

—Milton B. Ketter, El Sobrante, Calif.

Wall-hung right-angle marker

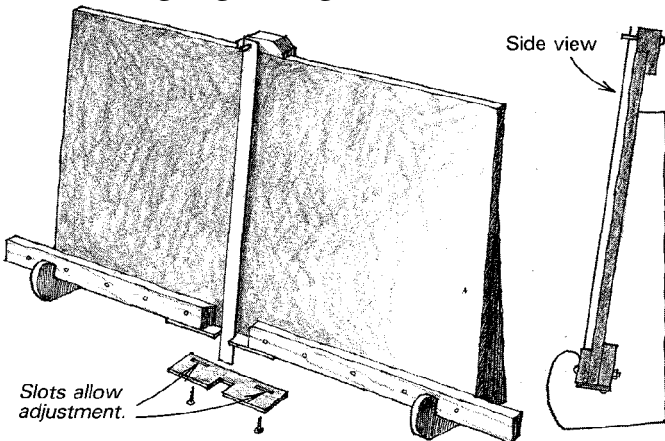

In my model making/prototype shop much of our layout work requires quick, accurate right-angle scribe marks on thin materials ($\frac{1}{16}$ in. to $\frac{1}{2}$ in.). Frustrated with inaccurate and easy-to-knock-out-of-square framing squares, we built this wall-hung right-angle scribing unit that can accommodate materials as

wide as 34 in. The main part of the unit is a 3-ft.-tall, 4-ft.-wide panel of cabinet-grade particleboard fitted with a two-piece 1x2 hardwood ledge screwed to the bottom edge. Other components include a stainless steel ruler that hangs from a pin at the top and is indexed by a notched plate at the bottom.

We turned a threaded rod to make the ruler-pin; it must fit the hole in the ruler exactly. At the bottom of the notch-plate assembly is the key to the unit's accuracy, a $\frac{1}{8}$ -in.-thick steel plate about 3 in. wide and 6 in. long. File a notch in the plate carefully, so that it is just as wide as the ruler and no more. Screw the notch-plate to the bottom of the assembly through slotted holes so that the ruler-notch can be adjusted left and right. You can trial-and-error the ruler into perfect square by scribing a line on a test piece then flipping the test piece 180°. If the scribed line on the flipped test piece matches the ruler, it is square. If not, adjust the notch-plate and try again.

The unit works best when it is tilted back from vertical. The drawing shows a quick, if crude, way to support it with two wall brackets. This allows it to be lifted out if there is a need to use it elsewhere.

—Ed Stringham, East Bethany, N.Y.

Quick tip: If you need an unusual-size hole, you can make a regular twist drill bit cut a hole slightly larger than its nominal size by grinding one cutting edge a little longer than the other, so that the point is off-center.

—Michael Turi, Arcata, Calif.

Two non-slip push blocks

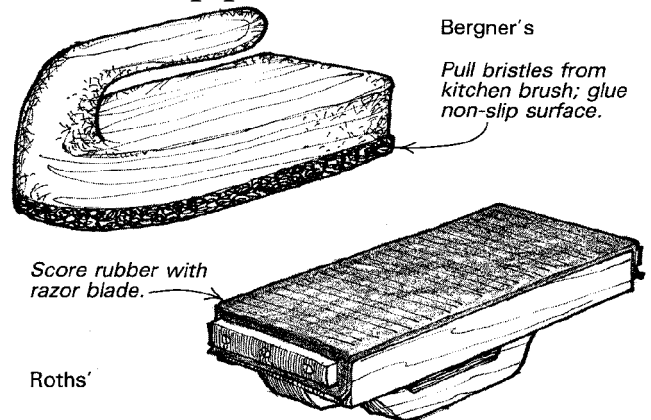

Along with my new jointer I wanted to purchase a set of push blocks—the kind with a molded plastic handle and $\frac{1}{4}$ -in.-thick black foam material on the bottom. But when I found the set was priced at \$16, I promptly left the store without them.

The next day I happened to bump into a kitchen brush sale and realized that, except for the bristles on the bottom, the \$55 brushes were virtually identical to the expensive push blocks. So I bought a pair, pulled out the bristles with pliers and glued a Scotch-Brite pad to the bottom for a non-slip surface. Felt and sandpaper or dense foam could have been used equally well. The total project took 30 minutes and cost \$2.50 to complete.

—Mitch Bergner, St. Louis Park, Minn.

When I needed a non-slip, non-mar push block for pushing panels through the shaper I borrowed an idea from boat shoes. I attached an innertube scrap to the bottom of a shopmade block and scored the tube with a razor blade about $\frac{1}{32}$ -in. deep every $\frac{1}{4}$ in. or so. The slices open up slightly under pressure and really grab the wood.

—Mike Roths, Vinton, Iowa

Melting shellac sticks with a hot-glue gun

The experts say that melting a shellac stick with a hot knife is the best way to fill imperfections (see *FWW* #34). But when I tried, my lack of expertise with a hot knife produced an awful,

uncontrollable mess. So I retrieved my hot-glue gun from the box labeled *things I wish I had never bought* and discovered, to my delight, that the glue gun is an excellent shellac stick applicator. It heats the material to just the right temperature and puts it just where I want it. To conserve material, I cut off only the amount of shellac I need and use a short length of dowel as a piston to push the shellac stick through the barrel of the gun.

—Stephen Kelly, Birmingham, Ala.

Self-locking pin chuck

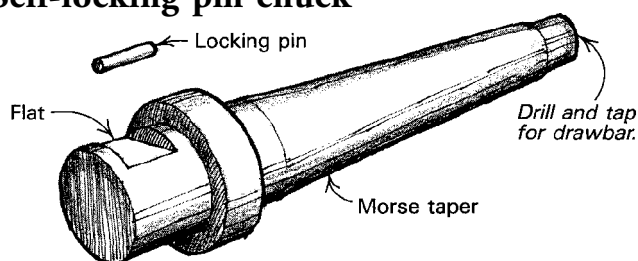

This lathe chuck features an ingenious self-locking mechanism that allows quick and easy mounting and dismounting. It works equally well in both forward and reverse rotation. The chuck is ideal for projects with predrilled, centered holes, such as candlesticks, bud vases, wooden flutes and the like. You simply mount the hole over the end of the chuck to turn the profile.

To make the chuck, start with a length of mild steel bar. Turn a Morse taper on the tail of the chuck to fit your headstock. Then turn the head of the chuck to fit a predrilled hole in your turning blank— $\frac{3}{4}$ in. for example. Now file a flat spot on the head, as shown in the sketch. The depth of the flat should be just a bit greater than the diameter of the locking pin. The locking pin is nothing more than a piece of nail almost as long as the flat.

To use the chuck, first drill a hole the same size and depth as the head of the chuck in your workpiece. With the locking pin centered in the flat, slip the workpiece on the chuck and rotate the work until the pin wedges and locks the workpiece in place. The chuck will lock in either direction—be sure you lock the work opposite the way your lathe will be turning. If you don't, tool pressure will unlock the chuck while you work.

—John G. Martin, Cumberland, Me.

Shopmade screw-pilot drill

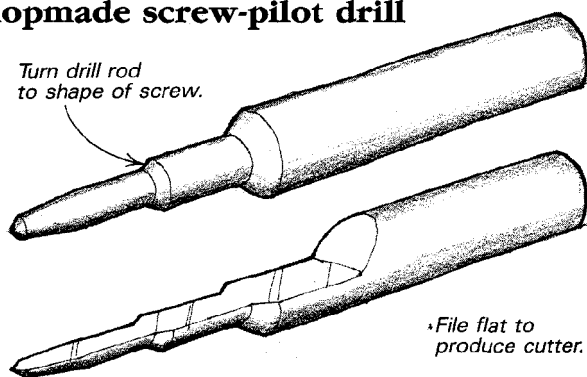

Most woodworkers are familiar with the special bits that drill a combined pilot hole, counterbore and countersink for screws. They are quite useful when you have a large number of screws to install. Unfortunately, these tools are not available for screws smaller than No. 6 or for other odd sizes and shapes. Here's how to customize your own to fit any screw.

Start with a length of oil-hardening drill rod, available at any industrial distributor or machine shop. Chuck the rod into a

metalturning lathe and machine the end to the desired shape of the screw hole. If you don't have access to a metal lathe, chuck the rod in a drill press, a wood lathe, or even your electric drill and file the rod to shape while it is rotating. Taper the transition points to avoid sharp internal corners that would lead to stress points and possible breakage later.

To produce a cutting edge on the tool, file away exactly half of the cutter using care not to round over the edges. Now harden and temper the cutter with a propane torch (see *FWW* #50 for more on hardening and tempering). Whet the flat side with an oilstone and the cutter is ready to use.

—John G. Martin, Cumberland, Me.

Quick tip: When gluing up tabletops or other projects made from several boards, it is difficult to keep the surfaces aligned. One or another board in the assembly gets contrary, despite the various tricks for keeping things flat. I have found that I have much less trouble if I glue and clamp just two boards, then, when the joint is dry, add the others one at a time until the job is done. It takes longer, but saves a lot of surfacing time in the long run.

—R.B. Rennaker, Kokomo, Ind.

Wooden drawer-pulls

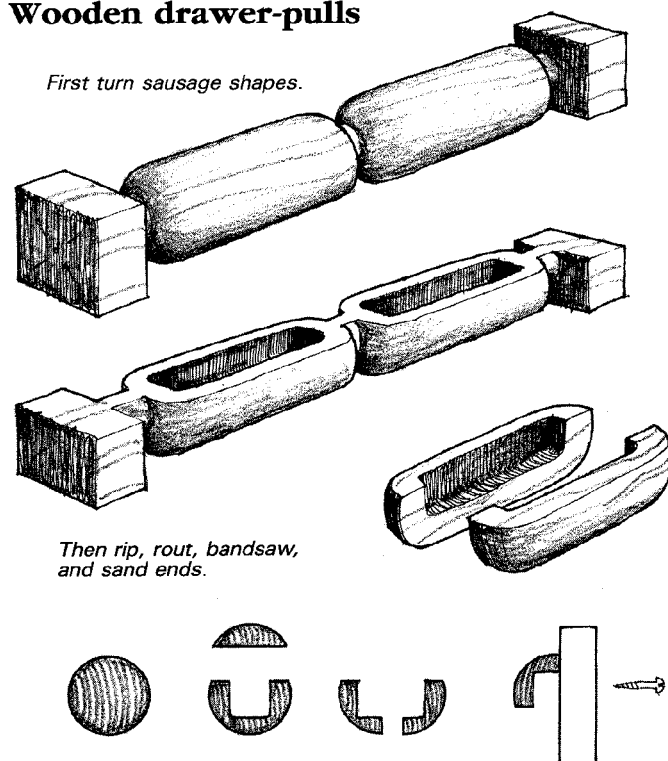

When I couldn't find any solid oak drawer-pulls that I liked, I devised this method to make my own. To make four pulls, mount a 12-in.-long, 2-in.-square blank on your lathe. Turn two $4\frac{1}{4}$ -in.-long, $1\frac{1}{8}$ -in.-dia. sausages. Then rip or plane $\frac{1}{2}$ in. off one side of the sausages to produce a flat face. Rout hollows in the flat with a core-box bit as shown in the sketch. To complete, split the blank lengthwise with a bandsaw, cut the rough pulls apart and finish the rounded ends with a disc sander. Install the pulls with two screws—one each into the solid wood on both ends.

—Gary P. Korneman, St. Joseph, Mo.

Methods of Work buys readers' tips, jigs and tricks. Send details, sketches (we'll redraw them) and photos to *Methods*, Fine Woodworking, Box 355, Newtown, Conn. 06470. We can acknowledge contributions only when the final decision has been made. We'll return those that include an SASE.

Tablesaw rabbet/dado jig

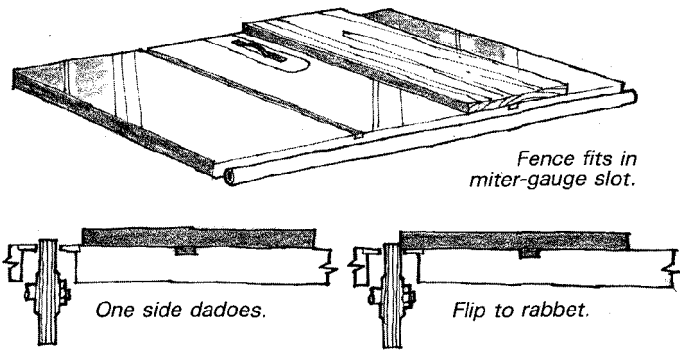

Because the plywood end panels I make for kitchen cabinet jobs are usually worked the same way each time, I found myself setting the rip fence to the same measurements for dados and rabbets time and time again. The simple fixture above solved this problem because it is essentially a pre-measured rip fence that I can use instantly by just popping it into the miter-gauge slot. It's a dual-purpose fixture—I just lift it out of the slot, turn it end-for-end and push it back down into the slot to use the other side. One side cuts dados 2 in. from the edge of the workpiece, the other side cuts $\frac{3}{4}$ -in. rabbets.

The dado fixture worked so well that I made a second variation strictly for rabbeting. One edge is sized to cut $\frac{3}{8}$ -in. rabbets and the other to cut $\frac{1}{4}$ -in. rabbets. I discovered on this second jig that it's best to make the fixture to mount in the right-hand miter-gauge slot if your sawblade slides on the arbor from the right (and vice versa if your blade slides on from the left). If made this way, the fixture can be used with virtually any width dado head in the saw—any excess width in the dado head is covered and doesn't affect the rabbet.

—Don Russell, Auburn, Calif.

Auxiliary lathe tool rest

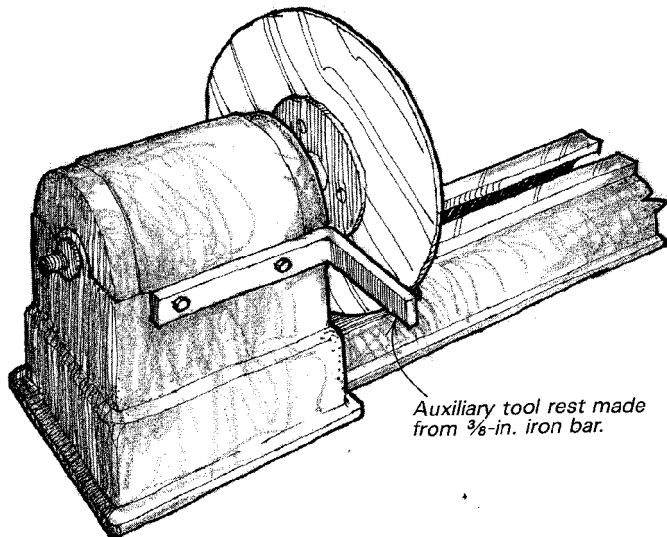

My lathe has a 15-in. capacity over the gap, but when I mount a large bowl or tray, it's impossible to get the tool rest behind the blank to turn the bottom. To provide a tool rest for working the back, I bent a strip of $\frac{3}{8}$ -in.-thick iron to a 90° angle and bolted it to my headstock casting, as shown in the sketch. The tool rest was so useful that I made a set of them bent to different angles to fit different shapes. For safety's sake, remove the tool rest before sanding so your fingers don't get pinched.

—Kevin G. Weir, Brantford, Ont.

Wired tambours

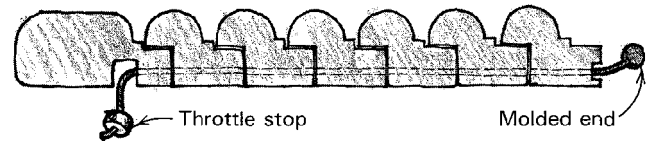

Last year one of the students in my high-school woodworking class made a roll-top desk based on Dale Tucker's wired tambours article (*FWW* #48). As a substitute for the vinyl-coated stainless steel cable Tucker recommended for stringing together the slats, we used ordinary bicycle brake cable, which is easy to find, strong, flexible and comes with a ready-made stop molded onto one end.

To make the tamboured desk top, we first shaped and cut slats with the profile shown. To align the wire holes in each slat we drilled holes in the first slat, clamped it to the benchtop and used it to guide the drill for the other slats. After all the holes were drilled, we threaded the bicycle cable through the slats, pulled it tight and locked it with a throttle stop from the local auto parts store.

—Sam Gardner, Duncan, Ariz.

Quick tip: I live and work wood in a 28-ft. trailer, plus wife and cat, which makes space very precious. Instead of clamping edge-glued projects together with oversized pipe clamps, I've cut my pipes into 1-ft. sections, with both ends threaded. I use pipe couplers to assemble the clamps to whatever length I need for the job—that way I can stash projects along a wall or under a table without awkward lengths of pipe jutting out into my living space.

—Harry Kubeim, Friday Harbor, Wash.

Rubber sanding block

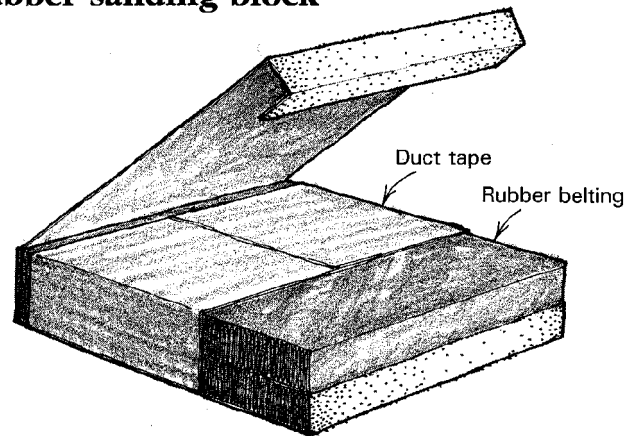

The best solutions are always the simplest. When I needed a firm, yet pliant, sanding block for smoothing a long curve, I put together the block shown here, using two scraps of $\frac{3}{8}$ -in. rubber belting and duct tape. Size the block so that $\frac{1}{2}$ of a standard sheet of sandpaper will wrap around with about $\frac{1}{2}$ in. left over on each end to insert between the two pieces of belting. The block's advantages include two fresh surfaces per filling and less sandpaper waste than commercial rubber sanding blocks. It is cheap and easy to make, and a snap to load. For a good fit, fold the sandpaper around the block and crease the corners before inserting the ends.

—R.G. Sapolich, Johnstown, Penn.

Two-faced sandpaper

Two-faced sandpaper, produced by sticking two pieces of sandpaper back-to-back with double-sided tape, is easier to work with because it doesn't slip under your fingers. The double-faced paper will also stick to a sanding block if the pad area is

covered with flannel cloth. The paper won't slip on the flannel but will pull off easily, so you can change grits almost instantly.
—Joel B. Johnson, Hendersonville, N.C.

Low-cost grinder misting system

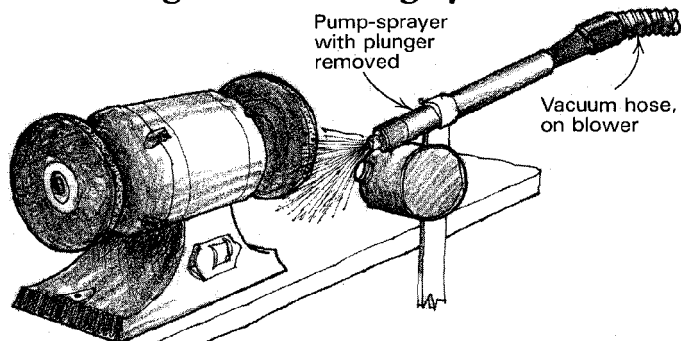

Charles Riordan describes a simple, effective sharpening system (*FWW* #39) that uses a compressed-air-powered misting device to cool the grind. Having neither the money nor the need for an air compressor in my shop, I improvised the misting system shown here. Start with a hand-powered sprayer, known in many locales as a "flit gun," and remove the plunger. Put your shop-vac's hose on the blower side and insert the hose's nozzle in the pump cylinder. Now simply fill the flit gun canister with water, mount the device on a stand near your grinder and turn on the vacuum. Voila! Low-cost, low-tech misting.
—Peter S. Birnbaum, Sebastopol, Calif.

Quick tips When sharpening with waterstones, I avoid making a mess by unrolling an old plastic window shade over my benchtop.
—James J. Heusinger, Berea, Ohio

Plywood-scoring tablesaw insert

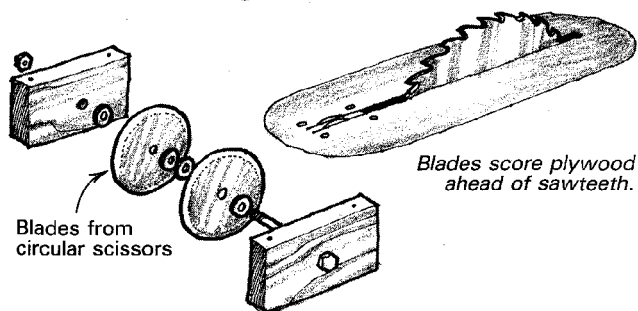

This device helps prevent the underside of veneered plywood from splintering by scoring the veneer just ahead of the blade. To make it, cut a snug-fitting insert blank from aluminum or plywood. Carefully raise the blade through it and enlarge the slot for clearance. With a straightedge against the teeth on each side of the blade, mark the outer edges of the blade's kerf on the front section of the insert. Cut along these lines with a thin saw to create two slots just ahead of the blade.

The scoring assembly uses two circular blades from the relatively new circular scissors made by Olfa. Spare blade packs for the scissors should be available at sewing and fabric stores. Make up a pillow-block assembly with a bolt axle to attach the scoring blades to the underside of the insert. Use regular washers, as well as shim washers punched from an aluminum can, to space the blades on the axle. Bolt the scoring assembly under the insert, making sure it will clear the sawblade and housing when in place. Ideally, the scorers should make a shallow cut ($\frac{1}{32}$ in. to $\frac{1}{16}$ in.) in the plywood very slightly wider and in line with the kerf of the blade.

—Sandor Nagyszalanczy, Santa Cruz, Calif.

Roller-stand adjustment mechanism

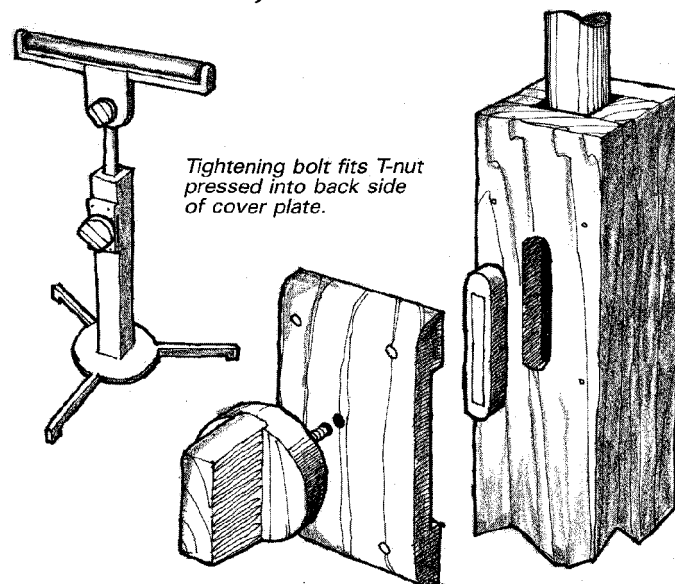

The main differences between this roller stand and other designs I've seen are the ease of adjustment and the tilting head. The tilting head, together with the three-legged base, makes it easy to cope with a shop floor which, like mine, isn't level.

The arrangement for adjusting the height consists of a bolt threaded through a T-nut pressed into the inside of a cover plate, as shown in the drawing. The head of the bolt is captured in an oak knob, which permits easy hand-tightening. The bolt does not bear directly on the sliding dowel, but on a loose wooden insert set in the post. This permits smoother adjustments and prevents the bolt from chewing up the dowel. The insert itself is protected by a brass wear strip.

—Timothy D. Anderson, St. Paul, Minn.

Featherboard variation

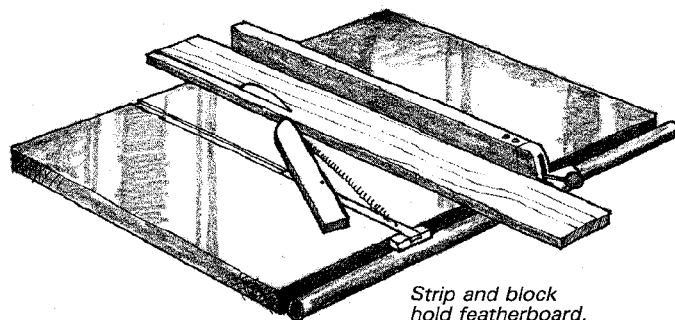

I use a variation of Arthur Kay's featherboard (*FWW* #55) that is very quick to install and remove. My featherboard is fastened to a strip of $\frac{1}{2}$ -in.-thick wood that's a snug fit in the miter-gauge slot. A small block on the end prevents the strip from sliding toward the back of the saw. The featherboard itself is fastened to this strip from below by a screw and is held in tension against the stock being ripped by a spring. I reversed the traditional shape of the end of the featherboard so that it would bear on the stock as closely as possible to the front of the blade, yet still clear the teeth when the stock being ripped passes through.
—Harold W. Books, North Platte, Nebr.

Aligning pins with holes in table leaves

Here is a simple method for aligning the pins in table leaves with holes in the expanding table's top. Before gluing up the tabletop and leaves, take a piece of the tabletop stock and drill

the pin holes squarely through it using a drill press. Then rip this piece into several 1-in.-wide strips, enough to laminate a strip to all interior edges. All that remains is to carefully glue up the top and the leaves with a strip on each edge where pins and holes must mate.

—*Kathleen Sillick, Gasport, N.Y.*

Sorting pan and funnel

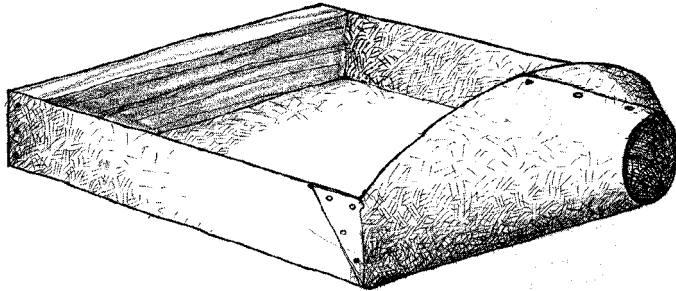

I keep a wide assortment of screws, nuts and bolts in cans with several sizes in each can. To find the item I want, I dump the can's contents into the sorting pan, where it is easy to find what I need, then I use the built-in funnel to pour the contents back into their container.

I used sheet aluminum to make the pan because it is more ductile than galvanized steel. The drawing gives the basic idea, but it has been simplified a little for clarity—a couple of refinements on my pan include cove molding glued around the bottom so things don't lodge in corners, and a stiffened top edge, made by rolling the aluminum around a length of wire.

—*L. Byron Burney, Raleigh, N.C.*

Quick tip: A handy trick for keeping furniture plans in good shape, instead of letting them kick around the shop, is to tape them to a roll-up window shade. They're available at the tug of a cord, and the light shining through them makes them very easy to read.

—*Frederick J. Miller, Chatsworth, Ont.*

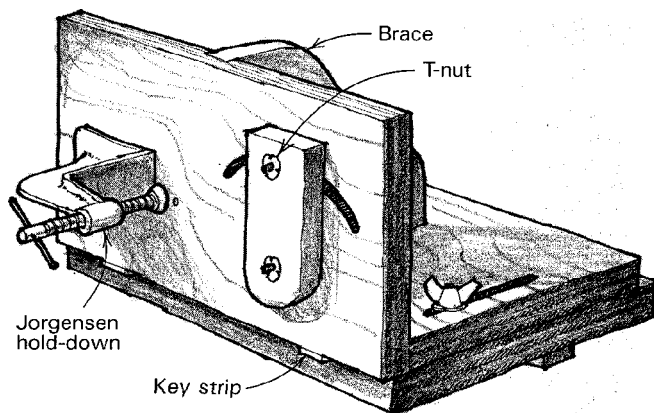

Faced with cutting 32 tenons on a recent project, I priced a new Delta tenoning jig and found it beyond my budget. So I put myself to work and made the jig pictured here at the cost of a few 3/4-in. plywood scraps and some hardware items already in my shop. It consists of a baseplate that rides along the miter-gauge slot, and a top table that adjusts closer to or farther from the sawblade. The work is clamped both against the jig's face and a vertical stop block, which can be pivoted to an angle if necessary.

To cut the tenons, I installed two identical 8-in. blades on my saw arbor with a 1/2-in. spacer between. I had the 32 tenons cut in no time.

—*Harrie E. Burnell, Newburyport, Mass.*

Emery-cloth sanding spool

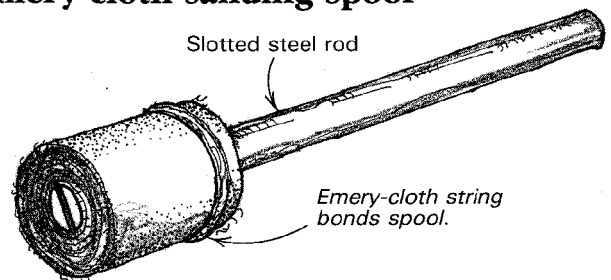

I first discovered how to make these emery-cloth sanding spools 35 years ago, when I used them to finish steel forging dies. Start by hacksawing a slot in a 3/8-in. steel shaft. From a sheet of emery cloth, rip a ribbon slightly wider than the slot. Insert the ribbon in the slot and wrap by turning the shaft in the direction it will rotate. So far, what you've made is a flap sander, but there's an improvement.

From the sheet, rip a second ribbon, keeping this one string-like, just about 6 or 8 threads wide. Wrap it around the lower part of the spool as shown in the sketch. Drop a little water on the string and, while holding a piece of scrap wood tight against the spool, turn on the drill to "burn in" the string. The glue in the threads of the string will bond tightly, banding the emery cloth into a firm spool that will last longer, sand smoother and won't flap all over your project.

—*Larry Stedman, Flushing, Mich.*

Quick tip: I keep my power-carving bits organized by drilling shank holes in old thread spools, and storing these in pill bottles from the drugstore.

—*J.R. Karnes, Columbus, Ohio*

Making dowels the colonial way

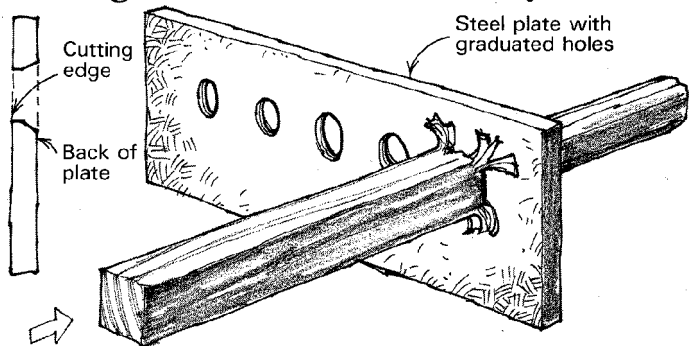

In colonial times wooden pegs were often made by driving a square stick through a round hole in a steel plate. I haven't read much about the technique lately, but it still works. Drill a hole of the desired dowel diameter in a 1/8-in.-thick steel plate, then drill a series of two or three more holes of slightly larger diameters. Countersink the back of each hole, as shown in the sketch, then stone the front surface flat and smooth to provide a good cutting edge.

To use, cut a square stick slightly larger than the final dowel diameter, whittle a tapered point on one end and drive it (from the flat side) through successively smaller holes. In sizes smaller than 1/2 in., it's best to pull the dowel through.

Mild steel is quite satisfactory for this purpose—when the die becomes dull, just drill a new series of holes.

—*H. Norman Capen, Granada Hills, Calif.*

Methods of Work buys readers' tips, jigs and tricks. Send details, sketches (we'll redraw them) and photos to Methods, Fine Woodworking, Box 355, Newtown, Conn. 06470. We'll return only those contributions that include an SASE.

Cutting wedges on the tablesaw

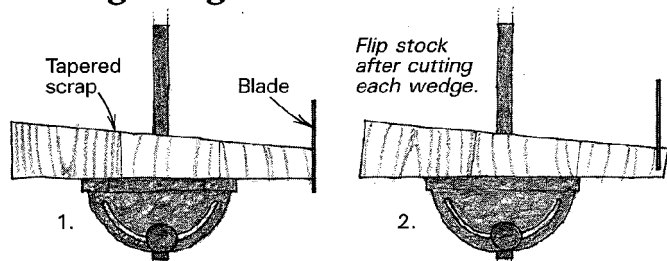

I like to use the wedged through-tenon joint, and have developed a way to cut consistently tapered wedges quickly on the tablesaw. The key to the method is to save the waste cut-off ends of glued up tabletops and the like. I use a tablesaw jig to taper one edge of these scraps at 1/2 in. per foot, or 2° (the taper shown in the sketch is exaggerated to about 5° for clarity). To cut wedges I simply crosscut the tapered scrap piece, flipping the piece after each cut. Rather than measure, I eyeball the width of the wedge, making sure to cut the thin end of the wedge smaller than needed. When fitting the wedge, I trim off the thin end with tin snips until the wedge fits the kerf in the tenon perfectly.

—C.M. Chappell, Houston, Tex.

Quick tip: I have a Sears tablesaw and a Sears router table, and I discovered one day that these two machines are compatible in a way that I never would have expected. To set the router table up, I slip two of its foot flanges under the tablesaw's rip fence; when I tighten the rip fence, it clamps down and holds the router table securely on top of the tablesaw, at a convenient working height.

—Craig Wynett, Charlottesville, Va.

Quick edge sander

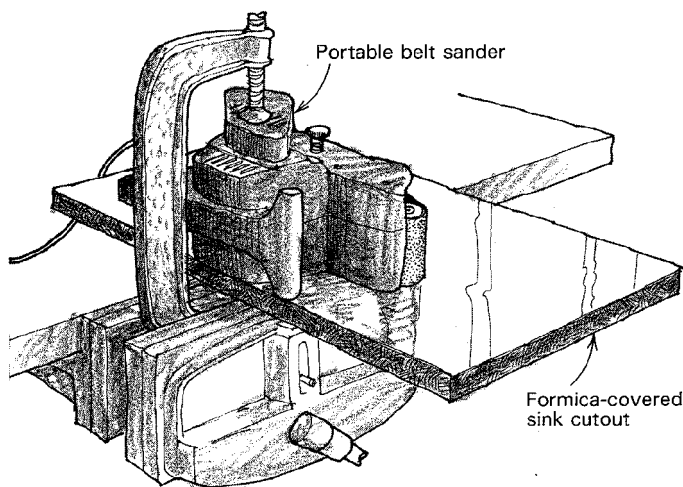

Here's how to convert your belt sander to an edge sander quickly and easily. Clamp a piece of plywood (I use a Formica-covered sink cutout) to your belt sander with a large C-clamp, as shown in the sketch. Then tighten the clamp in your work bench vise.

—Bob Elliott, Ankeny, Iowa

Plastic film protects workbench

If you're tired of cleaning dried glue residue off your workbench, try covering it with a piece of clear plastic film. I use the 4-mil-thick film that is available at many hardware stores for covering windows. Glue drops that fall onto the film dry quickly and, once dry, can be easily cleaned off by pulling the plastic over the edge of your saw table. The residue will peel right off leaving the film clean for your next project.

—Marilyn Warrington, Shiloh, Ohio

Anchoring wood posts to concrete

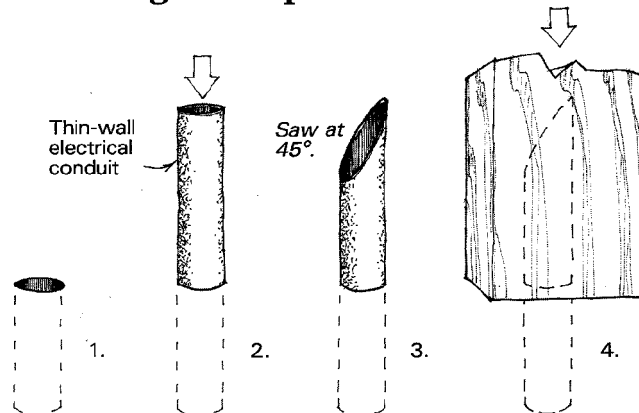

Here's a simple but strong method of anchoring wood posts to a concrete floor. First drill a 5/8-in.-dia., 2-in.-deep hole in the floor. Force-drive a 6-in.-long scrap of 1/2-in.-i.d. thin-wall electrical conduit tubing into the hole. Saw the tubing at a 45° angle 2 in. above the floor. Now accurately position your post over the anchor and sledge-hammer the post onto the tubing until it is down tight to the floor. Use two anchors if the post must resist twisting.

—H.J. McCurry, Jr., Lilburn, Ga.

Quick tip: I have a grinder with a goose-neck light mounted directly on it, and the vibration causes even a "severe-service" bulb to blow out within a few minutes. The solution turned out to be a 40-watt appliance bulb, for use in stoves and refrigerators. It is tough, and just bright enough. I've heard since that a bulb from a stop-and-go traffic light would also serve, but where to find one?

—Gordon Mulholland, Streator, Ill.

Nail jugs

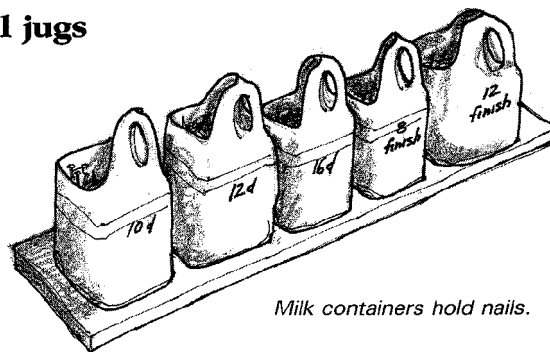

Milk containers hold nails.

When my new house was completed I collected quite a variety of half-full nail bags from the site. To make the collection readily available, I trimmed the necks off plastic milk cartons, marked each jug with the size of its contents and stocked them neatly on wall shelves. The jugs are convenient, durable and ready to transport to any project.

—Ralph E. Hall, Pisgah Forest, N.C.

Quick tip: Here's a simple tip for those of us who continue to drop our tablesaw's arbor nut into the sawdust when changing blades. After you've loosened the nut, place your index finger on the end of the arbor shaft and use your thumb to spin the nut off the shaft and onto your fingertip. The system works equally well in reverse.

—J. Hugh Capron, Winona, Minn.

Lowering a radial-arm saw

Here is a dead-simple method for quickly and precisely lowering the blade of a radial-arm saw just enough for through-cuts. Lay a playing card (which you keep conveniently on top of the arm assembly) on the saw table over the saw's line of

travel. Lower the blade onto the card until it buckles slightly but obviously under the pressure of the blade. The blade is then just at the correct level for through-cutting.

I invented this little trick after lowering the blade into the table with a thud several times, which I figured wasn't doing any good to the blade, the lowering mechanism or the saw's alignment.
—Raymond Francis, Pelham, N. Y.

Quick tip: I was making a cabinet with a shelf that was curved the length of its front edge. The shelf was plywood and the edge had to be banded, but how was I to true the band-sawn curve to make a hairline joint? A technique from lens grinding came to mind: I used a length of one of the curved offcuts as a sanding block; some sanding soon produced a perfect arc.
—John W Williams, Bellevue, Wash.

Double-duty marking gauge

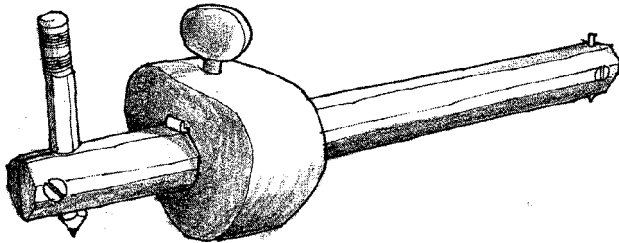

To double the usefulness of a marking gauge, install a pencil in a screw tightened hole at the unused end. There are many situations where a pencil line is preferable to a scratch. One can also put an india-ink drafting pen in the hole and draw nice smooth lines parallel to an edge—they look very much like ebony inlay.
—Simon A. Watts, San Francisco, Calif.

Quick tip: The best way to fit a miter gauge to its slot is to measure the gap with a feeler gauge, then epoxy appropriate brass shim stock along the full length of the bar. Shim stock is available in various thicknesses—from foil-thin on up—at auto supply stores. If the resulting fit isn't perfect, a little sanding will make it so.
—Jacob Schulzinger, Houston, Tex.

Dust-collection system improvements

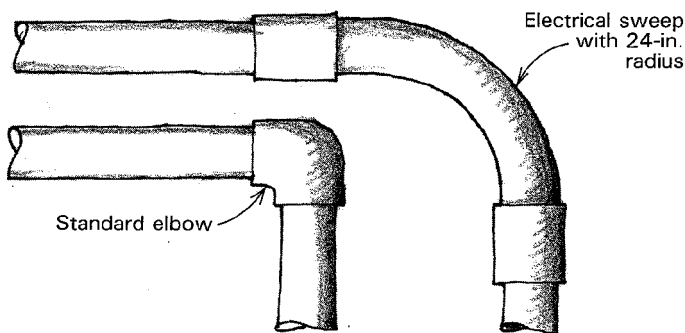

When I put together my dust-collection system using common 4-in. PVC pipe I found that, with all the 90° elbows that were necessary, the air flow was restricted and inefficient. Then, at an electrical supply house, I discovered a special 24-in.-radius PVC elbow called an electrical sweep. The new wide-turn elbows have solved my air flow inefficiencies.
—John S. Gallis, Deer Park, N. Y.

Quick tip: The plastic spreaders sold at auto parts stores for spreading body putty make excellent glue applicators for wood glue. They are flexible, available in several sizes, easy to clean and inexpensive.
—Richard Pallaria, Cochection, N.Y.

Removing black water stains from oak

To bleach out black water stains on oak use a 20% solution of phosphoric acid. For safety's sake, don your goggles and rubber gloves, then just brush the acid solution on the oak and put it out in the sun. Neutralize the acid after it is dry with a TSP (trisodium phosphate) or bicarbonate of soda solution. I use this procedure on old oak barrels and find it more effective than the two-step oxalic acid system sold in paint stores. The phosphoric acid also removes rust deposits from iron and steel, much the same as Naval Jelly.

—Peter S. Birnbaum, Sebastopol, Calif.

Making tiny drill bits

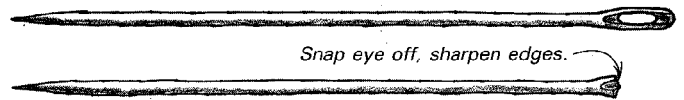

Drill bits of 1/32 in. or less are hard to find, expensive and break easily. But in minutes you can make a tiny drill bit from an ordinary sewing needle. These are readily and inexpensively available in a multitude of small sizes. To make a bit, use two pairs of pliers to snap the needle right at the bottom of the eye. The resulting blank is too hard for filing but, if held in a pin vise, can easily be stoned by hand to yield good cutting edges. (A Foredom Micro Chuck that will adapt your regular chucks to hold hair-thin bits is available from Woodcraft Supply, 41 Atlantic Ave., Woburn, Mass. 01888.) I have used these needle-bits not only in marquetry, where they are indispensable, but also for drilling 1/60-in.-dia. holes 1/2 in. deep in oak.

—Edward C. Kampe, Zellwood, Fla.

Quick tip: Recently I came across an office-type paper cutter that could no longer cut paper. I tried it on veneer, however, and was amazed. It works very well, and will cut veneer at any angle to the grain.
—Herb Kuschel, Jefferson City, Mo.

Lag screws in endgrain

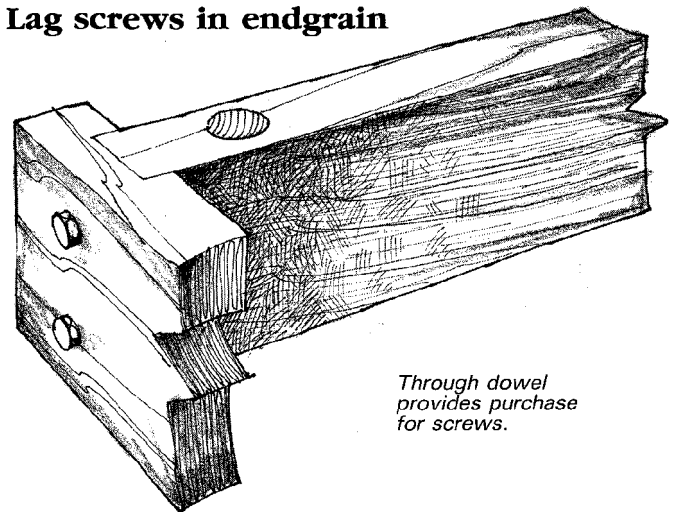

Lag screws driven into endgrain are weak and won't hold under pressure. But if you drill a hole through the member and add a dowel as shown, the screw can bite into the long grain of the dowel and turn a weak dado into a strong, practical joint. I used this construction to connect the front and side rails of a knockdown pine sofa frame.
—Jack Fisher, New Hope, Penn.

Methods of Work buys readers' tips, jigs and tricks. Send details, sketches (we'll redraw them) and photos to Methods, Fine Woodworking, Box 355, Newtown, Conn. 06470. We can return only those contributions that include an SASE.

Pattern sanding

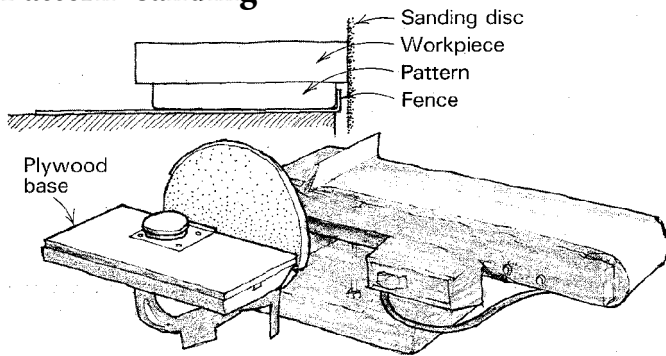

When I needed to reproduce 100 small ovals from 1/4-in.-thick wood, I experimented first with several router methods, which proved either defect-prone or dangerous. I solved the problem by pattern sanding the ovals on a 12-in. disc sander. I suspect the same technique could be adapted to a belt sander with equally good results.

Only two parts are necessary, a pattern and a guide fence. I made the pattern from 1/4-in.-thick Plexiglas, which I shaped and smoothed on the disc sander. Because the pattern rubs against the guide fence, it must be sized about 1/8 in. smaller than the dimensions of the finished work and should be chamfered on its bottom edge for dust clearance. The guide fence is simply a 4-in. square of sheet metal with one edge bent up to a 3/16-in. lip. Attach the guide fence to a plywood base with countersunk screws so that the lip overhangs one edge of the plywood slightly. Now clamp the plywood to the disc sander table with the guide fence next to, but not touching the disc.

To use the device, fix the slightly oversize workpiece to the Plexiglas pattern. To keep the workpiece from slipping, use sandpaper, double-sided tape or protruding brad points. I've found that a sheet of sandpaper glued to the top of the pattern provides enough friction for most situations. Push the pattern against the sheet-metal fence and rotate it to grind the workpiece to shape. With 100-grit sandpaper, the whole operation takes about 30 seconds for a small, uncomplicated shape. The fixture shown may be used to form straight or convex shapes only. However, concave shapes could be easily cut using a similar device that incorporated a curved guide fence and small drum sander.

—Don Herman, Brechsville, Ohio

Quick tip: To cut sandpaper discs to size I keep a pair of dividers with one leg sharpened to a knife edge. I just scribe the exact size needed on the back of the sheet and cut the disc free with one or two passes. The dividers also excel at scribing wood.

—Carl Meinzinger, Guenes Island, Wash.

Preventing clamp stains during glue-up

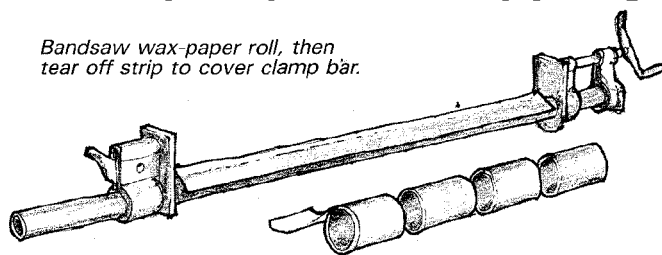

Here's a simple solution to stains caused by wet glue reacting with metal clamps. Bandsaw a roll of ordinary wax paper into 2-in. mini-rolls. Tear off what you need, fold into a tent shape and lay the wax paper on the clamp as shown.

—Dustin P. Davis, Frostburg, Md.

Bench screws for carving

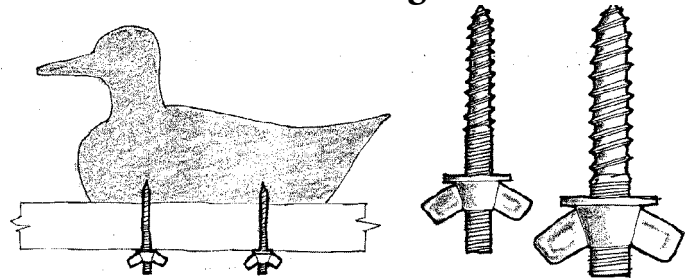

Except for their expense, bench screws are the ideal solution for fixing carving blanks to the workbench. Fortunately, you can duplicate their function for mere pennies. Ask at your local hardware store for hanger bolts. These bolts, which are available in a variety of smaller sizes and lengths, have a wood screw on one end and a machine screw on the other. Replace the nuts that come with the bolts with wing nuts and you have virtually duplicated a \$20 benchscrew.

The hanger bolts will be more than adequate for holding smaller carvings. But larger carving blanks call for a heftier bench screw. To make one, hacksaw the head off a lag screw as big as you need and thread the shank with a standard die. Fit the screw with washers and a wing nut and you have a monster bench screw.

—Ford Green, San Antonio, Tex.

Quick tip: You don't need two hands to adjust a C-clamp. Try this: grab the end of the T-handle and let your arm and the clamp hang down toward the floor. Move your hand as if stirring paint, and you'll find that the clamp body will rotate around the screw.

—John McDermott, Rexton, N.E.

Lathe sizing tool

Tool gauges dowel size.

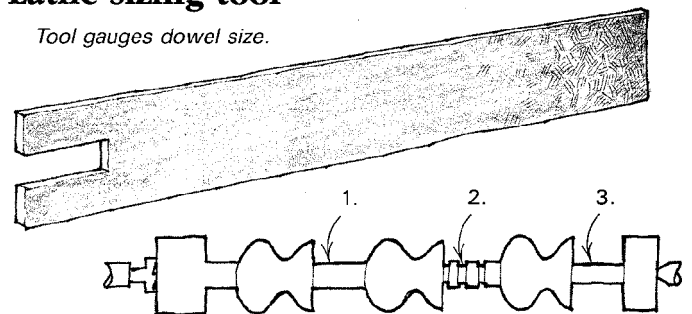

I turn many wooden knobs in multiples of four, and I needed a quick and accurate procedure to put 1/2-in. dowel stems on each knob. This easy-to-make sizing tool does the job beautifully. Start with a 12-in. length of 3/8-in.-thick steel. Square the end and cut a 1/2-in.-wide slot 1 in. or so deep into the end of the bar. File the slot to exact size. You may wish to bevel the tool's cutting edges above and below the slot, so they have a shape similar to the cutting edge of a parting tool. However, I found that the sizing tool will function perfectly well with sharp, square corners. To use the tool, first turn the knobs to shape with their stems slightly oversize (1). Plunge the sizing tool down on the stems at 1/4 in. intervals to produce bands of the true dowel size (2). Then bring the remainder of the dowel down to size with a parting tool or chisel (3).

—J.C. Collier, Upper Hutt, New Zealand

Layout procedure for routing dadoes

Here's my pet method for routing dadoes in plywood. First locate and mark out the dado on the workpiece and score the veneer with a sharp knife. Set a compass to the distance from the edge of your router base to the bit. For example, if your

router base is 6 in. across and you're using a $\frac{3}{4}$ -in. bit, set the compass to $2\frac{1}{2}$ in. With the compass point on one edge of the dado, swing two arcs—one at each end of the dado. Now clamp a straightedge tangent to the arcs to serve as a fence and you're ready to rout. —Chuck Anderson, Porterville, Calif.

Adjustable go/no-go lathe gauges

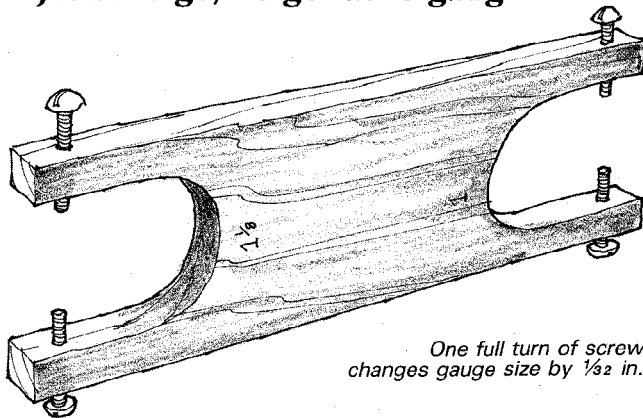

One full turn of screw changes gauge size by $\frac{1}{32}$ in.

A set of these shopmade gauges will make measuring diameters easy and precise. Start with a length of $\frac{3}{8}$ -in.-thick, close-grained hardwood. Cut U-shaped recesses in each end slightly larger than the diameter to be measured and trim the piece so that the "arms" of the gauge end up about $\frac{3}{8}$ in. square. Next, using a $\frac{3}{4}$ -in. bit, drill holes for the adjustment screws in each arm as illustrated. These holes should be $\frac{1}{4}$ in. from the ends, square and centered.

Now install four 1-in.-long, size 8-32 machine screws in the holes. Turn the screws right into the holes—no tapping is necessary. In fact, the self-cut threads will make lock nuts unnecessary. Round over and smooth the ends of the screws to increase accuracy. Now you're ready to set the gauge to the required dimension with an inside caliper or any convenient standard. One full turn of the screw makes a $\frac{1}{32}$ -in. change in the gauge dimension. —R.H. Taylor, Southport, Conn.

Quick tip: Everybody has seen adjustable shelf systems consisting of a vertical standard screwed to the wall and a shelf support that locks into slots at various heights. I mounted such a standard to a leg on my workbench and now I can adjust the "shelf support" to help position long work held in my bench vise. —Ben Terlecki, Oshawa, Ont.

Crank adjustment for router table

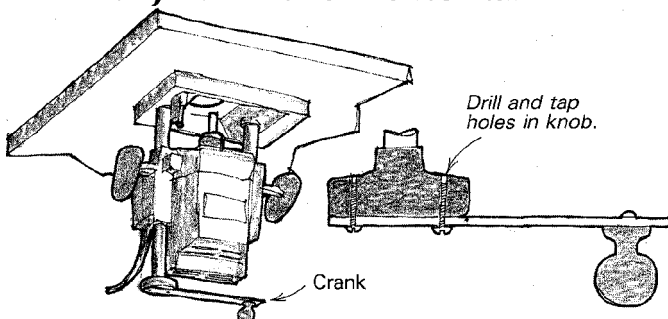

The Makita plunge router I have installed in my router table works beautifully. But adjusting the depth of the bit with the adjustment knob was awkward and tedious. I solved this problem by removing the pre-load springs from the router support tubes. Then I fashioned a simple crank handle that screws to the existing knob. Now I can adjust the router quickly to whatever depth I need, —Robert T. Combs, Carpinteria, Calif.

Gaining length on a lathe

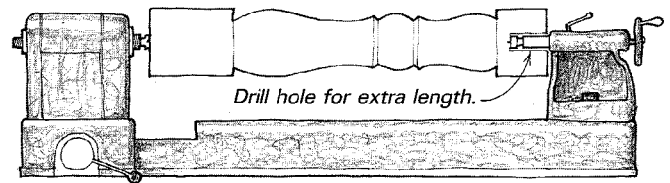

When I wanted to turn a set of fancy 6x6 Victorian newel posts, I found my lathe's capacity was 2 in. short of the required length. Finally I discovered the method illustrated here, which gave me the extra 2 in. and paid a safety bonus as well. I drilled a hole, the same diameter as the tailstock, 2 in. deep in the center of one end, dropped the tailstock into the hole and mounted the work on the lathe. After the workpiece is in place for turning, it's impossible for it to fly off the lathe.

—Dan Miller, Elgin, Ill.

Wooden box hinge

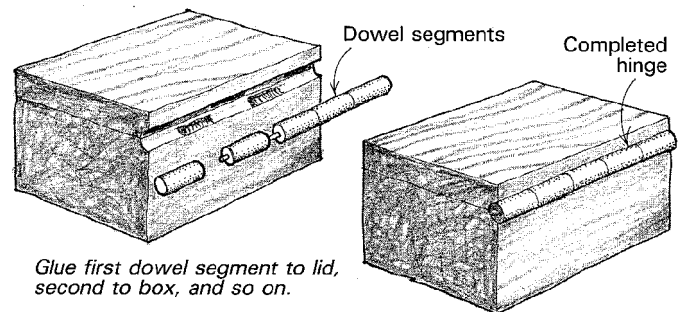

This wooden hinge is tricky to make. But because it's distinctive, attractive and functional as well, perhaps the extra trouble is justified.

To make the hinge you'll need a $\frac{1}{2}$ -in. or $\frac{3}{8}$ -in. dowel, preferably from the same wood as your box, a brazing rod pin as long as the back of the box and a core-box router bit to rout a round bottomed slot the same diameter as your dowel.

Start by determining the number of hinge segments you wish to have. There should be an odd number, and each segment should be no longer than $1\frac{1}{2}$ in. or so. Divide the length of the box back by the number you have chosen to get the length of each dowel segment. Now carefully slice up the dowel taking care that each segment's end is a perfect 90° . The next step is to drill a hinge-pin hole through each of the interior segments and halfway through both of the end segments. The pin hole must be perfectly centered in each segment. I've seen several ideas in the Methods of Work column to accomplish this operation. The easiest, I think, is to clamp a 2x4 to the drill-press table and drill a registration hole the same diameter as the dowel about $\frac{3}{4}$ in. deep into the 2x4. Without moving the drill-press table, chuck the bit you intend to use for the pin holes into the drill press. When you place a dowel segment in the registration hole, the pin bit will be centered right over it.

Now you're ready to rout a round-bottomed channel centered over the seam where the top of the box meets the back. You can rout this channel by clamping the top to the box and using a core-box bit or, alternatively, you can rout the top and back separately with a piloted cove bit. Either technique will work.

When you have completed the hinge channel, you're ready for the tricky part—gluing the hinge in place. First string the dowel segments on the pin wire like beads with an end segment on each end. Lay the hinge in the channel between back and top and mark the location of each segment. Carefully smear dabs of glue in the channel, alternating between top and

back so that half of the segments will be glued to the top and half to the back. Don't use too much glue, because any squeeze out will lock up the hinge. I've experimented with several types of glue and have had the best luck with epoxy, even though I normally avoid it. Place the hinge into the channel and clamp lightly to minimize squeeze out. When the glue sets, remove the clamp, cross your fingers and try the hinge action. If all has gone well, you will have a smooth-working, good-looking hinge. —*Jeris Cbamey, Ponca City, Okla.*

Sliding tablesaw carriage

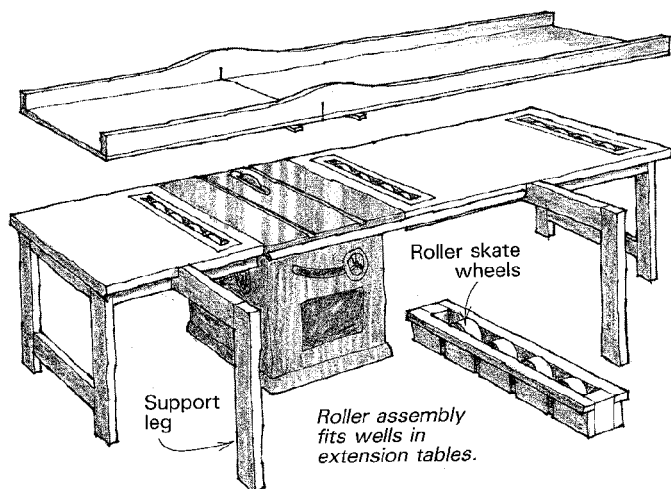

If you've ever attempted to crosscut a 6-ft.-long, 2-ft.-wide panel on the tablesaw, you know the operation is awkward, error-prone and even scary. By contrast, when you add the sliding carriage described here, tablesaw crosscutting is made more accurate, faster and safer. The fixture is straightforward with two main components: an auxiliary bed fitted with rollers made from skate wheels, and a sliding carriage that rolls atop the bed, using the miter gauge slots as a track.

The auxiliary bed fitted with rollers is really the key to the fixture. Without the rollers the heavy sliding carriage would stick and bind. To make the auxiliary bed, first construct two outrigger tables to bolt up to the saw as shown. The size of the tables is discretionary, of course, but I recommend that the tables-plus-saw add up to at least 8 ft. long. The rollers are made up in three box frames, each containing four nylon roller skate wheels mounted on 1/4-in. threaded-rod axles. The roller boxes drop into wells in the top of each outrigger table as shown. The boxes pop out when they are not in use and can be replaced by plain plywood inserts. It is a good idea to design in some sort of height adjustment for the rollers in case they are too low or too high in use.

The sliding carriage is nothing more than a large panel of plywood with fences fixed to the front and the back edges. Waxed maple runners screwed to the bottom of the carriage slide in the miter gauge slots and ensure the table tracks at right angles to the blade. I bolted the fences to the panel using slotted holes so that I could adjust the fences for a perfectly square cut.

Because the sliding table is heavy, another necessary component of the fixture is a support stand to hold the table when it's pulled back toward the operator before the cut. You may choose to incorporate this support into the design of the auxiliary bed. In my case I made up a couple of removable legs I can fasten in place whenever I use the sliding table.

One side-benefit of the fixture is that you may use the roller feature without the sliding carriage. The rollers make ripping a full sheet of plywood a breeze. —*Bill Amaya, Hailey, Ind.*

Foot switch for tablesaw

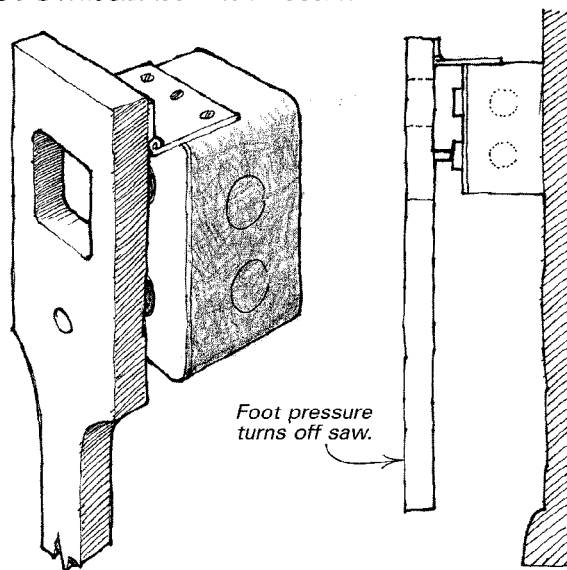

This foot switch is for those of us who, with both hands critically occupied on top of the saw table, have wished for a third hand to reach under the table and turn off the saw. I added the switch to my saw primarily for safety reasons but now find its convenience indispensable. The foot switch is simply a hinged paddle that hangs down over the saw's push-button switchbox. I can turn off the saw by bumping the paddle with knee or foot—a short dowel located at just the right spot pushes the off button. A hole through the top part allows normal finger access to the on button and, in fact, offers some protection against the button being pushed accidentally.

—*Eric Eschen, Chico, Calif.*

Turning hollow spheres

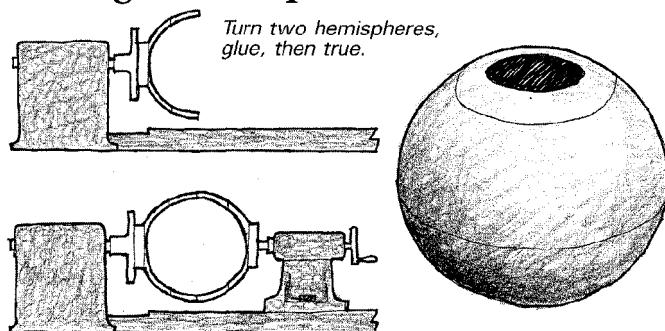

For those of us who have neither the tools nor the skill to hollow out a solid sphere on the lathe, here is an alternative. First glue up two blanks using truncated wedge segments and solid wood caps (see "Segmented Turning," *FWW* #54). Turn two hemispheres, as shown in the sketch above, and glue them together after they have been hollowed to the desired wall thickness, leaving some extra thickness to allow for truing later. To glue the hemispheres together I leave one hemisphere attached to its faceplate in the lathe and use the tailstock to apply pressure while the glue sets. It is a good idea to leave the tailstock in place for extra support while you true the sphere to its final shape. —*Al Brotzman, Madison, Ohio*

Methods of Work buys readers' tips, jigs and tricks. Send details, sketches (we'll redraw them) and photos to *Methods of Work*, Fine Woodworking, Box 355, Newtown, Conn. 06470. We'll return only those contributions that include an SASE.

T-nut handscrews

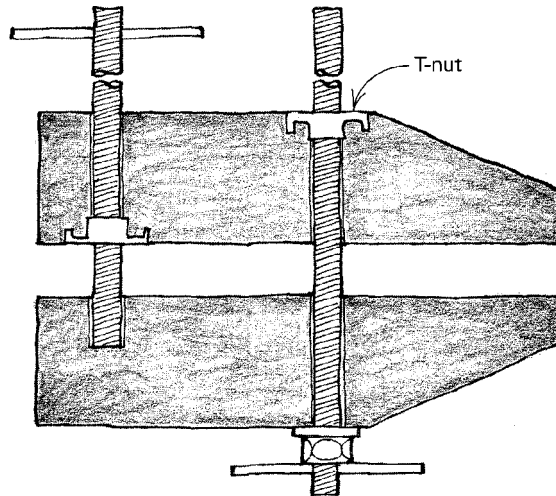

For a few cents worth of hardware you can transform a couple of pieces of scrap into durable small handscrews. The sketch shows the general construction idea. Handles could be turned from wood, but I just use T-bar handles made from 1½-in.-long pieces of brazing rod that press-fit into ⅜-in. holes in the threaded rod. Note the nut and washer on the front screw (to leave space between the handle and the clamp) and the flat bottom on the back hole (to prevent the threaded rod from splitting the clamp). I like to counterbore the T-nuts for a neater appearance and put a dab of epoxy under them to make sure they stay in place. —Chuck Anderson, Porterville, Calif.

Yet another clamp

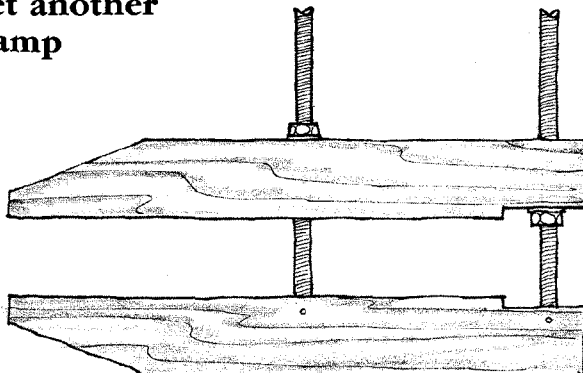

These clamps, which are patterned after a set of steel ones made years ago by the grandfather of a fellow worker, are inexpensive, easy to build and suit my small work better than purchased models. Over the years I have made several sets in a variety of sizes.

Construction is straightforward. Select a strong, hardwood such as oak or maple and cut two identical jaws. Clamp the two jaws together and drill the two threaded rod pilot holes. The holes should run through the top jaw and about an inch deep into the bottom. Enlarge the through holes in the top jaw to slip over the threaded rod. Although it is not necessary, you may wish to cut steps at the backs of the jaws, as shown, so that the jaws can be tightened down to zero. Tap the holes in the bottom jaw and screw in the lengths of standard threaded rod. Next drill a ⅛-in. pin hole through the cheeks of the jaw and through the threaded rod. Pin the threaded rod in place with a finish nail. Ordinary washers and nuts installed as shown in the sketch finish the clamps. For large clamps you can buy "Quick Acting Hand Knobs" from Reid Tool Supply Co., 2265

Black Creek Road, Muskegon, Mich. 49444 (part No. QK1, \$3.26 each). When these knobs are tilted, they slide freely along ¼-20 threaded rod, allowing quick adjustment.

To use the clamps, first adjust them to the work, keeping the jaws nearly parallel. Tighten the outside nut gently and use the inside nut to apply pressure. Use a light touch. These clamps can develop awesome force with just a few turns of the screws. —Raymond Levy, Soquel, Calif.

Ersatz router plane

Sharpening guide steadies chisel.

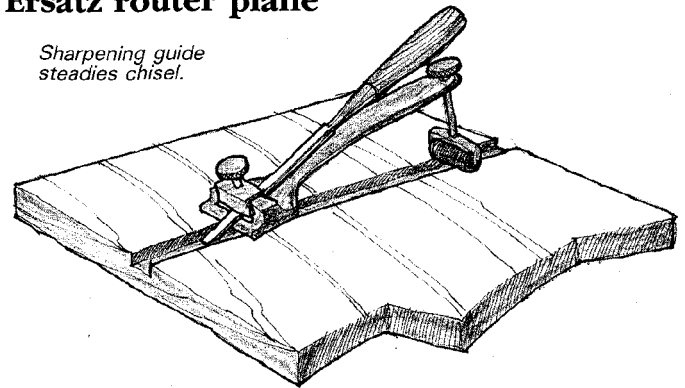

If you don't own a router plane but need to clean out a few dados fresh from the tablesaw, try mounting a ¼-in. mortising chisel in a sharpening guide. Adjust the chisel for the desired depth of cut and proceed. Go gently. If you push the tool too hard or too fast the chisel may chatter out of adjustment or make an unwanted submarine dive into the dado.

—Richard Melloh, Plainfield, N.H.

Drawing a half-ellipse

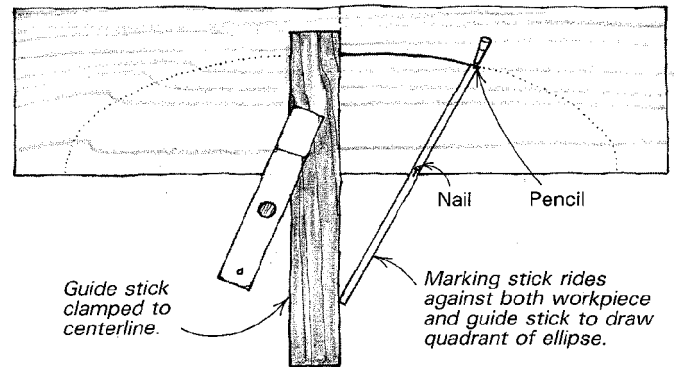

We use this method to lay out seat backs in our shop. First mark the rise and run of the half-ellipse on the stock and clamp a 1x2 guide stick on the centerline, as shown in the sketch. Now cut a 1x1 marking stick half as long as the ellipse and notch one end to hold a pencil point. Drive a nail through the stick at a distance from the notched end equal to the rise of the ellipse. To draw the ellipse, hold a pencil in the notch and move the head of the stick from left to right while riding the nail against the stock and the tail of the stick against the guide stick. Reclamp the guide stick to the other side of the centerline to complete the curve. —Doug Hansen, Lercher, S. Dak.

Sharpening center punches

Here's how to put a perfect cone-shaped point on the end of a punch. You'll need a grinder fitted with a 6-in. coarse wheel, a small electric drill and a small piece of heavy cardboard. Wet the cardboard thoroughly, wrap it around the barrel of the punch and let it dry overnight in place. The next morning

spring open the cardboard and grease the inside lightly. This cardboard tube is your guide bearing and friction insulation. Now chuck the punch in the drill and, holding the spinning punch with the greased cardboard tube, bring the punch to the rotating grinding wheel. Grind the point to shape on the edge of the wheel but finish on the side.

—Ford Green, San Antonio, Tex.

Honing carriage

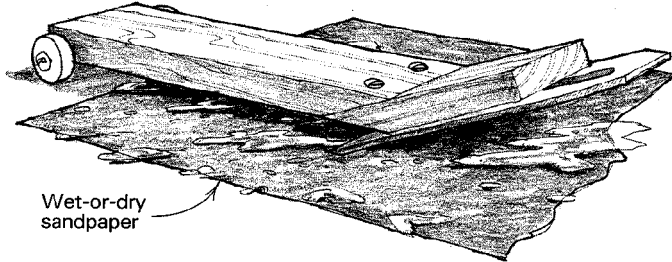

This simple honing carriage will enable you to hone your plane iron or chisels on a sheet of commonly available wet-or-dry abrasive paper. Select a 2 in. wide, 1/2-in. thick piece of hardwood about 9 in. long. Using a bevel angle of 20°, cut the board in two about 3 in. from one end. Rejoin the pieces with glue and two wood screws into a dogleg, as shown, and attach wheels—mine are nylon pulleys from an old drapery rod.

To use the carriage, screw the plane iron to the dogleg through the slot in the plane iron. The angle of honing can be adjusted from 20° to 30° by raising or lowering the plane iron. Make sure the blade is square to the working surface so that the entire bevel is honed evenly. Place a sheet of waterproof 240-grit silicon-carbide abrasive paper on a hard flat surface such as a sheet of glass or a piece of Formica. Keep the sandpaper flushed with water while you move the honing guide forward and back with the tool's bevel resting on the wet abrasive paper. Soon the sharpening action will produce a wire edge. Remove the blade from the carriage and strop by hand.

—Tom Frohlich, North Miami Beach, Fla.

Quick tip: I roll large plans and charts backwards—with the good side out—then protect the roll with a scrap sheet. When unrolled for use, the plans stay flat without having to weight the four corners.

—Roger S. Apted, Milton, Wis.

Sharing motors

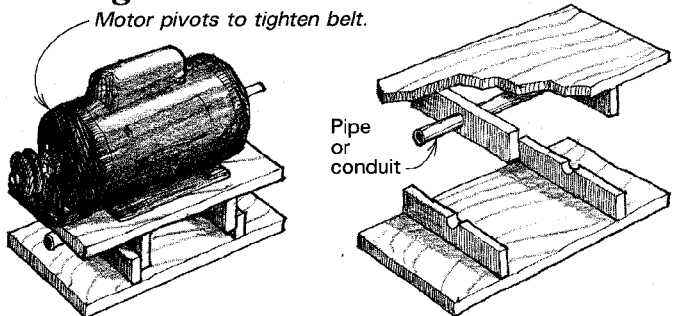

When I recently purchased some used equipment from the widow of a life-long woodworker, I found it unusual that several of his machines were missing a motor. But, when the motor almost fell off a machine I was carrying, I realized what the woodworker had done. On several of his little-used machines he had installed the same shop-made motor mount shown in the sketch, and consequently he could move a single motor from one tool to the next as needed. The mount is designed so that the motor pivots in the saddle and tensions the belt with its weight.

—Dan Miller, Elgin, Ill.

Homemade center finder

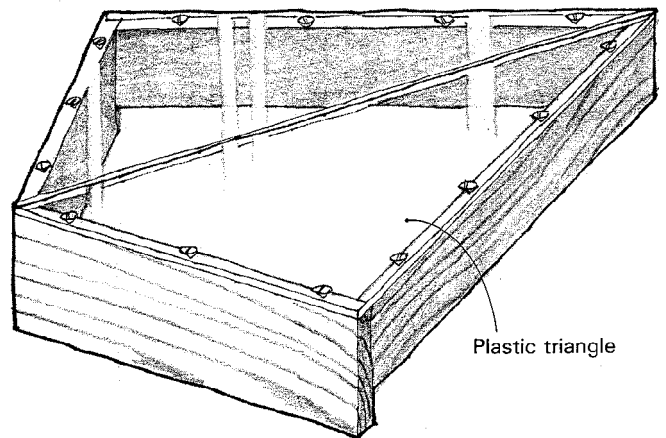

To make this inexpensive but accurate center finder, purchase two identical 30-60-90° triangles at an art or drafting supply store. The triangles are available in a variety of sizes. Attach the two triangles to a wooden frame using small brass screws. Leave a 1/8-in. space between the two triangles to provide a marking slot. On my center finder I made the frame deeper on the 60° end, as shown in the sketch, so I could use the center finder for marking objects too large to fit within the frame.

—Dave Sander, Port Orchard, Wash.

Fixture for turning feet on bowls

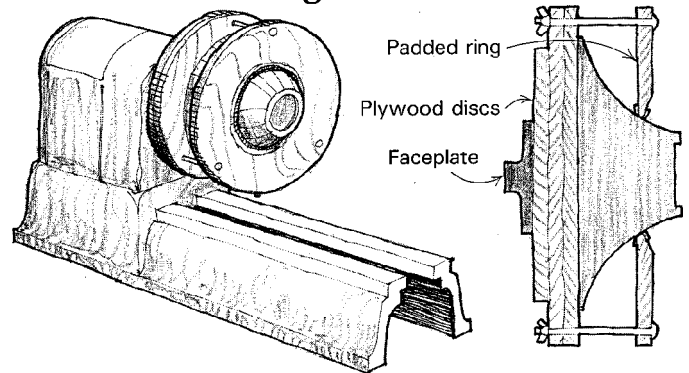

This fixture is for those woodturners who appreciate a neatly turned foot on the bottom of a bowl or plate. Unlike other fixtures I've seen, it won't bust your knuckles, lose the workpiece at the critical time or require much fussing to center the work. The easy-to-build fixture is made from one 9-in. disc, two 12-in. discs and one 12-in. ring—all cut from good quality plywood. Glue up the three discs into a solid base and mount them to a faceplate as shown in the sketch.

Now install three smooth-headed carriage bolts through the plywood ring into the base so that the work can be sandwiched between the ring and the base and tightened in place with wingnuts. It's a good idea to round and pad the inside of the ring so it won't mar the work. You may need several different rings, each with a different-size opening to handle various sizes of bowls and plates. To center work in the fixture, turn the work by hand as you tighten the wingnuts, adjusting the position as necessary—you can rest a pointed skew across the tool rest to use as a reference point.

—Doug Napier, Mansfield, Ohio

Milk-jug chisel protectors

A good, fast way to make chisel and knife-edge protectors is with plastic one-gallon milk jugs. Because these jugs are made of a thermoplastic, they can be easily shaped with heat and

pressure. I use a propane torch to heat the plastic until it turns clear. Then I press the tool edge straight into the plastic and hold it for a few seconds until the plastic cools. To finish I remove the tool and cut the plastic to the length required. This technique is also good for taking impressions of almost any small object to make plaster casts.

—Robert Kelton, Saranac Lake, N. Y.

Pipe-clamp bench slave

I made this bench slave from a pipe clamp, a pipe flange and a wooden base. It is especially useful in holding up the other end of a long board when hand planing in your bench vise. I have seen many wooden versions before, some with notches at various heights, others with lines of pegs and holes to allow a number of height adjustments. Undoubtedly, most of these have been more graceful and handsome than mine, especially when they have been well finished. The prime advantage of my stand is that unlike its wooden cousins, it is infinitely adjustable.

—Louis Sass, Eola, Ill.

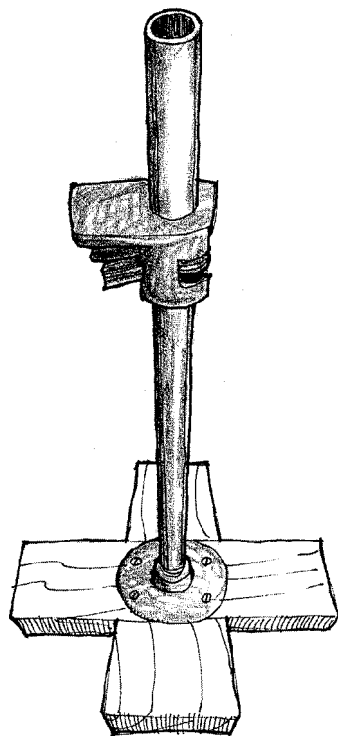

Quick tip: Plant-tie tape, available at garden supply stores, makes a good gluing clamp for small-to-medium jobs and irregular work. The tape is made of elastic plastic and comes in ½-in. and 1-in. wide rolls. The more you wrap, the tighter it clamps the work. —Robert Boardman, Nevada City, Calif.

Power wedges for edge-gluing

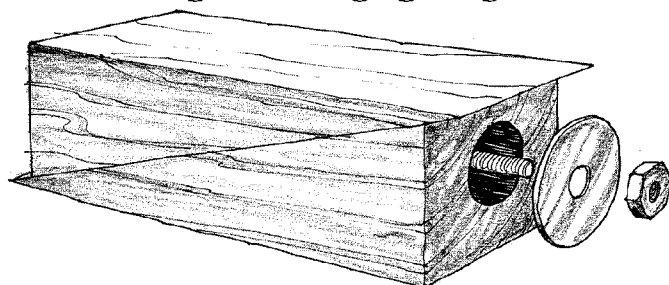

Small wedge pairs are a good way to clamp thin stock when edge-gluing (see *FWW* #58, p. 45) because the wedges won't exert too much pressure. But recently I needed to clamp a glue joint where the only thing that would fit were wedges, yet I had to apply a lot of clamping pressure to the joint. To solve the problem I came up with the power wedges shown below. These wedge pairs work just like the pairs you tap into place. But since they are tightened with a machine screw, you can apply much more clamping pressure.

Start with a rectangular block about 1 in. by 1 in. by 3 in. Drill an oversize hole lengthwise through the block, cut the block in two on the diagonal, then add a machine screw and washers as shown. —Richard Farwell, San Luis Obispo, Calif.

Routing tablesaw inserts

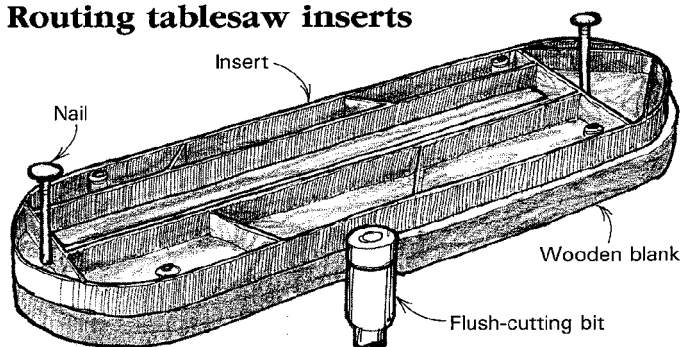

Drilling two nail-sized holes in your tablesaw insert lets you tack the insert to a rough-cut blank and pattern-route a replacement wooden insert that's exactly the size of the original. A flush-trim bit with a ball-bearing pilot works best for the routing. Before you start, thickness-plane the stock for the blanks to the exact depth of your insert hole. I make the inserts up by the dozen and put in a new one at each blade change.

—Jeffrey P. Gyving, Point Arena, Calif.

Kitchen baster handy in shop

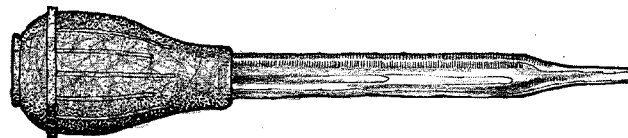

Transferring lacquer from a gallon can to your sprayer cup needn't be messy and awkward. Use a common kitchen baster like a jumbo eyedropper to transfer the finish. To maintain domestic tranquillity, don't steal the baster from your kitchen. Rather, go buy your own, making sure the body is nylon so that it is impervious to lacquer and lacquer thinner. The baster is useful in cleanup also. Use it to squirt solvent through gun orifices. —Chuck Anderson, Porterville, Calif.

Production turning with calipers

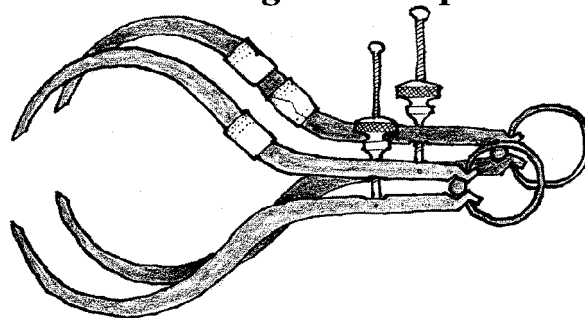

If you do much production-run spindle turning you have probably already discovered that it's much more efficient to use several calipers preset to various key diameters rather than to reset one caliper several times. But if you happen to pick up the wrong caliper at the wrong time it's easy to ruin the work. To reduce the chance of this error, I mark each caliper with bands of tape and set the calipers in the sequence used. The caliper for the first cut will have one band of tape, the second caliper two bands, and so on. This simple procedure has virtually eliminated mistakes. —Alan Dorr, Chico, Calif.

Methods of Work buys readers' tips, jigs and tricks. Send details, sketches (we'll redraw them) and photos to *Methods*, Fine Woodworking, Box 355, Newtown, Conn. 06470. We'll return only those contributions that include an SASE.

Perfect edges on rust-pitted tools

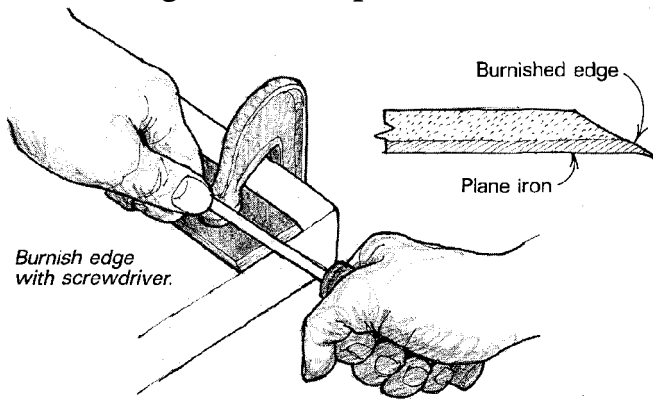

I discovered this sharpening technique while working on an antique laminated-steel plane iron with a rust-pitted back. There just wasn't enough steel to chase those nasty pits to the core to obtain a flawless edge. This technique, which I now use on all my edge tools, burnishes the edge down to provide enough metal for a perfect, work-hardened edge while leaving the back of the tool in its original shape.

Before starting the edge procedure, I gently remove the rust from the old tool with emery cloth, a wire brush or green pot scrubbers. Then, I rough-grind the tool to the proper bevel angle using a hand-cranked grinder and a common silicon-carbide wheel. Next, with the tool clamped to the bench as shown in the sketch, I burnish the edge with a screwdriver shank to produce a curl about 1mm tall. This burnishing operation isn't delicate; rather, it's a rough procedure requiring great pressure, determination, a tightly clamped workpiece and a safely dull edge. Burnish from the corners in to the center to avoid corner breaks. Western tool steel is tenacious, but it'll move if you press hard enough.

Next, I remove the burr and flatten the back of the edge by drawing the tool's back obliquely across a progression of flat stones. Since removing the burnished edge wears stones quickly, you may wish instead to use a sheet of emery cloth oiled or wetted to a sheet of glass. When the back of the edge is flat, you're ready to proceed with honing the edge in normal fashion. —Generik Tooles, Madison, Wisc.

Quick tip: To keep my files from rubbing together and wearing each other out, I made a storage bin for them by gluing up a stack of various short lengths of PVC pipe in 1¼ in., ¾ in. and ½ in. diameters. —Bob Boardman, Nevada City, Calif.

Stop molding for crowned frames

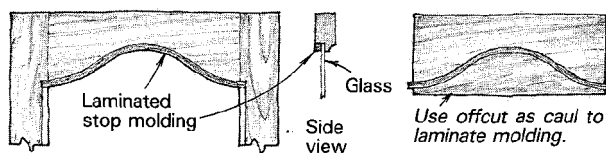

The usual procedure for making stop molding for glazed crowned frame doors is to bandsaw the molding from solid stock. This approach presents two problems. First, it's difficult to fit the curved molding to the frame. Second, the inevitable endgrain of the bandsawn piece is weak and prone to splitting when nailed in place. Both these problems can be eliminated by using laminated veneer strips to make the molding. I cut the strips slightly oversize in width, and use the actual door and its waste piece as a two-part form to shape the wetted and glue-coated veneer strips. After the glue has set, I plane and sand the molding to final thickness. —Bob Plath, Delhi, N.Y.

Making contoured sanding blocks

When you use intricate molding in your work and insist on a perfect finish, the time invested in making a reverse-image, contoured sanding block is justified, even if you have to hand-carve the block. But when you can cast a perfectly accurate sanding block in minutes, using the workpiece as its own mold, there's no excuse not to have one.

To make the sanding block, use scrap wood to construct a small box that's as wide as the molding and about 6 in. long. Mix up a small quantity of polyester auto body filler (I used Bondo) and partially fill the box with the putty. Now, cut a

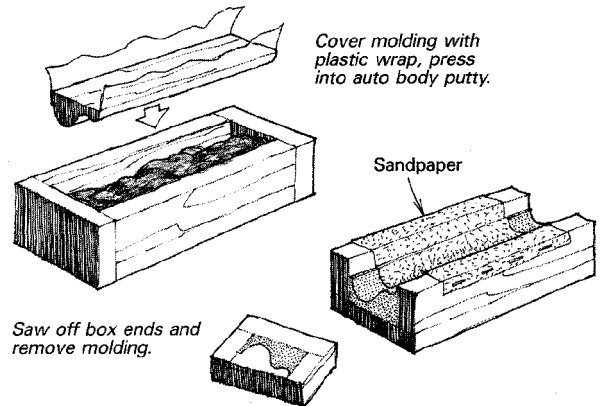

section of molding nearly as long as the box, cover it with thin plastic wrap and press the molding face-down into the body putty so that the air is expelled and the putty takes on the reverse shape of the molding. Hold the molding in place with C-clamps while the filler sets up. After the filler has hardened, bandsaw both ends of the box to free the molding and produce a U-shaped sanding block.

To complete the sanding block, tape sandpaper to a length of molding and sand the interior of the block until it is smooth. Then, staple sandpaper to the sanding block, carefully folding the paper where necessary to fit small corners and narrow beads. —Earl J. Beck, Oak View, Calif.

Quick tip: For spot-oiling in tight places, use an inking pen from an old drafting set. The nibs are now obsolete for drawing, but will take a little oil exactly to the right spot and can be adjusted to dispense it at various speeds, as needed. This method has it all over trying to let little drops run down a fine wire, or similar old tricks. —Robert M. Vaughan, Roanoke, Va.

Locking a pulley on its shaft

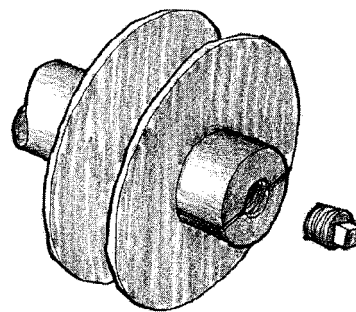

When all else fails, here's how to lock a pulley to a shaft. First, drill and tap the shaft with ¼-in. pipe thread. Split the end of the shaft with a sawcut. Replace the pulley on the shaft and screw a tapered pipe plug in the tapped hole to expand the shaft.

—Douglas M. Ryan, Santa Clara, Calif.

Cheap faceplates

A bit of work will convert an inexpensive, common plumbing floor flange into a lathe faceplate for bowl turning. The biggest problem is that the threads on the floor flange are tapered. You'll have to use a tap in the appropriate size to open up the taper so the faceplate will screw on your lathe's spindle

without binding. After you've opened up the threads, screw the flange on the spindle and check the fit of the hub against the shoulder of the headstock. File the high spots on the hub until it fits flat up against the shoulder. Now, with your lathe running at its slowest speed, scrape the face of the faceplate true with a carbide scraper or an old file ground into a chisel shape. To finish the faceplate, scrape or file the edge. If you use a file, be sure to keep it moving so you won't wear out one spot.

—Robert Kelton, Saranac Lake, N. Y.

Trailer-ball power arm

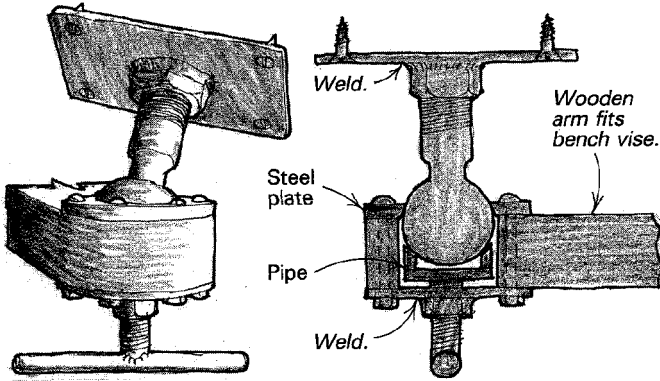

This "poor man's power arm" is invaluable for carvers and sculptors because it lets you swivel and lock a workpiece at any convenient angle. The heart of the fixture is an old trailer ball. Although it certainly isn't necessary, I cut away the shoulder and narrowed the neck of the ball to allow a little more articulation of the joint. The ball rotates in a socket made from steel plates bolted to a wooden arm. The inside of the top plate should be beveled as shown, so it doesn't score the ball. The locking "socket" that the ball fits into is a short piece of 2-in.-dia. pipe, beveled and capped with a disc. A twist on the screw handle will lock this thing up tighter than Dick's hatband.

—John Stockard, Milledgeville, Ga.

Quick tip: I use compressed air to blow out excess finishing oil from joint lines, knots and the like. Otherwise, the surplus oil can gradually bleed to the surface and mar the finish—something that can happen even after hours of wiping and that can be very difficult to remove.

—Joe Carter, Ames, Iowa

Turning accurate tapers

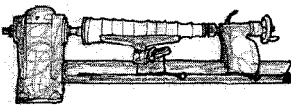

1. To produce a straight taper, turn cone slightly oversize; turn ends exact size.

2. Connect ends with flat.



3. Remount and turn until planed flat just disappears.

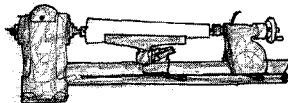

A recent request for a tinsmiths' cone mandrel presented me with the problem of turning, freehand, an accurate taper. The technique I came up with is so simple and effective that I'd like to pass it on to other turners. First, rough out the stock slightly oversize and turn the ends to the final dimensions. Then, with the workpiece in a vise, plane a flat from the large to the small end until there is a straight taper all along. Now, re-center the turning in the lathe and turn the whole piece until the flat edge just barely disappears. The result will be an accurately tapered mandrel.

—Tom Ryder, Sturbridge, Mass.

Measuring wall thickness in carvings

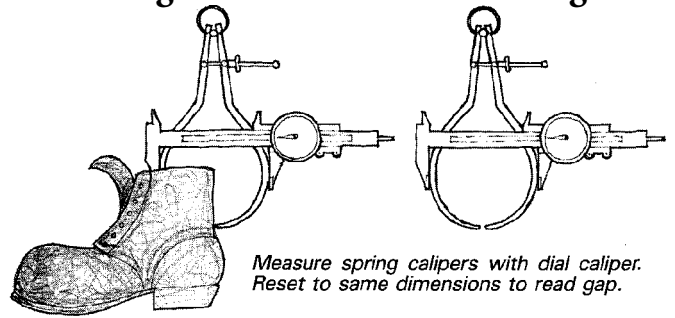

While carving a wooden shoe, I wanted to measure the wall thickness near the ankle. Since none of the measuring tools I had would do the job directly, I used the two-step technique shown in the sketch above.

If you were measuring the thickness of several spots, it would pay to make up a table of wall thicknesses and blade-spread measurements beforehand, so you wouldn't have to reset the calipers each time. I suspect this method would be useful for measuring wall thicknesses on hollow turnings as well.

—Gilbert J. Warmbrodt, St. Louis, Mo.

Quick tip: For desktops and boxes, I get leftover leather from an auto upholstery shop. I use 3M's Spray Trim Adhesive for gluing it down.

—Jon Gullett, Washington, Ill.

Foot-powered hand sharpening

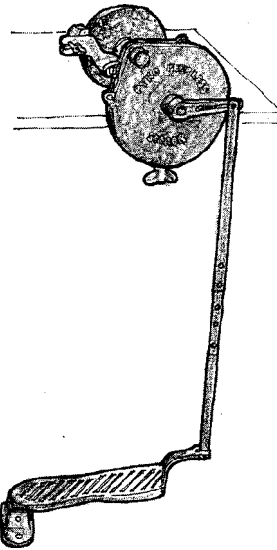

A few weeks back, I walked into a friend's shop and found his new hand grinder in disuse. His excuse was that he just couldn't crank the wheel with one hand and move the tool accurately enough with the other hand to achieve the sensitive, complex grinding required to shape a carving gouge, for example.

Ten minutes later, I'd tied a cord around the handle and to a 2-ft.-long board under my foot to produce a foot crank. Then, not more than a week later, I saw (in the San Joaquin Fine Woodworkers Association's newsletter) a reproduction of a turn-of-the-century advertisement featuring a foot-operated grinder. Bingo—woodworkers

were intelligent once! The old grinder featured a hinged treadle and a steel connecting rod that would certainly have worked smoother than my cord-and-board crank.

—Del Stubbs, Chico, Calif.

Quick tip: Try using cloth-backed belts from a belt sander as replacement abrasive on sanding drums. Cloth outlasts paper several times over.

—Jeffrey D. Walton, Arlington, Ohio

Gluing coopered panels

Here's a fast way to glue up staves for a coopered panel. Apply the glue to as many as a quarter-circle's worth of staves (if the panel is bigger than a quarter-circle, glue it up in sections). Then, lay the staves edge-to-edge, outside-up, on a clean flat surface. Apply several strips of strapping tape (the kind with fiberglass filaments running the length) across the staves, taking care to keep the stave edges in close contact. Now, using

two pipe clamps on the inside of the curve, apply light pressure to close the gaps and hold the panel in its curved shape until the glue sets. The procedure sounds too easy, but I've made strong panels with invisible glue lines inside and out using the method. —Gregory V. Tolman, Evergreen, Colo.

Quick tip: I use small magnets stuck on my drill press and various other tools to hold Alien wrenches, chuck keys and other small parts. Another method is to cut a short length of plastic tubing and tape it vertically to the tool—the wrench or chuck key can then be slipped into the tubing for on-hand storage. —Jack Rosenfield, Lakewood, Colo.

Making tenons on chair rungs

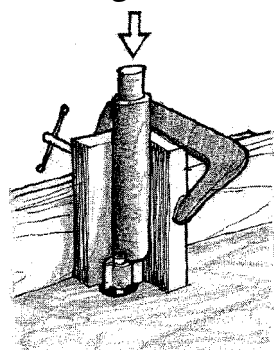

Here's how to use your router table to produce tenons on the end of chair rungs, quickly and accurately. First, chuck a rabbeting bit into the router and raise it until the bit's bottom is even with the top of the router table. Locate a V-block near the bit to produce the diameter desired, and clamp the V-block in place using the router table's fence. Then, holding the rung firmly with one hand, lower it into the rotating bit. Rotate the rung with the other hand in a counterclockwise direction. The result will be a clean and uniform reduction of the dowel diameter. To reduce splintering, take several small bites of $\frac{1}{8}$ in. or less. —David J. Langley, Corvallis, Ore.

Vacuum screening ramp

Sweep shavings up ramp; slots screen out pieces too large for vacuum.

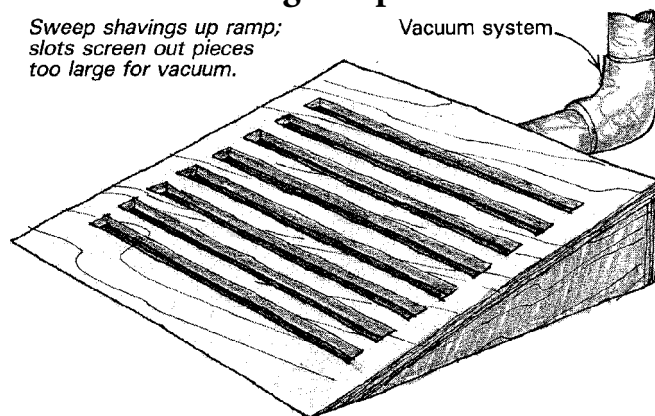

Even in shops with efficient dust-collection systems, there are always piles of sawdust and shavings that must be swept up with a broom. Here's a handy screening ramp to speed up your cleanup. With $\frac{1}{2}$ -in. plywood, fabricate a wedge-shaped box with 1-in. slots cut into the top. Attach the ramp to your vacuum system through a hole in the back. Now, simply sweep your piles up the ramp. Any piece too large for your dust collector's digestive system will be filtered out by the slots.

—Ralph Bell, Ashford, Wash.

Methods of Work buys readers' tips, jigs and tricks. Send details, sketches (we'll redraw them) and photos to Methods, Fine Woodworking, Box 355, Newtown, Conn. 06470. We'll return only those contributions that include an SASE.

Home for tablesaw accessories

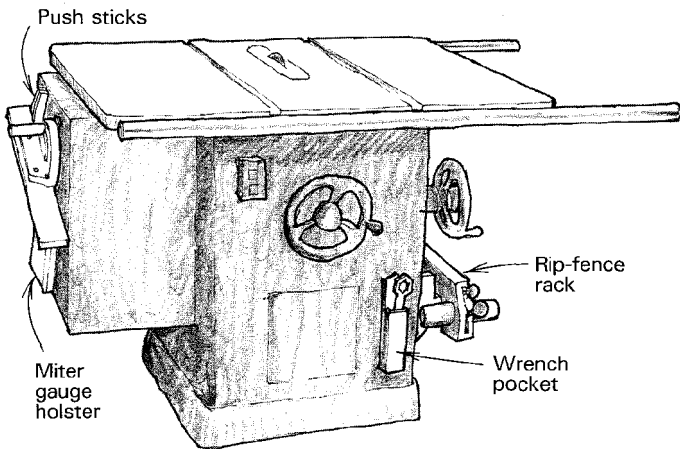

The last time I used my tablesaw on a project that required both crosscuts and rips, I couldn't find a place to park the rip fence and miter gauge to keep them safely close at hand. Plus, the blade-changing wrench was always lost in the shop clutter, and my push sticks constantly wandered out of reach—just when I needed them most.

To resolve these problems, I decided to make homes for all my tablesaw attachments by building simple scrapwood holsters and racks at various places on the saw. The sketch above illustrates the idea.

—Fred H. Sides, Mt. Kisco, N. Y.

Quick tip: I've been carving for more than 50 years, and I use a rubber hammer instead of a wooden mallet. The blow is more controllable and the rubber won't damage your tool handles (frayed tool handles cause blistered hands). For very little money, you can get a set of four sizes at your local auto-body supply store.

—Ford Green, San Antonio, Texas

Simplified captured-nut system

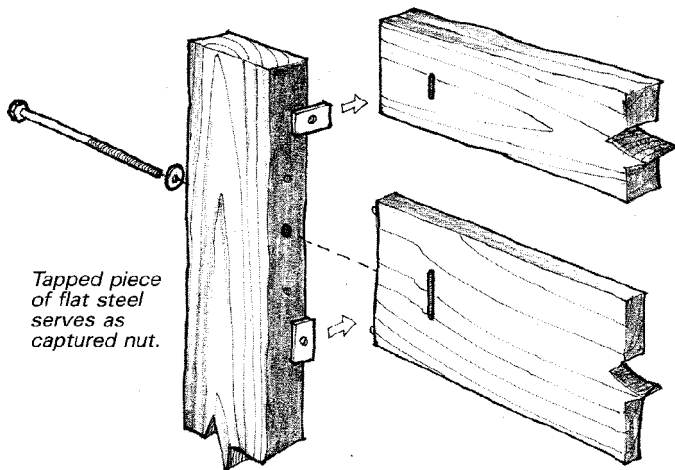

I'm familiar with the principle of barrel nuts—short lengths of round steel rod, drilled through and tapped—used as captured nuts to join stretchers to frames. Unfortunately, when I tried to manufacture them, I quickly discovered that the metalworking tools and skills required were beyond my meager means.

Instead, I returned to my own system, shown in the sketch. It uses a piece of flat, 1½-in.-long, ¼-in.-wide steel that is drilled, tapped and fitted into a routed slot in the stretcher.

The rectangular shape of the "nut" allows maximum purchase, and you can vary its orientation as shown, depending on the thickness of the frame members.

—Chuck Lakin, Waterville, Maine

Homemade rubber motor mount

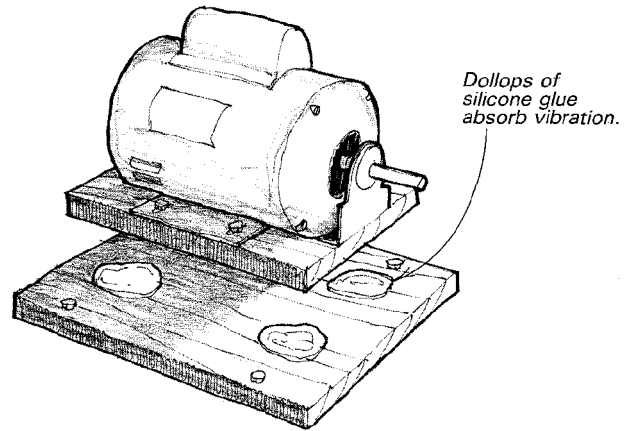

A rigidly mounted motor can set up annoying vibrations and cause an entire machine to buzz. Here's how to mount the motor on rubber, which will usually cure any vibration problem. Simply glue two plywood motor-mount boards together with four big dollops of silicone-rubber adhesive. (The rubber seems to adhere better if the boards are varnished first.) To keep the rubber from squeezing out, place ¼-in. spacers between the two boards until the rubber cures. Now, screw the motor to the top board and fasten the bottom board to your machine base. The rubber will insulate the machine from vibration.

—Bill Webster, Chillicothe, Ill.

Improved glue spreader

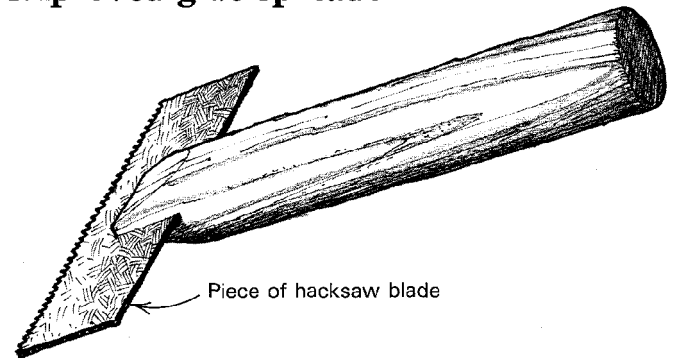

I've seen several ideas for glue spreaders in "Methods of Work," all of which, in my opinion, have a serious drawback: Their smooth edges make it difficult to spread a consistent amount of glue over a broad surface, because the slightest variation in pressure varies the amount of glue on the surface.

To avoid this problem, I use broken or worn-out hacksaw blades for glue spreaders. The toothed edge works just like a tile layers' notched trowel, leaving a consistent layer of glue wherever it's spread. To make a handle for the spreader, I hacksaw a short slot in the end of a dowel scrap and press the section of blade into the slot.

—David W. Engel, Joliet, Mont.

Quick tip: If you use uncoated "black" pipe in your pipe clamps, the metal will react with aliphatic-resin glue to produce a deep purple stain on your project. To remedy this problem, simply spray the pipe with several coats of polyurethane varnish to seal it.

—Keith Henderson, Richfield, Minn.

Tinting glue

Since most carpenters' glues dry almost colorless, any squeeze-out is hard to see until you apply the stain and see that telltale white spot. To solve this problem, tint your glue

with ordinary food coloring. A few drops of red or green will make any squeeze-out highly visible and easy to sand off. If your taste in color is more conservative, mix equal amounts of red and green to make a pleasant brown.

—Donald F. Kinnaman, Phoenix, Ariz.

Stikit to the rescue

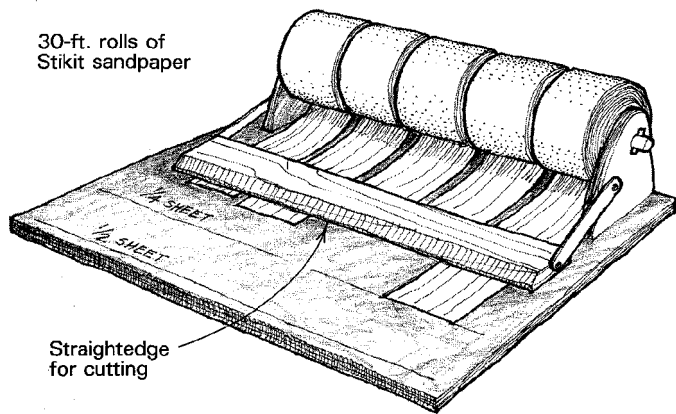

I read Ben Erickson's letter expressing his displeasure with the Makita B04510 Sander's thumb-torturing, paper-clamping arms (*FWW* #62). I also own a Makita sander, and agree with Erickson's low opinion of the clamping system. I just hope the garbage truck hasn't already hauled away his sander, because when the sturdy little machine is coupled with 3M's new Stikit paper system, it's a winner.

Stikit is a new adhesive-backed sandpaper that not only eliminates paper-clamping problems but also makes paper changing a snap. The product was developed expressly for orbital sanders, and is available in 30-ft. rolls in several grits, from 80 to 220. To use the paper, you first install a special pad on the bottom of your sander. Then, you simply press a sheet of the paper on the pad and you're ready to go. When the paper is worn, you just peel it off and put a fresh sheet on. The Stikit system not only makes changing paper easier—it also makes the sheets last longer since there are no bends to tear. Rolls of Stikit paper—along with special conversion pads that can be applied to any orbital sander—are available from Trend-Lines, Inc. (375 Beacham St., Chelsea, Mass. 02150) or Woodworker's Supply of New Mexico (5604 Alameda N.E., Albuquerque, N.M. 87113).

To dispense the paper easily, I built a plywood and dowel rack like the one shown in the sketch. A fold-down straightedge of wood or metal holds the paper and provides an edge for cutting off the correct length with a utility knife.

—Voicu Marian, Alliance, Ohio

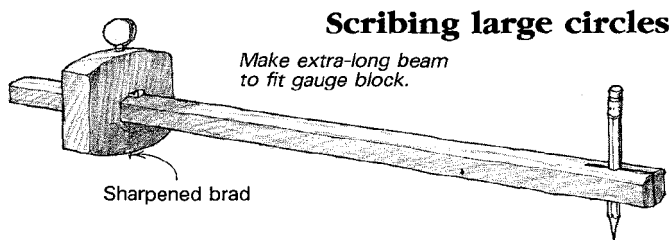

Here's an inexpensive and easy-to-make alternative to trammel points for scribing large circles or arcs. First cut a long hardwood beam to fit the hole in your marking gauge. Make a vertical sawcut in one end of the beam, and drill a $\frac{1}{32}$ -in. hole through the cut to hold a pencil. Now, drive a brad in the bottom of the gauge to serve as a compass point, install the beam in the gauge block and you're ready to scribe a circle as big as the beam.

—Gregory V. Tolman, Evergreen, Colo.

Low-cost airbrush

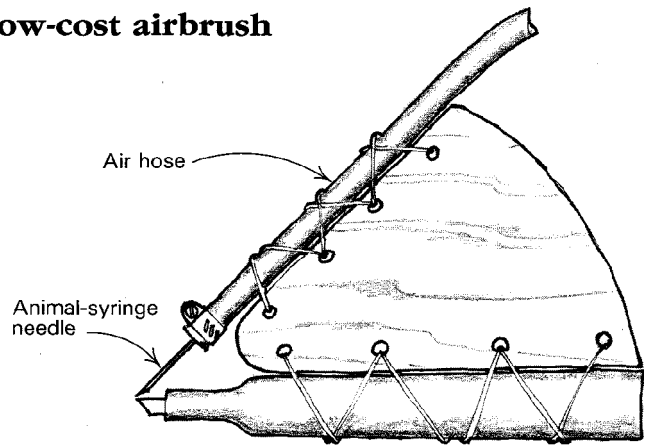

You can make an effective airbrush by using a needle from a No. 11 animal syringe and a common felt-tip marker. As shown in the sketch, a simple wooden block with rubber bands holds the tip of the marker in the fine airstream that passes through the needle. For the air supply, use a shop compressor regulated at from 15 to 30 psi. I recommend the use of an electric solenoid to start and stop the air with a minimum of bleed-off. I use the airbrush to detail fishing lures in a rainbow of colors.

—Fred J. Steffens, Monroe, Wis.

Miter clamping cleats

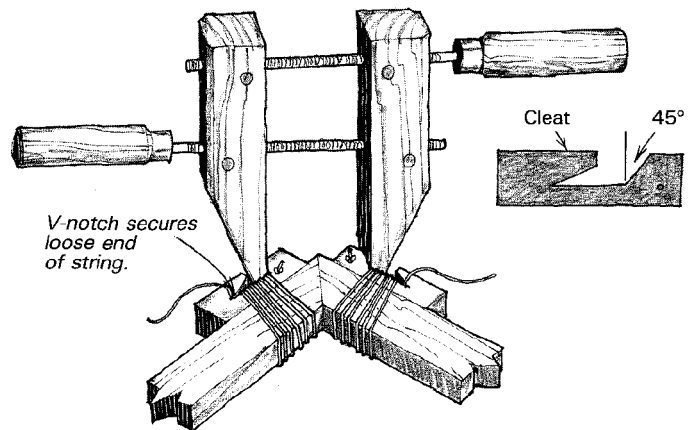

Here's an easy way to attach clamping cleats for gluing mitered joints. You'll need eight of the clamping cleats, which can be cut out on the bandsaw in just a few minutes. The cleats can be made up in any size using about the same proportions as those in the sketch. They should be about the same thickness as the stock being glued.

To use the cleats, set one in position near the corner to be glued and wrap the attached string around the frame six or eight times. Secure the loose end of the string in the V-notch of the cleat. Repeat with other glue cleats until you have a pair installed at each corner. Now, pull the cleats together with clamps. The cleats will move a fraction of an inch at first and the string will creak as it takes the strain. But, soon, the cleats will hold tight, giving your clamp a perfect perch to draw the joint tight.

—David Wardale, Merced, Calif.

Two-faced sanding slab

I suspect many among us like to sand small pieces of wood by rubbing them back and forth on a whole sheet of sandpaper, finger-pressed against the top of a workbench or the flat table of a handy woodworking machine. And just as many of us know that it's only a matter of time before OOPS...we slip

and that fresh sheet of sandpaper is wrinkled or torn. If this sounds familiar then, between projects, make this versatile sanding slab from a piece of scrap and a couple of inner-tube ribbons. The device firmly clamps a full sheet of sandpaper for sanding, but allows easy replacement when it's worn out. While you're at it, make two slabs so you can have four different grades of sandpaper at the ready, simply by flipping the slabs.

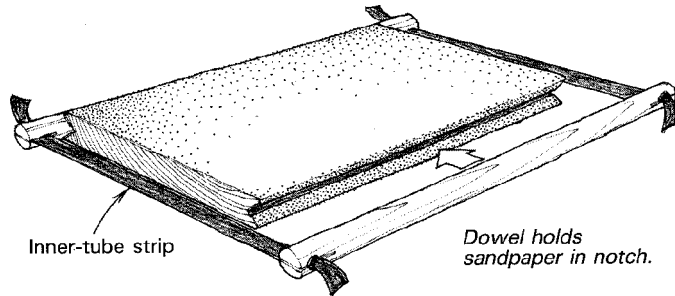

Size the slab as long as a sheet of sandpaper but about an inch narrower so that you can fold the sandpaper's edges over into the V-grooves and hold them with the tensioned dowels. The thickness of the slab is not important. No doubt, $\frac{3}{4}$ in. stock and $\frac{1}{4}$ in. doweling would work just fine.

To use the slab, simply fold a sheet of sandpaper over its face, snap the tensioned dowels into the V-grooves and start sanding. Here's a hint for mounting two sheets at once: Tack two sheets of sandpaper in place temporarily with masking tape before snapping the dowels into the V-grooves.

—Frank Schuch, La Mesa, Calif.

Dividing a circle

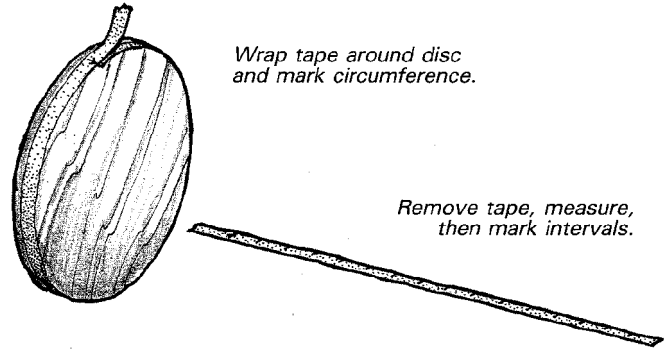

Here's an accurate way to lay out equally spaced intervals on the circumference of a circle—without the aid of dividers, protractors, indexing heads or geometry skills. Simply wrap masking tape around the circle and mark where the tail of the tape overlaps the starting point. Remove the tape and fasten it to a flat, clean tabletop. Now, measure the distance between the marks to get the circle's circumference and divide this distance by the number of intervals you want. Next, lay out the intervals on the tape, reapply the tape to the workpiece and mark each interval's location on the workpiece circumference by piercing the tape with an awl.

—Randall Bishop, Christiansburg, Va.

Methods of Work buys readers' tips, jigs and tricks. Send details, sketches (we'll redraw them) and photos to Methods, Fine Woodworking, Box 355, Newtown, Conn. 06470. We'll return only those contributions that include an SASE.

Sawing duplicate pieces on the bandsaw

I had experimented with various bandsaw techniques for sawing duplicate pieces, but I was dissatisfied with the results and the lack of flexibility. As a result, I developed this simple fixture. It lets you duplicate a pattern quickly and accurately, provided the curves aren't too abrupt for the blade to follow. Another advantage of the fixture is that you need only one pattern to produce various-sized duplicates.

The fixture evolved from a common circle-cutting jig that uses an auxiliary table clamped to a bandsaw table. The table is simply a piece of ¼-in. Formica-covered plywood with a ¼ in. groove routed in the top (the centerline of the groove is aimed at the cutting edge of the blade). The rest of the fixture consists of a guide pin, a sliding pivot pin and a spacer. The guide pin and the sliding pivot pin are both ¼-in. dowels pressed into small blocks sized to fit the groove.

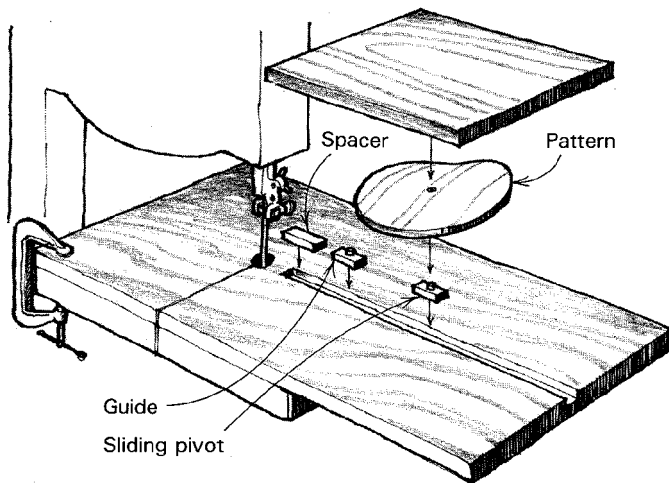

To use the fixture, first cut a pattern an inch or two smaller than the finished size of your workpiece and drill a pivot-pin hole near its center. Next, place the guide pin in the groove at an appropriate distance from the blade. The distance from the guide pin to the blade will determine the enlargement of the finished duplicate over the pattern. Fix the guide pin at this distance by placing one or more spacer blocks between the guide and the end of the groove.

Now, attach a blank to the pattern with brads, two-sided tape or hot-melt glue. Fit the blank/pattern assembly over the pivot pin and cut the duplicate by rotating it while applying gentle pressure toward the guide pin. The pivot pin will slide back and forth in the groove as the pattern follows the guide pin. Generally, the stock is too large to allow the pattern to contact the guide pin at first. In this case, simply turn the pattern and feed the stock into the blade until the pattern touches the pin.

The fixture is useful for many applications. Curved pieces—such as the back of a crowned chair—can be ripped quickly and easily. If the fixture is adapted to a scroll saw, it can be used to cut elliptical picture frames. With minor modifications, the setup can also be used to cut circles.

—Peter J. Cranford, Windsor Junction, Nova Scotia

Making twelve-sided turning blanks

It's common practice to rip the corners from square turning stock, making it octagonal, in order to reduce the amount of material to be roughed off in the lathe. It's just as easy to produce a twelve-sided turning blank, which requires even less stock removal in the lathe and doesn't require racking the saw blade over to 45°, where my tablesaw, at least, doesn't behave very well.

First, set the tablesaw blade at 30° away from vertical. Set the

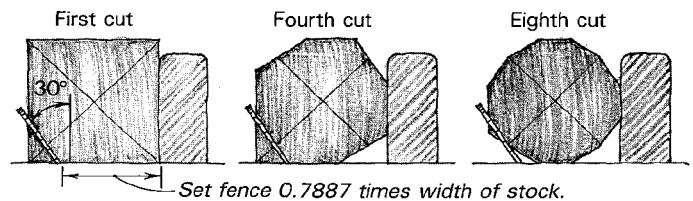

rip fence at 0.7887 of the stock width from the blade. This setting can be approximated accurately by taking ¾ in. plus ½ in. for each inch of face width. Mark both ends of the stock with an X, as shown in the sketch, so as to be able to keep track of which corners to cut off. Rip the corners from the square, turning the stock 90° clockwise each time if your fence is to the right of the blade. Now turn the stock end-for-end and repeat the process keeping the original faces, which are now not the widest ones, against the fence and saw table.

A 10-in. saw will handle a 7½-in.-thick blank. The procedure is inadvisable for stock less than 1½ in. wide, because the faces become too narrow to guide safely against the fence and table.

—Warren Miller, State College, Penn.

Quick tip: I make router subbases out of ⅜-in. Plexiglas, to increase visibility.

—Jerome Crawford, Durham, N.H.

Powering other tools with a tablesaw

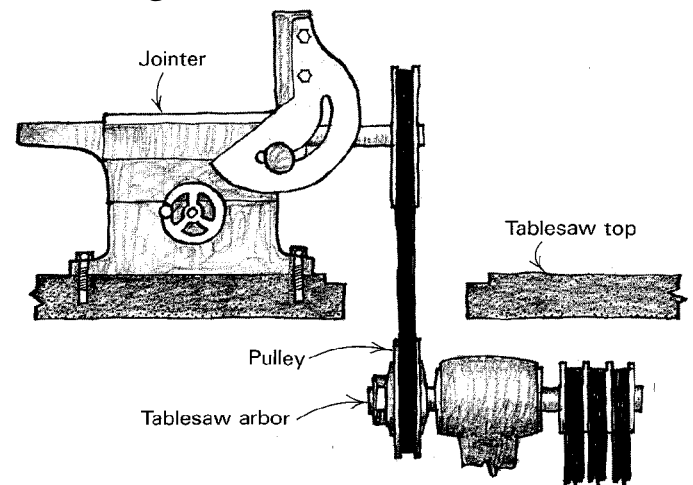

If you work in a small shop as I do and space is at a premium, here's how to drive another tool, a small jointer for example, with your tablesaw's motor. First slip a pulley on the saw's arbor and tighten the arbor nut as you would with a sawblade. As with any tool setup, be sure to size the pulley to drive your tool at the proper speed. Place the jointer on the saw table and clamp or bolt it in place. If you plan to use the arrangement often, you may wish to drill and tap fastening holes for the jointer right into the saw table. Next, slip a belt over the pulleys and lower the saw motor until the belt is tensioned. The whole arrangement takes no longer to set up than any other tablesaw accessory, and you save the price of a motor and gain a little space in your shop as well.

—Luc Mercier, Laval, Que.

Blade covers

After spending several hours honing a new 3-in.-wide fishtail gouge, I considered fabricating a special blade cover to protect the cutting edge. A better idea came to me as I paged through a mail-order supply catalog and spied a product called Plastic Dip, normally used for coating plier handles.

Here's how I made a blade cover with Plastic Dip. First, I spread some Vaseline on the blade so the plastic wouldn't stick

to the metal. Then, I dipped the blade in the plastic once a day for four days. After four applications, I trimmed the top of the dip and pulled at it gently. My newly made blade cover came off with a thwack! The dip had molded itself perfectly to the blade, and the Vaseline allowed easy removal. I couldn't ask for a tougher material. Plastic Dip is sold by Leichtung (4944 Commerce Parkway, Cleveland, OH 44128) for about \$8 per can.

—Carl Hungness, *Speedway, Ind.*

Improved sharpening-stone box

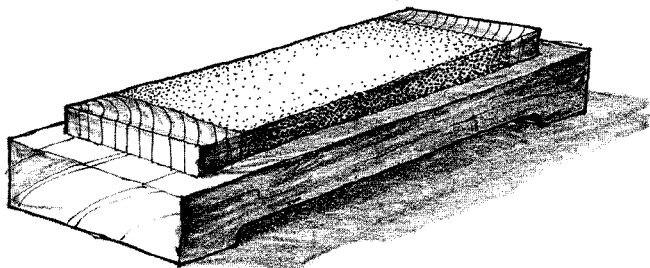

By mortising two endgrain blocks into your sharpening-stone box (one on each end of the stone), you'll provide support for longer sharpening strokes—the tool won't skip abruptly off the edge of the stone at the end of a stroke, nor do you risk catching the edge on the end of the stone at the beginning of a stroke. Longer strokes will reduce wear in the middle of the stone and greatly increase the stone's life.

—James Gauntlett, *Boise, Id.*

Quick tip: Tapping a hole in cast steel, and feeling too lazy to get my tapping fluid, I grabbed a convenient bottle of Teflon-based lubricant. The tap turned in just like a bolt into an already-threaded hole! I've since tested the fluid to both drill and tap holes in mild steel, brass and aluminum, with good results in all.

—Gordon Mulholland, *Streator, Ill.*

Making long dowels

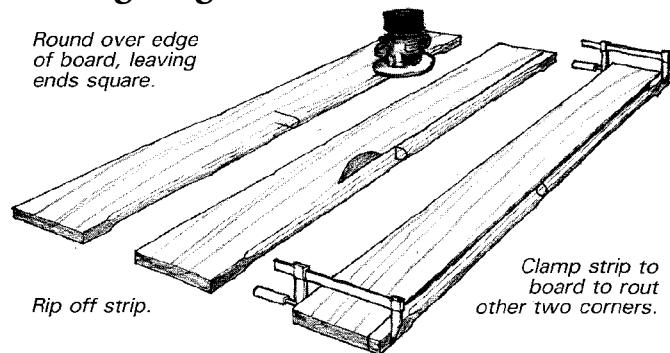

I needed a $\frac{3}{4}$ -in.-dia. oak dowel more than 6 ft. long to use as a curtain rod. Unable to find a source of supply, I came up with a method to make the dowel in my shop without a lot of effort. First, I rounded the edges of a 7-ft.-long, $\frac{3}{4}$ -in.-thick oak board with a $\frac{3}{8}$ -in. corner-round bit in my router. I didn't round over the first and last 6 in. of the board because I knew I'd need the square ends for a clamping surface later. Moving the board to the tablesaw, I set my fence at $\frac{3}{4}$ in. and ripped off the rounded edge. I then flipped the stick over, clamped it back to the board with three quick-action clamps (for stability) and rounded the top and bottom edges again to produce a dowel. Of course, I had to reposition the middle clamp to finish the rounding. When I trimmed off the two square ends, I had my long dowel, ready to scrape, sand and finish.

—Phil Lisik, *Hemlock, Mich.*

Double bifocal shop glasses

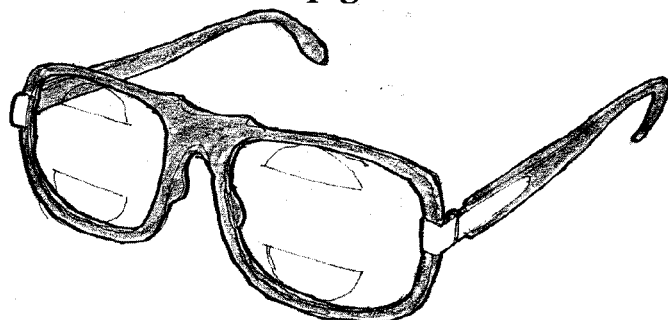

Last year, it finally became necessary for me to begin wearing bifocals. The close-up area of the lens worked fine—as long as the work was below me. But the glasses didn't help at all if I was doing close or detailed work *overhead*. So, I had my optician make me a pair of shop glasses with bifocal areas on both the top and the bottom, as shown above. The particular design is known as Double D28, Occupational Segments. The glasses have greatly improved my enjoyment of woodworking.

—Rod Goettelmann, *Vincentown, N.J.*

Quick tip: Many woodworking glues are strongly fluorescent. If you have an ultraviolet lamp, you can use its ghostly light to spot glue residue that otherwise would come back to haunt you later.

—Allan E. Gilmore, *Sacramento, Calif.*

Roller-stand adjustment revisited

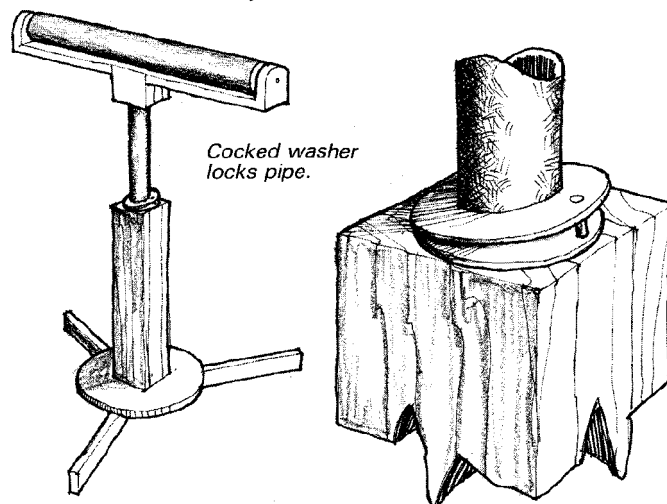

My three-legged roller stands are similar to Tim Anderson's (*FWW#60*). But I have substituted a 1-in.-dia. steel pipe in place of Anderson's sliding dowel, and I use a cocked washer mechanism for adjustment and locking. It's the same idea found on many pipe and bar clamps. To make the adjustment mechanism, first locate a couple of steel washers with holes about $\frac{1}{8}$ in. larger than the outside diameter of the pipe. Rivet a $\frac{1}{2}$ -in.-long steel bolt to one side of one washer. The bolt will cock the washer against the pipe and automatically lock the roller assembly at any height. The second washer prevents wear on the stand. To release the mechanism, simply lift up on the low side of the top washer.

—Ingwald Wegenke, *Montello, Wisc.*

Lubricating sealed bearings

If you ever have a power tool with a noisy sealed bearing, here's an unorthodox but effective way to lubricate it. Place the dry bearing in a can of oil, and place the can inside a bell jar on a vacuum pump. Switch the pump on and watch the air

bubbles come to the surface of the oil. When the bubbles stop rising, turn the pump off. Normal air pressure will force the oil into the sealed bearing.

Some of you are probably asking where you can get a vacuum pump and bell jar. Check with the head of your local high school's science department. If you're a tax-paying resident of that town, you'll most likely be allowed to use the school's equipment.
—William Warner, York, Pa.

Steady rest for baseball bats

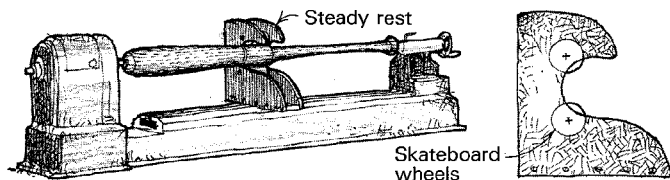

For years, the eighth graders in my woodworking class have wanted to turn baseball bats. I've always put them off because the small diameter of the bat's handle invariably results in whipping and chattering, especially at the hands of an inexperienced turner. I licked the problem by making the steady rest shown here out of skateboard wheels, threaded rod and a couple of scraps of hardwood. The urethane plastic skateboard wheels can be bought for less than \$15 a pair.

To use the steady rest, turn a cylinder, then tighten the steady rest in place with both wheels riding ahead of the handle. Turn the bat to shape, except the area right near the steady rest. My students spokeshave this area off, then sand and finish their bats.
—Paul Damato, Morristown, N.J.

Fancy eyes for pull toys

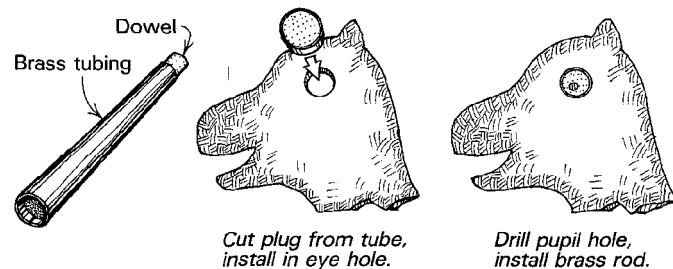

Here's how to make eyes for wooden-animal pull toys that give them an animated and professional touch. First, drive a 3-in. dowel into a 3-in. length of brass tubing with the same outside diameter as you've chosen for the eye. If you round the nose of the dowel and proceed carefully, you should be able to drive the full length of the dowel through.

Next, cut a short plug off the brass-encased dowel and epoxy it into an eye hole you've drilled in the toy's head. When the glue has set, drill an off-center pupil hole near the bottom edge, and tap in a piece of brass rod. Use a file and sandpaper to bring the eye flush with the toy's head. A drop of lacquer over the entire eye will prevent the brass from tarnishing and preserve the gleam. Brass tubing and rods are available in various sizes at most hobby stores.
—Mark DiBona, Kensington, N.H.

Methods of Work buys readers' tips, jigs and tricks. Send details, sketches (we'll redraw them) and photos to Methods, Fine Woodworking, Box 355, Newtown, Conn. 06470. We'll return only those contributions that include an SASE.

Making fluted panels on the tablesaw

When I needed two 7-ft.-long fluted panels for the front entrance of my house, I made this simple angled fence and cut the flutes on my tablesaw. The fence is simply a wedge-shaped piece of plywood screwed to a plywood channel that press-fits on the rip fence. The angle of the plywood to the blade will determine the shape of the flutes, with a small angle producing deep, narrow flutes and a larger angle producing shallow, wide flutes. I found that an angle of 13° was about right for this particular job.

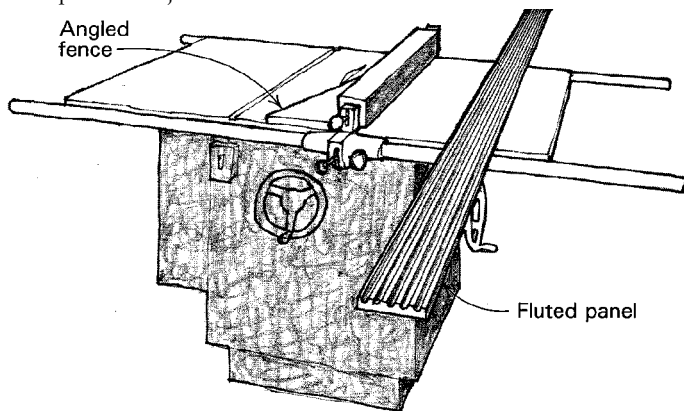

To cut the fluted panels, fix the angled fence on the rip fence and set the blade depth at about 1/8 in. It will take four passes, raising the blade 1/8 in. each pass, to cut the flute to its final depth of 1/2 in. After one flute has been completed, move the rip fence over, lower the blade and start another.

—Wayne A. Kulesza, Chicago, Ill.

Quick-change countersink

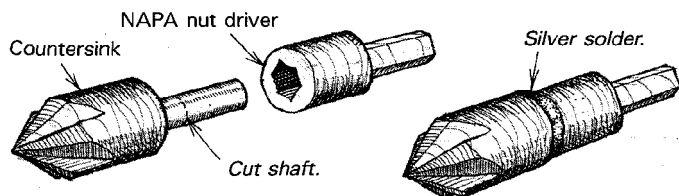

I use a lot of countersunk drywall screws in my cabinet work, but I couldn't find a countersink with a six-sided shaft to fit my magnetic bit holder. As a result, I wasted a lot of time chucking back and forth between countersink and driver.

To solve this problem, I made a fast-change countersink by silver-soldering the shortened shaft of a common countersink into a NAPA nut driver. The driver's shaft easily slips into the magnetic bit holder. —Harry Sommers, Coeur d'Alene, Ida.

Turning spheres

While chatting at a meeting of the Guild of Oregon Woodworkers, I learned that I turn spheres differently than do most other turners. First, I turn a short cylinder with the grain running along the long axis. I turn the cylinder slightly longer than the diameter of the finished ball, then mark around the center of the cylinder with a pencil. Next, I square across one end and down each side to give me the location of two new turning centers. I chuck the cylinder in the lathe on these new centers and hang a light behind the turning. With the light turned on and the workpiece spinning in the lathe, the outline of a phantom sphere appears through the workpiece. I turn to this phantom line with a skew, being careful to avoid kickback, then sand and finish. If you don't have much experience with a skew, you may want to do most of the work with a gouge, then finish carefully with a skew.

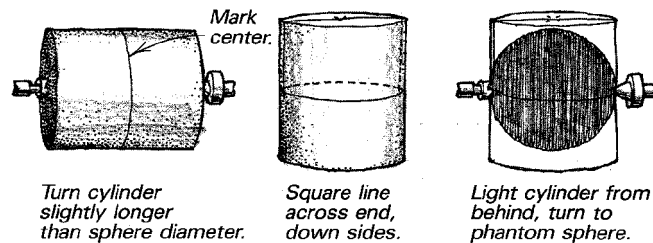

This approach leaves tiny defects that can be filled and sanded where the centers have dented each side. Reduce these defects by using a small spur center and a ball-bearing center.

—Bill Fox, Salem, Ore.

Jig for sliding dovetail housings

I use a simple but effective jig to cut housings for sliding dovetails in drawer construction. The jig consists of an L-shaped shelf, a fence to guide the router and a spacer board screwed to the fence from the bottom. The jig is clamped to the front of the workbench from underneath with pipe clamps and is carefully adjusted so the height of the shelf matches the thickness of the drawer stock.

The jig is designed so that housings are cut 1/2 in. from the end of the workpiece. If necessary, adjust the size of the spacer to locate the housing farther from the edge. The grooves for the drawer bottom are cut in the drawer front and sides before the jig is used.

To use the jig, butt two sides up to the stop as shown, with the grooves at the far side of the drawer stock. Move the router in from the front of the jig, and stop the cut at the groove. To cut the housings in the drawer front, place the front so it faces in the opposite direction, with the bottom groove in front. Rout through the groove, stopping the cut for the housing at the desired distance from the top edge (usually 1/2 in. or so). This way, the sliding dovetail is not exposed at the top edge of the drawer's front.

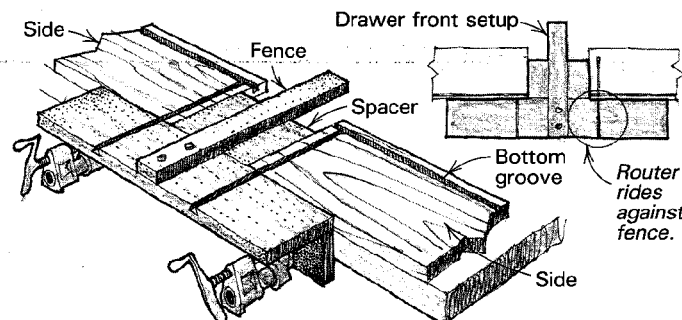

To rout the male dovetails, I use a tall fence on my router table with the router attached to the back of the fence and the bit running parallel to the table. I recommend cutting one side of the dovetail on all the pieces, then resetting the fence and cutting the other side with the same face against the table as before. The principle of always working relative to one face will ensure that all dovetails will be the same size.

—Barrie Graham, Arundel, Quebec

Velvet drawer bottoms

The standard approach to lining the bottom of jewelry box drawers is to cut a piece of felt to size and glue it in place. I prefer velvet's rich feel over felt, but the cut-and-paste approach doesn't work as well with this material.

To solve the problem, I install the velvet bottom before assembling the drawer. I apply a light, even film of Titebond or Elmer's glue on an oversized plywood drawer bottom. I lay the

velvet on the glue-wetted surface, smooth out the wrinkles and—when the glue has dried—cut the bottom to size. If you cut the bottom to size before the glue sets, the wet threads in the velvet tangle in the saw and create a mess.

The rest of the assembly is as usual, except you need to cut the bottom grooves in the sides of the drawer wider by $\frac{1}{8}$ in. or so to accommodate the extra material.

—David Miller, Annville, Pa.

Quick tip: I store assorted grits of sandpaper in a large, alphabetically indexed, accordion-type office file folder. The pockets are easily re-labeled to indicate various grit sizes, and are large enough to accept a full pack at a time. They even hold 10-in.-dia. sanding discs.

—Rod Short, Anchorage, Alaska

Drilling centered holes in dowels

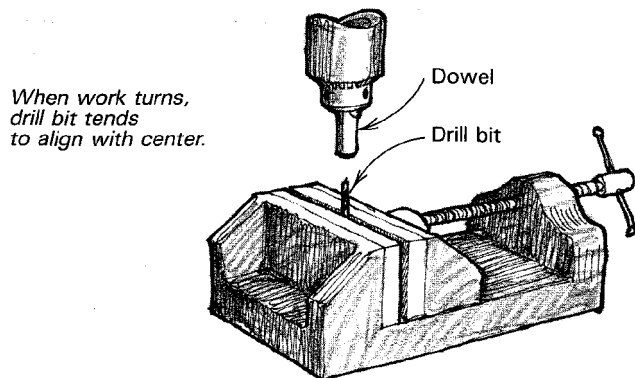

When you need to drill a longitudinal hole in a small dowel such as Jeris Chamey's box hinge (FWW #62), try this. Chuck the dowel in the drill press and hold the drill bit in the drill-press vise. When you lower the dowel on the bit, it will self-center and provide a quite accurately centered hole.

If your drill-press vise doesn't have a vertical slot milled in the jaws, here's how to align the bit. First, tighten the fluted end of the bit in the chuck with just enough pressure to hold it without damaging the flutes. Then, grip the shank of the bit with the vise. Release the chuck and the drill will be vertically aligned, ready to drill the workpiece.

—Bob Grove, Portland, Ore.

Quick tip: When using a saber saw on a delicate surface, such as when installing a sink in a countertop, the saw's base can cause scratches. As a cure, I made two removable, soft skids for the base of my saw, using magnetic strips with felt glued to one side.

—Marco Väis, Montreal, Quebec

Making tight leg tenons

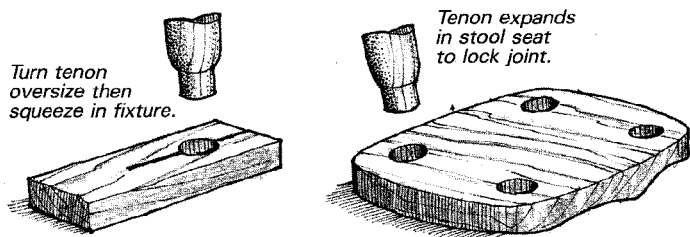

I make Windsor stools with legs that have tenons turned at the top to fit blind holes bored in the stool seat. These leg joints take a lot of stress, so I take pains to ensure the leg joint is tight. First, I turn the tenon slightly oversize, so its diameter is about $\frac{1}{64}$ in. too big for the hole. Then, before assembly, I compress the tenon with the fixture shown in the sketch, so it

fits into the hole in the seat. Later, because of the moisture in the glue, the leg will expand and lock itself in the socket.

The compression fixture is a maple board drilled with the same size hole as the tenon, then slotted halfway with a saw-kerf. To compress the tenon, I insert it in the fixture and squeeze the fixture in a vise. I rotate the leg 90° and squeeze it with the vise again. Although the leg's diameter may only be reduced about $\frac{1}{64}$ in., it should be sufficient. It's advisable to score the tenon lengthwise before gluing to allow excess glue to escape.

—John Taylor, Golcar, Huddersfield, Eng.

Quick tip: To prevent sawdust and chips from flying all over the shop, I mount old roll-up window shades to the ceiling at strategic locations to act as deflection shields. Cleanup is easy with broom and shovel.

—Don Henschel, Shelton, Conn.

Turning splatter guard

There are several advantages to finishing a turned bowl or spindle on the lathe. But one big disadvantage is that the finish sprays all over the lathe and the wall behind. When I finally got tired of taping newspaper behind and on the lathe, I enlisted the help of Dr. Bill Riddle, the metals instructor at our school, to build the finishing shield shown here.

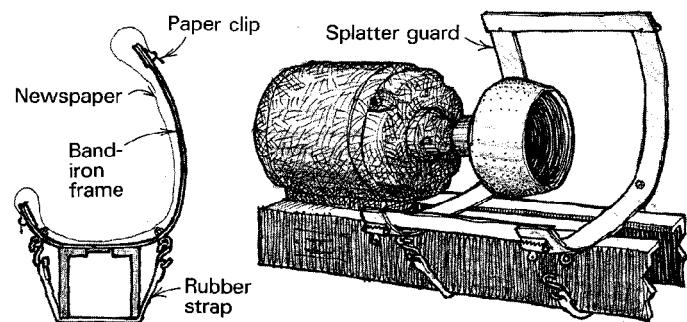

We welded together pieces of $\frac{1}{8}$ -in. by $1\frac{1}{2}$ -in. band iron for the shield's frame. The piece of band iron welded to the bottom serves as an index to locate the shield between the lathe's ways. We riveted a No. 2 Boston paper clip to each corner to hold a sheet of newspaper spread inside the shield. Finally, we attached two rubber tie-down straps to the rear of the shield. These straps are pulled under the lathe bed and hooked into rings on the front of the saddle to cinch the shield down.

—Jerry Brownrigg, Alva, Okla.

Quick tip: If you make your own knives and chisels, an excellent source for steel is broken sword blades. If there's a fencing club nearby (perhaps at the YMCA), ask them to save their broken foil blades for you. The blades are excellent steel and work well for small tools.

—Bob Vernon, Ann Arbor, Mich.

Hiding hairline cracks in wood

Like many other craftsmen, I've been through the mill trying to find a suitable material for patching cracks, holes and other imperfections in wood projects. I finally hit upon a terrific solution: acrylic modeling paste—the kind artists use for thick, built-up effects. It's available at any well-stocked art supply shop. You can color the paste to match any wood, using commonly available acrylic artists' paints. The paste will go into hairline cracks and can be piled up about $\frac{1}{8}$ in. thick without cracking. It carves, sands and machines like wood. What's more, it will take any finish.

—John Stockard, Milledgeville, Ga.

Here's how to repair and fill a hairline crack that mars an otherwise usable piece of wood. You'll need fast-penetrating cyanoacrylate glue and extra-thick cyanoacrylate glue. Both are

commonly available at hobby and model shops. If the crack is closed, hold it open with a knife. Apply the fast-penetrating glue first, which will be sucked deep into the crack by capillary action. Then apply the heavy-bodied glue, which will follow the thinner glue into the crack. Open and close the crack a few times to distribute the glue. If the crack is open, force wood dust into it with a spatula or an artists' palette knife and mix it with the glue. Clamp the wood if needed. Two hours is enough drying time. —*John W. Wood, Tyler, Tex.*

Quick tip: Rubber fingertips, available in several sizes at office supply stores, are ideal finger protectors when a project requires hand-sanding. In addition to saving skin, they help the sandpaper last longer and prevent oily fingerprints on light-colored woods. —*Dennis Schorpp, Monroe, Wash.*

Cutting felt circles

Recently, I made a jewelry chest containing a number of trays with compartments created by drilling spaced holes with a $2\frac{1}{8}$ -in. Forstner bit. This left me with the problem of cutting numerous $2\frac{1}{8}$ -in. circles from sheets of self-adhesive felt for lining the cavities. I solved this problem by replacing the pencil in my 8-in. bow compass with a standard X-Acto knife. With this setup, I was able to easily cut the felt circles in a few minutes. —*Douglas B. Hammer, Solon Springs, Wis.*

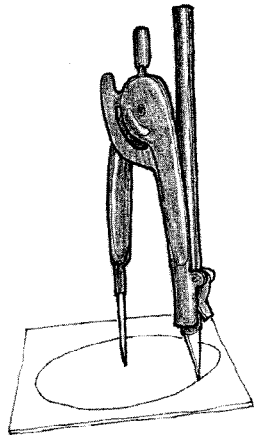

Wrench tenon cutters

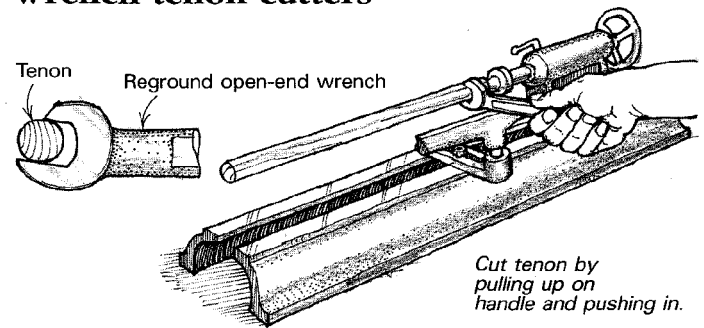

Here's a quick production method for turning tenons: You can make a precision tenon cutter by modifying a high-quality open-end wrench of the same size as the desired tenon. First, carefully grind and sharpen the top jaw at an angle, as shown in the sketch, to provide a cutting edge. Add a handle to the tool if you like. Next, turn the stock to within $\frac{1}{8}$ in. of the desired tenon diameter. Then, with the lower lip of the tenon cutter riding under the spindle, pull up on the handle and push in. The cutting action will stop when the tenon is sized—much like a go/no-go gauge. If the tool cuts tenons that are too small, file a bit off the lower lip.

—*Cecil Gurganus, Todd, N.C.*

Methods of Work buys readers' tips, jigs and tricks. Send details, sketches (we'll redraw them) and photos to Methods, Fine Woodworking, Box 355, Newtown, Conn. 06470. We'll return only those contributions that include an SASE.

Two panel-raising fixtures

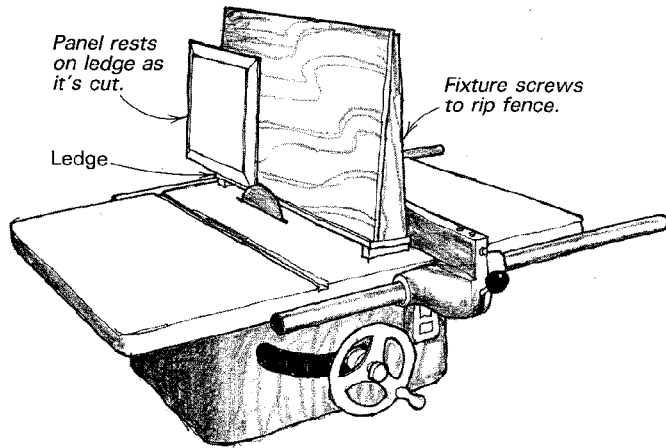

I made this fixture to expedite making dozens of 1/2-in.-thick, red oak panels 1 ft. wide by 5 ft. tall.

The height of the sawblade and the slope of the fixture produces panels beveled at 7 1/2°, with the shoulder of the field cut simultaneously. If you push the panels through carefully and use a high-quality carbide blade, you'll produce panels virtually free of machine marks, requiring minimal sanding.

—Warren W. Bender Jr., Medford, N.Y.

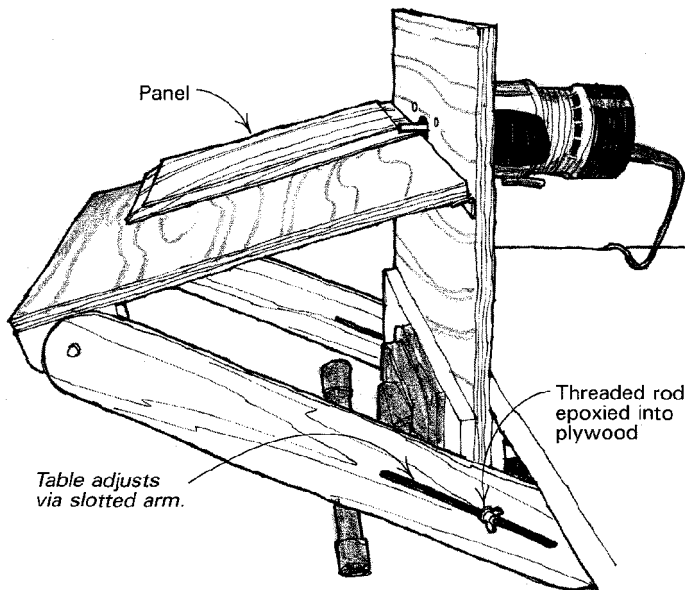

This router fixture is great for quickly and safely beveling panels. It's made from 3/4-in. plywood and some scraps. Its table is hinged and adjusts via a slotted support arm to vary the bevel angle.

I use a 1/2-in.-dia. carbide bit and make three passes. The first two passes remove the bulk of the stock. The final pass removes only about 1/32 in. of material and leaves a clean face without ripples.

—Gerald Robertson, Angus, Ont.

Bar-clamp gluing rack

I've noticed that many professional shops have clamp racks that are dedicated to edge gluing. These racks hold the bar clamps in position, allow the woodworker to inspect the underside of the boards for fit and free up the workbench for other operations.

Since dedicated racks may not be practical for a small shop, here's a simple clamp-holder block that converts a sawhorse into a clamp rack. The fixture is simply a short block of wood with

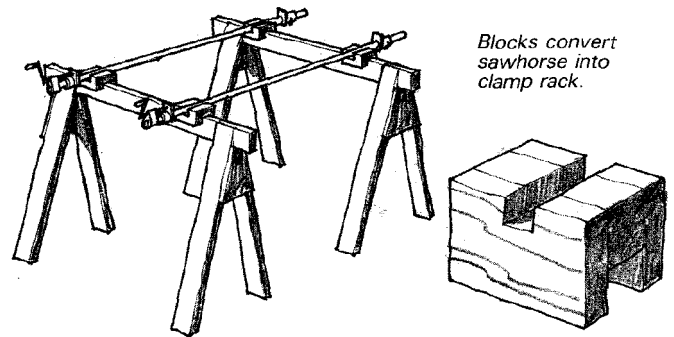

a channel ripped in the bottom to ride the horse, and a slot crosscut in the top to fit the bar clamp. If the top of your horse is a 2x4, you may wish to construct the block by gluing up a sandwich, as shown in the sketch. Make as many pairs of blocks as you'll need. The blocks stabilize the bar clamps and provide full flexibility of clamp spacing.

—George A. Burman, Fort Bragg, Calif.

Quick tip: For adjustable leveling feet on heavy pieces of woodworking machinery, try refrigerator and freezer leveling feet. Appliance repair shops will frequently give these away or charge just a few cents.

—Harold J. King, Salem, Va.

Doweling guide

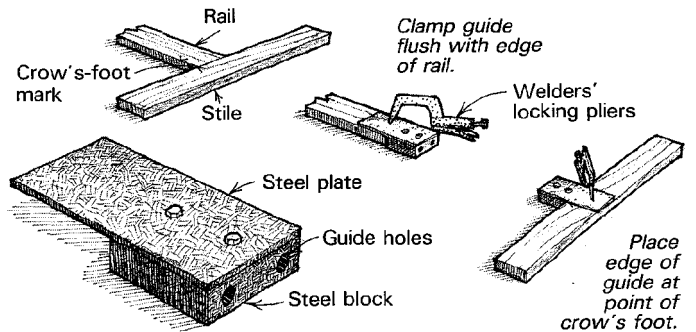

Before we discovered this simple steel guide for doweling the joints on cabinet fronts, we tried several other approaches, including an expensive two-spindle horizontal drill.

Make the guide out of a 1 3/4-in. square, 3/4-in.-thick steel block. Drill two 1/16-in. holes (for 1/16-in. dowels) through the block. The holes should be spaced 1/8 in. in from each side of the block. The usability of the guide depends on the accuracy of these holes, so drill them precisely with a drill press. Complete the guide by bolting a 3 1/2-in. length of steel plate flush to at least one face.

After your rails and stiles are cut, mark the joints as shown in the sketch. Clamp the guide to the side of the stile with one edge of the guide flush with the mark and drill the two holes. Then, use the guide to bore the two holes in the end of the rail.

Whatever marking system you decide to use, just make sure you're consistent throughout. The drawing shows the crow's foot mark. The advantage of this mark is that if you place the guide so you can't see the crow's foot, then you're boring on the wrong side of the mark.

—Tim Hanson, Indianapolis, Ind.

Iron-down veneer

To apply veneer edging strips, coat the strip and the edge with white (not yellow) glue. My glue applicator is a plastic-laminate roller covered with masking tape, which I remove after the glue is spread. Allow the glue to dry. Then iron down the veneer us-

ing a household iron on the highest setting. Move the iron back and forth over a 12-in. to 14-in. area to heat it, then press with the roller to fix the bond. This method produces a strong glue joint with no mess, no clamps, and no fumes from contact cement.

—William J. Bosco, Garberville, Calif.

Mitering trim on the bandsaw

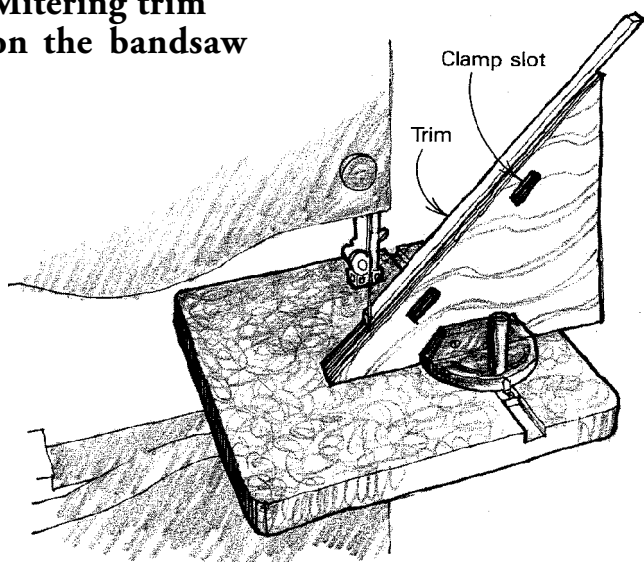

When I needed to miter a few dozen 1/8-in.-thick cock beads, I first tried a chop box, but found it produced severe chipping behind the cut. So I built the fixture shown here to cut accurate miters on the bandsaw and avoid chipping. The fixture is simply a couple of 45° plywood triangles glued together and mounted upright to the saw's miter gauge. I routed two slots, as shown, to accommodate spring clamps that hold the trim to the fixture. Before use, push the fixture into the blade to leave a sawkerf halfway through. This sawkerf will serve as an index line for exact placement of the trim to be cut.

To use the fixture, first cut a trial piece to make sure the miter angle is an accurate 45°. If not, adjust the angle by tilting the saw table slightly. Next, cut each strip of trim about 1/2 in. longer than needed, then snip the mitered corners off in the fixture.

—Dave Evenson, Cumberland, Wisc.

Quick tip: A piece of foam carpet underlay on your bench will provide a slip-proof cushion for beltsanding boards and panels. The foam is much quicker and easier to use than a vise and benchdogs.

—Keith Manser, Warsaw, Ont.

Universal bending form

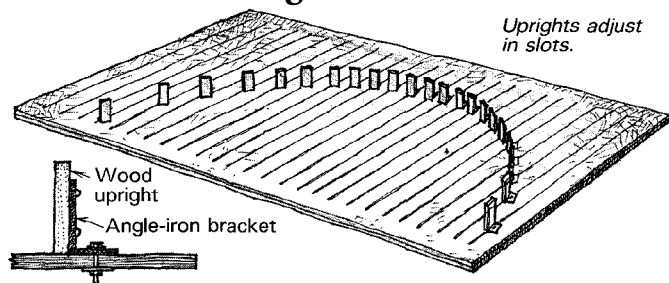

I was recently commissioned to build an arch for a client who had knocked an opening in the wall between his kitchen and dining room. Not wanting to be stuck with a big, expensive form when the job was done, I made an adjustable and reusable form for bending the arch.

The form was made from 3/4-in. plywood, and was through-

slotted every 4 in. with a 1/4-in. bit in my plunge router. I stopped the slots about 2 in. from each edge. I then strengthened the plywood (made flimsy from the slots) with a 1x2 wooden frame and three crossmembers attached to the bottom. I had a local metal shop make 25 angle-iron brackets, to which I attached pine blocks whose edges had been rounded over to minimize marking the work. A 1/4-in. bolt with a small washer on top and a large washer underneath holds the bracket to the formboard after it has been set at the proper location. If a bracket is needed where there's no slot (as often happens near the ends of the curves), I just drill a 1/4-in. hole where the bracket's needed.

—Jason Tessler, D.N. Maalay Hagaziz, Israel

Quick tip: Used aluminum offset-printing plates, which most newspapers either give away or sell cheap, make good template material.

—Harry McCully, Allegany, N.Y.

Grinding bowl-turning gouges

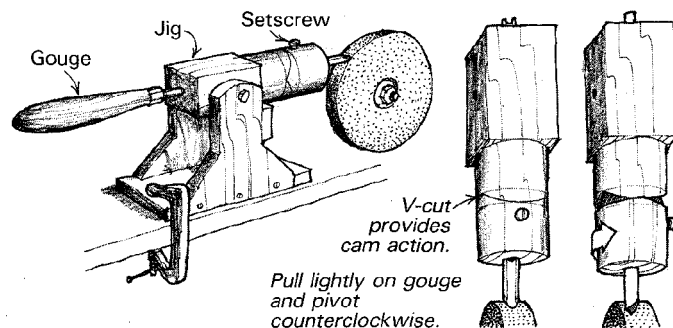

Borrowing some ideas from fellow turners, I devised this jig for grinding the fingernail shape on bowl or spindle gouges. I find this too tricky to do freehand; you not only have to rotate the gouge while grinding it, but have to move it forward and back.

Start with a 2-in.-square hardwood block, 6 in. long, and turn a 2-in.-dia. cylinder in the middle of the block, leaving the back 2 in. and the front 1/2 in. of the block square. The rear square is fastened to the base, the front steadies the turning on the bandsaw and will be cut off. Bore a hole along the center of the block equal to the diameter of the gouge to be ground.

Make a V-cut in the cylinder; this provides a forward cam action during grinding to produce the fingernail shape. The depth of the V-cut should be half the diameter of the gouge. To make the cut accurately, scribe two circles around the cylinder half the diameter of the gouge apart. Draw a centerline down the cylinder's length, bisecting the two circles. In plan view, start the cut where the circle nearest you meets the cylinder's surface and end the cut where the farthest circle intersects the centerline. Without pivoting the cylinder, repeat the procedure on the next cut.

The back of the jig is bolted to the base so it can pivot away from the grinding wheel. Drill a small hole for a setscrew through the side of the front cylinder to hold the gouge in place as it's ground.

To use the jig, hold the two cylinders together and push the gouge, flute side up, through both parts and tighten down the setscrew. Adjust the jig so the gouge hits the wheel to produce a 30° bevel angle and clamp the jig down. Lower the gouge into the wheel and rotate it counterclockwise while pulling back on it enough so the two parts of the cylinder stay together.

—Clif Sessions, Bartow, Fla.

Methods of Work buys readers' tips, jigs and tricks. Send details, sketches (we'll redraw them) and photos to Methods, Fine Woodworking, Box 355, Newtown, Conn. 06470. We'll return only those contributions that include an SASE.

Two wall-thickness calipers

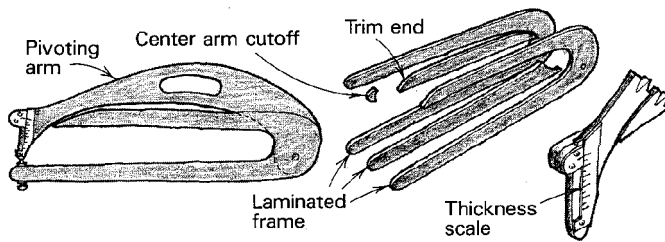

I believe this thickness caliper is simpler and less prone to error than Gilbert Warmbrodt's technique ("Methods of Work," *FWW* #64), which involves using both a dial caliper and a spring caliper. I made mine from plans carried in a 1950s British woodworking magazine.

The calipers consist of a 3-piece laminated frame and a pivoting arm. Make it by screwing together three pieces of $\frac{3}{16}$ -in. Baltic birch plywood (sold in model and hobby shops). Next, cut the three pieces into the U-shaped caliper frame. Cut the pivoting arm from Baltic birch to the shape shown in the sketch. Disassemble the three frame pieces and cut apart the middle piece as shown to allow clearance for the pivoting arm at the back and front of the caliper. Save the cutoff from the center piece; the pointer plate is screwed to it and then attached to the left frame piece. Trim the front of the right frame piece so you can read the measured thickness.

Glue the three frame pieces together, bore a hole through them and bolt the pivoting arm in place with a wing nut on its end to adjust the pressure on the arm. For the scale, mark off a strip of $\frac{1}{16}$ -in.-thick aluminum or brass in $\frac{1}{32}$ -in. increments. Screw or glue the plate to the pivoting arm as shown. Sharpen the end of a small bolt and center it on the bottom of the frame so the tip of the pivoting arm meets it. With the caliper closed, mark a fine line from the thickness scale to the pointer plate to indicate zero.

—John Bickel, Ossining, N.Y.

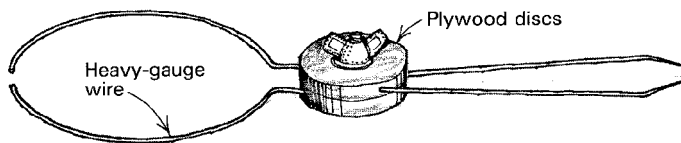

These shopmade calipers are made from two 3-in.-dia. plywood discs, a bolt and wing nut and four pieces of heavy, stiff wire. Accuracy depends on two conditions. First, the distance from the pivot to both ends must be exactly the same. Second, when the caliper jaws are closed, the two chisel faces at the other end must also touch. To use, bring the curved ends together on the workpiece and measure the thickness as the distance between the two chisel faces on the other end.

—Ralph S. Mason, Portland, Ore.

Quick tip: For color-matching in small spots, try Maybelline eyebrow pencils.

—Jim Buell, West Covina, Calif.

Shopmade chisel-nose plane

The Stanley #97 chisel-nose plane, originally made for trimming and fitting piano parts, is also useful for trimming off plugs and planing into corners. Its iron is mounted on the front of the plane at a very low 16° .

Unfortunately, the Stanley #97 is hard to find and collectors often shell out \$300 for them. The alternative is to make your own from a plane iron, lever cap, T-nut, $\frac{1}{4}$ -in.-dia. round-head machine screw and a piece of dense 2-in.-thick hardwood, 3 in. wide by 10 in. long. Don't use a regular bench-plane iron, as it's not heavy enough; I used an inlaid tapered iron from an

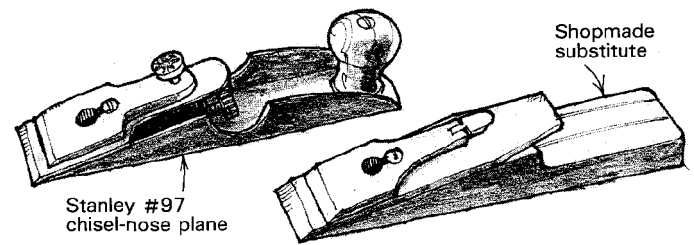

old wooden jointer plane. These heavy old irons are fairly common at flea markets and antique tool sales.

Shape the wooden blank as shown and set the iron and cap on the blank, align the screw holes in each and mark the location of the hole. Bore a through hole on the mark perpendicular to the blank's angled face. Enlarge the hole on the plane's sole and install a T-nut. Add a knob if you wish.

—Philip Whitby, Englewood, Colo.

Quick tip: It is important to flatten plane and scraper blades, but they are hard to hold while hand-lapping. I solved the problem by using suction cups as handles. A little soapy water ensures good suction.

—B.A. Cartwright, Cedarburg, Wisc.

Canned lubricant

Lightly oiling a handsaw's blade or a plane's sole makes the tool easier to use by reducing friction. Just tightly roll up a 2-in.-wide band of upholsterers' hessian webbing, tuck it into a tuna-fish can and soak with thin machine oil. Then wipe the tool over it, or it over the tool. Resoak the block if it dries out.

—H.G. Durbin, Porthcawl, Eng.

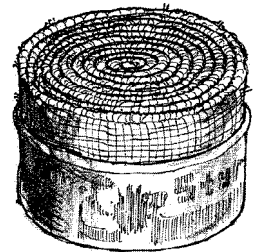

Disposable doweling jig

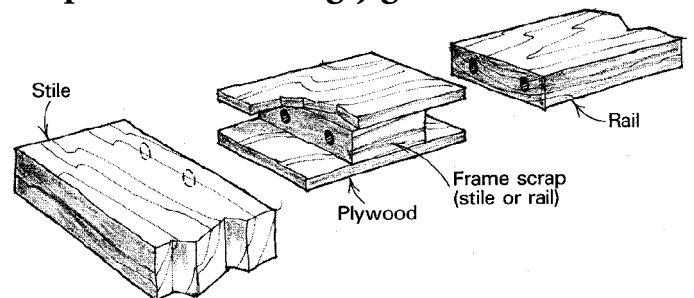

When joining face frames, make this doweling jig from $1\frac{1}{2}$ -in.-long scraps from the frame's rail or stile and a piece of plywood. Bore the two guide holes in the block on a drill press, then glue the block between two pieces of $\frac{1}{4}$ -in. plywood that extend 1 in. from each end of the block. Mark one face and one edge of the jig as reference surfaces to ensure consistency when drilling dowel holes.

—Ronald F. Seto, San Rafael, Calif.

Quick tip: Rip an old undershirt off just below the armholes. Double up the lower part and wear it as a headband while you work. There is plenty of absorbency, and I've found that if this headband ever gets saturated, it's probably time to quit work anyway.

—Lawton E. Reid, Kansas City, Mo.

Belt tightener

Often a power tool belt will slip just when it's needed most. You can keep the old stretched belt tight (until it can be replaced) by installing a wooden idler pulley similar to the one

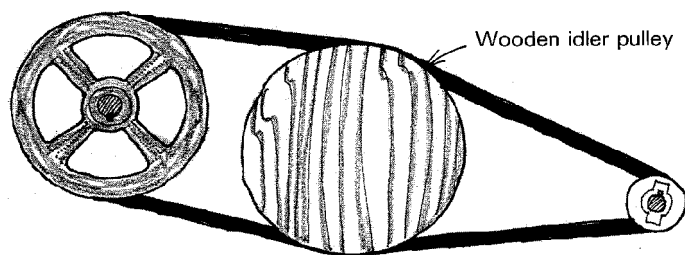

shown in the drawing above. Turn the wooden disc on a lathe so its diameter is larger than either pulley on your equipment. Use a skew chisel to cut a V-groove in the edge to fit the profile of the belt. Pull the belt apart slightly and insert the pulley. In operation, the free-running idler pulley will move up and down seeking its own invisible center.

—Donald F. Kinnaman, Phoenix, Ariz.

Quick tip: Instead of using sawdust and glue as a wood filler, use sawdust and sanding sealer. It dries quickly and will never leave a white spot, as the glue mixture will if not sanded off completely.

—Myron Mykiwka, Guatemala, Guat.

Plywood keeper

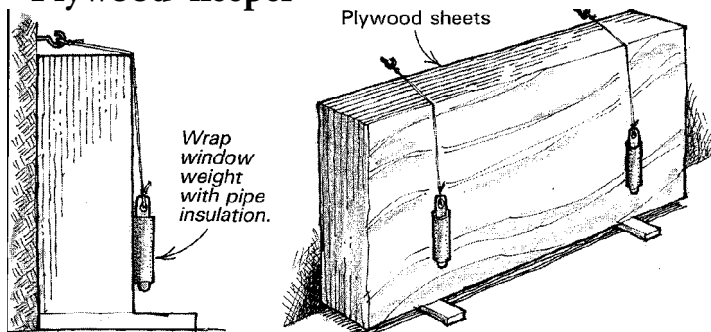

I've used this method on stacks of plywood up to 30 sheets thick. Sink two eyescrews into the wall about 51 in. off the floor. Tie two sash weights to a piece of string and suspend each weight from an eyescrew. Cover the weights with foam pipe insulation to keep them from marring the plywood.

—John R. Thiesen, Cheektowaga, N. Y.

Woodcarver's vise

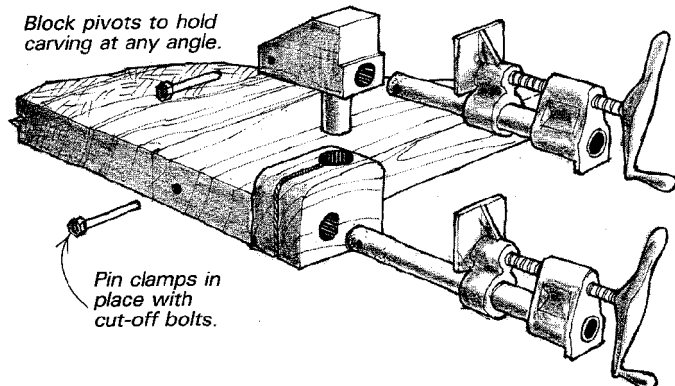

The pipe-clamp vise shown above makes my woodcarver's clamping system ("Methods of Work," FWW #55) even more versatile. Work can be clamped in virtually any position in the top vise, which pivots around 360°. The bottom clamp locks the top vise at the desired angle.

—Wallace C. Auger, Fairfield, Conn.

Safely removing small cutoffs

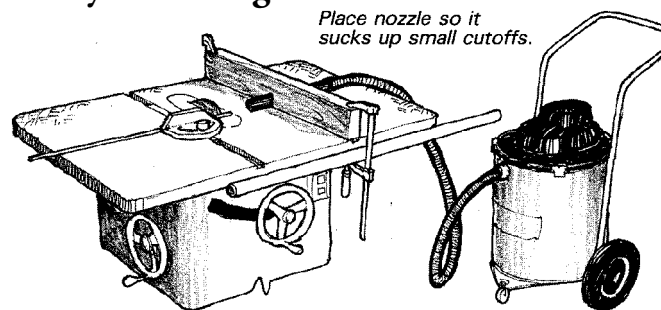

A good way to remove small cutoffs (such as chunks sliced off a dowel) from your table saw or bandsaw is to suck them in with your shop vacuum. Fit the vacuum's nozzle through a 2x4 notched to fit its hose diameter. Clamp this setup on the table-top with the nozzle mounted as close to the cut-off point as possible. When you're done, the parts are neatly collected in the barrel.

—David Shaffer, Grand Rapids, Mich.

Quick tip: Old tire pieces clean sanding discs and belts. Interstates are full of them.

—Myrl G. Brooks, Cleveland, Tenn.

Lathe layout tool

More convenient than a marking stick and pencil, this scribing gauge speeds spindle turning by scoring several layout lines at once. I use drywall screws as marking pins. Made from hardened steel, their tips stay sharp for making clean, thin lines. Space the screws to correspond to key measuring points on the workpiece. The gauge shown here might be used to mark divisions on a short honey dipper, but there is no reason you can't make it the full length of long work.

—Galen Miller, Vestal, N. Y.

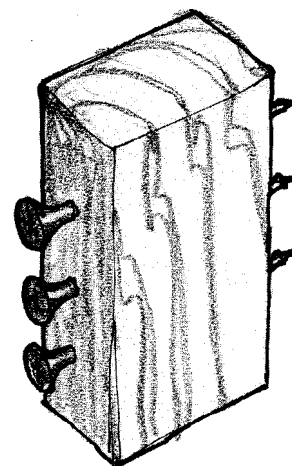

Installing small brass knobs

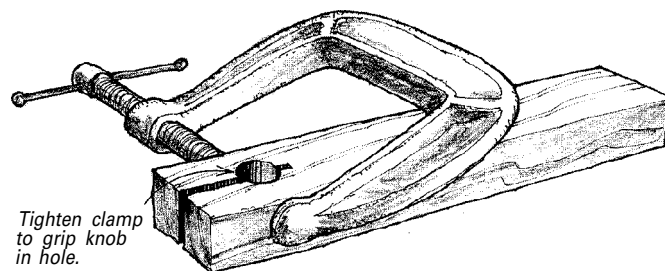

Small brass knobs with threaded shanks can be difficult to install without marring their finish, especially in very hard woods. I solved the problem with this grip made from scrap wood. Use a small C-clamp to squeeze the knob in the hole, but take care that the clamp doesn't drag on the wood and scratch it. The wood scrap acts as a non-marring handle, allowing easy installation of the knob.

—Mac Campbell, Harvey Station, N.B.

Methods of Work buys readers' tips, jigs and tricks. Send details, sketches (we'll redraw them) and photos to Methods, Fine Woodworking, Box 355, Newtown, Conn. 06470. We'll return only those contributions that include an SASE.

Cutting small parts on the tablesaw

I made this fixture to cut parts for small models and miniature furniture. It works so accurately and safely that I cut even conventional-size parts with it instead of using the miter gauge.

The fixture is made from a piece of plywood that is 8 in. to 14 in. longer than the table, depending on the length of cuts you plan to make. Screw hardwood runners underneath the plywood to slide in the miter-gauge slots, and screw stop blocks at both ends of the underside to prevent accidentally cutting the fixture in two. With the fixture in place, raise the blade through it to cut the blade slot.

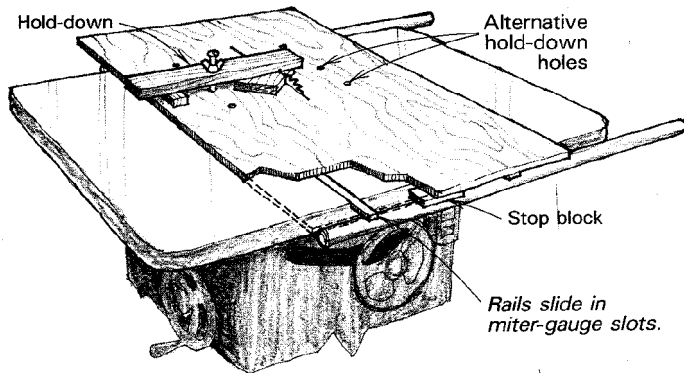

Drill several hold-down anchor holes through the plywood and install $\frac{3}{8}$ -in. T-nuts underneath. I have various anchor locations on my fixture to suit my individual operations. A small wood scrap will serve as a hold-down. Bore a hole through it for a $\frac{3}{8}$ -in. bolt, and thread a wing nut over the bolt before putting it through the wood block. Place the workpiece under the hold-down near the blade and place a block the same thickness as the workpiece at the other end of the hold-down—just tighten down on the wing nut to hold the workpiece in place.

I've found the hold-down applies enough force to lock the workpiece in place in just about any cutting operation, and my hands never come near the moving blade.

—Don H. Anderson, Sequim, Wash.

Quick tip: Woodturners: For a tight-spot smoothing tool, untwist a length of twine, then retwist it with steel-wool fibers trapped in the weave. —Thomas S. North, Bloomfield, Conn.

Built-in table extension

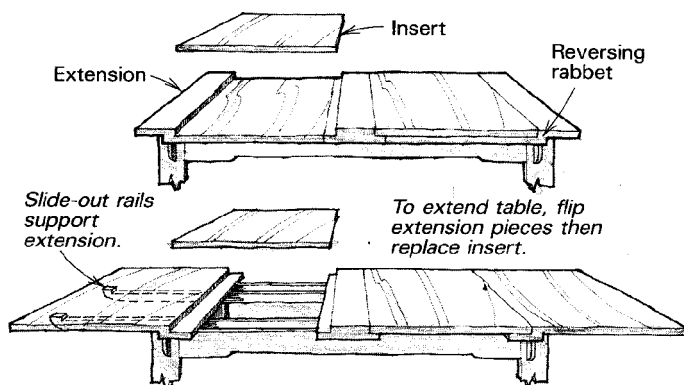

Here's a table that can be extended without the nuisance of separately stored leaves. The table's top consists of a fastened central piece, two inserts and two extensions. To extend the table, lift up the inserts, then flip the extensions so the rabbets under their ends are facing up. The two inserts fit into the rabbets, and two rails slide out from the table's ends to support the extensions.

—Brian Timius, North Hollywood, Calif.

Double-duty edge-gluing clamps

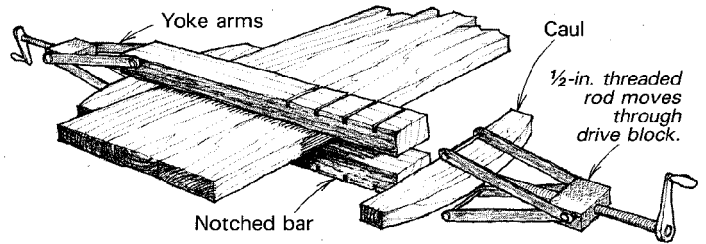

This shop-built edge-gluing clamp performs double duty. It not only is a terrific bar clamp, but it also aligns the various workpieces being glued, thus eliminating the need for a separate alignment "sandwich" made with scrap and C-clamps.

The clamps consist of two yokes and two notched wooden bars. Each yoke assembly has a pair of trapeze-like arms made from 8-in.-long pieces of strap iron that pivot on the sides of a block made from $\frac{3}{4}$ -in.-thick mild steel. Drill and tap a hole through the block to accept a $\frac{1}{2}$ -in. threaded drive rod. Then, drill and tap $\frac{1}{4}$ -in. holes in the sides of the block to bolt the arms in place.

Next, screw a length of $\frac{1}{2}$ -in. threaded rod through the block and attach a knob or crank to its outboard end. To distribute clamping pressure, make a wooden caul with a shallow $\frac{1}{2}$ -in. hole bored in its edge to locate the end of the rod. Plane a shallow concave curve in the caul edge that contacts the work to ensure even distribution of clamping pressure.

Cut the clamp's notched wooden bars from $1\frac{1}{4}$ -in.-thick sticks of hardwood. The bars should be as wide as the space in the yoke arms. To make sure the notches in the bars are perfectly aligned, cut both bars at the same time with a $\frac{1}{4}$ -in. dado blade.

—William Swartz, Modesto, Calif.

Quick tip: When doweling with dowel points, I always drill the first holes in the endgrain side of the joint, because drill bits in endgrain are much more likely to drift a little off the intended center.

—John W. Wood, Tyler, Tex.

Cord-loop storage

Here's a looped-cord storage system that has proved to be a great way to put empty wall space to use. It can be made to work with just about any kind of shop item. I use it to hang tools, bags of hardware or tin cans holding small wood parts. The last time I counted, I had about 50 different things suspended on my shop walls, and they are all plainly visible and easy to get at. I much prefer this to having everything cluttered in corners, hidden in drawers or under my bench. And, an empty cord hanging on its nail tells me that something isn't where it should be.

—Don H. Anderson, Sequim, Wash.

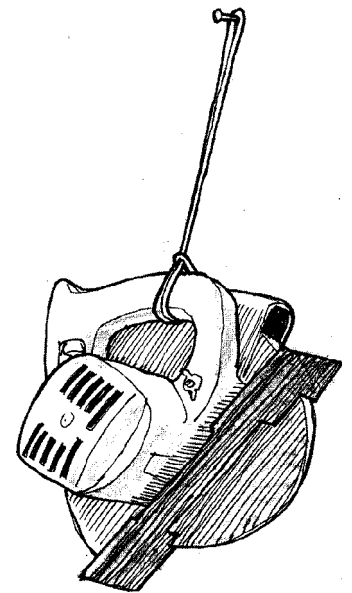

Driving with old engine valves

I've found that an old car valve works well as a live center for turning the base on a bowl that has its top edge left natural from the log. The valve stem is small enough in diameter to fit in a Jacobs chuck, and it's long enough to allow fairly deep

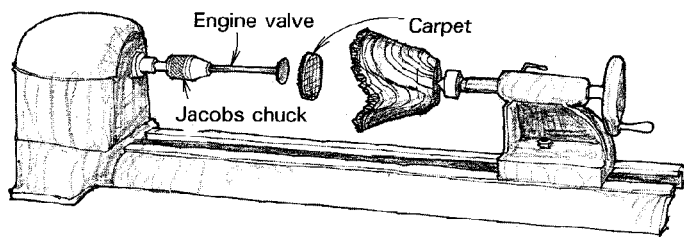

bowls to be turned. The valves are usually free, because service stations that rebuild engines normally throw them out.

First, I fasten the valve in the chuck. Then with a small circle of indoor-outdoor carpeting inside the bowl for padding, I bring the ball-bearing tailstock up to the center of the bowl's bottom, which I've marked with a centerfinder. You need quite a bit of pressure for this technique to work properly, so leave plenty of wood on the bowl's bottom when you are roughing it out; you don't want the tailstock center to punch through the bottom. Things may get out of balance, so wear face protection and keep your lathe at low speed. Be sure to leave enough wood around the tailstock center for safety; this nub will be easy enough to clean up by hand after the bowl is removed from the lathe.

—Robyn Horn, Little Rock, Ark.

Quick tip: An engine valve makes an excellent spot sander. Chuck the stem in the drill press and attach garnet discs with rubber cement.

—Donald F. Kinnaman, Phoenix, Ariz.

Routing fingernail edges

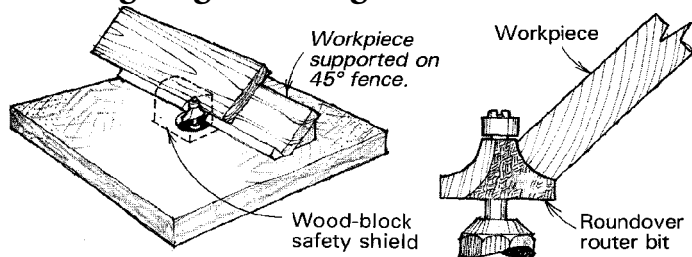

Your roundover router bits can do double duty cutting fingernail-shaped edges if you simply change the angle at which the work moves into the bit. I use the bits in a router table with an auxiliary fence that presents the stock to the bit at a 45° angle as illustrated. A 1/2-in. bit will mold the shape on 5/8-in.-thick stock, and a 3/4-in. bit will handle 1-in.-thick stock. Notice that the lip on the fence acts as a track for the work and must have a gap in it so the bit can contact the work. For occasional use, this method beats buying the expensive specialty bit.

—Jeffrey P. Gyving, Point Arena, Calif.



Mason-jar glue pot

A mason jar makes a good glue pot. Drill a hole through the lid insert to fit the handle of a disposable foam paintbrush. To let the brush hang in the pot, put the insert ring on top of the twist-on cap, as shown in the sketch. You can adjust the height of the brush with a rubber band around the brush handle. The twist-on ring gives a nice scraping edge for wiping excess glue off the brush.

—David L. Pitz Redding, Calif.

Turning from the left

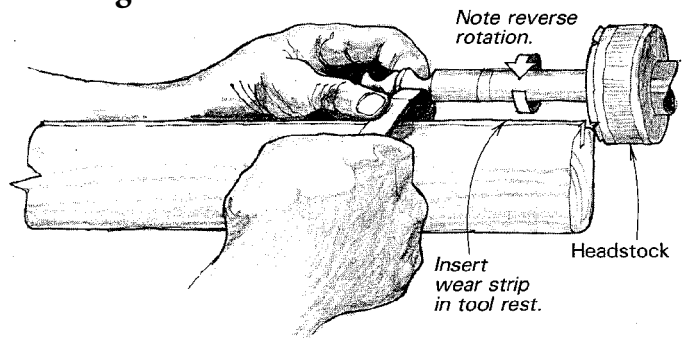

This two-handed lathe technique works well for production turning small pieces. Note that the headstock is to the turner's right. The turner sits sideways, facing the headstock, his left arm over the tool rest with his elbow on the lathe bed. He holds the tool handle in his right hand, and with the left, guides the tool and steadies the spindle to prevent chatter.

A right-handed turner would have to turn his lathe 180° (headstock to the right) and reverse motor direction to use this technique. A left-handed turner would do this backward, with the headstock in its normal position and his right elbow resting on the lathe bed.

The full-length tool rest is made by insetting a wear strip in a long piece of wood.

—Johannes Volmer, Erzgebirge, G.D.R.

Makeshift plunge routing

You can adapt a standard router with a screw-lowering mechanism to allow it to make plunge cuts. Fasten a hose clamp around the waist of the motor housing to stop the plunge cut at the desired depth. Loosen the router's tightening cam halfway and spray inside the base with Teflon lubricant.

—James Gentry, Madison, Wis.

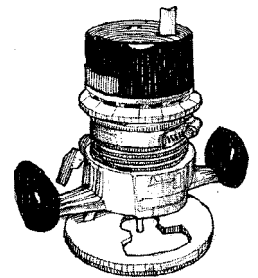

Venturi-box dust catcher

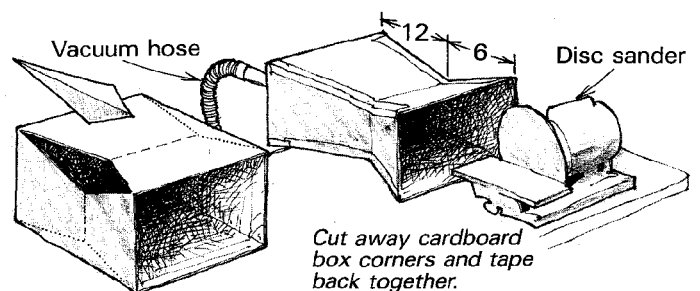

My venturi box is an improvement over the standard box-like hoods that are normally used with shop vacuums in dust collection hookups. I use it to catch dust thrown by my bench-mounted disc sander. Try it at various locations behind the sander wheel until you find the most efficient spot. Air drawn through the box speeds up at the constriction, creating a pressure drop in the rear half of the box, effectively increasing the pull from the shop vacuum. Use any heavy, smooth cardboard box, cut away portions of each corner to produce the double taper shown and reassemble the box with duct tape.

—Gordon Baxter, Beaumont, Tex.

Methods of Work buys readers' tips, jigs and tricks. Send details, sketches (we'll redraw them) and photos to *Methods*, Fine Woodworking, Box 355, Newtown, Conn. 06470. We'll return only those contributions that include an SASE.

Two drill-press sharpening systems

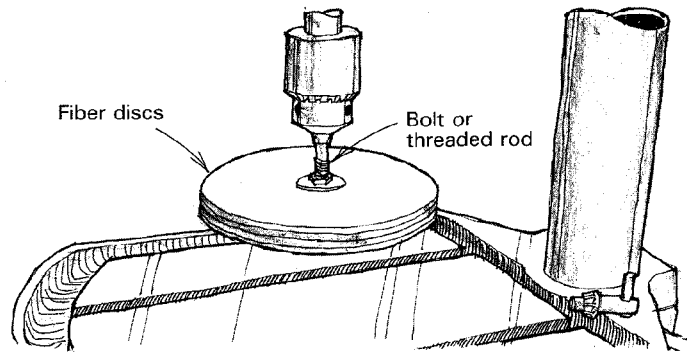

This drill-press stropping wheel cost me about \$2 to make and is handy to use because it spins horizontally and allows me to take advantage of the machine's low speed setting. To make the wheel, cut up four 6-in.-dia. circles of 1/4-in.-thick cardboard or fiberboard. Stack the discs, drill a hole through their center and use a 1/2-in.-dia. bolt or threaded rod as an arbor, with washers on both faces of the wheel. Mount the wheel in the drill press, true the rim of the wheel and remove any projecting fuzz with coarse sandpaper. With a pocket knife, score a spiral groove on the wheel's face from a point near the arbor to the edge to catch honing compound. With the wheel spinning, apply rouge or tripoli to its face and edge.

To sharpen a chisel, I buff its flat side first on the wheel's face, with the wheel's rotation running away from the cutting edge. I hold the chisel at an angle to the wheel, and for greater control, work near the center of the wheel where its speed is slowest. I sharpen the edge of the chisel on the edge of the wheel, once again, with the wheel running away from the cutting edge. Two or three passes on the chisel's edge leaves it beautifully polished and razor sharp.

—Leslie H. Blair, Rocky River, Ohio

With my interests in furniture building, turning and, lately, chip carving, I always have many chisels to sharpen. This simple system helps me sharpen my tools quickly. The system consists of a 9-in.-dia. aluminum disc with an arbor made from a bolt or threaded rod and chucked in my drill press. I glue a circle of 200-grit wet-or-dry abrasive paper to the disc with Glop, an adhesive sold at many auto-parts stores. Rubber cement also works but breaks down sooner. I adjust the drill-press table so the disc spins about an inch or two above the water level in a plastic wash basin that contains an inch of water.

To sharpen a chisel, I set the drill at 300 RPM and wet the wheel's face with a squirt from a large bulb-shape syringe and then lay the bevel on the wheel's face. I sharpen the chisel for a bit and then squirt on some more water. It works so well that even sharpening my lathe tools on it has become a pleasure.

—Robert D. Panza, Canoga Park, Calif.

Quick tip: I use an electric branding iron on my wood crafts. To make sure that the iron prints clearly, I clamp a steel square where I intend to brand my name and use the inside corner of the square to guide the iron. If the first brand does not come out clearly, I have a chance to darken the mark in exactly the same place.

Joseph Wilson, Wappingers Falls, N.Y.

Sawing veneers on the bandsaw

To produce veneer slices on the bandsaw, we use a sharp blade, a tall rip fence aligned with the line of cut for each particular blade and an easily adjusted fingerboard rack. The fingerboard rack, which is the real secret to producing quality veneer, exerts even, soft pressure against the stock. This allows the sawyer to concentrate completely on pushing the stock

smoothly and evenly through the blade. Because the cut is made in one continuous motion, you get a much cleaner piece of veneer. In fact, the veneer can usually be glued directly to the ground without having to thickness-sand errant sawmarks. Also, because the technique reduces the thick and thin spots in the slices, your veneer stock goes further.

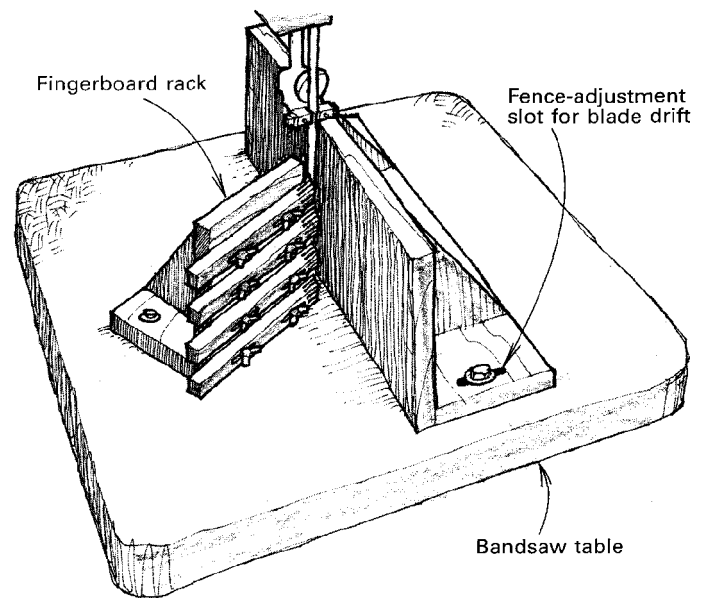

Make the rack platform from 3/4-in. plywood and the fingerboards from springy hardwood, such as ash or hickory. Cut sawkerfs in the end of the fingerboards both vertically and horizontally to soften the pressure, and fasten them to the platform with bolts through slotted holes. Leave the wingnuts on the back bolts loose so you can adjust and tighten the fingerboards easily with just the front wingnuts. With the fingerboards touching the veneer stock just in front of the blade, angle the rack about 60° from the line of cut and clamp the rack in place. If you intend to do much veneering, you may wish to drill and tap holes in your bandsaw table for mounting the fixture.

—Jeff Simon and Mark Darlington, Steamboat Springs, Colo.

Temporary micro-chuck

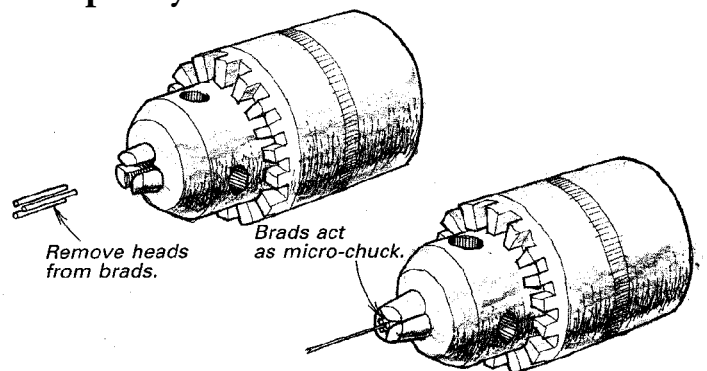

When I needed to drill several tiny holes but didn't have a micro-chuck for holding a tiny drill bit, I used three brads as a micro-collet. I first clipped the heads off the brads, then slipped them and the bit into the chuck as shown in the sketch.

—Paul Schulman, Belle Harbor, N.Y.

Foam sanding block

I don't know why, but we have a hard time keeping sanding blocks around our college shop. One evening, as time for class approached, I suddenly found myself out of them. In desperation,

I quickly bandsawed a number of blocks from 1½-in.-thick plastic-foam insulating board, figuring they would last just long enough to get through that class. To my surprise, the fragile foam blocks held up well and proved to have unanticipated advantages. They were not only lighter than wood blocks, but they also conformed to uneven surfaces better than the felt blocks I had been using. —Mark White, Kodiak, Alaska

Pipe-clamp bench vise

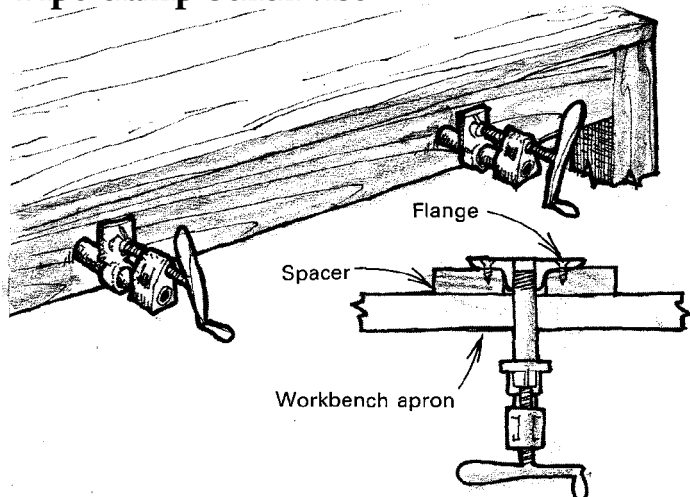

This simple but effective clamping system can be well-adapted to a workbench with a sturdy frame member that runs across the front. The system uses two pipe-clamp heads, two 8-in. pipe nipples and two pipe flanges. The pipe flanges are screwed to the back side of the frame, as shown above, with a plywood spacer between the flange and the frame. The spacer allows the pipe holes through the frame to be the same size as the pipe rather than the larger size that would be required to accommodate the flange. I locate the pipe holes so the clamp heads do not stand above the benchtop, but this decision is based solely on personal preference. —Don Rosati, Easton, Conn.

Quick tip: If your regular cabinet scraper won't fit in a tight spot, you can file off the back of an old knife and pull a satisfactory burr on it. —Jamey Hutchinson, Warwick, RI.

Making fluted panels revisited

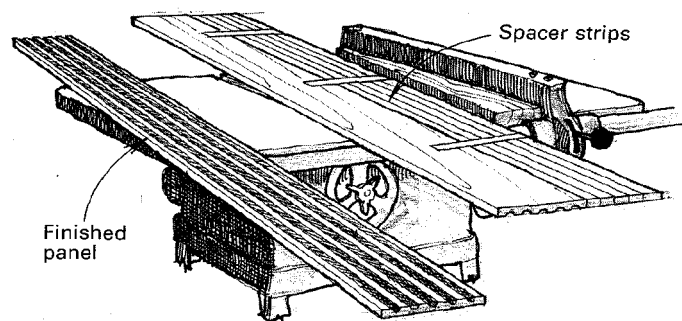

Here's an improvement to Wayne Kulesza's method for making fluted panels (*FWW* #67, p. 8). First, determine the proper fence angle to produce the flute width desired, then clamp an auxiliary fence to the saw. Tape several spacer strips to the side of the workpiece; the width of the spacer strips determines the distance between flutes. Push the workpiece and spacers through the saw to cut the first flute. If your blade is sharp and the flute not too deep, it should be possible to cut each flute in one pass. After you have sawn the first flute, slice off the outer-

most spacer by cutting the tape with a utility knife. Continue making passes and removing spacers until you have completed the panel. The spacer strips eliminate the time required in re-setting the fence for each pass through the blade.

If the blade binds and prevents you from cutting each flute in one pass, there are two alternatives: You can raise the blade in increments as you cut each flute, or you can make a series of shallow flutes across the width of the board, then replace the spacer strips, raise the blade and repeat the series until full depth is achieved. To ensure equal depth on all flutes, I would choose the second alternative. —Joe Videtic, Joliet, Ill.

Quick tip: You can balance bandsaw wheels with automobile wheel-balancing weights. They press on where needed and stay put. —Donald E. Wigfield, Moneta, Va.

Modifying drill bits for brass

Here's a tip well known in the metalworking field, but perhaps not common knowledge among woodworkers. When drilling soft metals such as brass, always grind or stone a small flat on the bit's cutting edge. This flat prevents the drill from chattering and results in much cleaner drilling.

—Thomas J. Tidd, Springfield, Pa.



Quick tip: Instead of stick-on felt bumpers for cabinet doors, I recommend you try bumpers cut or punched from vinyl-foam weatherstripping, which is sold in ¾-in.-wide rolls in local hardware stores. —Charles J. Cetti, Pensacola, Fla.

Auxiliary tablesaw switch

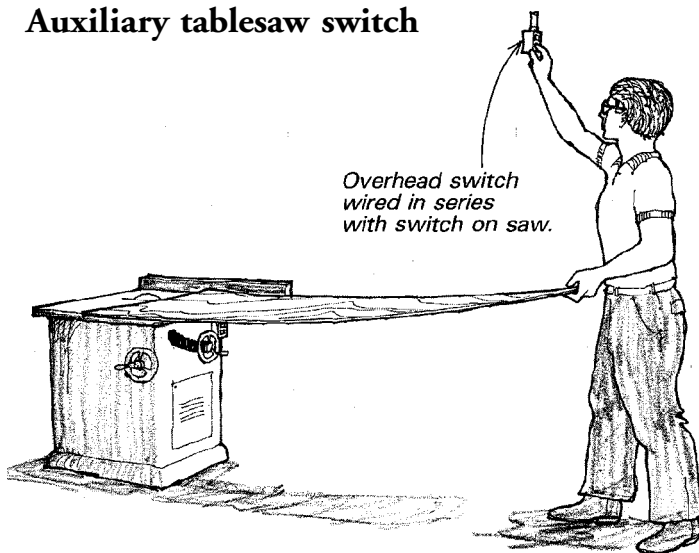

Here's how I solved the problem of operating the start/stop switch on my tablesaw when ripping large sheets of plywood. I installed a switch identical to the one on the saw at a convenient overhead location near the front of the saw. I wired this switch in series with the saw's switch so that both have to be "on" to let the saw run, but either switch will turn the saw off.

In use, I first make sure the overhead switch is off, and then I switch the saw on. I get the plywood into position and then reach up and flip on the auxiliary switch. For normal operations, I leave the overhead switch in the "on" position and use the saw's switch. —Charles W. Leffert, Springfield, N.J.

Methods of Work buys readers' tips, jigs and tricks. Send details, sketches (we'll redraw them) and photos to *Methods*, Fine Woodworking, Box 355, Newtown, Conn. 06470. We'll return only those contributions that include an SASE.

Drill-press cabinet

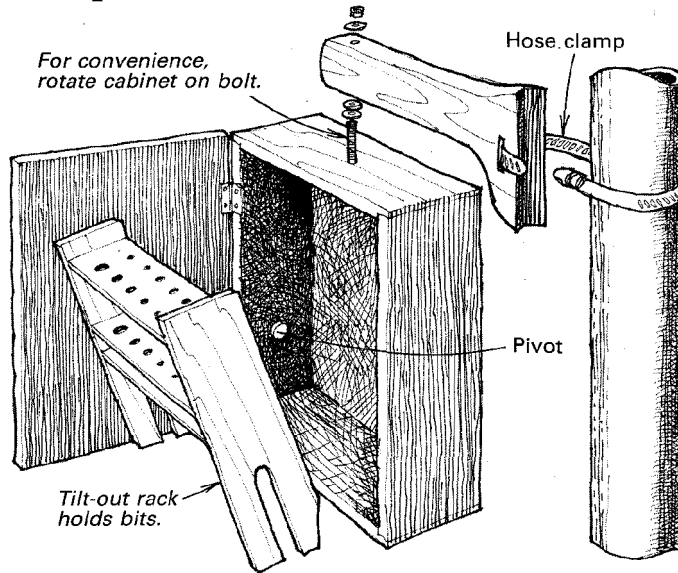

I use a standard stainless-steel hose clamp to attach a small cabinet to the post of my drill press. The cabinet, which holds drill bits and fixtures, hangs from a sturdy 1-in.-thick maple arm that has a shallow V-groove where it bears against the post. A slot cut in the arm receives the hose clamp's strap to hold it to the post. I round off the edge of the slot nearest the post to keep the strap from crimping too much when tightened. This mounting scheme is surprisingly rigid, and the cabinet can be removed quickly or repositioned with just a screwdriver.

The cabinet is a simple box about 15 in. high, 8 in. wide and 3½ in. deep, and it is attached to the arm with a ⅜-in. bolt. I put a couple of washers between the arm and the box so the box can be rotated to a convenient angle. The box is fitted with a standard drill-bit index on the bottom shelf to hold small bits and a shopmade rack above to hold larger bits. This rack flips forward so the bits can be removed easily without hitting the cabinet top. —James H. Smith, Champaign, Ill.

Quick tip: Old bowling pins make perfect hard-maple blanks for turning carvers' mallets and other projects. Damaged or worn-out pins are usually available at minimal cost from bowling alleys. —Stan Carlson, Grand Junction, Colo.

Cutting circles with a jigsaw

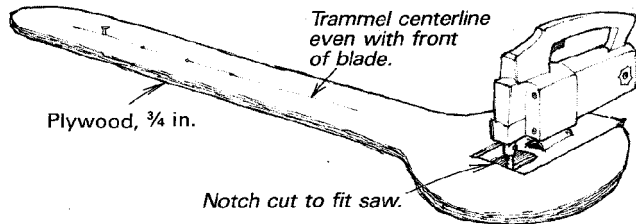

A jigsaw can quickly cut circles or large holes with this simple trammel made from scrap plywood. Cut the trammel leg to any convenient length, and make the head large enough so that you can saw a notch in it to seat the jigsaw. With the saw in place, draw a line perpendicular to the front edge of the blade and extend the line down the trammel's leg. Drill a pivot hole at the appropriate distance down the line, using a finish nail for a pivot pin. If you are going to save the circle you are cutting out, the kerf left by the saw must be outside the circle's circumference. The length from the center of the pivot pin to the

side of the blade closest to the pin equals the circle's radius. If you are cutting a hole (the cutout will be scrap), the kerf must be inside the hole's circumference. In both cases, apply pressure downward and outward while cutting.

—William S. White, Longwood, Fla.

Blast gates

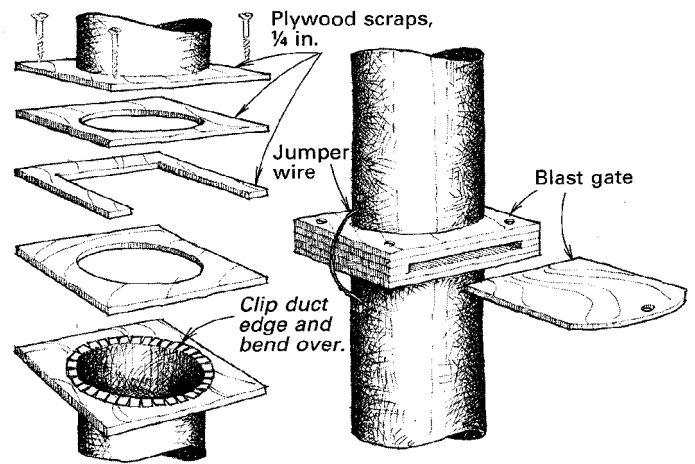

After reading about dust collection systems, I decided to install a system in my shop based on Grizzly's four-bag portable unit. First I fastened a 6-in. main line across the ceiling of my shop with 4-in. branch lines, fitted with blast gates, running down to each of my machines.

I built these blast gates by laminating pieces of ¼-in. plywood scraps as shown in the sketch. To attach the blast gates, I make cuts ¾ in. long, about every ½ in. around the perimeter of the duct, and then bend the tabs over. I slide a piece of plywood up to the bend on each length of duct, then screw through these pieces and the pieces of plywood between them. Although the gates work very well, they break the electrical continuity of the pipes, which can result in a sawdust-igniting buildup of static electricity. I solve this problem by installing a jumper wire from gate to gate. —Mike Cole, Coeur d'Alene, Idaho

Insulating pipe clamps

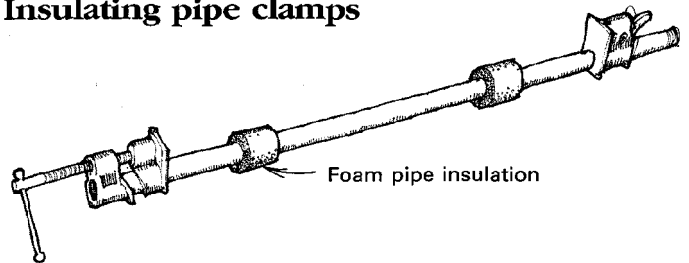

To prevent glue stains and dents while using your pipe clamps, cut two or more 2-in. sections from a length of foam pipe insulation and install the sections on the pipe as shown in the sketch. Foam pipe insulation is commonly available in several sizes at plumbing and building centers.

—Alan C. Sandler, Garnerville, N.Y.

Quick tip: As an aid in cutting straight lines in veneer, I tape garnet paper to the back of my ruler, which makes it much less likely to slip. —Hugh Aldred, Chester, U.K.

Sharpening system

I've replaced the sharpening stone and strop in my shop with a two-wheel buffer and two abrasive compounds commonly used by knifemakers and gunsmiths. First I grind the tool's edge on a regular grinding wheel, then I buff the edge on a muslin buffing

wheel loaded with a greaseless buffing compound manufactured by Lea Manufacturing Co. (available from Badger Shooter's Supply, Box 397, Owen, Wis. 54460; 715-229-2101). Even its fine grade cuts fast enough to send a few sparks flying, so I quench the tool often to prevent heat buildup. Next, I polish the edge with white No. 555 Polish-O-Ray (available from Brownells Inc., Route 2, Box 1, Montezuma, Iowa 50171; 515-623-5401). Alternate polishing the top and bottom of the cutting edge. Only a light touch is required to finish the edge to perfection.

—Robert Mordini, Edmond, Okla.

Veneering end edges

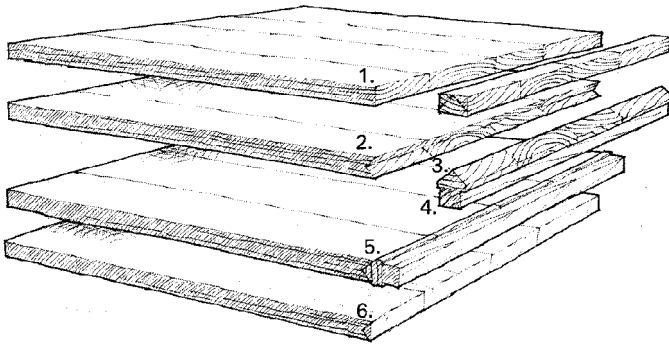

I use this process when building veneered period reproduction pieces that have a solid lumber core. This technique provides a better gluing surface than endgrain for the veneer without creating expansion problems as a breadboard end would. Step 1: After gluing up the core, slice a strip off each end that is $\frac{1}{4}$ in. wider than the core's thickness. Step 2: Cut a V-notch in the end of the panel. I do this on the shaper, but you can also do it on the tablesaw. Step 3: The strip will have two end-grain edges and two face-grain edges. Pick a face-grain edge and saw a peak on it as shown in the drawing. Step 4: Glue a scrap strip to the piece to act as a caul. Step 5: Glue the pointed end into the notch. Step 6: Saw off the caul, and using a handplane, fair down the glued-on piece so it is even with the core's edges.

—Harold Ineson, Westwood, Mass.

Quick tip: I recently had to plane some Brazilian rosewood to a thickness of $\frac{3}{64}$ in. To prevent the work from shattering in the planer, I double-taped the rosewood to a piece of $\frac{3}{4}$ -in. particleboard as a carrier.

—Max M. Kline, Saluda, N.C.

Wall hanger hardware

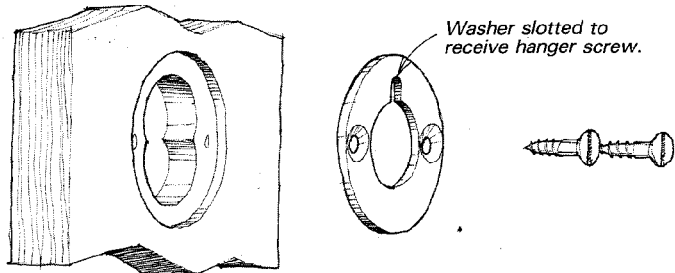

This modified $\frac{7}{8}$ -in.-OD steel washer lets you hang shelf brackets or wall cabinets flush against the wall. Drill a $\frac{5}{16}$ -in. hole near the inside edge of the washer and file the space between the hole and the washer opening to produce a slot. Now drill two countersunk holes in the washer for mounting screws. For lighter applications, you can skip the mounting screws and epoxy the washer in the recess. To install the hanger, drill a shallow $\frac{7}{8}$ -in.-dia. recess in the workpiece so the washer can be screwed flush to the surface. Drill two stopped, overlapping $\frac{3}{8}$ -

in.-dia. holes in the workpiece to make an oval-like cavity under the washer. The cavity allows for the downward movement of the cabinet or bracket over the head of the hanger screw, which is driven into a wall stud.

—Robert W. Terry, Palm Beach, Fla.

Production chamfering

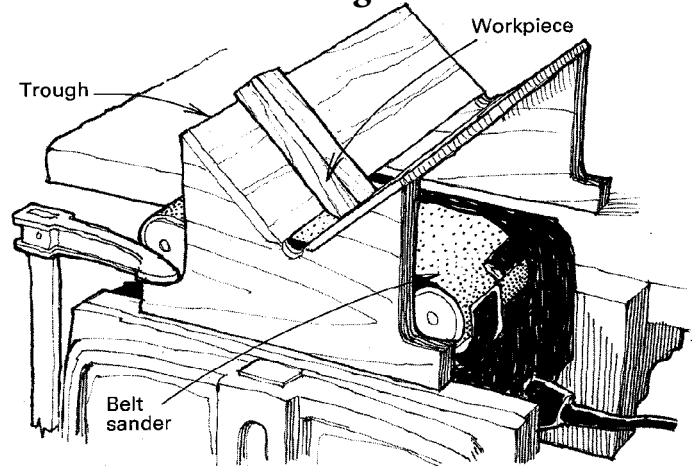

This setup helps you quickly sand an even chamfer on small parts. Build a trough with a slit in its bottom and position the trough straddling an inverted belt sander clamped in your workbench vise. The amount of chamfer is adjusted by raising or lowering the sander. Two words of caution: Don't obstruct the belt sander's ventilation opening when clamping the sander in the vise, and don't overtighten, lest you crack or distort the sander.

—Fred Palmer, Pensacola, Fla.

Quick tip: To prolong sandpaper's life, back the sheet with contactpaper.

—Donald F. Kinnaman, Phoenix, Ariz.

Coarse and fine sanding on the same disc

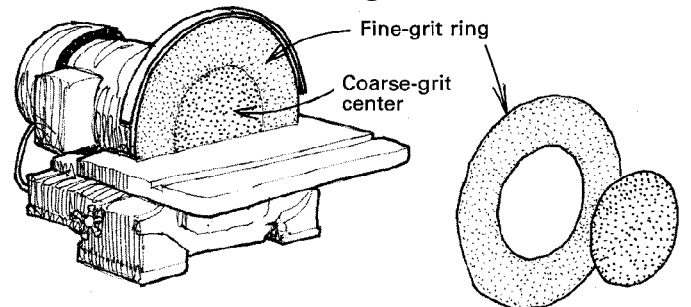

On some of the work I do on my 12-in. stationary disc sander, I often need to switch between 60-grit sandpaper for fast stock removal and 120-grit for finish-sanding. Changing the paper is a chore, and sometimes the paper is ruined in the process. For efficiency, I decided to try this two-grit arrangement. Using a compass, I scribe and cut my adhesive-backed sanding discs as shown in the sketch. This gives me a number of coarse and fine rings and circles. I combine a coarse outer ring with a fine inner circle (or vice versa) to produce the dual-grit sanding capability. Depending on whether the fine grit is in the center or at the circumference, I find it necessary to change sander speeds to avoid burning the work, but this has not proved a drawback.

—Gaylord R. Livingston, Chazy, N.Y.

Securing large vacuum bags

Here's my trick for preventing large dust-collector bags from popping off their flanges. I cut a 4-in.-dia. hose clamp into two pieces that I then pop-rivet to the ends of an appropriate length

of discarded metal band-strapping. This gives me, in effect, a super-long hose clamp that can be tightened quickly around the joint where bag and machine meet. I use the quick-release-type hose clamp, which makes the device very convenient when removing and replacing the vacuum's bags.

—James Christo, Jamestown, N. Y.

Quick tip: Use an old pencil sharpener to chamfer the ends of dowel pins.

—Charles A. Bailey, Davenport, Iowa

Making finger joints

The finger joint is not only an effective corner joint, but it can also be used for sharp bends and curves. This method for making finger joints minimizes cumulative error. I stack up four identical

6½ in. blades on my tablesaw with spacers between them. The spacers must be made to a prescribed thickness so the slots are the same width as the fingers. To determine spacer thickness, first measure the tooth width and the blade thickness with a micrometer. To calculate the spacer thickness, double the tooth width and subtract the blade thickness. The spacers can be made from items normally found around the shop, such as Formica. Wafers cut from thin sheet metal or soda cans make good fine-adjustment shims. —Kenneth T. May, Jeanerette, La.

Methods of Work buys readers' tips, jigs and tricks. Send details, sketches (we'll redraw them) and photos to Methods, Fine Woodworking, Box 355, Newtown, Conn. 06470. We'll return only those contributions that include an SASE.

Routing dado joints

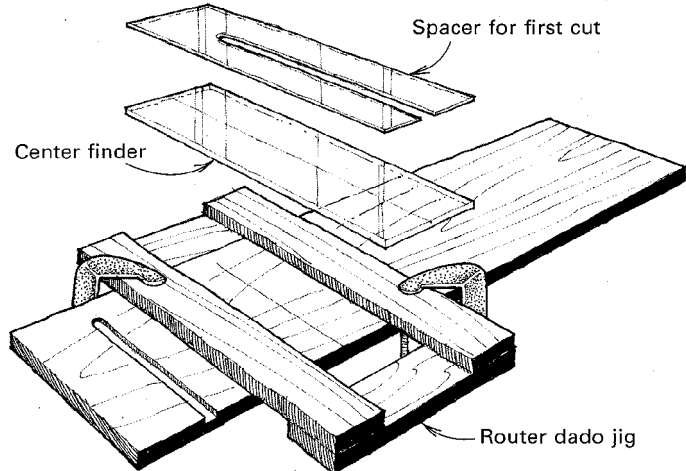

In the high-school furniture-making class I teach, we use a router and a parallel guide like the one shown above to cut most of our dado joints. Even though the guide alone helps reduce errors, we use two simple plastic fixtures to increase accuracy and reduce the number of mistakes made by new woodworkers.

The first fixture is a clear plastic position finder, which we use to locate the guide quickly and accurately on the workpiece. To make one, cut the plastic the same width as your router base and as long as the guide. Then, scribe a centerline the length of the finder. To use it, first lay out the centerlines of the dados on your workpiece. Place the position finder in the guide, move the guide so the scribe line is positioned over the layout line and then clamp the guide in place.

The majority of our dado cuts are $\frac{3}{4}$ in. wide and $\frac{3}{8}$ in. deep, which is too heavy a cut to make in one pass. Rather than reset the routing depth over and over for each cut, we use the second fixture, a $\frac{3}{16}$ -in.-thick piece of plastic, as a spacer for the first cut. Like the finder above, cut the spacer the same width as the router base and the same length as the guide. Cut a 1-in. slot down the middle of the spacer to within a couple of inches of one end. To use, put the spacer between the guide fences, set the router for the full $\frac{3}{8}$ -in. depth of cut and make the first pass. Remove the spacer and make a second pass to the final depth.

—J. K. Blasius, Bowling Green, Ohio

Quick tip: I use a short length of self-sticking, open-cell-foam weather stripping on the end of a popsicle stick to spread glue. Different widths and thicknesses of the foam are commonly available at hardware stores. Throw the applicator away when done.

—Sandy Allen, Santa Cruz, Calif.

Picture-framing clamp

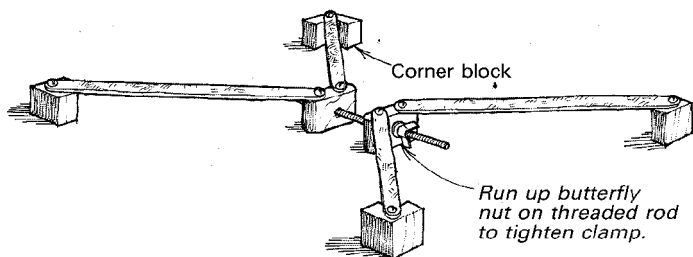

For clamping picture and mirror frames, I have made several sizes of the jig shown above. In use, the corner blocks fit over the mitered ends of the molding. When the wing nut is tightened, equal pull is placed on the four arms, which pull the

miters equally together. For best results, when the clamp is tight, its arms should be at about 90° to each other. This angle depends on the length of the arms in relation to the size of the frame; hence, the various sizes. For frames of unusual proportions, a few assorted lengths of $\frac{3}{8}$ -in. threaded rod give me all the range of settings I need.—C. Robson, Coe Hill, Ontario, Can.

Wooden lathe chuck

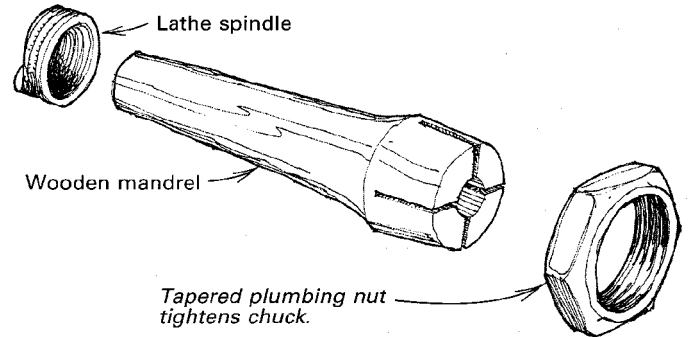

I originally made this wooden lathe chuck to hold pieces of $\frac{1}{4}$ -in. dowel stock. But the design could be sized to fit any dowel or even to serve as a small collet chuck. To make the chuck, first turn a Morse taper on a piece of hard maple to fit your headstock spindle. Tap the future chuck into your headstock and turn a $1\frac{1}{2}$ -in.-long head on the end. The head should be tapered slightly and sized to fit a nut made by sawing an iron pipe bushing in two directly behind the hex flats. To complete the chuck, drill an accurate hole through the center of the head, using a bit in the tailstock center. Then make two opposing sawcuts along the hole to allow for compression. Insert the dowel and tighten the nut, and the dowel will be held firmly. Because pipe threads are tapered, be sure to install the nut large-end first. A little oil on the nut threads will help.

—Walter O. Menning, La Sails, Ill.

Eliminating glue squeeze-out

I discovered this interesting solution to an ancient gluing dilemma while restoring an old drawer. The drawer's guide was glued in place, but there was no glue squeeze-out to be seen. The maker had sawn two shallow sawkerfs into the gluing surface near the edges. When he applied glue to the center section of the guide and clamped it in place, any potential squeeze-out was contained in the kerfs.

—John M. Gray, Syracuse, N. Y.

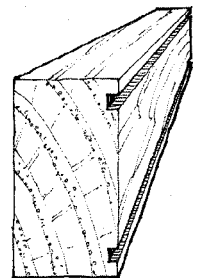

Quick tip: To prevent work from slipping and creeping, glue sandpaper (with contact cement) to the face of your tablesaw's miter gauge.

—Dean Chase, Nevada City, Calif.

Velvet drawer bottoms revisited

Frankly, I think David Miller (*FWW* #67, p. 8) is working too hard. There's another method for installing velvet drawer bottoms and jewelry box linings, using upholstery techniques. The result looks better, allows replacement and can be adapted to the sides and top of the box as well. First cut a piece of thin cardboard slightly smaller than the bottom of the drawer, then cut a piece of velvet a little longer and wider than the cardboard. With the velvet face-down on a table, center the cardboard on the velvet and trim each corner of the velvet at 45° . Apply a bead of quick-drying glue to one edge of the cardboard and fold the velvet's seam into the glue. After the first edge has set for a few minutes, glue the other edges to the cardboard,

stretching the velvet as you go so there are no wrinkles on the face side. Finally, apply a dab of glue to the center of the cardboard back and press the bottom into place in the box.

This technique works well with velvet, felt and leather. It even works with silks and satens, which telegraph glue spots badly and thus can't be glued directly to wood. This approach also works well with shadowboxes and collection displays, because you can mount the display items to the velvet insert with fine wire before placing the insert in the box.

—Ernest B. Shipley, Oakland, Calif.

EDITORS NOTE: Max Schulte of Springfield, N.J., submitted essentially the same method at about the same time.

Assembly squares

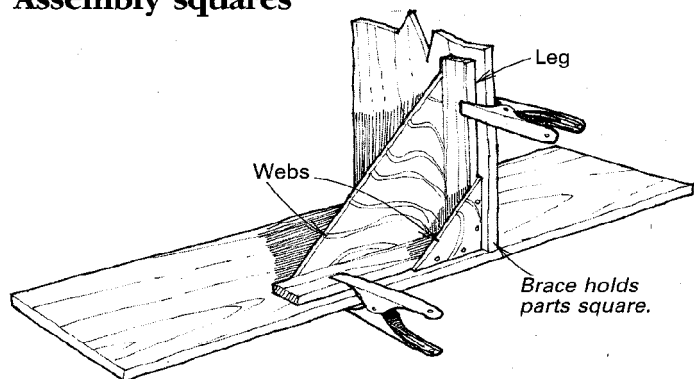

For assembling cabinets by myself, I have a set of assembly squares that I spring-clamp into corners to hold the parts perpendicular to each other. The squares act as a second pair of hands, holding the workpieces square and in alignment until I can spread the glue or drive home the screws. The webs are ¼-in. plywood, and the legs are 1x2s.

—T.D. Culver, Cleveland Heights, Ohio

Hybrid paneling system

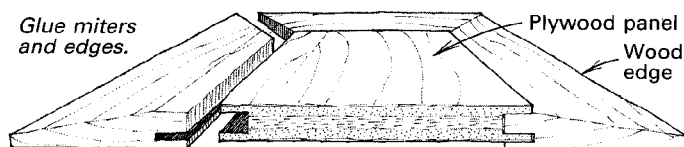

On a recent project that called for Georgian wainscoting on and around a stairway, I devised a way of combining solid-wood edges with ½-in.-thick plywood centers to produce large fielded panels. The approach takes advantage of the superior stability and affordability of plywood while avoiding the unsightly glue layers and voids that show on the beveled edges of all-plywood panels.

To make the panels, first cut all the plywood centers to size. Then make the solid-wood bevel stock for the panel edging. This can be done easily with a thickness planer and a shopmade bed to tilt the stock sideways a few degrees.

The panel centers are fitted to the bevel frame with a double tongue-and-groove joint. To produce this joint, use a ¼-in. slotting cutter on your router table to groove the edges of the plywood panels and a ⅜-in. cutter to groove the edge of the solid-wood bevel stock. The trick in routing the slots is to set the height of the cutter so you leave a ¼-in. tongue on the bevel stock, which will press easily into the slot in the plywood. And conversely, the tongue left on the plywood should press into the groove in the bevel stock.

Now carefully miter the bevel pieces, apply glue to the tongue and tap the frame gently into place around the panel. You may wish to pin each corner with a brad, but there's no need to clamp

the assembly if the tongue-and-groove joints fit correctly.

I used this technique not only for the rectangular wainscoting panels, but also for the parallelogram-shape panels and triangular panels at the side of the staircase. My work was to be painted, but I see no reason why this technique would not look fine with a stained finish.

—William D. Lego, Springfield, Va.

Quick tip: I needed a quick repair on a minor veneer chip, so I tried some iron-on resin sheet from a fabric store—the stuff they sell to iron patches on jeans. I used a warm, not hot, iron and applied some pressure while the patch cooled, much like using a hot-glue gun. This was several months ago and the patch is still holding fine.

—Tom Dewey, Coudersport, Pa.

Flexible hold-in

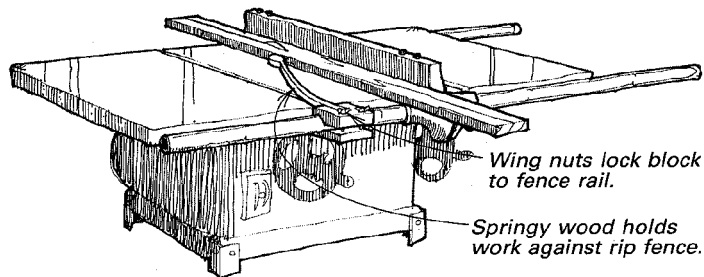

Most featherboards or hold-ins utilize an angled board with numerous sawkerfs cut into one end. The flexibility of these featherboards is pretty limited, so they must invariably be reset after every cut. The alternative design shown in the drawing offers a much greater range of flexibility and requires fewer adjustments as ripping progresses. The bandsawn spring is da-dood into a split block that slides on, and locks to, the rip-fence rail for quick adjustment. The length of the spring and the strength of its action can be tailored to suit. Hickory or pecan are common springy woods that adapt well to this type of use.

—Bert. G. Whitchurch, Hemet, Calif.

Quick tip: The tops of 12-oz. frozen juice cans fit "soup" cans perfectly, making them temporary storage containers with lids.

—Robert E. Wright, Center Sandwich, N.H.

Marking-gauge locking device

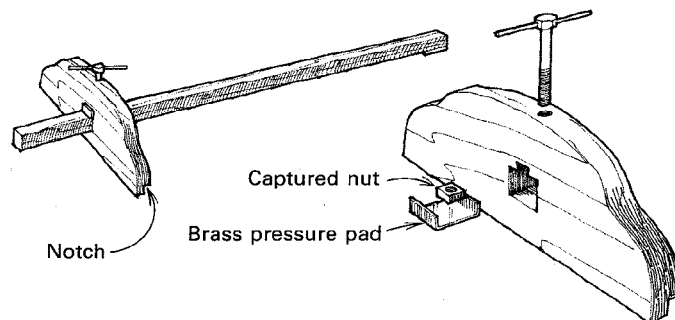

Many of us make marking gauges and other tools that require a beam to be locked where it slides through the fence. A wedge can be used, but a screw is more positive and more accurate. Of course, screws with wooden threads are nice, but the means for cutting them are uncommon in the average tool kit. So here is an alternative. The version shown in the sketch is a panel gauge (as used by Frank Klausz in *FWW* #70, p. 74), with its fence notched to ride the edges of large panels. This raises the beam above the surface of the panel, cutting down friction and increasing accuracy.

For the screw, you need nothing more than an ordinary ⅜-in.

bolt with a square nut. Cut a slot above the beam mortise into which the square nut will slide and be captured. Also enlarge the mortise to allow enough clearance for a pressure pad bent up from 1/16-in.-thick brass. Bend up the ends of the pressure pad high enough to hide the ends of the nut slot. To complete the gauge, drill a hole for the bolt down from the top of the stock into the nut-capturing slot. You may wish to install a 3/16-in. rod through the head of the bolt so it can be tightened without a wrench.

—Percy W. Blandford, Stratford-upon-Avon, England

Quick tip: A good way to get at stubborn areas when stripping a finish is to saturate some coarse sawdust with a mixture of four part alcohol and one part lacquer thinner. As a final step, this can be rubbed into tight spots on spindles or into decorative moldings around panels. The sawdust acts as a mild abrasive and also absorbs the sludge from the old finish. Sawdust residues can be brushed away or vacuumed up easily when dry.

—Ron Fink, Burnaby, British Columbia

Milling radiused corners on tabletops

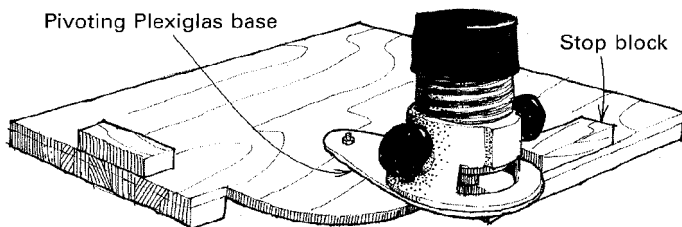

Faced with the prospect of milling 80 identical radiused corners on a run of restaurant tables, I came up with the "Corner King" jig shown in the sketch. It's built from a square of 1/4-in. plywood, with fences attached to the bottom on two sides. A pivoting Plexiglas base was designed to allow a 1/2-in. router to swing through the proper radius (4 in. in this case). Adding stop blocks to the top limited the travel of the bit to 90°.

A nice feature of the jig is that the first pass with the router cuts the jig's base into a perfectly radiused pattern. In practice, I set the jig on a corner, traced the radius pattern directly off the base, removed the jig and trimmed the bulk of the waste with a jigsaw. Then, I screwed the jig to the tabletop and used the router to finish the corner.

—Al Dorsa, St. Croix, Virgin Islands

Cleat-system shop organizer

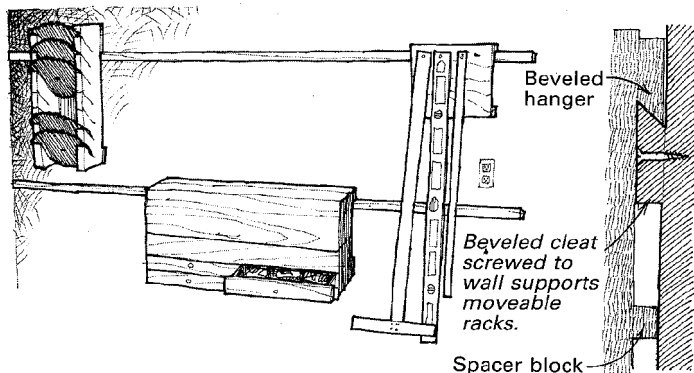

Being a compulsive organizer, I have moved things around in my shop many times and I anticipate more moves in the future. To accommodate all this rearranging, I have come up with a cleat system that makes practically everything in my shop portable. The system consists of two beveled cleats attached to the shop walls. One cleat is attached 40 in. from the floor, a good

working height, and the other at 64 in., a good hanging height. Any item I want to attach to the wall is fitted with a reverse-bevel hanger, as shown in the sketch. I use the system to hang my toolbox, router box and drill box, to fasten a grinder to the wall, to position my work lights and to attach hooks for rules and brooms. I use the cleats to hang everything that can be used in several locations. Later, I plan to build an identical cleat system inside a panel truck so I can transfer equipment between shop and truck quickly and neatly.

—John Loughrey, Madison, Wisc.

Removing paint-filled screws

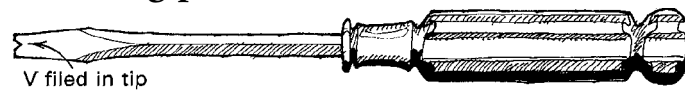

I have been a carpenter all my working life and have covered just about all aspects of the trade. A simple but effective trick that's not often seen is a screwdriver modification for removing screws whose slots have been filled in with paint. File a small V right in the tip of the blade. Now just hammer the screwdriver into the slot and unscrew. The V will allow the tip to penetrate the paint, and it doesn't affect the screw-turning aspects at all.

—Reg Fuller, Turramurra, New South Wales, Australia

Two hole-enlarging methods

To enlarge a hole in wood when you don't have the exact size bit you need, use a fly cutter with a hardwood plug over the pilot bit as a guide. Make a plug the same size as the hole to be enlarged, and wax the plug so it turns freely. If the hole is going to be enlarged only fractionally, cut a slot in the plug's side to hold the cutter bit, as shown.

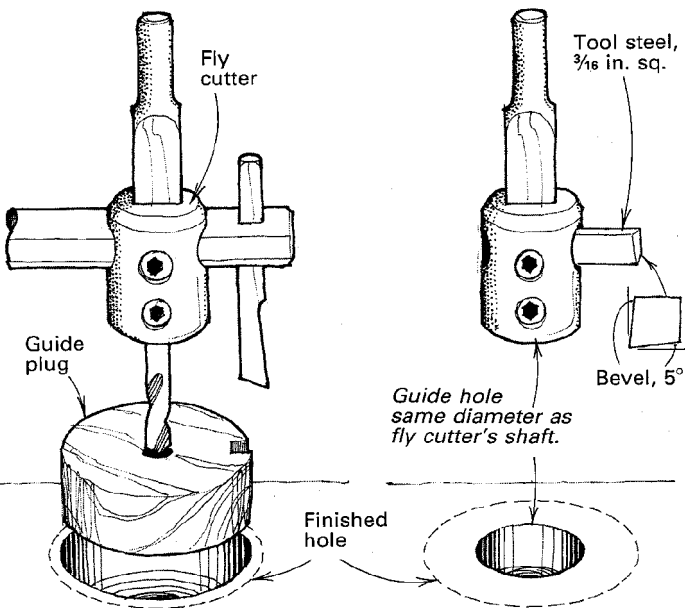

When I needed to drill several precise 2-in. holes and my fly cutter proved unsatisfactory, I thought of replacing the crossbar in the fly cutter with a shopmade cutter, as shown above. I ground a 5° bevel on a length of 3/16-in. tool steel and locked it in place. Then, I drilled a pilot hole the same size as the diameter of the fly cutter's shaft. This device bores clean, sharp holes that are amazingly accurate.

—Samuel W. Pool, Cupertino, Calif.

Methods of Work buys readers' tips, jigs and tricks. Send details, sketches (we'll redraw them) and photos to Methods, Fine Woodworking, Box 355, Newtown, Conn. 06470. We'll return only those contributions that include an SASE.

Making fixed-louver shutters

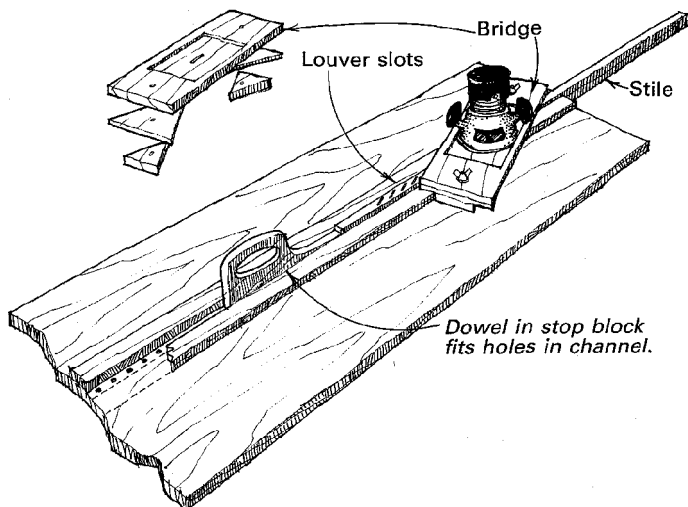

Exterior wood really takes a beating in the subtropical climate of Key West, Fla., where I work. So when a client hired our company to replace his deteriorated pine shutters with longer-lasting redwood, we developed this quick, easy and inexpensive method for building the shutters right on the job site.

A tedious but critical part of shutter construction is routing slots in the stiles for louvers. For this operation, we devised a jig, as shown in the sketch above, that holds the stile in a channel and allows it to be moved in steps as each louver slot is routed. Accurate spacing is ensured by using a stop block and a series of holes 1 3/8 in. apart in the channel. A dowel in the bottom of the stop block fits the holes. The jig is also fitted with a bridge that holds the router above and at 18° to the stile. The bridge may be unfastened and repositioned to cut mirror-image slots in the mating stile. A recess in the top of the bridge allows the router to travel back and forth the precise distance needed to cut each slot.

To rout louver slots in a stile, we first mark off 6 in. at the top and bottom to allow enough room for the rails and waste. We also mark off the center of the stile where we skip two slots to leave room for the middle rail. Then, with the stile located in the jig's channel, we begin routing slots, tipping back the router to start the cut (a plunge router would be great for this job). After repositioning the bridge, we rout slots in the opposite stile. To complete the shutters, we mortise the stiles, cut tenons on the rails and glue up with epoxy and pipe clamps.

—Barb M. Kamm, Key West, Fla.

Angle finder for cutting coves

Set parallelogram jig to desired cove width; place astride blade to determine fence angle.

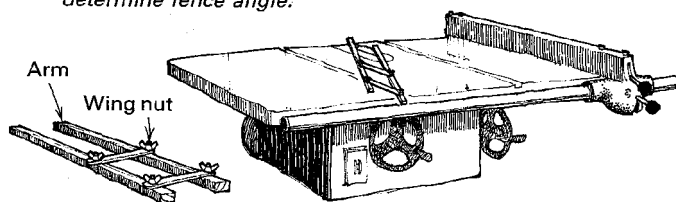

To accurately cut coves on the tablesaw, you must clamp the fence to the table at the correct angle, because the angle determines the shape of the cove. This simple parallelogram device makes finding the correct fence angle easy.

To use the device, simply move the arms apart a distance equal to the desired width of the cove and tighten the wing nuts

to lock the arms at this distance. With the sawblade set as high as the cove will be deep, place the device over the blade and rotate it until the arms contact the tips of the teeth at front and back. The device is now at the correct fence angle. All that remains is to clamp a fence to the saw at the same angle, and taking about 1/16 in. at a pass, begin making incremental cove cuts until the final depth is reached.

—Joe Hardy, Des Moines, Iowa

Quick tip: Recently I was assembling some sliding dovetail joints. As might be expected, they stuck. To find the tight spots, I rubbed the dovetail with chalk. Where the joint was binding, the chalk was rubbed off, indicating high spots that needed to be pared down.

—Dennis Sweeney, Upper St. Clair, Penn.

Wooden spring for outfeed support

I tried using a roller work-support while joining the edges of long, heavy boards, but no matter how carefully I adjusted the height, invariably the work would be marked when the end of the board bumped the roller. What I really needed was a more flexible support that simply helped hold up the front of the

Plywood spring supports work.

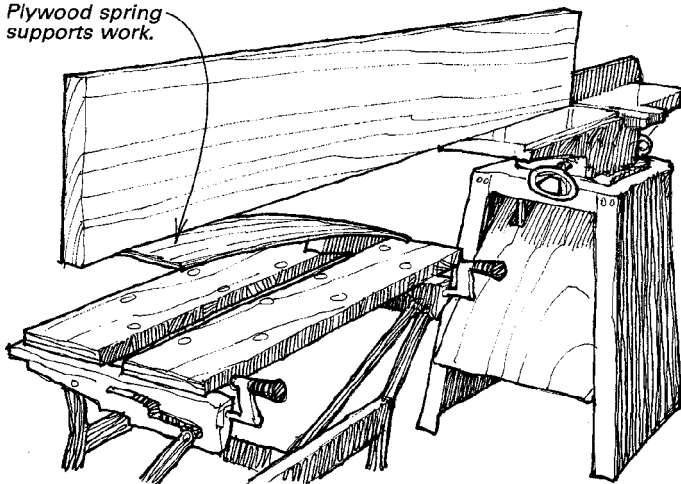

board. The arrangement I came up with consists of a 2-ft.-long, 1/4-in. plywood spring screwed to a 6-in.-long 2x4 clamping spline. I clamp the spring in a portable vise and adjust it so it balances the weight of the work and requires only a slight downward pressure to keep the work flat on the outfeed table.

—Jack Jerome, Nokomis, Fla.

Glue injector

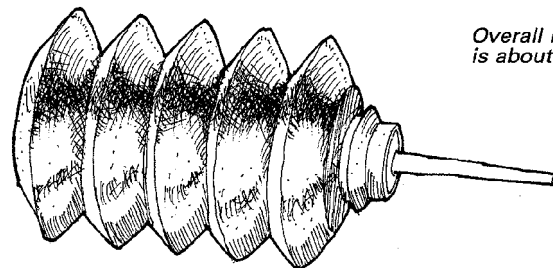

Ask your veterinarian to save you a few of these little accordion squeeze bottles that come filled with an antiseptic used to irrigate puncture wounds. The bottles make great glue or oil applicators in tight places.

—Steve Allard, Carbondale, Ill.

Quick tip: It's long been the rule to buy two rechargeable batteries for a portable electric tool: One battery can sit charging while the other one works. A neighbor recently shared another

example of the "buy two" rule with me. If you have two filters for your shop vacuum, you can use the fresh one to clean the embedded dust out of the old one, thus avoiding a typically miserable job.
—Dan Miller, Elgin, Ill.

Spindle tapering jig

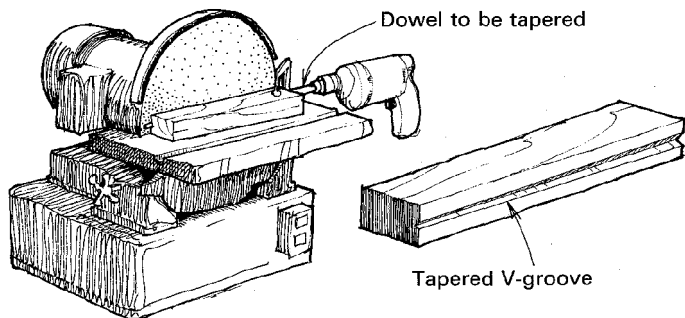

Recently I needed a quantity of tapered wood rods to make drop spindles for spinning wool. The spindles' diameter had to taper from 1/2 in. to 1/4 in. evenly along their 12-in. length. Rather than attempt to turn these tiny spindles on the lathe, I designed the jig shown above, which worked perfectly.

First I selected a 12-in.-long chunk of 1 1/2-in.-thick hardwood for the sanding guide and sawed a 1/2-in.-deep V-groove into one edge. After cutting the groove, I ripped the guide at a slight taper so the groove was only 1/4 in. deep at one end. To use the guide, I clamped it to the worktable of a disc sander, with the grooved edge almost flush against the disc. Then I chucked a length of dowel in an electric drill, and with the drill at slow speed, guided the dowel into the V-groove. After a little practice and some trial-and-error setting of the guide, I was able to make perfect tapers every time.

—Bert. G. Whitchurch, Hemet, Calif.

Quick tip: I have finally found the perfect spot to keep my steel carpenter's square: It hangs on the molding around the door to my shop.
—A.E. Waterhouse, Redding, Conn.

Carcase dadoing jig

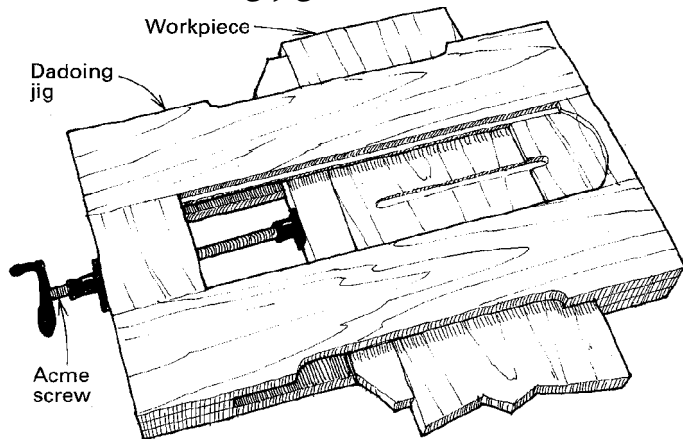

The homemade dadoing jig illustrated in Christian Becksvoort's article "Building a Chest of Drawers" (*FWW* #68) is similar to the one I made several years ago. Mine differs in one respect that I think improves the jig. I purchased an Acme screw, which is often used in constructing book, cheese or juice presses and is available through many tool catalogs. I installed the screw as shown to make the positioning and clamping of the jig quick and accurate—certainly better than using C-clamps.

—Charles Leik, Great Falls, Va.

Detachable vise pads

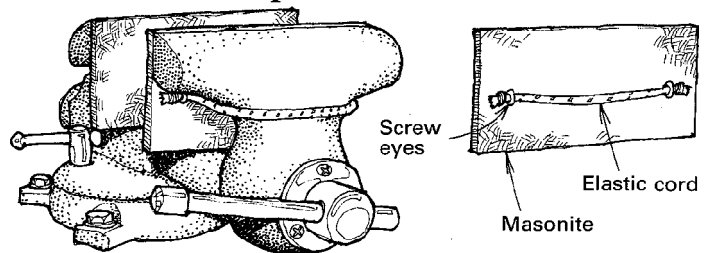

These easy-to-make jaw pads enable me to adapt my machinist's vise for woodworking, and just as quickly, to switch it back to metalworking. To make the pads, cut two 1/4-in.-thick Masonite or hardwood blocks as wide as the vise jaws and as tall as the distance from the top of the jaws to the vise screw housing. Thread a short length of 3/16-in. elastic cord through two screw eyes on the back of the pads to hold them to the jaws. Secure the ends of the elastic cord by wrapping them with 20-gauge steel wire.
—George A Ferrell, Huntsville, Ala.

Quick tip: If you do not have a round slipstone to fit the flute of a gouge, wrap some 600-grit wet-or-dry sandpaper around a dowel of the correct diameter. This makes a very handy hone.
—William E. Richie, Mechanicsburg, Penn.

Sliding measuring sticks

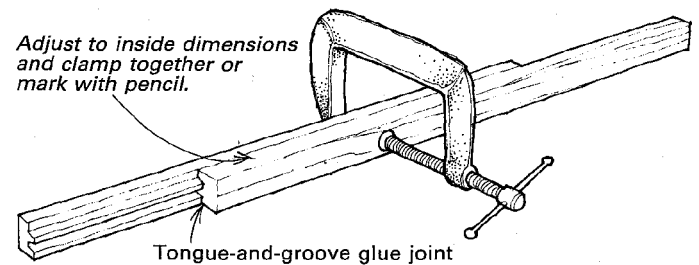

The next time you're running tongue-and-groove glue joints, rip off some sticks about 3/8 in. thick, with the joint profile on one side. Put the two sticks together to make a sliding measuring stick that can take inside measurements accurately. The measurements can be registered by marking across both sticks with a pencil or by clamping the two sticks together with a small C-clamp. The measuring stick is especially useful for checking a door opening for consistent width from top to bottom.

—Robert M. Vaughan, Roanoke, Va.

Perfect half-lap joints

The half-lap joint is a strong, useful joint for cabinet frames, but setting up the saw so it cuts away exactly half from each piece can be frustrating. Here's a method for setting the blade height that's fast and foolproof, and it doesn't require jigs or measuring. Grab a waste piece of the frame stock, and with your tablesaw's blade height elevated to less than half the stock thickness, pass the stock over the saw on both sides to leave a thin center section. Raise the blade a little and make a second pass. Continue raising the blade, taking cuts on both sides, until only the slightest membrane of wood remains in the center. You have now achieved the perfect blade-elevation setting. I waste the lap area with repeated passes, then clean up any small ridges and saw marks with a rasp.
—Duane Waskow, Cedar Rapids, Iowa.

Methods of Work buys readers' tips, jigs and tricks. Send details, sketches (we'll redraw them) and photos to Methods, Fine Woodworking, Box 355, Newtown, Conn. 06470. We'll return only those contributions that include an SASE.

Two rip-fence straddling jigs

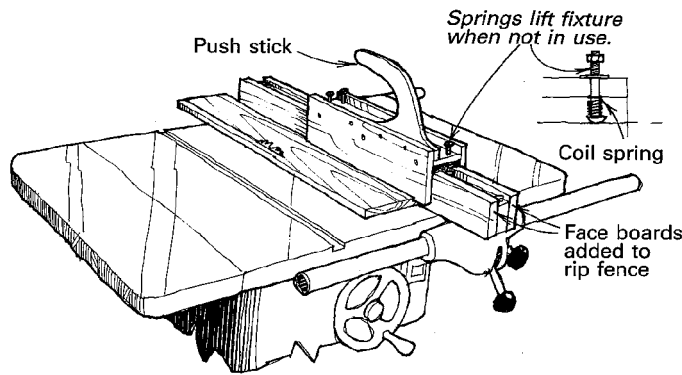

This fence-straddling push stick was originally designed to fit a Biesemeyer fence, but it could be adapted to practically any fence fitted with auxiliary face boards, as shown in the sketch. For added convenience, I installed plungers made from coil springs and bolts to raise the push stick when not in use.

—Bill Hatch, Greensboro, N.C.

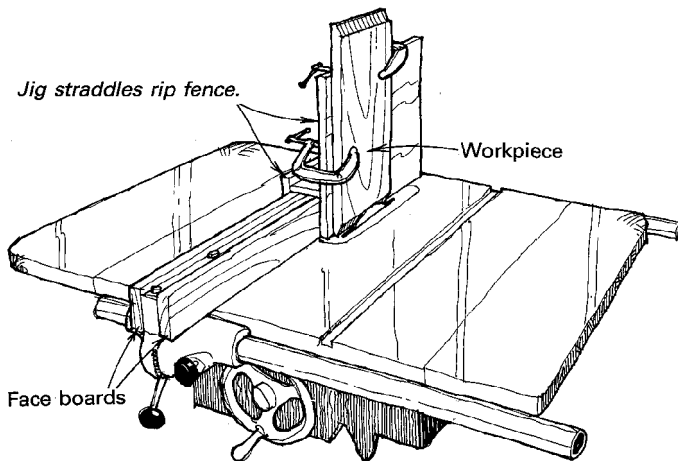

This jig, above, is designed specifically for making those steep angled cuts on the edges of long workpieces, as in making fielded panel doors. If you've tried sliding a wobbling workpiece vertically along the fence, while watching to make sure the tapered end doesn't fall through the space in the saw insert, you'll immediately recognize the advantages of this jig. With it, you can make a smooth, controlled, burn-free cut.

Dimensions aren't critical, just make sure the jig slides smoothly on the rip fence. The face of the jig can be large or small depending on the size of the workpiece. It can be fitted with a vertical fence if needed. Just C-clamp the workpiece to the face of the jig, then slide the jig past the blade.

—Alfred W. Swett, Portland, Maine

Quick tip: If your screwdriver tip won't grip the slot of a hard-to-remove screw, put a little valve-grinding compound in the screw slot.

—Steve Daechsel, Abbotsford, B.C., Canada

Hot-melt adhesive by the sheet

When I couldn't find sheets of hot-melt adhesive for my veneering project at the store where I bought the veneer, I went looking elsewhere and found it at a fabric shop. The sheet adhesive comes in two forms: fusible web and transfer web. Fusible web is simply a sheet of hot-melt adhesive that you cut to size, place between the parts and press with a hot iron to fuse. With this type, there may be a bit of squeeze-out around the edges of the veneer.

By contrast, the transfer-web adhesive is applied by first melting the adhesive to the back of the veneer. Then you peel off the backing paper, cut the veneer to size and fuse the veneer to the ground with a hot iron. This approach seems to result in a neater glue job. To avoid ironing dirt into the wood, place a clean sheet of paper between the iron and the veneer. A sandbag will apply the small amount of pressure needed to hold the veneer in place while the glue sets.

The fabric-store adhesive works just fine, and at \$1.70 per yard, I certainly can't complain about the price.

—Gerald W. Edgar, Renton, Wash.

Quick tip: During the summer, I wear shorts while turning, and that lets the sawdust fall annoyingly into my shoes. To prevent this, I bought a pair of hiking gaiters at the local sporting-goods shop.

—Helga Wink, Nashville, Tenn.

Thickness-planing short pieces

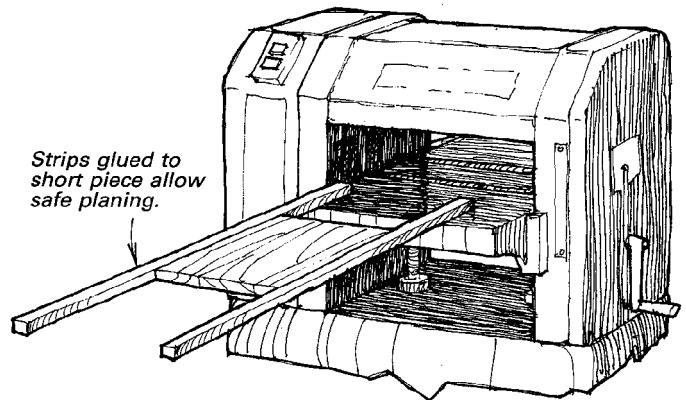

Because feeding short boards through the planer may result in snipes and even kickbacks, the operation should be avoided. But when the job is necessary, here's a way to make it less risky. Glue two scrap outriggers to the edges of the piece to be planed, as shown in the sketch. These scraps, because they extend several inches beyond the ends, will stabilize the short board as it enters and leaves the planer, thus reducing the chance of sniping. When the desired thickness is reached, saw off the scrap outriggers and run the board's edges over the jointer to clean them up.

—Bill Clark, Bakersfield, Calif.

Quick tip: If you run into burning problems when drilling hardwoods, try lubricating the hot bit by letting a little beeswax melt on it.

—John Wiznak, Victoria, B.C., Canada

Sliding dovetail jig

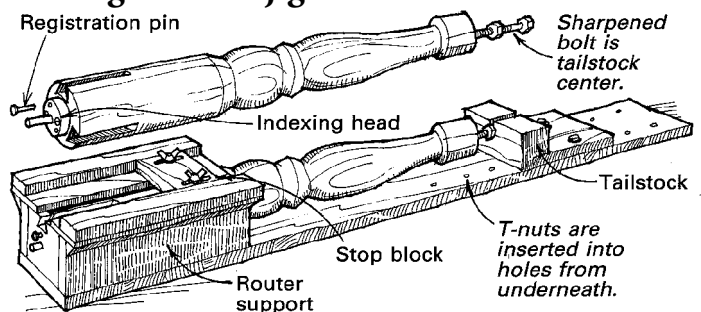

I use this jig for routing the sliding dovetail housings for the legs of small pedestal tables and stands. It's fast to set up and very accurate. I made the jig's index head from a 1/2-in.-thick aluminum plate bandsawn into a circle, but you can make it as easily out of a thick piece of hard maple. I tapped the center of

the index head to receive a short length of 1/2-in.-dia. aluminum rod with one end protruding slightly and pointed to act as a center. Three indexing holes are bored through the head to correspond with the dovetail housings to be cut in the pedestal. A registration pin pushed through the face of the router support seats in one of these holes, positioning the pedestal for routing.

I use a 3/4-in. dovetail cutter in my router to cut the housings and install an adjustable stop block on the router support to keep the housings the same length. —Eric Schramm, Los Gatos, Calif.

Hemispherical sander

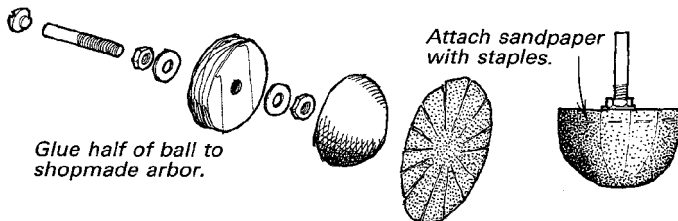

This little device, which works especially well for sanding concave interior surfaces, can be easily produced in the workshop. Start with a sponge-rubber ball, the kind available at toy stores in various diameters from 1 in. to 3 in., and carefully cut the ball in half. Now saw the head off a 3/8-in. carriage bolt. Using jam nuts, screw the bolt to a plywood disc the same diameter as the sponge-rubber hemisphere. Hollow the hemisphere to accept the jam nut and attach it to the plywood disc with hot-melt glue or silicone adhesive. Prepare an abrasive disc to conform to the hemisphere by cutting several radial slots at equal distances, as shown. Staple the abrasive paper to the wooden disc or hold the paper in place with a hose clamp. —Donald F. Kinnaman, Phoenix, Ariz.

Quick tip: Cardboard tubes from the centers of newspaper rolls make good drums for lathe-mounted thickness sanders. Just turn end plugs and epoxy in place. My drum is 6 in. in dia. and 3 ft. long, with 1-in.-thick walls. Newspapers give them away for the asking. —J. Mark Fineout, Terrell, Tex.

Dust collector

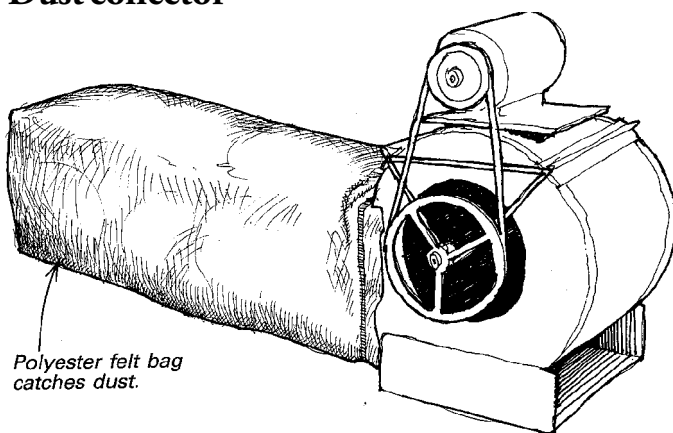

When I went shopping for a shop vacuum system, the culmination of the salesman's pitch concerned the unit's large blower that sucked the dust out of the entire shop. I realized then that I did not need another vacuum in the shop, simply a dust eliminator. Turning to an article by Mac Campbell in *FWW on The Small Workshop*, I found the key: a bag made from polyester felt. The material, available from most large retail fabric outlets, allows air to flow through, but it catches dust, similar to the way a filter bag works in a vacuum cleaner. I combined a homesewn bag with a discarded squirrel-cage blower, and the rest is history. You

would not believe the dust this thing sucks up. I keep the unit on the floor and direct my sweepings toward the inlet; when I'm sanding, I stay close to the blower. All the dust that normally stays in the air for minutes and powders every inch of the shop is sucked up instantly.

—Thomas C. Turner, St. John's, Newfoundland, Canada

Quick tip: To prevent your oilstone box from sliding around the bench while you sharpen tools, drive a small finish nail near each corner. Clip each brad short and sharpen it to a point so it will grip. —P. W. Blandford, Stratford-on-Avon, England

Miter gauge for plywood edgebanding

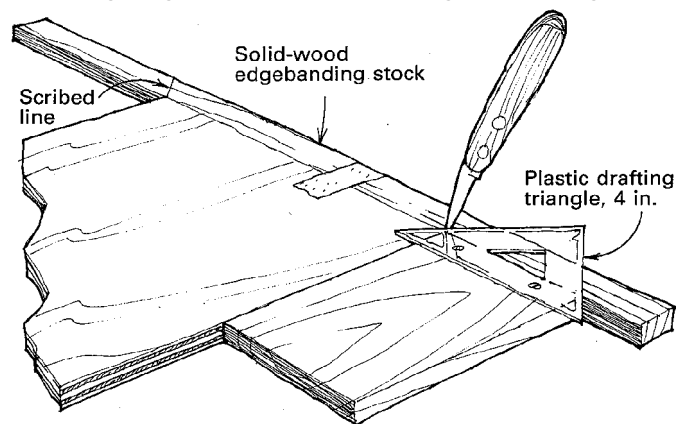

Solid-wood edgebanding is often used around plywood doors and tabletops to cover the edge laminations. But measuring, aligning and scribing the eight 45° miters on the banding is a tedious job, because the banding's length and the miters' angles must be perfect for everything to fit. This little gauge eliminates the measuring and allows you to mark the miters right from the workpiece.

To use the jig, first tape the banding stock in place on the edge. Slide the jig into the corner where the work and the banding stock meet, and scribe the 45° miter with a sharp knife. Move to the other end and repeat. If the jig has been accurately made, you'll have perfect scribe lines for cutting miters on the banding.

To cut the miters, I use a standard plywood jig with rails on the bottom that run in the miter-gauge slots on my tablesaw.

—L.A.D. Colvin, Satellite Beach, Fla.

Plate joinery on a budget

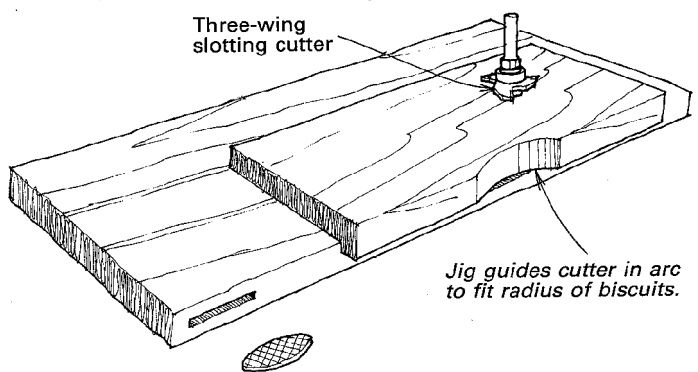

When my hankering to take advantage of quick biscuit-joint systems ran up against the high cost of the required machinery, I looked for a cheaper approach. My solution was to use a wing slotting cutter in a router to make the kerfs for the standard biscuits. An Amana three-wing slotting cutter (available from WS.

Jenks & Sons, 1933 Montana Ave., N.E., Washington, D.C. 20002 for about \$15) can cut a 3/32-in.-wide, 1/2-in.-deep slot the same as any biscuit joiner.

The only problem is that the three-wing cutter's radius is just under 1 in., while the radius of the biscuit joiner's sawblade is 2 in. Because of the smaller radius, the profile of the routed slot will not mate perfectly with the semi-circular edge of the biscuit. Although this mismatch will not affect the assembly or strength of the joints, it can be eliminated by constructing a simple jig, as shown in the sketch. The jig guides the cutter through a 2-in. arc and also sets the depth of cut.

—Richard Fryklund, Arlington, Va.

Quick tip: Arm & Hammer washing soda cleans pitch and gum from sawblades. Dissolve about half a cup in a shallow pan of hot water large enough to hold the blades, and let them soak a few minutes. Rinse with hot water and dry. This will not harm the blade or your hands, and as a bonus, it will also help keep the drainpipes clean.

—Gerald Szeplinski, Greendale, Wisc.

Fixed-position marking gauges

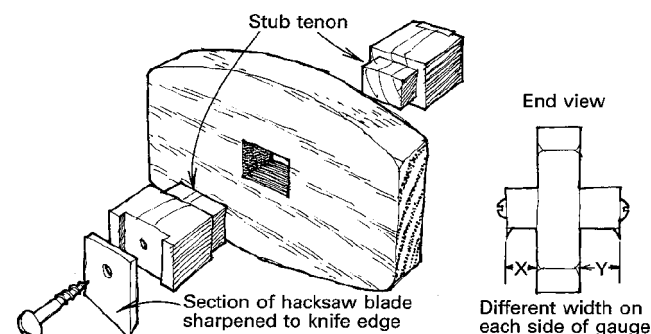

Using fixed-position marking gauges saves me time and tedium while laying out. Here's how I make them: Cut several short pieces from a hacksaw blade. Drill a hole through each blade section and bevel and sharpen one end to a knife edge. The body of the gauge is a 3-in. by 5-in. block with a mortise in its center. Cut stub tenons on the ends of two pieces of 3/4-in. by 1-in. hardwood so they each can be glued into the mortise from opposite sides of the body. Cut each of these two pieces to length so that a section of hacksaw blade is screwed into a notch in the end, the knife edge will be the desired distance from the body of the gauge. Mount the blade with the bevel facing the block. This way the blade will pull the block into the work and stay on track. When finished, mark the gauge's measurements so you can quickly find the size you're looking for.

—Dennis R. Mitton, Gig Harbour, Wash.

Quick tip: If your sandpaper tends to clog quickly because of gum or glue, a quick pass with a file card or wire brush will extend its life.

—Chris Dallsmore, Salt Lake City, Utah

Box-lid trick

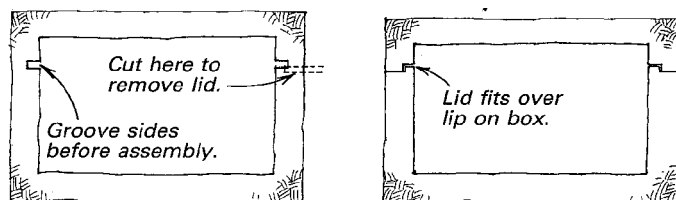

When I make small boxes, I assemble them in one piece, including the lid. Then when I cut the lid off, it will match the box exactly. When I want an undercut on the lid to fit over a lip on

the box, I use a variation of the one-piece technique. First, before assembly, I cut a 1/8-in.-wide groove in the inside face of each of the box's sides where the top of the lip is to be. After the box has been assembled, I use a narrower blade to cut off the lid. I offset the second lid-removal cut from the inside groove, as shown, to produce a lip that nests into the lid.

—F.B. Woestemeyer, West Chester, Penn.

Clamping perch for irregular shapes

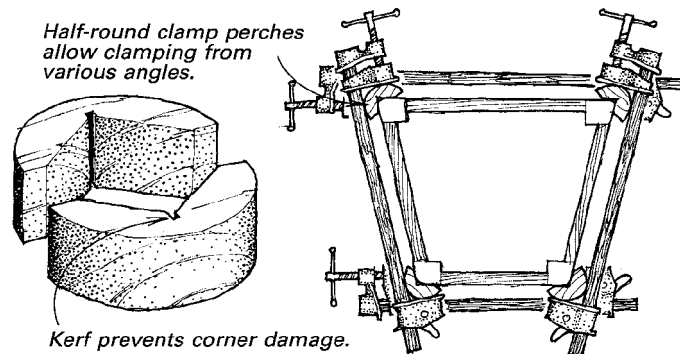

To clamp up chair frames and other irregular shapes, I use semi-circular clamping perches like the ones shown in the sketch. To make the perch, cut a 3-in.-dia. circle from a 2x4 with a large hole saw or fly-cutter. On the bandsaw, halve the circle with the grain and make a V-cut in the flat side to match the angle of the corner of the piece being glued. An extra kerf at the apex will prevent the block from crushing any sharp edges or from being glued to a mitered corner. The round surface will accept clamping from any angle, even crossclamping.

—John M. Gray, Syracuse, N.Y.

Quick tip: Smoothly planed wood can be slippery to get a grip on when feeding a machine. Licking your fingertips greatly increases the control.

—E.C. Kimball, McCall, Idaho

Holding push sticks with Velcro

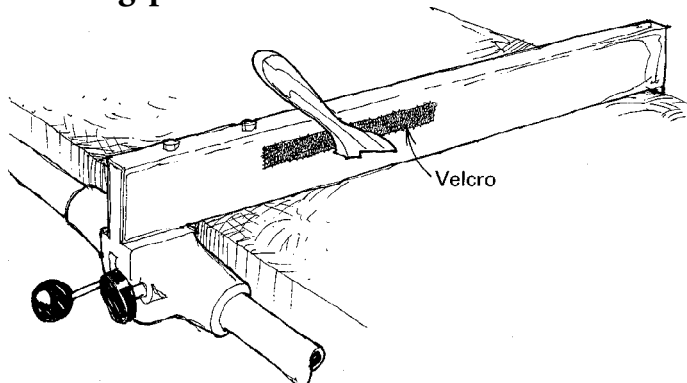

Frustrated at never having my push sticks on my tablesaw when I need them, I glued a strip of Velcro on the right side of my rip fence and the mating Velcro material on the sides of my push sticks. The push sticks now stand at attention on the rip fence, ready to be grabbed when needed. Most Velcro now comes with a peel-off sticky back that should fasten the material well enough. This tip could be used for many accessories and tools around the shop.

—David Crawford, Brownsboro, Tex.

Methods of Work buys readers' tips, jigs and tricks. Send details, sketches (we'll redraw them) and photos to Methods, Fine Woodworking, Box 355, Newtown, Conn. 06470. We'll return only those contributions that include an SASE.

Sharpening jointer knives

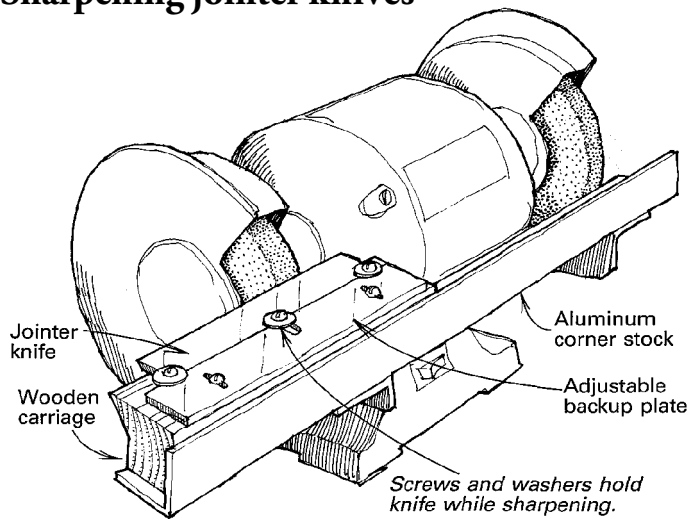

Although I tried several of the jointer-knife sharpening methods published in this column, none worked well for me. One day, while looking at my bench grinder, I was hit with the idea that if the two tool rests were connected, they would provide an ideal support for a sliding sharpening carriage, even if only one abrasive wheel was used for the actual sharpening. To implement my idea, I spanned both tool rests with a length of 1-in. by 2-in. aluminum corner stock, letting one end extend beyond one of the rests. I fastened the corner stock to the tool rests with flat-head machine screws and wing nuts. Then, I milled a sharpening carriage from hardwood to the profile shown in the sketch so it would fit around the wheel's arc. On top of the carriage there's an adjustable aluminum backup plate and three screws and washers to hold the knife to be sharpened. The carriage's dimensions are such that the blade bevel is ground at a 30° angle.

To use the carriage, install the first knife with the backup plate adjusted so the knife just touches the wheel. Slide the carriage past the wheel with constant light pressure directed downward and backward toward the aluminum guide. For the first few passes, the downward pressure should be minimal. For successive passes, I move the blade toward the wheel by shimming with one, then two and eventually three strips of writing paper between the vertical side of the aluminum guide and the back of the wooden carriage. You might say this is crude, but it works just fine.

—Henry R. Jaekel, P.E., Nevada City, Calif.

Quick tip: A local Mennonite woodworker taught me to quickly slicken a sticky saw table by rubbing it with a piece of waxed paper.

—Eric Haarer, Mason, Mich.

Screw-drive centers

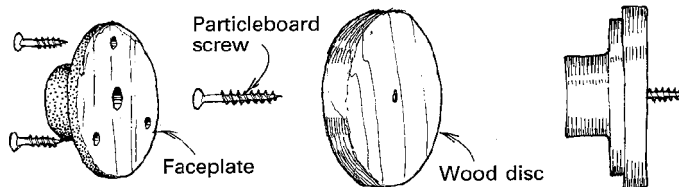

You can make all sorts of custom screw-drive centers for the lathe quickly and inexpensively by utilizing particleboard screws. These screws, which have only recently become commonly available, feature large, wide threads with tremendous holding power. If your local hardware store doesn't carry them, try the Woodworkers' Store, 21801 Industrial Blvd., Rogers,

Minn. 55374-9514; (612) 428-2199.

To make a screw drive, mount a piece of wood to a small faceplate, turn a disc to the desired diameter and mark the center. Now remove the disc from the faceplate, drive the particleboard screw through the disc from the back and remount. The combination of the wide-thread screw and the wood-to-wood friction will give the drive good holding power.

—Ken Picou, Austin, Tex.

Quick tip: Dowel pins need grooves for glue to escape. Instead of cutting grooves, I compress them by tightening the dowel in the ½-in. chuck on my drill press. Dowels so treated tend to swell up again when glue is applied, locking themselves tightly in place.

—D.R. Smith, Miami, Fla.

Trammelheads for occasional use

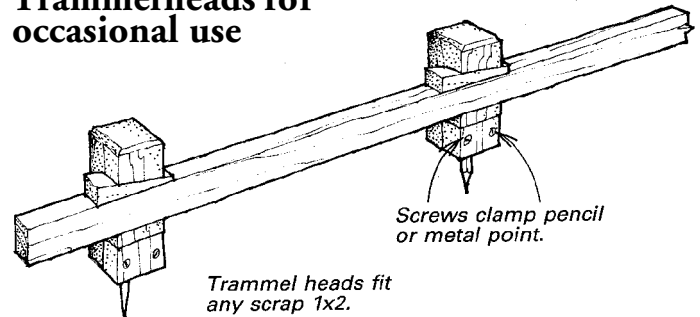

Faced with the occasional need to draw large-radius circles, I made a pair of wooden trammel heads that will fit on any available scrap 1x2.

Each head is 1¾ in. sq. in section, with a notch to accept the beam and a wedge for tightening. A clamping block at the bottom of each head will take a steel spike or a pencil. To make the clamping block, drill a ¼-in. hole in the center of the bottom, then cut away a portion of the head halfway through the hole. Drill the block for two tightening screws.

—Percy W. Blandford, Stratford-upon-Avon, England

Quick tip: A small sheet of ⅛-in.-thick rubber carpet pad—the kind used to keep Oriental rugs from slipping—will both protect the top of your workbench and keep your work from sliding about.

—Chuck Lakin, Waterville, Maine

Sliding motor mount

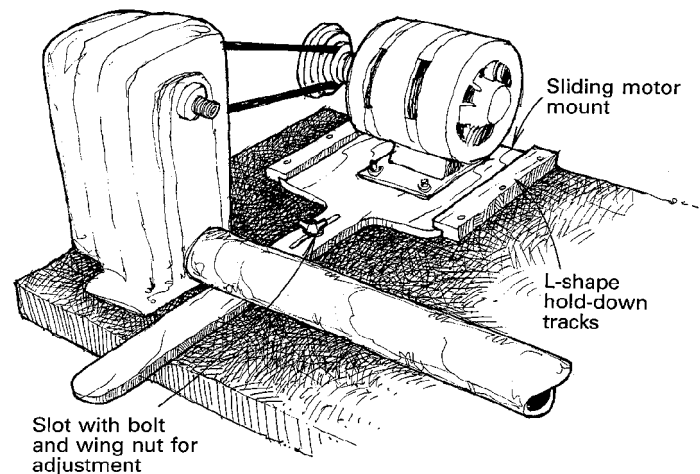

This sliding motor mount for the lathe offers several advantages over the usual hinge-type mount. The device prevents the motor from jumping when a lathe tool gets hung up in the work, and it enables belt tension to be adjusted and remain constant when

set. The mount consists of a plywood paddle on which the motor is attached and a couple of L-shape hold-down tracks. A slot in the paddle arm allows the mount to be locked at any position with a wing nut or to be loosened by hand for moving the belt to a different pulley. —Charles W. Whitney, Mount Vernon, Ohio

Shop-built bandsaw fence

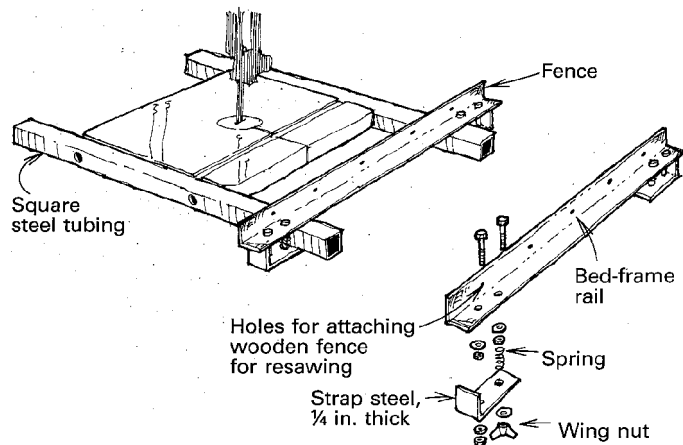

When I purchased my Delta 14-in. bandsaw, I decided not to buy the factory rip fence, because it clamps to the saw table only at one end. I do lots of hardwood resawing and believe that an accurate resaw requires a rigid fence clamped to the saw table at both the front and back.

Using standard hardware-store items, pieces from a tempered steel bed frame and lengths of 1½-in. cold-rolled square-steel tubing, I assembled an extremely sturdy, quickly adjustable fence for under \$15. The fence's construction doesn't require any welding, so it can be built and installed in an evening or two. The design allows the fence to be used on either side of the blade and to be angled slightly, as needed, to match the blade's natural line of cut. I screw a taller wooden fence to the angle iron for resawing wide boards. Construction dimensions may be readily altered to suit the maker's saw.

—Donald G. Sterchi, Bowling Green, Ky.

Quick tip: The best cleaner I know of for clogged sharpening stones is Easy-Off oven cleaner. This opens the pores much better than kerosene. —George Allen, Greenwich, Conn.

Laying out equidistant intervals

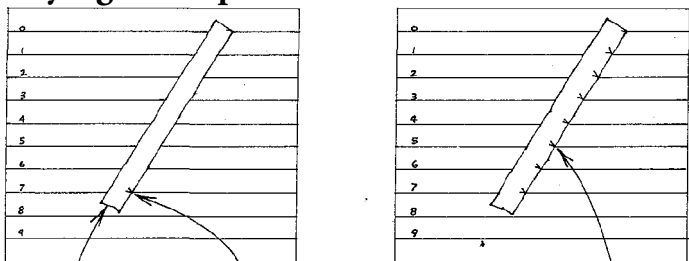

Lay tape diagonally across lined paper beginning on line 0. Mark that denotes circumference

Mark where lines intersect tape.

Here's an addendum to Randall Bishop's tip for using tape to divide the circumference of a circle into equally spaced intervals (FWW #65, p. 12). Bishop recommended wrapping tape around a disc to determine the circumference, then unwrapping the tape, laying out the intervals on the tape and rewrapping the tape to transfer the intervals to the disc. The question Bishop didn't answer is once you've got the tape off the disc, how do you divide

it into the desired number of intervals? Well, here's how:

First draw a series of parallel equidistant lines across a large sheet of paper. The distance between the lines should be slightly less than the smallest interval you will normally use. Number the lines starting with line 0, 1, 2, 3 and so on. Now wrap the tape around the disc, mark where the ends overlap and remove the tape. Assuming the number of desired intervals is seven, for example, you would lay the tape diagonally across the sheet so that line 0 intersects one end of the tape and line 7 intersects the mark denoting the circumference. Now mark where each intermediate line intersects your tape for accurate equidistant intervals without measuring. —Kathleen Wissinger, Elkton, Va.

Quick tip: You don't have to steam an entire length of stock if you only want to bend part of it. Just wrap the section you want to bend in a damp cloth and apply a hot household iron to it. —Chuck Lakin, Waterville, Me.

Trimming edgework

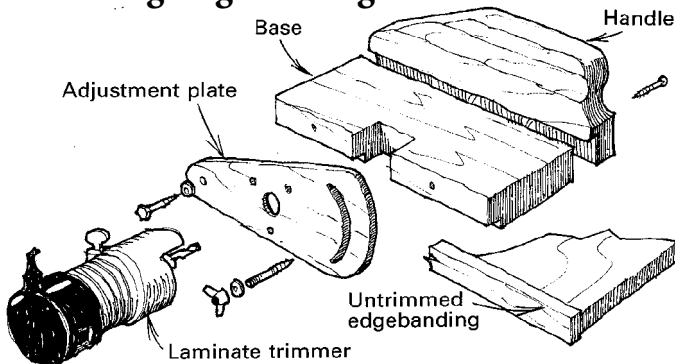

Trimming solid-wood edgework on plywood with a plane or belt sander can be a trying task, so I designed this simple trimmer fixture, which holds a horizontally mounted router. An adjustment mechanism allows the router's bit to be adjusted up or down so it cuts the banding flush with the plywood. Instead of a full-size router, I use a Porter-Cable laminate trimmer, which provides plenty of power for trimming the ¼-in.-to ¾-in.-thick banding I use. I've found that an Onsrud ¼-in., two-flute spiral bit gives a smooth, splinter-free cut that's ready for finish-sanding.

—Warren W. Bender Jr., Medford, N.Y.

Quick tip: If your ¼-in. split-ring router collet sticks, making bit removal difficult, apply a thin film of paste wax to the outside surface. —Steve Spoltman, Dayton, Ohio

Pipe handles for bowl gouges

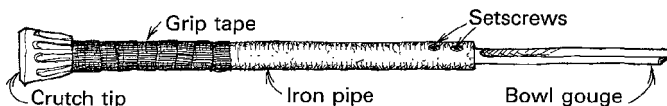

A steel pipe makes a nice handle for high-speed steel bowl gouges. It is not only heavier and more stable than a wooden handle, but it also allows the gouge to be adjusted in or out, depending on the application. Drill and tap two holes for setscrews near the end of the pipe for adjusting and securing the gouge. To improve the grip, wrap the last few inches with tennis-racquet grip tape and put a rubber crutch pad on the end of the pipe. —Earl R. Rice, Augusta, Ga.

Methods of Work buys readers' tips, jigs and tricks. Send details, sketches (we'll redraw them) and photos to *Methods*, Fine Woodworking, Box 355, Newtown, Conn. 06470. We'll return only those contributions that include an SASE.

Turning tiny spheres

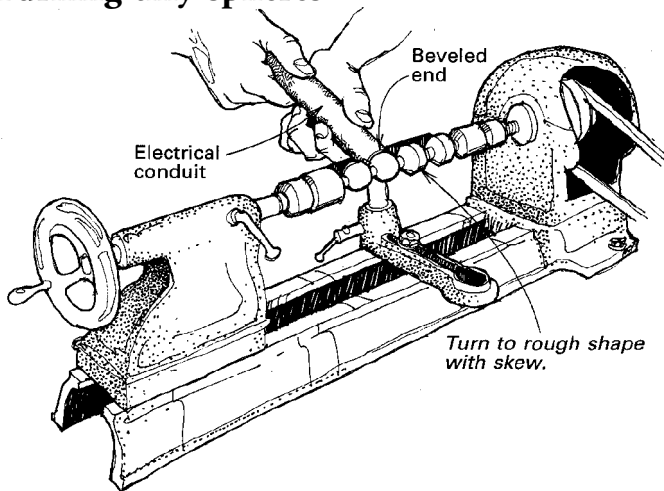

The next time you need several small spheres for a project, try this technique. On a cylinder turned slightly oversize, lay out the number of balls you want, and with a parting chisel, make a cut to separate each ball segment. Be sure to leave at least a 3/8-in.-dia. section between the segments so the workpiece won't break.

With a skew, turn the balls to a rough spherical shape. Now take a section of thin-wall electrical conduit with a sharpened end and slip it over each rough sphere as it turns in the lathe. The conduit will cut the sphere to final size and give you a perfectly round ball. Be careful not to push the conduit too hard, or you will cut through the wood separating each ball.

—Donald F. Kinnaman, Phoenix, Ariz.

Quick tip: A 12-in.-dia. pizza pan can be quite handy around the shop. Use it as a tub to clean your circular saw blades, to keep small parts from rolling off the bench and, with a sheet of non-slip rubber in the bottom, as a basin for sharpening with Japanese waterstones.

—Mike Hipps, Minneapolis, Minn.

Single-setup routed drawer joint

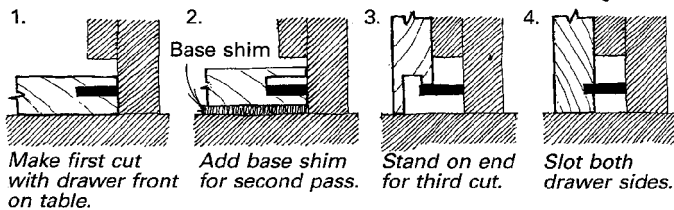
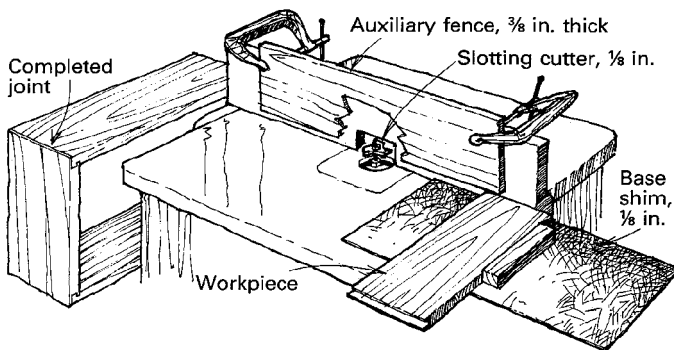

Claude Graham's article on production drawermaking (*FWW* #72, pp. 82-85) prompted me to send this single-setup solution for routing tongue-and-rabbit drawer joints. The setup uses a standard 1/8-in. slotting cutter chucked in a router that's mounted under a router table. You'll also need a piece of 1/8-in.-thick Masonite for

a base shim and a length of 3/8-in.-thick material for an auxiliary fence. Adjust the height of the cutter so the slot starts 1/2 in. above the router table, and adjust the fence so the slot's depth is a shade over 1/2 in., (this is usually the full depth of the cutter). Clamp the auxiliary fence to the main fence, 3/4 in. above the table so a 1/2-in. drawer side and the base shim can slide underneath.

The sequence of cuts is shown in the sketch. Three passes will produce the tongue and rabbet on the drawer fronts and backs. One pass will produce the groove on the drawer sides. Although it's not shown, you can also use the same setup to groove the drawer sides to receive the bottom. Screw the auxiliary fence to the tool's fence so you can remove the clamps for clearance and make two passes, one against the table and another using the base shim. The result will be a 1/4-in. groove 1/8 in. from the bottom of the drawer side.

—Brad Schwartz, Deer Isle, Maine

Quick tip: Graphite-impregnated canvas cemented to the platen of a stationary belt sander greatly reduces friction and improves the speed and quality of sanding. It costs about \$8 per yard from Derda Inc., 3105 S. U.S. 31-33, Niles, Mich. 49120; (616) 683-6680.

—Tom Irvine, Williamston, Mich.

Roller support for crosscutting

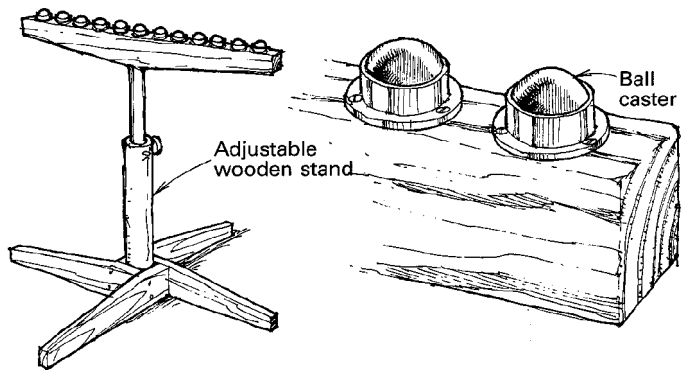

Although there are many freestanding roller stands available for supporting work being ripped on the tablesaw, I've never seen a similar support for crosscutting. The support I developed has served me well in both ripping and crosscutting. Its principal component is a unique ball-shape caster (available from The Woodworkers' Store, 21801 Industrial Blvd., Rogers, Minn. 55374-9514). The caster rides on ball bearings, allowing smooth movement. Keep them clean and free from sawdust or they'll clog and won't run freely. The wooden stand is adjustable and has a weighted base.

—William A. Lemke, Hendersonville, N.C.

Cutting rosettes with a fly-cutter

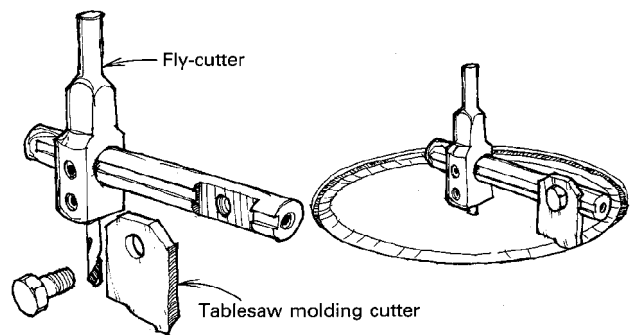

Here's how to convert a common drill-press fly-cutter to cut interesting circular patterns, or "rosettes," using an interchangeable blade borrowed from a tablesaw molding head. First, remove the

swing arm from the cutter and file or grind a slot in the arm to fit the molding cutter. Size the width of the slot carefully so the cutter is snug and can't shift during use. Drill and tap a hole in the arm, and secure the molding cutter to the arm with a short bolt.

The unit works best with the fly-cutter's center drill bit acting as a pivot. You may want to replace the center bit with a tapered rod to leave a smaller center hole. If you must work without a center pivot, clamp the workpiece firmly to the drill-press table, run the drill press at its slowest speed and be careful.

—Donald F. Kinnaman, Phoenix, Ariz.

Quick tip: To keep opened tubes of caulking or silicone adhesive from drying out, screw a large wire nut on the snout of the tube. It will keep the contents in perfect condition.

—J. Don Hazlewood, Ft. Worth, Tex.

Cutting glass circles on the drill press

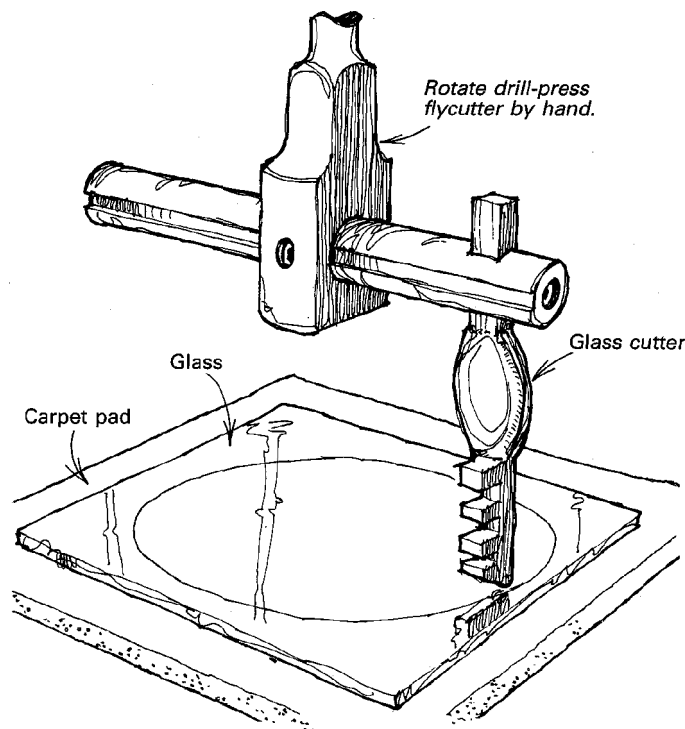

You can cut circles from glass or mirror using a drill-press flycutter and a modified glass-cutting tool. First, remove the cutting bit from your fly-cutter and replace it with a glass cutter that has its handle cut down and ground or filed to fit the hole in the fly-cutter. Adjust the device for the desired diameter circle and chuck it into the drill press. Place the glass on the drill-press table, with a thin carpet pad beneath the glass to absorb the shock. Lubricate the cutting wheel with kerosene, lower it onto the glass and lock the spindle so the cutter exerts light pressure against the glass. Then turn the drill press one revolution by hand. Caution: Don't do this under power; it would be dangerous. Besides, once around will do a better job.

Remove the glass from the drill press and make radial cuts with a glass cutter from the circle to the edge of the glass to help break the circle free.

—Bill Kilmain, Orlando, Fla.

Using kitchen knives for lathe chatterwork

Years ago, I read an article in *Fine Woodworking* (#49) about chatterwork for decorating turnings. I was fascinated, and tried the technique of applying pressure against a thin spindle with a standard lathe tool until the workpiece would bend and chatter against the tool.

As you can imagine, this technique is risky, and I ruined a lot of expensive ebony before I discovered that it makes no difference whether the work chatters against the tool or the tool chatters against the work. So, I began making special chattering tools from thin stainless-steel kitchen knives. Although these scrapers don't hold an edge long, they're flexible enough to produce beautiful chatterwork patterns. The patterns can be altered by approaching the work at different angles or by using different shape scrapers.

—Ken Hopps, Tacoma, Wash.

Quick tip: To keep lathe faceplates from binding tightly against the headstock spindle, making them difficult to remove, put a garden-hose washer between the faceplate and the spindle collar.

—Willem P. Haan, Newport News, Va.

Edging plywood with pneumatic clamps

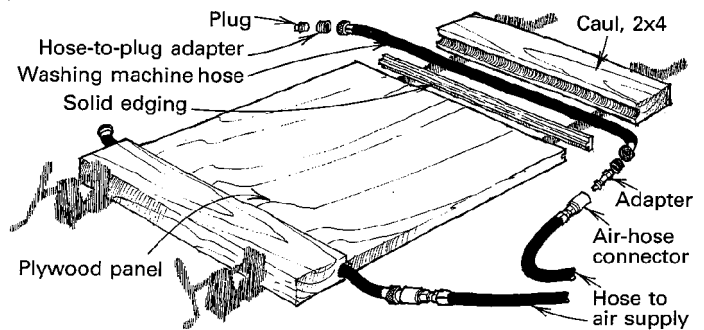

Clamping solid wood edging to plywood panels with standard bar clamps is not only a tedious and time-consuming job, but it also depletes my entire supply of clamps. So I designed the pneumatic clamping system described below which is faster, gives strong, even pressure to the wood and results in virtually invisible glue lines.

The key component of the system is a 2x4 caul, coved along one edge to fit around a stiff, high-pressure hose. Ordinary washing-machine connector hose is rated at 125 psi and works well for this. Plug one end of the hose and fit the other with a standard air hose connection.

To use the device, clamp it to the plywood being edged with a couple of bar clamps. Make sure the hose is centered over the edging being glued. Then connect the air supply (60 to 100 psi) to activate the pneumatic clamp and watch the gaps disappear as the hose expands. I made my cauls 10 ft. long so I can clamp three cabinet sides at a time. To conserve space, I plan to mount the units on the wall and stack the panels vertically.

—Jeffrey P. Gyving, Point Arena, Cal.

Threaded-dowel workbench helpers

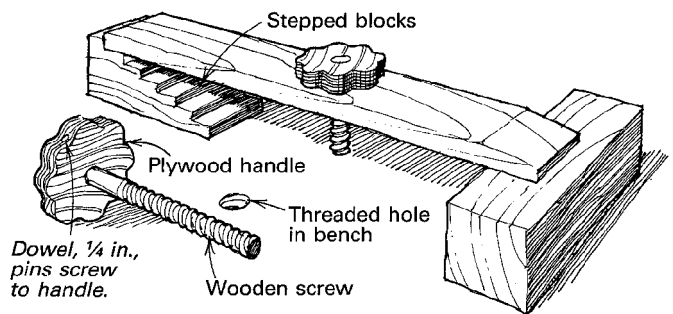

Here's a way to make that fancy wooden thread-cutting tool earn its keep. First make up a plywood handle in the shape of an oversize faucet handle. Drill and tap the handle, then insert a

length of threaded dowel and secure it in the handle with glue and pins. You now have a strong wooden screw that can be adapted to a multitude of clamping, hold-down and fastening jobs. In fact, I've found the wooden screws to be so useful that I have worked out a standardized system using holes tapped into the top of my workbench for fastening jigs and fixtures. The screws are not only strong and adaptable, but they are also ridiculously cheap.

—Thomas C. Turner, St. John's, Newfoundland, Canada

Making a shop moisture gauge

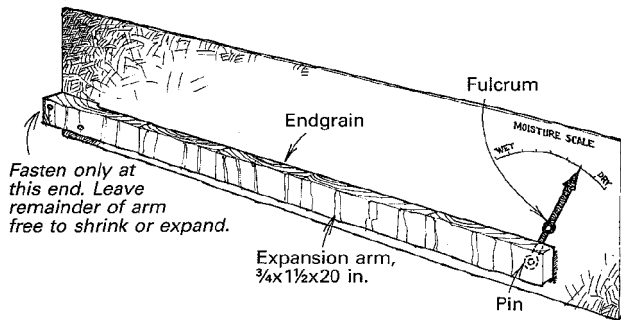

The sketch above shows a simple gauge you can make that will give you a general idea of the relative humidity in your shop. The gauge will graphically show your customers how wood moves and why you build the way you do. For the gauge to work properly, the 20-in. wooden expansion arm must be sliced off the end of a wide panel or glued up from flatsawn segments, as

shown. Movement of the gauge will be more dramatic if you pick a wood species that has a large tangential shrinkage percentage, such as beech, sugar maple or white oak. If you have access to a moisture meter, you can scale the gauge numerically.

—John Sillick, Gasport, NY.

EDITORS NOTE: For formulas on predicting wood movement, check Bruce Hoadley's book *Understanding Wood* (The Taunton Press, 63 S. Main St., Newtown, Conn. 06470; 1980).

Quick tip: To make first-class clamping pads, cover 38-in. Baltic-birch plywood with 1/8-in. cork auto gasket material. These pads won't slip around, and they are gentle on finished surfaces.

—Andrew Jacobson, Petaluma, Cal.

Taping square shoulders on turnings

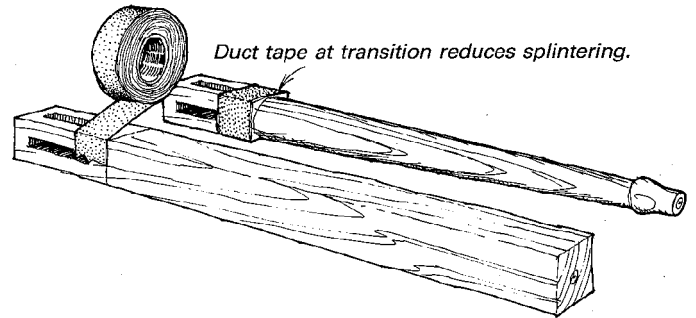

When your spindle pattern calls for a sharp transition from a square to round section, wrap the square section with duct tape so the tape edge defines the line of transition. The tape will re-

duce chip-out and provide an exact reference for making the shoulder cut. If chipping should occur, the tape holds the splinter for later regluing—no more searching through the pile for a lost splinter with less than a needle-in-a-haystack chance.

—Robert M. Vaughan, Roanoke, Va.

Quick tip: To flute a gluing dowel, hammer or press it through a box-end wrench that's $\frac{1}{32}$ in. smaller than the dowel's diameter. This compresses the flutes into the dowel, so when they're exposed to the moisture in glue, they expand and create a tighter fit than cut flutes.

—Kenneth E. Kobezak, Ringoes, N.J.

Clock cavity routing jig

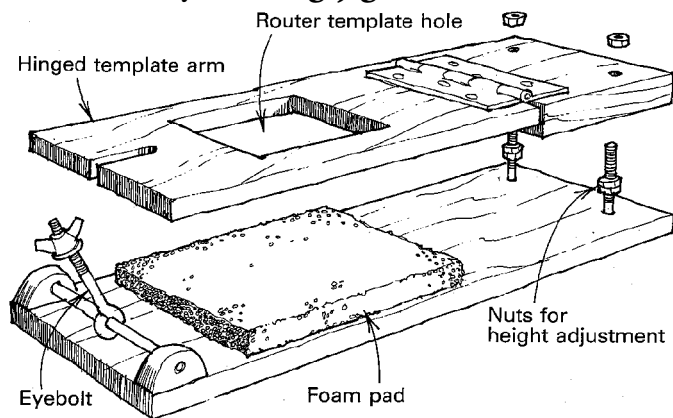

Although I devised this jig for routing a cavity for a quartz clock works, the idea could be adapted to many routing operations.

The beauty of the jig is that it combines a workpiece hold-down and a routing template into one device. It's well suited for small production runs because you can quickly pop workpieces in and out of the jig.

The jig consists of a base, a foam pad, the hinged template arm and an eye-bolt. The eye-bolt pivots on a bolt axle to fasten the template arm down over the workpiece. I attached the template arm to the base with bolts as shown in the sketch. The template arm can be set for the thickness of the workpiece by adjusting the nuts below the arm.

To use the jig, simply lay the workpiece on the foam pad, lower the template arm, lock it down with the wing nut and rout away.

—Les Stem, Denver, Colo.

Quick tip: Next time you're passing by a sporting goods store, drop in and ask to see a selection of rifle and shotgun bore-cleaning brushes. These copper-bristle, cylindrical brushes come in various diameters and can be used freehand or chucked in an electric drill. I find these brushes invaluable around the shop.

—Douglas Ruuska, Quincy, Mass.

Quick tip: To adapt an electric orbital sander for sanding gentle concave surfaces, such as those on the inside of a cedar-strip canoe, attach strips of foam weatherstripping to the pad of your sander. This extra cushion allows the sander to conform to the curves.

—Mark Blieske, Selkirk, Man., Canada

Methods of Work buys readers' tips, jigs and tricks. Send details, sketches (we'll redraw them) and photos to *Methods*, Fine Woodworking, Box 355, Newtown, Conn. 06470. We'll return only those contributions that include an SASE.

Homemade tank for heating PEG

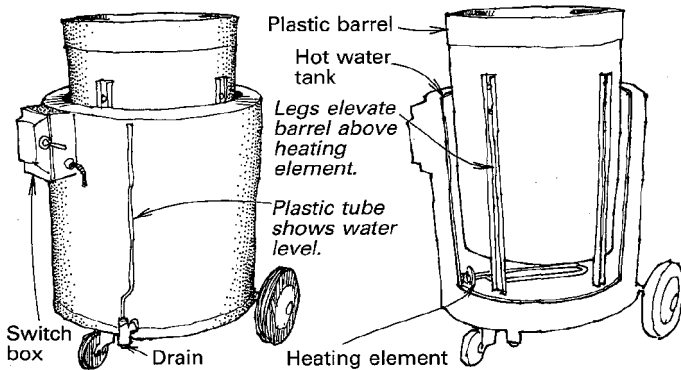

I've found soaking green wood in PEG 1000 helps reduce shrinkage of the stock I use for lathe projects. Heating the PEG shortens the time the wood must be soaked, so I built a makeshift double boiler to do the job. The main components are a salvaged electric hot water heater, a 30-gal. plastic barrel, a couple of lawn mower wheels and an old lever switch box.

The construction is simple. Remove the hot water tank from its jacket and saw both the tank and the jacket in half. Install the portion of the tank with the heating element and thermostat back into one of the half jackets and pack the space between the two cylinders with fiberglass insulation. Bolt four aluminum legs to the plastic barrel to elevate it above the heating element. Mount the switch box to the outside of the heater and wire it to the thermostat. A drain pipe with a T-shape pipe fitting is screwed into the bottom of the tank. The bottom of the T is plugged and the top is connected to a clear plastic tube that acts as a water-level sight glass.

Now, fill the hot water tank with water and the plastic barrel with PEG 1000. Set the thermostat to keep the PEG solution at the manufacturer's recommended temperature.

—Charles Manning, Port Townsend, Wash.

Pivoting router mortising fixture

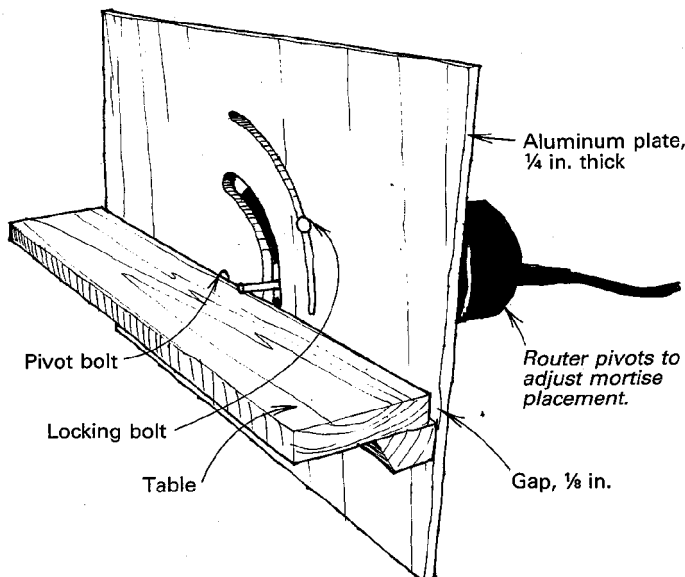

Because I needed to cut more than 400 mortises in a short period of time, I built this pivoting router fixture. With it, I can cut two mortises in about one minute, including the layout time, so the four hours I spent building the jig were quickly repaid.

The router is attached to an aluminum plate with a single bolt so it will pivot to adjust for the position of the mortise in the stock. The plate has two concentric slots centered on the pivot bolt: one for the mortising bit and one for a locking bolt and wing nut. A cleat to support the table is screwed to the plate and a hardwood table is glued and screwed to the cleat with a 1/8-in. gap left between the table and plate for chip and dust clearance. My aluminum plate is 3/4x12x20. I recommend 6061 aluminum with a hardness of at least T3. You can mill the curved slots in the plate by building a special pivoting fixture and using a milling cutter in the drill press. Or, if you're patient and careful, you can rout the slots with a router and double-flute carbide bits with a trammel or circle-cutting fixture. Take several light cuts. After the plate is completed, install the fence and attach your router.

To use the mortising jig, bolt or clamp it to the edge of a stout table or workbench. Adjust the router for mortise placement and depth of cut. Then, start the router and push the stock from left to right past the bit. Plunge the stock onto the bit for stopped mortises. Use stop blocks for repetitive cuts or draw layout lines on your stock to show you where to start and stop your mortise in relation to the bit's slot. Don't try to mortise pieces that are too narrow or are shorter than about 12 in. In addition, use the same caution you would with any router-table operation.

—James E. Gier, Pine, Ariz.

Super rasp

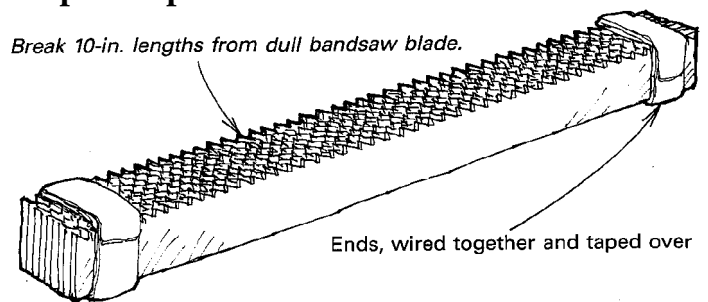

My pack-rat instincts paid off one day when I needed a heavy-duty rasp for a sculpture. Retrieving a broken 1-in.-wide bandsaw blade from the junk pile, I snapped off 10-in. lengths in the vise until I had a 1-in.-thick stack. I bound the ends together with wire and taped over the wire with duct tape. In about 10 minutes, I made the fastest-cutting, easiest-cleaning rasp I've ever had my hands on.

With a little more experimentation, I found that wider blades worked better and staggered teeth made a smoother cut. Blades can be added or subtracted to make rasps of specific widths. To release chips, flex the blades in the middle.

If you make a super rasp, please be careful. This monster eats knuckles with the same appetite that it eats wood.

—Greg Connell, Lake Elsinore, Cal.

Quick tip: Cut a length of bicycle inner tube an inch or two long and stretch it over the middle part of your drill chuck. The rubber will make it much easier to spin the chuck open and closed by hand.

—Bill Webster, Chillicothe, Ill.

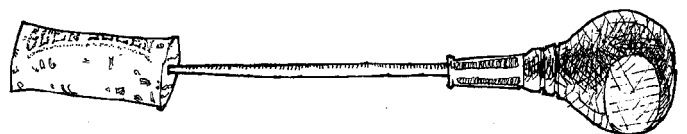

Quick tip: Use wine bottle corks to cover the tips of scratch awls, compass points and the like. The corks keep the points of your tools sharp, and they protect your fingers when you're

rummaging through the toolbox.

—Tony Konovaloff, Tahoe Paradise, Cal.

Adapting an in-place knife grinder

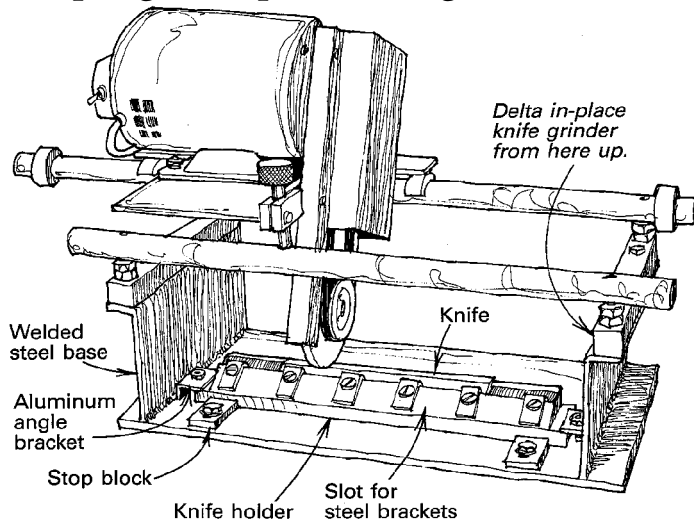

Past issues of *FEW* have presented a number of methods for grinding jointer knives. I've never been satisfied with the in-place knife-grinding attachment from my Rockwell 13-in. planer, so I designed a steel base to adapt the in-place grinder for use off of the planer. This fixture provides excellent and professional results. I can also use it to hone my planer knives and grind my jointer knives.

The fixture consists of the knife grinder, a welded steel base and

an aluminum knife holder machined to hold the knives at a 36° grinding angle. I bolted my equipment to the steel base by drilling and tapping holes; this is the same way it's attached to the planer. The knife holder is clamped to the bottom plate of the base with aluminum angle brackets at each end. With steel brackets, clamp the knife to be sharpened to the knife holder. Tighten it in place with bolts threaded into holes drilled and tapped in the angled face of the holder. Adjustable aluminum stop blocks align the knife holder so the knife is centered under the grinding wheel and is parallel to the wheel's travel. The grinder's guide bars are then adjusted so the grinding wheel travels parallel to the knife holder. After making these adjustments, push the stop blocks against the knife holder and bolt them in place. This allows the knife holder to be removed and replaced in the same position for grinding the remaining knives.

—Earl M Wintermoyer, Niceville, Fla.

Blocks for squaring a carcass

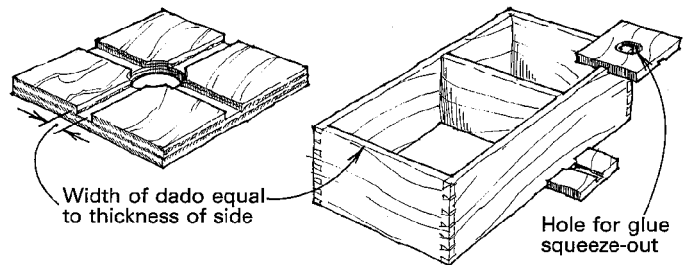

While gluing up and clamping a cabinet case without a back, it was difficult to keep the case square. So, I made the alignment

blocks pictured on the previous page by cross-dadoing an 8-in. square of $\frac{3}{4}$ -in. plywood. The width of the dado is equal to the thickness of the case material. I drilled the center of the block to prevent glue squeeze-out from permanently attaching the blocks to the case.
—Gaylord R. Livingston, Chazy, N.Y.

Quick tip: To prevent a skin from forming on oil-base paints, carefully pour a little pool of mineral spirits or turpentine on top of the paint. Let the paint can sit for a half hour or so with the lid slightly ajar, and then tap the lid shut. The fumes from the solvent will displace the air in the can, thus preventing oxidation and paint skinning.

—C. Peter Duncan, Walnut Creek, Cal.

Dowel-center marker

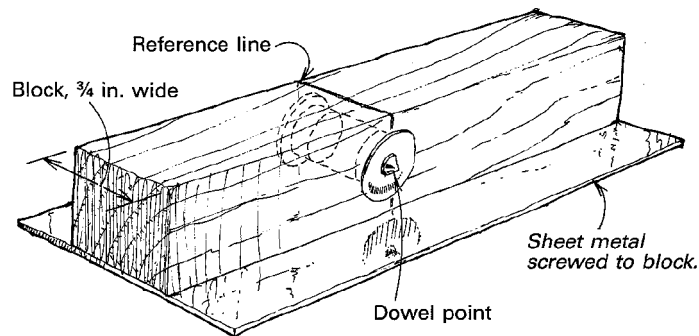

If you use a lot of doweled edge joints, this dowel-center marker will speed up the layout process by marking the mating holes

simultaneously. It's made from two steel dowel points, a hardwood block and a small piece of sheet metal. First, countersink for the shoulder of the steel points on opposite sides of the block, and then drill the through hole. If you have access to a drill press, use it to ensure accuracy. Glue the points in place with epoxy, and attach the sheet metal fence with a couple of small flat-head screws.

Lay the two boards, aligned just as they're to be glued, on a clean workbench. With a framing square, draw a line across the two boards where a dowel will be needed. Now, place the dowel-center marker between the boards, matching the reference line on the marker block with the lines drawn on the boards. Tap the boards together, against the points, to mark both boards at the same time.

With long material, I mark and drill the first mating holes on one end and join the pieces dry with a dowel $\frac{3}{4}$ in. longer than I intend to use. This keeps the boards in registration and holds them far enough apart so I can move the marker to any point along the length of the boards and make accurate marks.

—Harry E. Hunter, Oakville, Conn.

Quick tip: Here's a quick method for securing hardwood handles to socket chisels when the taper is undersize. Spread some steel wool into a thin, even blanket over the socket and drive the handle home. Adjust the thickness of the blanket until you get a good fit. Then, trim off the excess steel wool with a utility knife.

—Edward Tyderkie, Man., Canada

Methods of Work buys readers' tips, jigs and tricks. Send details, sketches (we'll redraw them) and photos to Methods, Fine Woodworking, Box 355, Newtown, Conn. 06470. We'll return only those contributions that include an SASE.

Wing nut replacement

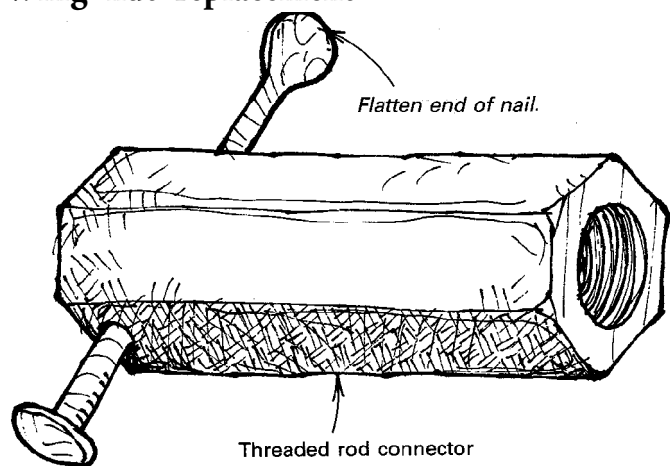

Since I'm not a super-macho type, I don't particularly welcome the pain in my thumb that comes from really torquing down a wing nut. So whenever possible, I replace them with the rod connector tighteners described below. In addition to relieving my thumb, the gadgets can be tightened with more force and go in smaller places than regular wing nuts.

To make the tightener, go to the local hardware store and buy a threaded-rod connector that's the same size as the wing nut you need. Drill a hole through one end of the connector and slip a nail through the hole. Flatten the pointed end on an anvil and grind the flattened end smooth. The device will make tightening and untightening a breeze.

—Gordon C. Su, Sandy, Utah

Quick tip: Carbon tracing paper leaves hard-to-remove blue lines, but dressmaker's tracing paper leaves lines that are easily removed with a damp cloth. The paper is available in many colors, including white and orange, allowing tracings to stand out on a variety of wood surfaces. It can be found in fabric and sewing shops.

—Stephen Finch, Little Grove, Australia

Jig for routing sliding dovetails

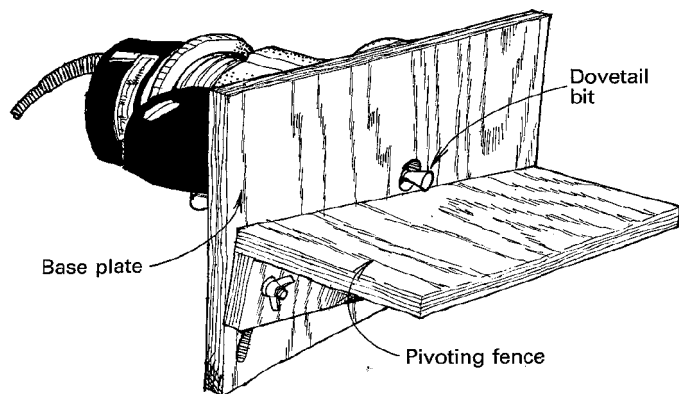

After reading Mac Campbell's article on sliding dovetails (*FWW* #62, p. 80), I was compelled to use the joint on a project. The jig for cutting the pin that Campbell describes is attached to the edge of an existing tabletop. I modified the jig so a wood baseplate mounted on the router replaces Campbell's stationary table. With the whole fixture attached to the router, I can move the bit across the wood rather than having to move the wood across the bit. With long pieces, this can be a big advantage in a small shop.

To cut the dovetail slot, I remove the fence entirely and slide

the baseplate against an auxiliary fence clamped to the workpiece. Then, I re-attach the fence and adjust it to cut the correct size dovetail to fit the slot. I mark where the fence is set so I can repeat the setting.

—Larry Naumann, St. Louis, Mo.

Quick tip: Hand-held wire brushes will dull with use as the wire ends become rounded. Run the brush lightly back and forth across the face of a grinding wheel to get it working as good as new.

—Dean Feight, Altoona, Ia.

Storing router bits

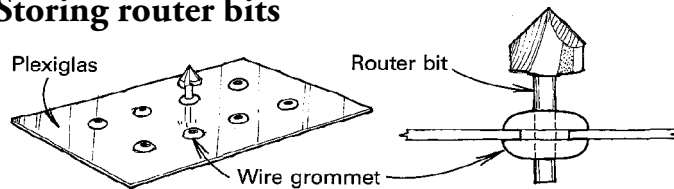

This simple router bit storage rack will hold your bits securely and keep them from falling out or rattling against each other. The rack is made from a sheet of 1/8-in.-thick Plexiglas and wire grommets. Wire grommets are rubber, donut-like rings available at auto parts stores in a variety of sizes; take a router bit with you so you can buy the size that fits just right.

To make the rack, select a drill bit the same size as the core diameter of the grommet. Drill holes in the Plexiglas at 1-in. to 2-in. intervals and install a grommet in each hole. Installation will be easier if you lubricate the skirt of the grommet with a drop of oil.

—David McCampbell, Salmon, Ida.

Spreading contact cement

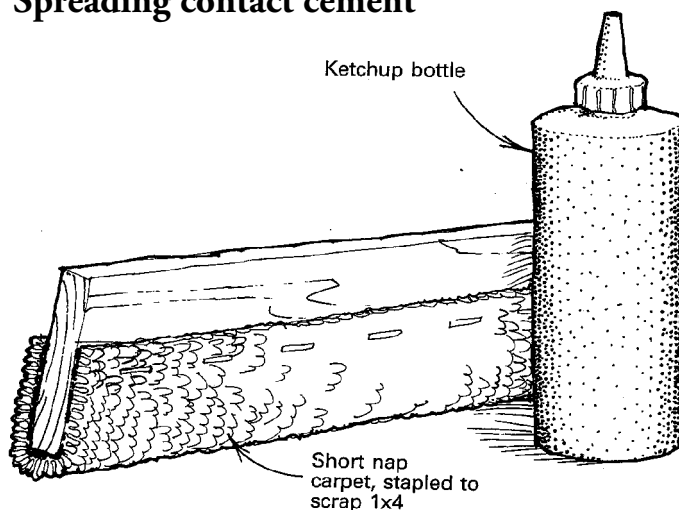

As part of my general contracting business, we've built Formica-covered cabinets for years. But, applying the contact cement was an ongoing problem. We found that cleaning a spray gun took too much time and using rollers or paint brushes was just too messy. The simple, neat system we finally developed requires two items: a spreader made from carpet scraps and a plastic ketchup bottle to dispense the cement. Make the spreader by stapling a piece of short-nap carpeting to a 6-in.-long 1x4 scrap. Because the spreader takes only a minute to make and is free, we just throw it away when the job is done.

We purchase ketchup bottles by the dozens from a restaurant supply house. The big ones are about 8 in. tall and cost 20 cents a piece. A bottle may last several weeks before it begins to gum up, and once it does, we throw it away and start with a new one.

To apply the cement, squeeze out a zigzag bead of cement

Methods of Work (continued)

onto the counter and the Formica. Then, spread the cement over both surfaces with the carpet-covered block. Right-handed people should hold the squeeze bottle in their left hand, the spreader in their right and work from right to left. With a little practice, you'll be able to keep the proper amount of cement in front of the spreader, which will make the operation quick and neat.

—Tim Hanson, Indianapolis, Ind.

Quick tip: Troubled by guilt from dumping used mineral spirits in a hole in my yard, I began pouring it into a clear plastic container. I noticed the sediment eventually settled out and the liquid on top was clear. I pour this off and reuse it, saving both money and guilt. — Dr. Alan J. Pollack, Woodland Hills, Cal.

Using headlamps

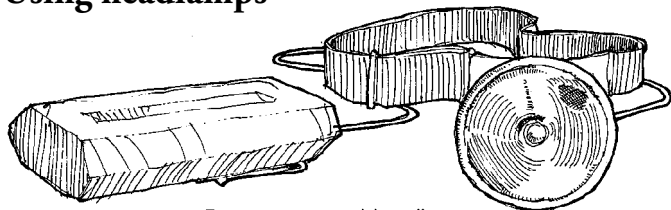

Battery-powered headlamp

We often don't realize how poor our shop lighting is because of our eyes' ability to make do. And even in a well-lit shop, when doing really close work, you'll find yourself working in your own shadow more often than not. The bright, focused light from a battery-powered headlamp is quite helpful in a variety of shop situations—taking measurements, sharpening blades and making adjustments inside a machine to name a few. A good source for

headlamps is Recreational Equipment Inc., Box 88125, Seattle, Wash. 98188.

—Rick Kjarval, Chicago, Ill.

Quick tip: To clean paintbrushes, cut a cross in a plastic coffee can lid, push the brush handle up through the cut and snap the brush/lid combination back onto the can. The lid will suspend the brush in the thinner while keeping the bristles away from the bottom of the can. And you can wiggle and slosh the brush without splashing paint thinner all over yourself.

—Larry A. Huff, Anamosa, Ia.

Marking ruler



For marking up long pieces of lumber or sheets of plywood, I use an 8-ft. length of $\frac{3}{4}$ -in. by $\frac{3}{4}$ -in. aluminum angle, which is available at most lumberyards. I attach self-stick tape rules (available from Woodcraft Supply, Box 4000, Woburn, Mass. 01888) on the two outer edges. The combination of the aluminum's thickness and the right-angle shape keep the rule straight and make it ideal for marking and layout.

—Bill Endress, Orlando, Fla.

Weather strip for drawer rails

I've had to repair the drawer sides on several old chests due to wear between the side and the drawer rail. It's not a difficult job, but it's unpleasant nonetheless. Through my vocation, which is energy conservation, I've recently encountered a product that promises to eliminate drawer wear, and thus aid me in my avo-

cation, which is woodworking.

The material generically called V-Seal is a very thin PVC plastic. It comes on 1-in.-wide rolls with an adhesive strip that is slippery and long wearing. It is folded and stuck on a door frame as a weather strip. In its woodworking application, I stick the material, left unfolded, to the top of the drawer rail. It reduces friction dramatically and will, I believe, eliminate further wear to the drawer. The material is available at a reasonable cost at most hardware stores.

—Edward Minch, Wilmington, Del.

Shop-built drawer clamps

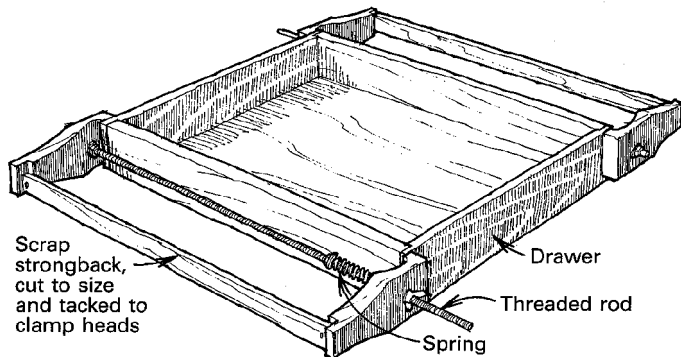

You can make up these drawer clamps quickly in any size needed. Just bandsaw the clamp heads from scraps of hardwood from around the shop and mount them on threaded rods. Cut a strongback to whatever length you need for a given job and tack it to the notch in the clamp heads. When clamping several of the

same size drawers, a spring will help keep the clamp heads set at the right distance as the clamps are removed and replaced.

—Earl J. Beck, Oak View, Cal.

Vacuum hose connectors from plastic cups

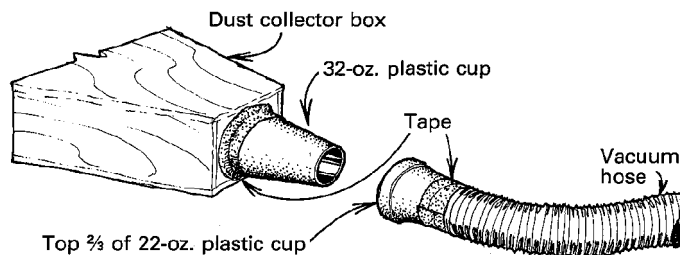

I move my portable dust collector around the shop as needed. This system requires a quick way to connect the 3-in. hose to various tools. I discovered that refillable plastic soft drink cups, the kind sold at convenience stores, make an excellent connection system that's quick, tight, long lasting and very inexpensive.

First, I saw a 4-in.-dia. hole in the machine's collector box and, from the inside, I insert a 32-oz. cup, bottom first, all the way up to its reinforced lip. I tape around the cup on the outside of the collector box to hold it in place and then cut out the cup's bottom. I make the mating connector by cutting off the top two-thirds of a 22-oz. cup and taping it to the dust collector hose. Experiment with cup sizes to find a tight-fitting combination for your system.

To fasten the hose to the machine, push the cups together—they will stay in place. To remove, just pull with a twist. If the connector should eventually crack, treat yourself to another

soft drink. It'll take longer to finish the drink than it will to replace the fitting. —*Ronald E. Miller, Macksville, Kan.*

Quick tip: Slipping a pair of discarded panty hose over the paper filter element on your shop vacuum will keep the filter from clogging without reducing the air flow. Because sawdust just shakes off the nylon, cleaning the filter isn't so messy.

—*Roger Irwin, Palm Bay, Fla.*

Collet and draw bolt lathe chuck

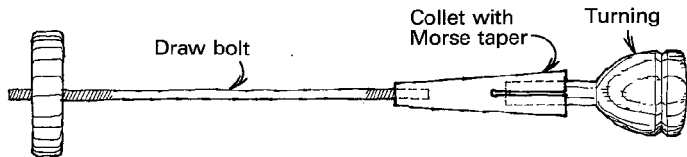

A simple Morse taper $\frac{1}{2}$ -in. collet chuck used with a draw bolt is an effective alternative to a heavy, expensive 3-jaw Jacobs chuck for turning small pieces. When the draw bolt is tightened, the collet's jaws securely grip the work. Morse taper collets are available from machine tool suppliers or Manhattan Supply Co., 151 Sunnyside Blvd., Plainview, N.Y. 11803.

—*Eric Schramm, Los Gatos, Cal.*

Quick tip: I always had trouble with the small squares of plywood I used as clamp pads falling off before I could tighten the clamps. I solved this problem by sticking a small piece of pressure-sensitive magnetic tape to one side of the plywood. Rolls of the magnetic tape are available from Brookstone Co., 127 Vose Farm Ed., Peterborough, N.H. 03458. —*Ralph W. Brome, Annapolis, Md.*

Quick long-reach clamp

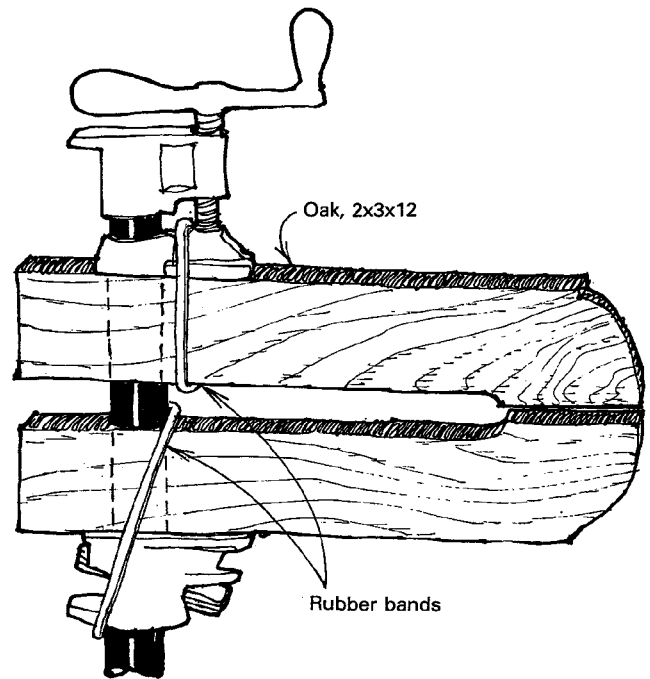

Here's a long-reach clamp that can be made in minutes from an ordinary pipe clamp and scrapwood. The jaws are bandsawn

from two oak 2x3s that are about 12 in. long. Drill a hole the same diameter as the pipe, through one end of each jaw, and then slip the jaws onto the pipe between the regular clamp heads. Finally, install rubber bands, as shown in the drawing on the previous page, to keep the jaws in place.

—*Dwight Christiansen, Newell, Ia.*

Quick tip: When painting or varnishing all sides of a box or other small project, you can use three or four thumbtacks, with the points up, to elevate it above the table, thus preventing it from sticking.

—*Dustin Davis, Frostburg, Md.*

Plastic bag paint pot liners

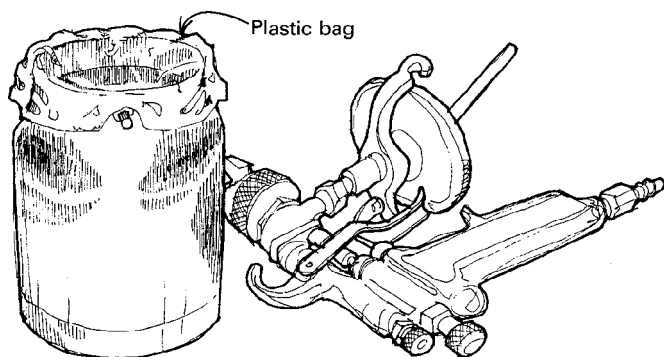

I keep a supply of plain one-gallon plastic food storage bags (without a zipper-like closure) to line the quart pot of my spray gun. This trick only works in pots with lever releases, not those

that screw to the gun. I generally use two bags at a time, in case one should leak. The bags simplify waste disposal and minimize the amount of expensive solvent needed to clean the pot. I've never had any problem with solvents dissolving the bags.

If you're going to be spraying the leftover material soon, it may be sealed right in the bag with twist ties and stored in an empty quart paint can. However, if you leave paint sealed inside the bag for long, the material that dries on the inside of the bag may cause problems when spraying.

—*Bruce De Benedictis, El Cerrito, Cal.*

Quick tip: To avoid chipping the veneer when sawing cross-grain dados in plywood, make two passes. Cut through only the face veneer on the first cut, and then make a second pass to full depth.

—*John Kriegsbauser, Kansas City, Mo.*

Matching a box to its lid

When I build small boxes, I construct the box body and the lid together as a solid unit and slice the top away from the box later. This ensures that the lid matches the size and grain of the body perfectly. One word of caution—it's risky to saw the lid right off the box. Instead, set your tablesaw blade's height at $\frac{1}{32}$ in. less than the thickness of the side of the box before sawing all four sides. This approach will leave the lid attached with a thin web of wood, which can be cut with a razor knife before pieces are sanded and finished.

—*Curtis W. Mead, Troy, N.H.*

Methods of Work buys readers' tips, jigs and tricks. Send details, sketches (we'll redraw them) and photos to *Methods*, Fine Woodworking, Box 355, Newtown, Conn. 06470. We'll return only those contributions that include an SASE.

Dovetailing with a laminate trimmer

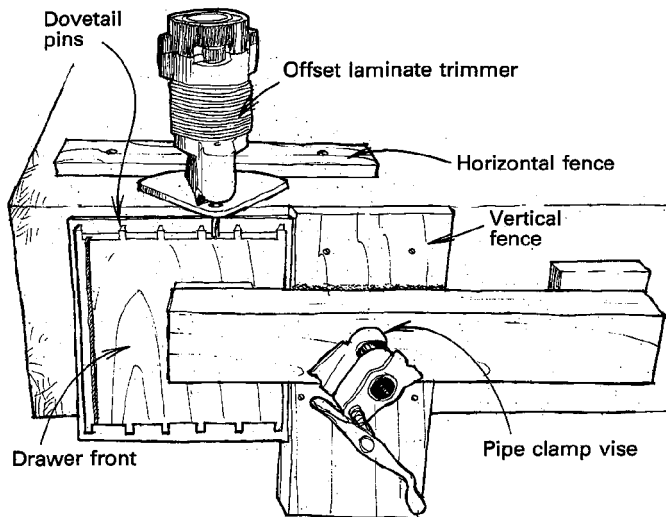

The most time-consuming part of dovetailing drawers is the tedious tap-tap-tapping with mallet and chisel to cut the half-blind pins in the drawer fronts. So, when I was faced with making eight mahogany drawers with a 1/4-in. overlay on the fronts, I decided to cut these pins with an offset laminate trimmer that I'd recently acquired. The method I devised takes advantage of the offset trimmer's unique features: It provides excellent visibility of the bit, it is small and lightweight and it has an offset center of gravity. The resulting pins are speedily and easily cut without looking as if they were mass-produced with a jig.

First, I laid out the tails on the drawer sides using the two dovetail marking tools described in *FWW* #53 on p. 51, and then bandsawed them out. Because the backs were joined with simple through dovetails, I marked the pins from the tails and bandsawed them.

After marking the pin locations for the half-blind dovetails on the drawer fronts, I clamped one of the fronts to the side of my worktable using a special setup and pipe clamp vise, as shown in the above drawing. Two fences are key to the setup. The vertical fence is fastened to the side of the workbench and registers the drawer front to ensure that it's perfectly square with the top of the table. The horizontal fence is screwed to the tabletop and acts as a guide to run the base of the router against. This fence is set parallel with the edge of the table and just far enough away from the edge to leave the proper lip on the drawer front. To cut the pins I chucked a 3/16-in. straight router bit in the trimmer and adjusted the drawer front in the vise so that the depth of cut was right to the line representing the thickness of the side piece. I turned on the trimmer and carefully wasted the areas between the pins by routing right up to the scribed lines. Very little trimming with a chisel was necessary to clean up the joint when the routing was complete.

The offset trimmer is particularly well suited for this kind of work because its center of gravity is over the table, not over the bit. For safety's sake, be sure to use a face shield and goggles to keep the blizzard of little wood flakes out of your eyes.

—John E. Janbaz, Amarillo, Tex.

Quick tip: Here are two ways to cushion metal vise jaws. Drafting table cover material, available at art supply stores, can be fastened to the jaws with spray adhesive or rubber cement. Or, you can cut a pad from the material used for removable magnetic signs for car doors. The magnetic material will stick to the metal jaws and provide sufficient cushioning to protect your work.

—Jay Wallace, Ashland, Ore.

Hanging a mantle with bed rail fasteners

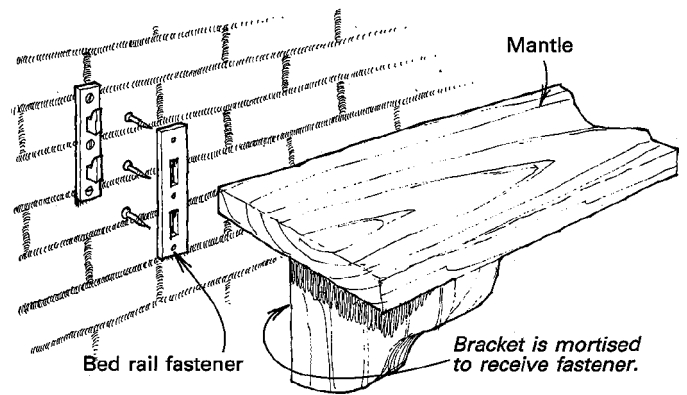

Fastening a wooden mantle to a masonry fireplace is a knotty problem that's usually solved by anchoring a baseboard to the masonry and building the mantle in place. A better solution is to build the entire mantle in your shop, and then hang it on the fireplace with high-quality bed rail fasteners. The heavy steel fasteners, commonly available from mail-order hardware stores, are strong enough for even the heaviest mantle and allow you to remove the mantle later if needed. Screw the male component to the masonry using masonry anchors, and mortise the mating portion to the mantle bracket deep enough so the mantle can pull up flush to the brick. This technique can also be adapted for fastening heavy bookcase or stereo units to walls. Just make sure you screw the male component to a stud.

—Joe Collier, Mulberry, Tenn.

Making bandsaw table clamping easier

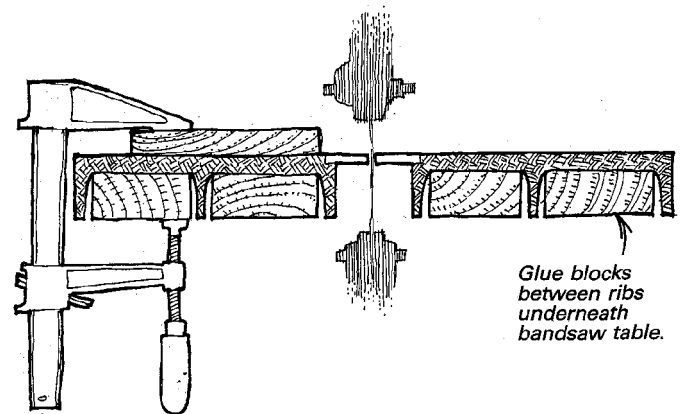

A corollary of Murphy's law says that whenever you want to clamp a fixture to your bandsaw or drill-press table, a rib underneath will be in the way. When I finally got tired of fighting Murphy on this one, I cut blocks of wood and epoxied them into the odd-shape cavities between the ribs underneath the table. The blocks, which are slightly thicker than the depth of the cavities, let me put clamps wherever I want without worrying if I'll have a flat, solid perch.

—Marc Vais, Montreal, Que., Canada

Keeping paint from skinning

Over the years, I've read some complicated methods for keeping a partly filled can of paint or varnish in usable condition. This method is simple and I know it works because I've used it for 30 years.

Start with a sheet of good-quality magazine paper. I use an old issue of *National Geographic*. Put the paint can lid on the paper

and trace around it with a pencil. If you cut $\frac{1}{16}$ in. outside the pencil line, your paper circle will be just smaller than the inside of the can. Make sure the paper fits inside the can; if it is even a little too large, the trick won't work. Bend the paper so it can be lowered into the can, and then release it. The paper should open up flat on top of the liquid.

When you want to use the material, simply break the seal around the paper with a knife or screwdriver, remove the paper and discard it. It's a good idea to mark the paint level on the outside of the can before resealing the lid so you won't have to shake the can and disturb the paper seal to find out how much paint you have.

—Tim Hanson, Indianapolis, Ind.

Stacker handles for shelf finishing

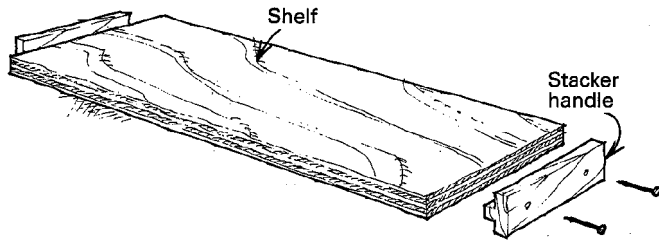

I cut 8-in.-long T-shape stacker handles from scrap and nail one to each end of shelves before applying finish. The handles let me finish both sides of the shelf at once, and then stack the shelves while they dry. They also make it easy to wipe off excess stain or oil without adding fingerprints to the finish.

—R. Charles Boelkins, Conyers, Ga.

Router jig for flush shelf edging

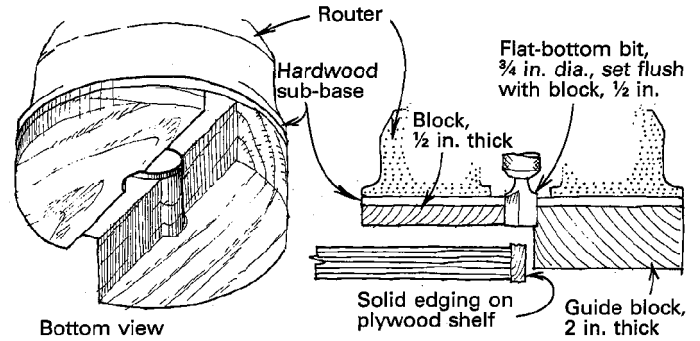

Here is a router jig for trimming edge moldings flush with a flat surface. I have used this jig for trimming the edging on tables and countertops, but its most useful role is trimming solid-wood edging on plywood to be used as adjustable shelves for bookcases.

The jig consists of two wood blocks screwed to a hardwood router sub-base. A $\frac{3}{4}$ -in.-dia. flat-bottom router bit is set to cut flush with the $\frac{1}{2}$ -in.-thick block that rides on the surface of the plywood shelf. A 2-in.-thick block acts as a guide to run along the front of the shelf edging. Run the router over each face of the shelf to trim the edging flush with the plywood surface.

To save time when edging the shelves, I rip a $\frac{7}{8}$ -in.-wide, solid-wood strip that's about $\frac{1}{8}$ in. thicker than the plywood. Then, I glue up a sandwich with the solid-wood strip between two of the shelves. You don't have to be very precise in aligning the edging and plywood because the extra $\frac{1}{8}$ -in. thickness will be

trimmed off later. When the glue has cured, rip through the center of the edging stock on the tablesaw to separate the shelves, and then joint the face of the edging strips. To complete the shelves, attach the edging jig to the router and set the bit for a flush cut.
—Lynn Mickelson, Seattle, Wash.

Quick tip: The best pair of safety glasses I've seen are made for welders and are available in welding supply houses. They have clear tempered glass lenses, side screens and metal frames with ear hooks to prevent them from sliding off your nose when you bend over.
—Sam Savage, Needham, Mass.

Stop blocks for mitered corners

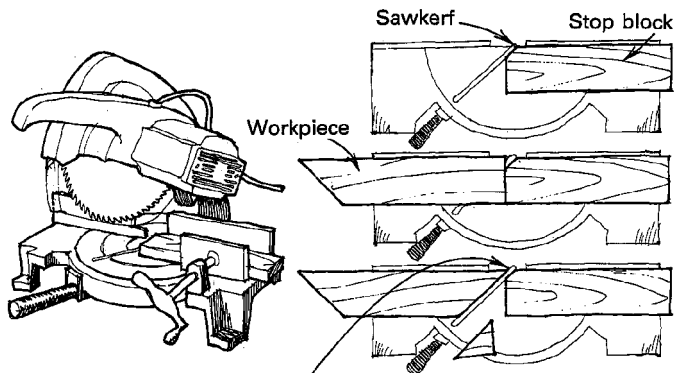

Left side of kerf bisects corner of workpiece.

One of the reasons I purchased a motorized miter box saw was so I could cut 45° miters for picture frames. Lacking an

extension table or fence to which I could clamp a stop block, I was marking the piece and then cutting it to length by nipping at it with miter cuts. This trial-and-error method was very tedious and unreliable. Then, I discovered that if I first cut the pieces to length with square cuts, I could clamp a stop block on the waste side of the blade to perfectly position the stock for the miter cut.

The stop block is clamped so the left side of the blade's kerf bisects the square corner of the molding (shown below left). It usually takes a few trial cuts to locate the stop block, but if you don't go all the way through with these cuts, you can manage the setup with a single test piece. Then, after cutting all your workpieces to length, you simply bump their square ends against the block, hold tight and cut.
—Allan Walton, Seattle, Wash.

Quick tip: If you must interrupt your work while using quick-setting epoxy or other two-part glues, you can often save the batch of glue by placing it in a freezer. This doesn't always work, but it's worth a try.

—Ron Fink, Burnaby, B.C., Canada

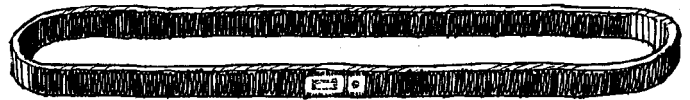

Motorcycle rim strip

Quick tip: Large rubber rings, called motorcycle rim strips, are handy for clamping, wrapping bundles of wood and other uses around the shop. The rim strips are available in a variety of

sizes from J.C. Whitney, Box 8410, Chicago, Ill. 60680, for less than 50 cents each.

—Rick Kjarval, Chicago, Ill.

Mitered box jig

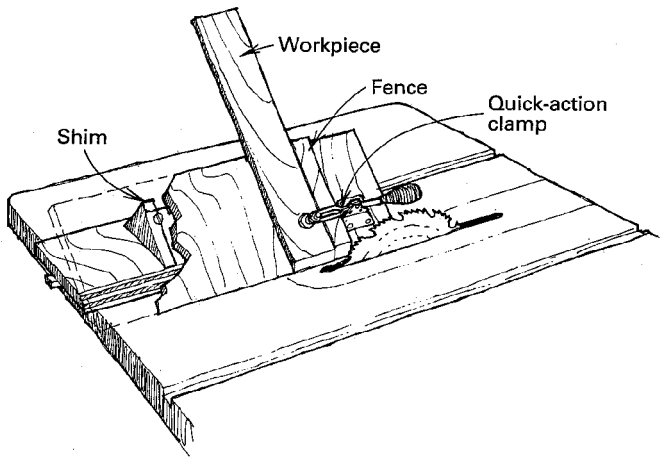

When making small boxes with mitered corners, I find it very time-consuming to set the tablesaw to the required dead-accurate 45° cut. Hence, I made this little jig, and with it, I can cut the miters quickly, accurately and, most of all, safely—and with the blade set at 90°.

Make the base and slanted platform from seven-ply birch plywood. Cut the two inside supports as close as possible to 45° on the tablesaw. Fasten these two supports to the base with screws and glue. Then, attach the slanted platform to the supports, but

do not glue them and use only one screw. This will allow you to shim the slanted platform to fine-tune the angle later if needed. Screw a vertical fence onto the slanted platform, square to the platform's long edge, and a guide rail to the bottom of the base to run in the saw's miter gauge slot. Finish the jig with two or three coats of polyurethane to repel moisture. Finally, screw an adjustable, quick-action clamp to the jig to hold the material firmly during the cut. This clamp is essential. For safety's sake, do not attempt to use the jig without it.

To calibrate the jig, make a trial cut with scrap lumber and check it with a 45° square. Adjust the platform with shims between the supports and the slanted platform until the cut is exact. For even finer tuning, cut four identical pieces and miter all their ends. Assemble the four pieces to ensure all four corners are dead on. If not, shim the platform again, this time with thin paper. Tighten both screws the same amount each time.

Now you're ready to make boxes. I use masking tape to roll the box together, both for trying the fit and also for holding the corners while the glue sets. —Ken Wall, Sand Springs, Okla.

Quick tip: Sawcuts, both with hand tools and power tools, can leave splintered, chipped and fuzzy edges. For clean, sharp cuts, try this old carpenters' trick: Carefully score the good side of the line with a utility knife and a straightedge before sawing. The score line has to be just deep enough to sever the wood's surface fibers. —Michael Q. Anderson, Albuquerque, N.M.

Another way to spread contact cement

I have limited occasion to lay plastic laminate, so I don't keep the necessary tools around. When I need to spread a little adhesive, I use a serrated spreader cut from the side of a milk carton

or other readily available source of fairly stiff plastic. I cut the serrated edge with my wife's pinking shears. If this particular use of pinking shears is questioned at your house, feel free to point out that I've been doing it for 15 years with no ill effects.

—John Stockard, Milledgeville, Ga.

Quick tip: A full-face shield may provide excellent protection while working at the lathe, but it quickly attracts dust while sanding parts. To reduce this problem, wipe the face shield with an anti-static cloth, like the kind that is available from photo supply stores.

—Mac Campbell, Harvey Station, N.B., Canada

Shop-built folding attic stairs

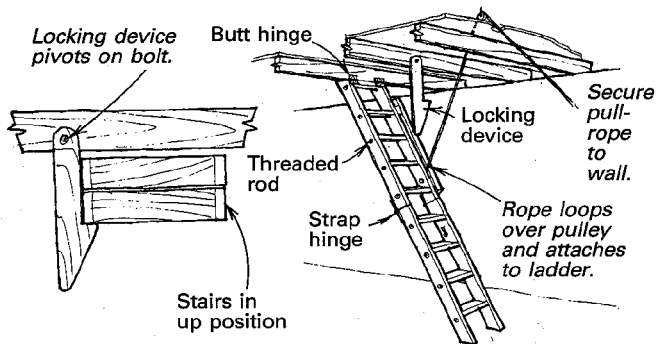

When I needed more space in my shop, I decided to use the attic. I couldn't afford to give up any floor space, so permanent stairs were out. And, since I didn't want to cut the ceiling joists, a

requirement for manufactured disappearing stairs, I decided to build by own version of disappearing stairs.

The basic layout of the stairs is shown in the sketch. I cut the stair runners and the treads from 2x4 stock and ran a length of 3/8-in. threaded rod under each tread to hold the stair units together and strengthen the treads. The two stair units are joined with strap hinges. The top unit is attached to a ceiling joist with standard door butt hinges.

By unhooking the rope and moving the locking device, shown in the drawing, over to one side, I can lower the ladder and extend it to the floor. Then, by pulling on the rope, I can raise the ladder and fold it up. As it approaches the ceiling, the ladder nudges the locking device over until it swings back and locks the stairs in place. Then, the rope is secured to a hook on the wall to ensure that the stairs can't come down accidentally. Because the locking device is 7 ft. above the floor, you don't have to worry about small children gaining access to the attic.

—Charles Topp, Charlotte, N.C.

Quick tip: Here's a neat way to drive small finish nails into tight places. Push the nail through the corner of a piece of corrugated cardboard, about 1 in. wide by 3 in. long. Position the nail with the cardboard and you can hammer away without danger of marring the work or mashing your fingers. Before you drive the nail home, tug the cardboard loose.

—Jim Vast, Williamsville, N.Y.

Methods of Work buys readers' tips, jigs and tricks. Send details, sketches (we'll redraw them) and photos to Methods, Fine Woodworking, Box 5506, Newtown, Conn. 06470-5506. We'll return only those contributions that include an SASE.

Calculating the radius of an arc

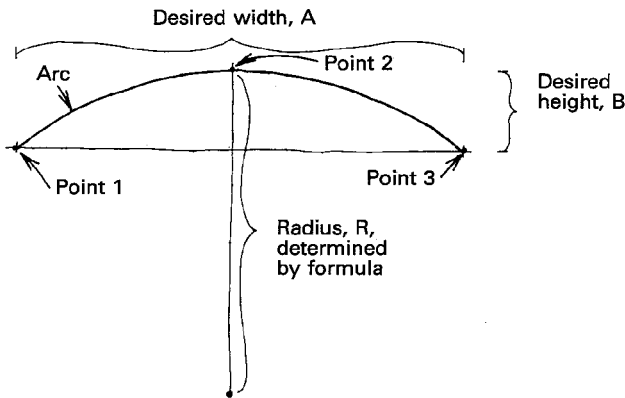

Quite often, when designing a curved cabinet or tabletop, you need to determine the radius of an arc that will give you a specific amount of convexity (height of arc) and also fit within a specified width. Here's a formula for calculating the radius of an arc that must pass through three predetermined points. With it you can find the radius (R) from the desired width (A) and height (B) as defined by the three points, shown above. The formula is:

$$\frac{\left(\frac{A}{2}\right)^2 + B^2}{2B} = R$$

For example, to find the radius of an arc that is 12 in. wide and 2 in. high, let A = 12 and B = 2. Then:

$$R = \frac{\left(\frac{12}{2}\right)^2 + 2^2}{2 \times 2}$$

$$R = \frac{(36 + 4)}{4}$$

Finally, R = 10. The arc's radius is 10 in.

—Barrie Graham, Arundel, Que., Canada

Squaring cabinets during glue-up

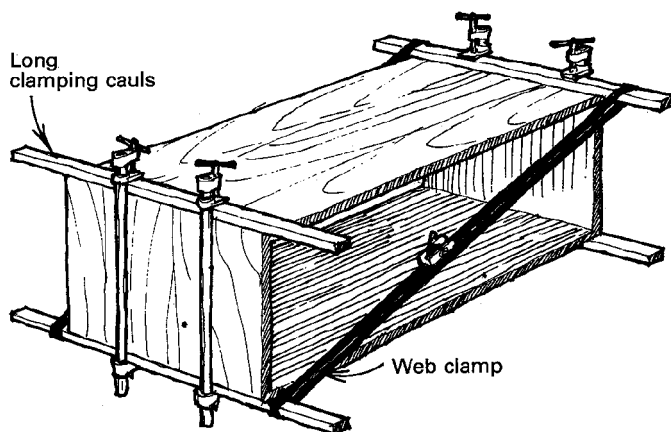

To square a cabinet, I use a pair of web clamps in conjunction with extra-long glue cauls. During glue-up, I determine in which direction the cabinet is out of square. Then, a web clamp is placed across the long diagonal, one on each side,

and they are tightened. The cabinet is square when the diagonals are equal in length. This procedure is easy and exact, and best of all, these clamps can't slip and fall off when you finally get the cabinet square.

—Mark G. Carls, Juneau, Alaska

Quick tip: To keep tiny drill bits from breaking, slip a sponge-rubber ball, like the ones children use to play jacks, over the bit before you use it. The point of the bit should just protrude from the ball. The ball gives the bit extra support and compresses as the bit goes into the stock.

—Donald F. Kinnaman, Phoenix, Ariz.

Lawn mower height adjusters on tool stands

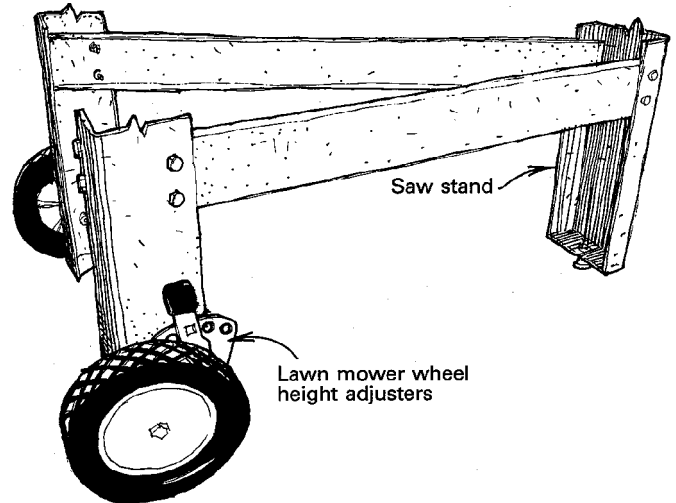

By attaching lawn mower wheel height adjusters to your tool stands, you can add portability without disfiguring the equipment. In my case, I fitted the height adjusters (Arnold model HA700) along with 6-in. lawn mower wheels to the two front legs of my 140-lb. scroll-saw stand. The adjusters and wheels are readily available at small-engine repair shops and simple to attach by following the manufacturer's instructions on the back of the package. Just be sure that the stand will sit on the floor when the wheels are all the way up.

—Donald G. Hulsey, Tucson, Ariz.

Quick tip: Sand the small openings in a grill with a detoothed sabersaw blade that has sandpaper strips glued to its sides. Using fine sandpaper for the strips will reduce cross-grain sanding marks.

—David E. Evenson, Cumberland, Wisc.

Fitting legs to a turned pedestal

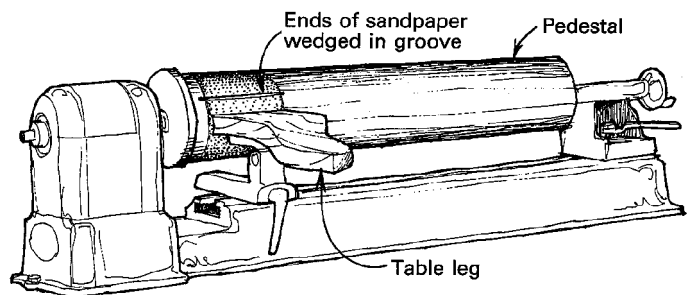

Recently I built a pedestal table with four legs that were attached with hanger bolts secured by nuts inside the hollow pedestal. The

problem I faced was machining a concave surface on the joint surfaces of the legs so they would mate with the cylindrical pedestal. A simple machine setup did not seem obvious and carving the leg profile with hand tools seemed like an all-day job. Thinking that a drum sander the same size as the pedestal would be just the thing, I happened to look over at the pedestal still on the lathe and things clicked. I decided to wrap sandpaper around the pedestal and use it as a sander.

I selected a 6-in.-wide E-weight paper belt to do the work. To hold the paper in place on the pedestal, I routed a groove $\frac{1}{8}$ in. wide and $\frac{3}{8}$ in. deep where one of the legs would be attached. I then tucked the ends of the sandpaper into the slot and secured them with a wooden wedge.

To sand the legs, I simply propped the leg on the tool rest, pushed the surface into the rotating pedestal and frequently checked the progress of the sanding. I was able to make small adjustments in the angle and pressure to keep the profile accurate. The profile cut by this method is off by the thickness of the sandpaper. However, the fit can be improved quickly by scraping the middle of the surface -with a curved scraper.

The best thing about this method is the thought that someday someone will repair or refinish the table. They will take off the legs and ask "What in the world is that $\frac{1}{8}$ -in.-wide groove for?"

—Frank D. Hart, Plainfield, Ind.

Quick tip: If airborne sawdust is a problem when working on-site or in a shop not equipped with a dust collection system, here's a solution. Drop a furnace filter on the back of a portable room fan, the kind that's about 22 in. square and sits on the floor. The suction holds the filter in place and clears the air in minutes .

— Ed Muldoon, Mt. Prospect, Ill.

Worry-free chisel grinding

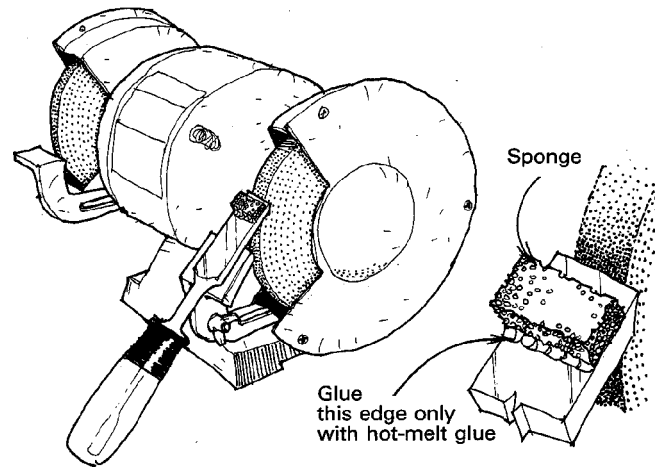

When grinding plane irons or chisels, I first attach a small piece of dried sponge near the cutting edge with hot-melt glue. Then, before grinding, I dip the sponge in water until it is well soaked. Because the wet sponge keeps the edge cool, I can grind away in a continuous operation without worrying about me or the iron losing our tempers.

—Don Klimesh, Broumstoum, Pa.

Reverse images for animal carvers

I discovered a simple solution to a perplexing problem wood-carvers often face. Like other carvers of birds and animals, I use pictures to ensure I get all the details right. But a picture

shows only one side of a figure. And to work on the left side of a horse, for example, using a picture of the right side is confusing and difficult.

The solution is to have the picture duplicated on transparent film at a graphics or blueprinting supplier. It costs about one dollar a copy. Then, you have views of both the left and right sides simply by flipping the film over. By the way, an excellent animal reference source for carvers is *An Atlas of Animal Anatomy for Artists* (Dover Publications, 180 Vanick St., New York, N.Y. 10014).
—George Meuse, Hockessin, Del.

Spring-loaded locking pins for toolboxes

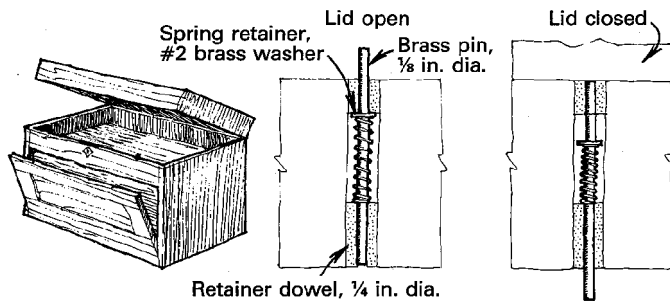

After building a toolbox that opened from both the front and top, I wanted commercial hardware that would automatically lock the front whenever the top was closed. I couldn't find anything that would do it, so I designed my own spring-loaded locking pins.

Make a full-scale sketch of the mechanism to find the length of the pin, where to solder the spring retainer, etc. Then, cut the pin

from 1/8-in. brass rod and use a #2 brass washer for the spring retainer. You can hand-ream the hole in the washer to 1/8 in. with a drill bit, and then push the washer onto the pin and solder it in place. Cut the 1/4-in. retainer dowels to length and bore a hole, slightly larger than the pin's diameter, down the center of each.

Now, drill 1/4-in.-dia. holes in the front apron of your toolbox for the retainer dowels. Glue the bottom retainer dowel into place. Then, place a ball-point pen spring on each pin, insert the pins into the holes and hammer the top retainer dowel into place. I left the top dowel unglued so I can disassemble the pin mechanism if it needs repair.
—David Van Ess, Arlington, Wash.

Quick tip: An indispensable aid in my shop is a 25-lb. bag of lead shot. I use it to hold down sliding jigs on the tablesaw, dampen vibrations in delicate workpieces and weigh down hard-to-clamp joints for gluing.
—M. Felix Marti, Monroe, Ore.

Long-reach clamping

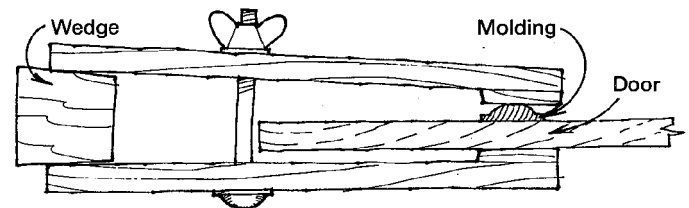

Most C-clamps do not have very long reaches and special long-reach clamps are too expensive to have around for just occasional use. So, when I needed to glue molding on the flat face of a door, about 5 in. from the edge, I adapted a system I used

in my boat-building days.

In boat work, when parts had to be held together far from an edge, we fastened two boards loosely together with a nut and bolt. Then, we adjusted the bolt so that when a wedge was driven between the open ends, the other ends would clamp down on the parts.

For my door molding application, driving a wedge into the clamping strips would have moved the molding. So I carefully placed the wedge in position without hammering and then simply tightened the clamp arms with a wing nut.

—Percy Blandford, Stratford-upon-Avon, England

Shopmade vise design

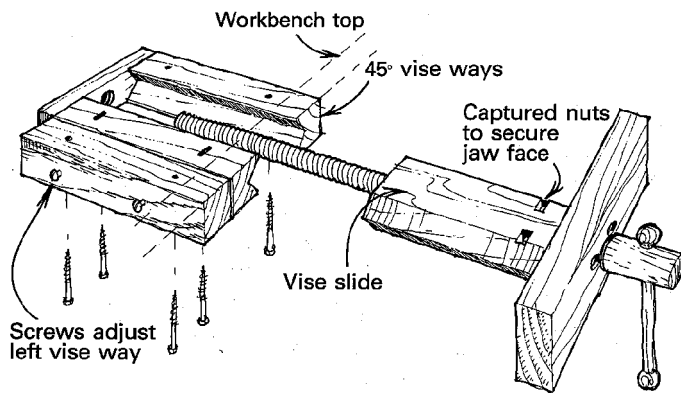

Since my traditional woodworker's workbench is not located against a wall, I decided to add a third vise on the back side across

from the tail vise. The ways are designed like a cross slide on a metal lathe, and they consist of two 45° channeled blocks that are mounted under the bench with lag screws. One of the ways is adjustable, as shown in the drawing, to allow for humidity changes.

I attached the face of the vise to the slide with 5/16-in. bolts and captured nuts. Originally, I built this vise using 3/4-in. threaded steel rod. Later, I acquired a 1-in. wood threading outfit and have now converted the screw to 1-in. wood. Both the vise body and screw are hickory.

—James L. Dunlap, Hartsville, S.C.

Quick tip: If troubled by machine lock-knobs vibrating off, spread a small dab of beeswax on their threads. This seems to work indefinitely.

—Dixon Corum, Jackson, Tenn.

Spiling for making patterns

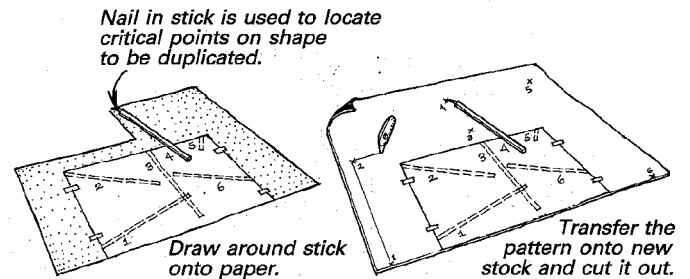

Spiling is a method for making very accurate patterns for flooring or countertops. A nail in one end of a stick is placed at critical points on the to-be-duplicated shape and the other end is traced onto a piece of paper. The paper and the stick can then

be used to transfer the critical points onto the stock to be cut out, allowing perfect reproduction of the original shape.

Here are tips that will help when spiling. Work clockwise and number each recording consecutively. It may help to make a quick sketch showing the locations for the numbered points. It simplifies the process if you can work from a straight edge. Tape the paper on this straight edge and measure from one side of the paper to one end of the straight edge. Using this measurement, locate the paper on a straight edge of your new stock and mark the pattern.

—Lynn Mickelson, Seattle, Wash.

Another featherboard

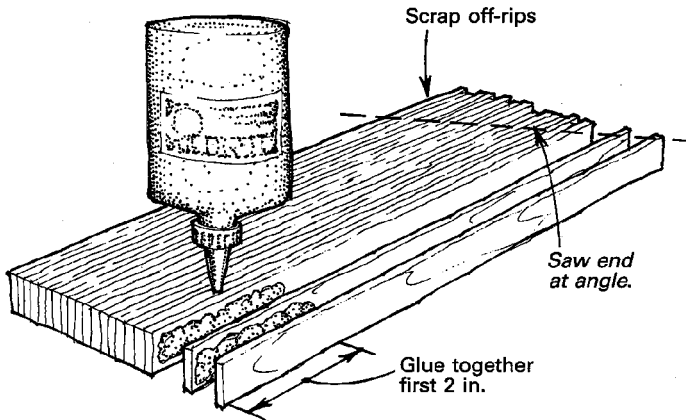

Periodically, as I'm processing lumber on the tablesaw, I'll generate a large number of small flexible off-rips that are

identical in size. This is something I'm sure many woodworkers have encountered. So a few years ago, I started recycling some of these scraps into useful materials—featherboards.

I start with enough 1-ft.-long pieces to make a board 3 in. or 4 in. wide, dab glue on just the first 2 in. or so of each piece and clamp the lot together. If they misalign slightly during clamp-up, I just run the newly made "board" through the planer and trim the end to the angle I want. Now, the featherboard is ready for use. I like to screw two featherboards to a baseboard and then clamp the base to the tablesaw. I set the featherboards so one contacts the workpiece just before it enters the blade and the other just after it exits.

—M. Felix Marti, Monroe, Ore.

Quick tip: When making intricate cuts on the scroll saw or bandsaw, first cut out the pattern from paper and then stick it to the wood with clear tape. I have found that this pattern is much easier to follow than a dim pencil line.

—Charles H. Price, Winnsboro, Tex.

Quick tip: To avoid first-degree burns on my fingertips whenever I build up a head of steam with a cabinet scraper, I wear the rubber finger caps, commonly used for sorting paper. Besides deflecting the friction heat, the caps, available at office supply stores, provide a slip-free grip.

—Steve Barren, Kalispell, Mont.

Methods of Work buys readers' tips, jigs and tricks. Send details, sketches (we'll redraw them) and photos to Methods, Fine Woodworking, Box 5506, Newtown, Conn. 06470-5506. We'll return only those contributions that include an SASE.

Rack for clamping pipes

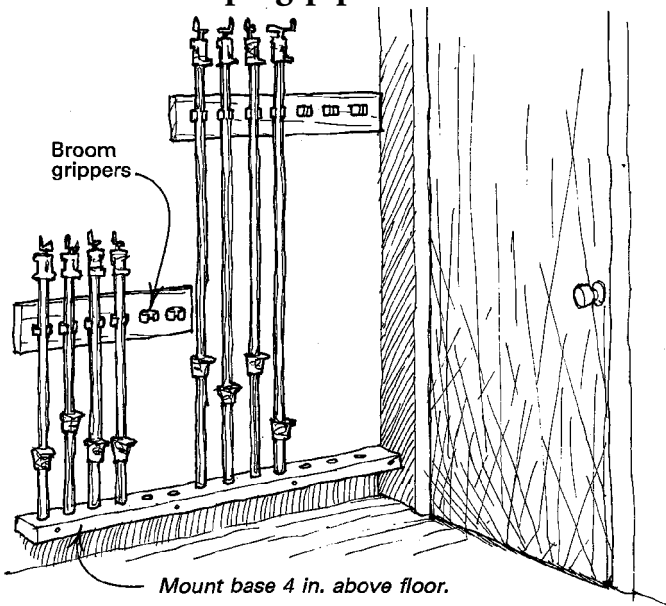

Since I normally over-complicate things, I surprised myself when I came up with this simple and effective pipe clamp rack for $\frac{3}{4}$ -in. iron pipe. It uses standard spring-metal broom grippers, the kind you can find at most hardware stores, to hold the pipes. The broom grippers are screwed to plywood strips that are in turn screwed into wall studs. The base of the rack is a 2x4 with $\frac{1}{4}$ -in.-dia. holes drilled halfway through to hold the ends of the pipes. Use drywall screws to mount this base to studs 4 in. off the floor so you can sweep under it. If you have a wide range of clamp lengths, as I do, you may need two or more tiers of grippers. I installed the unit behind a door to make effective use of the narrow space.

—Kevin Stamm, San Francisco, Cal.

Quick tip: When waxing the bed of your planer, don't skip the chipbreaker and pressure bar. It makes a difference.

—Robert Vaughan, Roanoke, Va.

Repairing chair parts with bandsawn combs

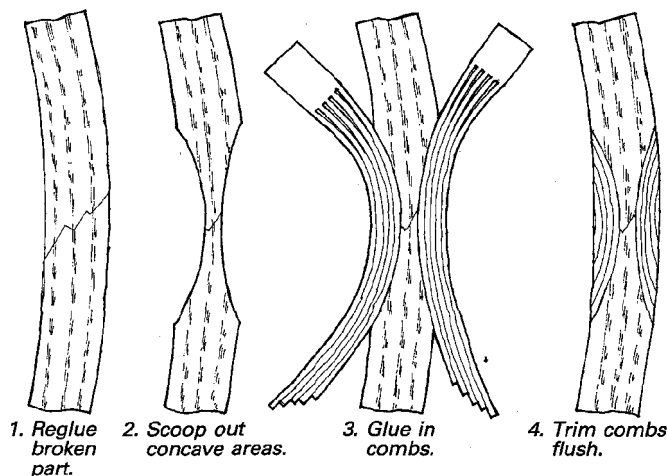

Here's a quick and easy technique I first used to repair a Windsor chair back that had broken almost straight across the grain. The key is gluing comb-like splints into scooped-out areas on each side of the break. The repair is strong and nearly invisible.

First, glue the break together to properly align the pieces and hold them together. Then, with a rasp or the nose of a belt sand-

er, scoop out a curved section on each side of the break to hold the repair inlay. Make the comb-like inlay by kerfing a block of matching wood on the bandsaw. The result is similar to a bundle of veneer pieces held together at one end. Now, apply glue between the layers and clamp the laminated inlay into the scooped-out area. Because the layers are from a single piece of wood, the grain and color match of the laminations will be perfect.

—Walter Stanul, Maiden, Mass.

Quick tip: Tongue depressors are handy for spreading glue, stirring paint, padding clamps, shimming and so on. They're available at drugstores in boxes of 750 for less than a penny each.

—Stanley Bessent, Goldthwaite, Tex.

Sharpening a spokeshave blade

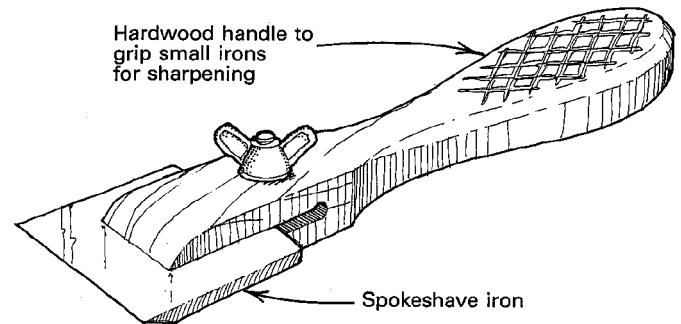

I use spokeshaves quite often in my work, but their narrow irons are difficult to hold onto while sharpening. To overcome this problem, I made a handle from a scrap of hardwood, a carriage bolt and a single wing nut, as shown above. It grips any size iron and provides excellent control during both grinding and honing.

—Dennis R. Mitton, Gig Harbour, Wash.

Quick tip: To avoid chipping the veneer when sawing cross-grain dados in plywood, make two passes. Cut through only the face veneer on the first cut, and then make a second pass to full depth.

—John Kriegshauser, Kansas City, Mo.

Rubber-strip clamp

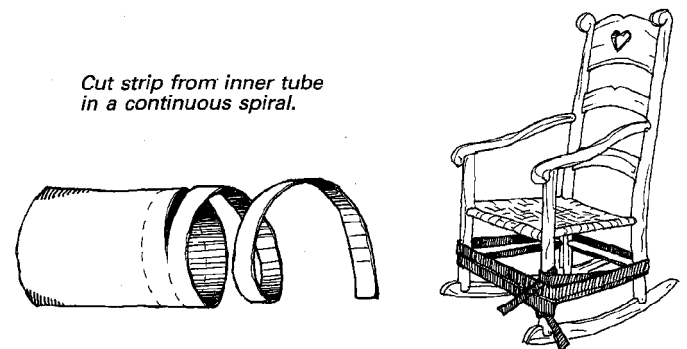

One of the most versatile clamps in my shop is a 1-in.-wide strip of rubber from an old inner tube that I cut in a continuous spiral. I've used the clamp for some of my trickiest jobs, like edging plywood, clamping picture frames, regluing chair legs and repairing a gusset brace on an antique chair. The strip is also handy as a supplement to conventional clamps on some jobs. But versatility is not the clamp's only advantage; it costs nothing and will never mar the work.

—Bernard Pearson, Mississauga, Ont., Canada

Quick tip: The flexible rubber bowls that art-supply stores sell for mixing casting materials are perfect containers for mix-

ing plastic resin and epoxy glues. Let leftover glue set up in the bowl. The next day simply flex the bowl and the residue will cleanly fall away.

—Rich Kjarval, Chicago, Ill.

Slot-cutting jig for splined miter joints

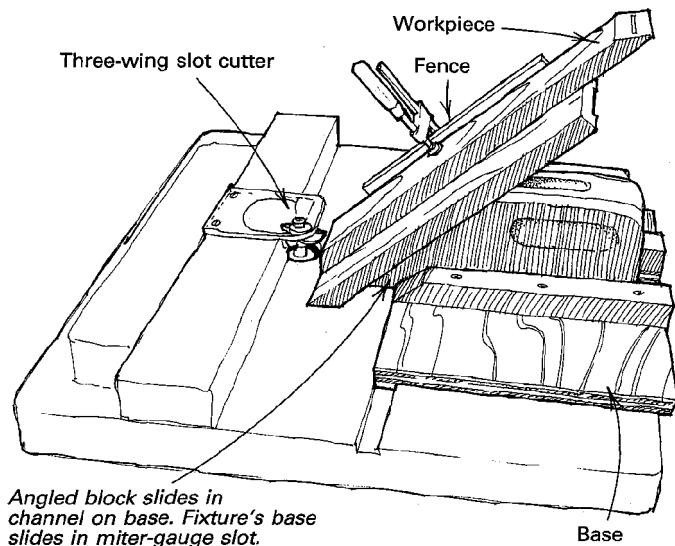

I've found that expensive slot-cutting machines aren't really needed for plate joinery. A $\frac{3}{8}$ -in.-wide, three-wing slot cutter mounted in a router table works -well. To use the router for edge-to-edge plate joinery, hold the right end of the work securely as you push the

edge into the cutter and rout a slot slightly longer than the biscuit.

Cutting the spline slots for mitered frames, however, is not quite so easy and requires a special fixture like the one shown in the drawing. The fixture's base rides in the router table's miter-gauge slot and two pieces of $1\frac{1}{4}$ -in. by $1\frac{1}{4}$ -in. stock are screwed to the base to form a channel perpendicular to the miter-gauge slot. Within this channel, a block of wood with one end cut at a 45° angle slides toward or away from the three-wing cutter. Finally, a board with a fence screwed to one edge is mounted on the angled surface of the block to register the workpiece and provide a clamping perch.

To use the fixture, clamp the mitered workpiece on the 45° block and push it into the cutter. You can cut a longer slot by moving the base of the carriage in the miter-gauge slot. Make pencil marks on the face of the workpiece to designate the ends of the slot; in production situations, clamp stop blocks to the top of the router table to limit the length of the slot.

—Jim Christo, Jamestown, N.Y.

Quick tip: For those woodworkers whose eyes itch and water in a dusty environment, try a pair of swimming goggles. In addition to sealing out the dust and protecting your eyes, the goggles won't fog up when you're wearing a dust mask.

—David M. Lesko, Norwalk, Conn.

Magnetic honing handle

I have always found the job of flattening and honing the back of a small plane iron a tedious chore, primarily because the only way to hold the iron flat and simultaneously move it across the stone is to grab it by its narrow, oily edges.

Recently, I was truing up a spokeshave iron amid the debris

on my bench which included, by chance, an old set of hi-fi speakers. Out of frustration at trying to grip the small iron, I grabbed one of the button magnets from a speaker cone and plopped it on the reverse side of the iron. The thing gripped like a bulldog and instantly my iron had a handle on the back that allowed me to exert both downward and lateral pressure with one hand, making the whole procedure much quicker and easier. The magnets I use, which are about 1 in. in diameter, are powerful enough to work with larger bench-plane irons and are encased in metal that's conveniently shaped very much like a drawer knob. —*T. Breece Rucker, Deddington, England*

Snug fits with cork

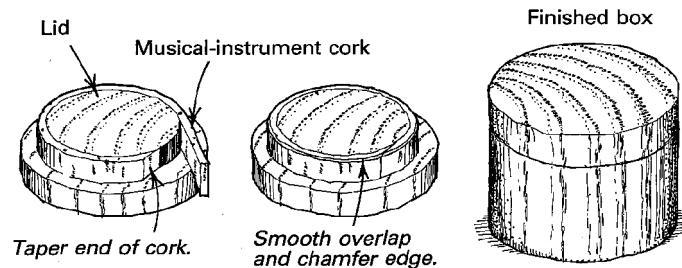

Turning a lid for a wooden container that will fit perfectly year after year is very difficult. The lid and container usually expand and contract slightly differently and, over the years, go from round to oval in shape. The problem is even worse when you turn containers from wild-grain crotches and burls. The solution to this problem is a tried-and-true method that musical-instrument makers have used for centuries to guarantee snug

fits between sections of woodwind instruments like oboes and clarinets: line the mating parts with cork.

Musical-instrument cork is available from instrument repair suppliers (Ferree's Band Instrument Tools and Supplies, Box 259, Battle Creek, Mich. 49016 is one such supplier) in 4-in. by 12-in. sheets in various thicknesses up to $\frac{1}{4}$ in. I prefer the $\frac{1}{32}$ in. thickness. Musical-instrument cork is sliced from the cork oak tree much like veneer and should not be confused with the inferior pressed cork found in hardware stores. I wouldn't trust the pressed cork to stand up to the strains of removing and replacing a lid.

To install the cork, turn the lid's tenon slightly smaller than the diameter of the container's opening. I suppose the exact undersizing of the lid tenon could be carefully measured, but I just approximate. Now, cut a cork strip from the sheet that's just a bit wider than the tenon and long enough to completely wrap around the lid's tenon with some overlap. Taper one end of the strip with an emery board and glue the strip to the lid with contact cement. Don't forget to apply cement to the tapered area.

Now, trim off the excess cork and sand the overlap until it's the same thickness as the rest of the cork ring. Chamfer the leading edge of the cork with the emery board so that the tenon will enter the container mouth without tearing the cork. Finish up by applying cork grease to the joint. Cork grease, which is available in every music shop in the country, acts as a lubricant to ensure the lid will come off easily. Some people may find the smell of cork grease objectionable, but I like it; it reminds me of band rooms.

—*Ken Hopps, Tacoma, Wash.*

Quick tip: To make threads on the end of a wooden dowel, I buy a hex nut of the appropriate thread and size and saw it in

half with a hacksaw. I place the two halves around the end of the dowel and press the whole works in a vise. A 1-in. #8 hex nut is just right for mending a broken push-broom handle.

—Mark Workman, Walnut, Cal.

Pivot for weather vane

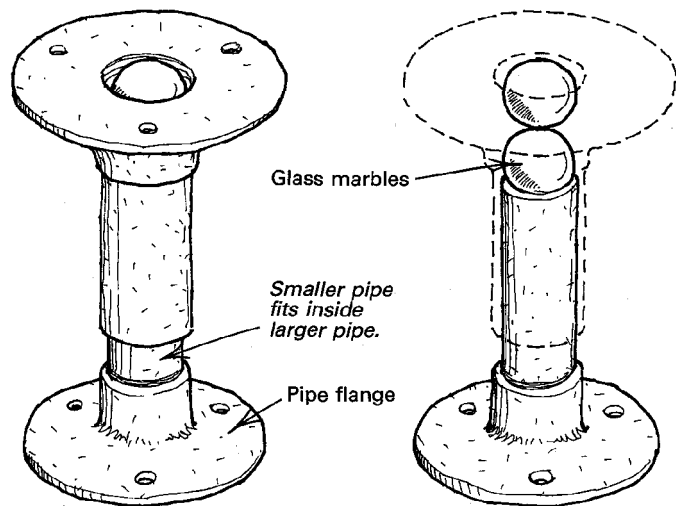

Here's a rust-proof, pivot-and-bearing surface for a weather vane, bird feeder or anything else you want to be rotated by the wind. As shown in the drawing, use two glass marbles as bearings inside of two pipe sections that fit one inside the other without too much play.

—Robert H. Schrader, Carrollton, Ohio

Quick tip: Large binder clips, available at any stationery store, make excellent small spring clamps. Other uses include fastening sliding measuring sticks and serving as a reference stop on a radial-arm saw fence.

—Stephen Agace, Hemdon, Va.

Tablesaw tenoning fixture

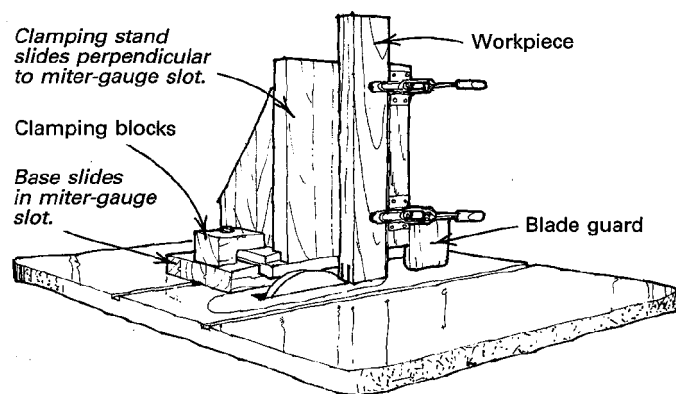

A good tablesaw tenoning fixture must be heavy, strong, rigid and accurate. That's why I made my massive tenoning fixture from an old laminated-maple, science-lab tabletop. The fixture has two main parts: a base that slides in the miter-gauge slot on a steel key and a vertical clamping stand that slides across the base perpendicular to the miter-gauge slot. Clamping blocks are bolted into the base to hold the vertical stand in place after it's been moved into position to cut the correct-size tenon. Permanently attached lever-action clamps, like those by De-Sta-Co., screwed

to the fence on the vertical stand hold the workpiece. As a safety feature, I added a blade guard on the trailing end of the fixture.

On production runs, I cut the tenon in one pass by mounting two identical blades separated by spacers, which set the final thickness of the tenon. Normally, though, when I have just one or two tenons to cut, I use a single blade and flip the workpiece for the second cut.

—Joe Moore, Brockville, Ont., Canada

Making raised panels on the jointer

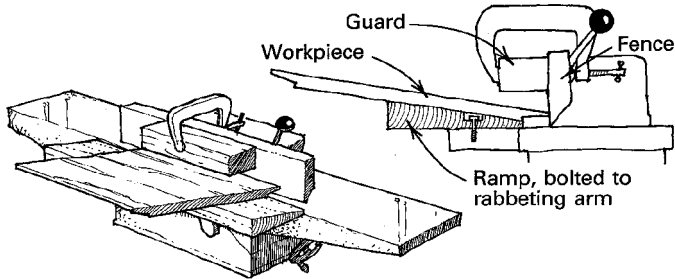

As a high-school woodworking teacher, my students and I have been cutting raised panels on the tablesaw for years. It's an altogether unsatisfactory method that at best is awkward, leaves burns on the bevel and doesn't feel safe. In addition, the slightest tilt of the stock creates a cavity that is time-consuming to sand out.

I finally purchased a monster 5-in.-dia. panel-raising cutter for our large shaper. But when I mounted it and turned on the shaper, the combination of the gaping hole in the table and the helicopter noise of the cutter winding up to 10,000 RPM was enough for me to shut down the shaper without even a trial cut.

There's no way I would let students cut panels on this machine.

So, I was left with the same old alternatives: jigs for the table-saw, radial-arm saw, router or—wait a minute, why not the jointer? After a couple of encouraging but unsatisfactory prototypes, I finally found what I was looking for—a safe, easy method that produces beautiful results.

The key to the method is a beveled ramp that's bolted to the jointer's rabbeting arm. I make the ramp by bandsawing a board at a 10° bevel and then truing up the sawn face on the jointer. Take the time to ensure that the bevel is identical at both ends. Then, drill and tap holes in the rabbeting arm so you can bolt the ramp to the arm. Make sure the inside edge of the ramp is parallel with the fence and right over the left end of the knives. You have to remove the regular cutterhead guard to use the ramp, so install a wooden guard block on the fence as shown in the drawing. The width of cut is adjusted with the fence and the depth of cut with the infeed table. I found that 1/16-in. cuts produce good results. Just lay the stock on the ramp with its edge up against the fence and use a push block to run it over the cutterhead. Beveling the cross-grain ends first and then following with the grain will reduce tearout at the end of the cuts.

The bevel angle may be changed by making ramps of various angles or making an adjustable ramp. Some jointers might require different mounting methods, but the important thing to remember is that the ramp is mounted to the infeed table.

—Joseph R. Robison, Freelandville, Ind.

Methods of Work buys readers' tips, jigs and tricks. Send details, sketches (we'll redraw them) and photos to Methods, Fine Woodworking, Box 5506, Newtown, Conn. 06470-5506. We'll return only those contributions that include an SASE.

Shop-built universal vise

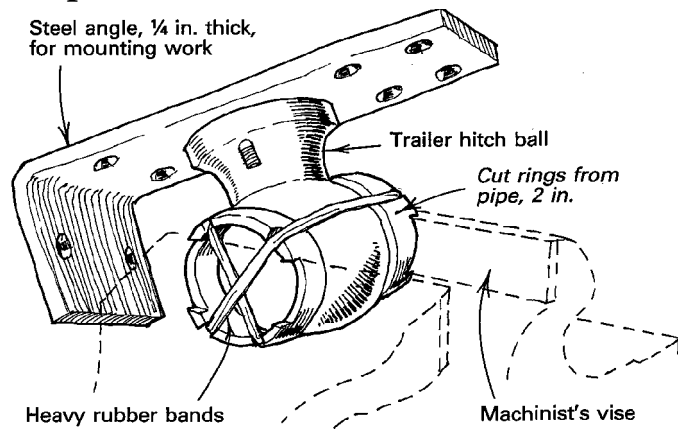

This simple homemade vise adaptor is made from an old trailer hitch, two 1-in.-long sections of 2-in. pipe and a chunk of 1/4-in.-thick steel angle. It allows the workpiece to be set at any angle for wood sculpting and decoy making. And it is massive enough and grips tightly enough to withstand the heavy blows of a large mallet without slipping out of position. The only limiting conditions are the size, strength and rigidity of the machinist's vise and the bench it's attached to.

To make the device, cut the stud off the trailer ball, and then drill and tap two or three holes in the ball's flange to fasten it to the steel angle. Chamfer the inside diameter of the pipe rings where they hit the ball, and grind or file a channel in each ring to fit over your vise jaws. This keeps the rings from slipping out of place when you loosen the vise. In addition, file or grind shallow notches in the rings for heavy rubber bands to hold the assembly together snugly while mounting it in the vise or for storage.

—E. Kawecki, Franklin, Mich.

Quick tip: When the blade slot on my radial-arm saw table gets too wide, I fill it in with a paste made from talcum powder and epoxy glue. When this tough filler has cured, I block-sand it flush and make a fresh cut.

—Richard Rubasch, Viroqua, Wisc.

Turning whitewall tires for toy cars

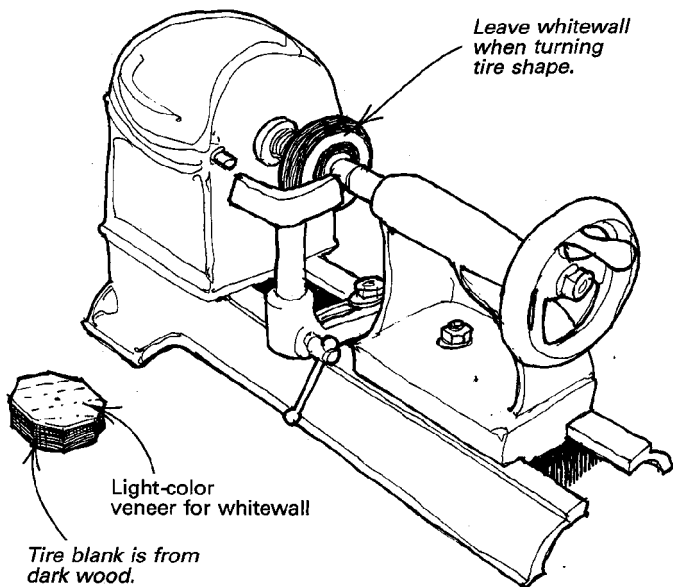

Here is a fast, easy way to make small whitewall tires for toy cars. Start by choosing a dark wood, like mahogany or walnut. Plane

the stock to the final thickness of the wheel, and then rip and crosscut as many square wheel blanks from the stock as you will need. Next, glue a piece of light-color veneer to the face of each blank. The veneer will later become the whitewall on the tire, and so it should contrast with the darker wood. After the glue has set, trim the corners off each blank to form a rough octagon, and drill a 1/8-in. or smaller hole through the center of each blank to locate the lathe's centers. Bore this hole with a drill press or drill guide to ensure that the hole is perpendicular to the wheel's face.

Mount a blank between lathe centers, veneer-side out, and turn the wheel in a conventional manner. As you shape the tire, you will expose the darker wood and leave the white veneer on the fattest part of the tire and in the middle. Work carefully—it's easy to make the whitewall too narrow. I usually turn only the outside face because in most cases, the other side doesn't show. The live center marks on the back will be hidden, and the ring left by the dead center on the front doesn't hurt the design's effect.

To give the effect of a tire tread, apply a metal-lathe knurling tool to the edge of the wheel after sanding and while the lathe is running at a slow speed. When the wheel is finished, redrill the alignment hole to the size needed for the axle.

—E.D. Groves, Starkville, Miss.

Quick tip: Boric acid powder is an excellent dry lubricant for sticky drawers, saw tables, jigs and the like. Simply sprinkle the powder right on the surface. Boric acid is a common non-prescription anti-bacterial agent, available in any drug store.

—Bill Hayman, Annapolis, Md.

Installing jointer knives accurately

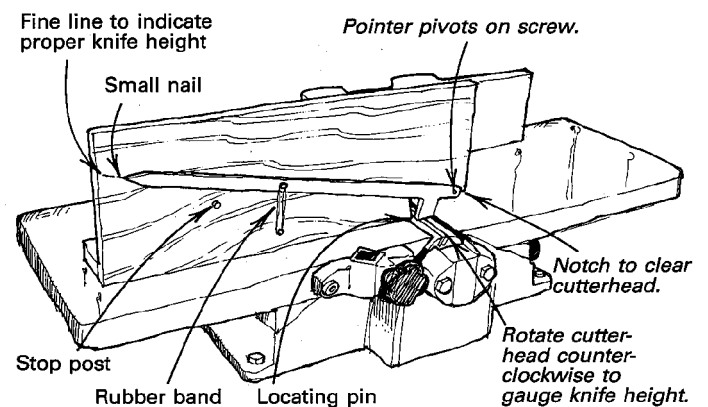

I finally got fed up with spending one hour carefully installing jointer knives and still having one knife get dull before the others because it was set higher. So I made the gadget shown in the drawing above to help. It's basically a simple gauge that, once calibrated to proper knife height, can be used to quickly and accurately set the knives.

Join two pieces of plywood at right angles so the wider board will stand on edge on the jointer's outfeed table. Notch the lower right end of this construction where it overhangs the cutterhead. Then insert a small dowel or screw in the bottom edge of the upright just behind this notch to act as a locating pin. This pin registers the position of the gauge against the end of the outfeed table. Screw the pointer to the lower right corner of the upright board, above the notch, so it will pivot when the knife to be set pushes up on the short lever that extends down from the attached end of the pointer. Use Plexiglas or hardwood for the pointer's lever, and insert a small nail in the other end for a more precise reading. The longer the pointer, the more the vertical movement of the knives is amplified; a 20-in.-long pointer will magnify the movement about 40 times.

To calibrate the gauge, you must first establish the proper

height for the knives. To do so, place a wooden straightedge on the outfeed table and raise one end of one of the knives until it grabs and moves the straightedge horizontally about $\frac{1}{8}$ in. to $\frac{3}{16}$ in. when the cutterhead is rotated clockwise.

Next, record this knife height by standing the gauge in position on the outfeed table with its lever over the knife you just set, as shown in the drawing on the previous page. Rotate the cutterhead counterclockwise and mark a fine line on the gauge's backboard at the highest spot the pointer reaches. Set the other knives by raising or lowering them until the pointer hits the same high spot when the cutterhead is turned counterclockwise.

—David Marshall, Gwynedd, Wales, Great Britain

Improved benchdog

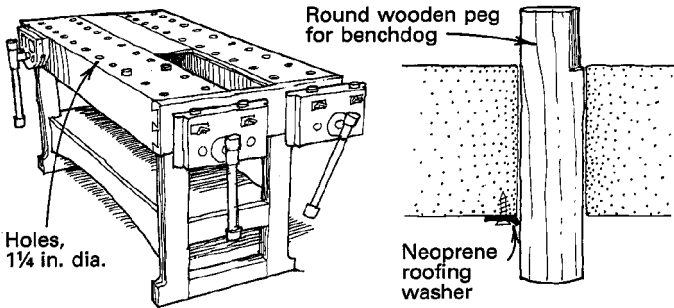

The European rectangular benchdog has two faults. First, it loses friction as the tapered spring is compressed, making the dog drop flush with the benchtop just when you would like it to remain up. Second, it can't be rotated for curved work.

My round benchdogs solve both these problems. To accommodate the dogs, drill a series of 1 1/4-in.-dia holes in your benchtop. Then, flip the bench over and screw a neoprene roofing washer alongside each hole so that the washer overlaps the hole a little; the more overlap the firmer the dog. Now, turn a length of dowel to a scant 1 1/4 in. dia. and crosscut it into suitable lengths for pegs. Sand or file a small flat on one end of each peg and presto—you have a peg that holds firm and rotates 360°.

—Jonathan Davies, Maleny, Queensland, Australia

Quick tip: After changing jointer or planer knives, write the date on a piece of masking tape and stick it to the base of the machine as a reminder to regularly attend to this necessary job.

—Robert Vaughan, Roanoke, Va.

Another captured nut technique

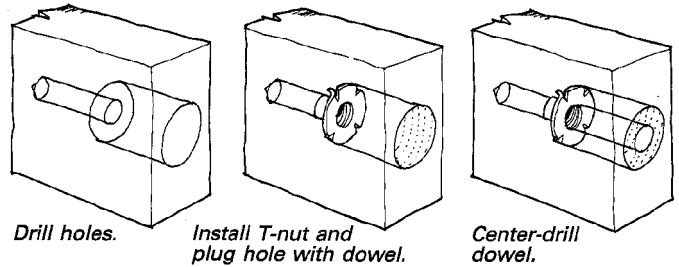

Here's another method for installing a captured nut in a wood member for knock-down furniture. First, drill a flat-bottom hole in the end of the member with a Forstner bit, which has a diameter slightly larger than a T-nut flange. Drill a second hole centered in

the first using a bit the same size as the T-nut barrel. The second hole must be deep enough for the end of the bolt that will extend beyond the nut when the joint is tightened. After driving the T-nut firmly into the larger hole, plug the hole with a glued-in dowel. Be sure the dowel butts hard on the nut, and don't use any more glue than necessary because excess glue will be forced into the threads of the nut. When the glue has set, center-drill the dowel with the smaller bit you used before and stop when you reach the T-nut. Go slow near the end so you will feel when your bit just touches the T-nut. —*John Burns, Pensacola, Fla.*

Sanding stepped edges

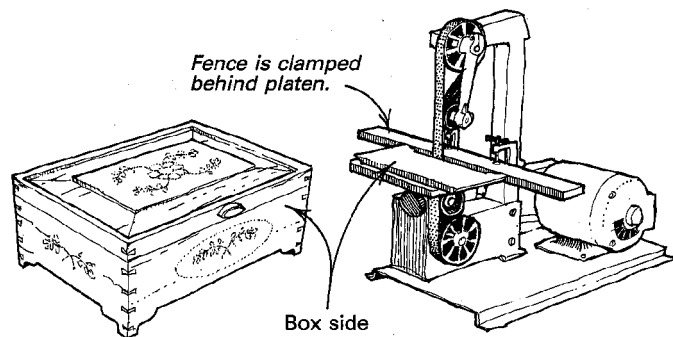

A while back, I ran into a problem while building a small jewelry chest. My design called for feet that were cut with a jigsaw right from the sides of the box. But no matter how carefully I sawed the straight part between the box's feet, the inevitable waverings ruined the look of what should have been a perfectly straight edge.

I solved the problem by clamping a wood fence on the table of my 1-in. belt sander behind the platen. I left about $\frac{1}{16}$ in. when I cut the bottom profile on the box sides, and I sanded the straight section of the edge by pressing it against the belt and moving the piece back and forth until the feet touched the fence. With the fence clamped at just the right distance behind the sanding belt and parallel to the platen, the result is a nicely sanded straight line that needs only to be cleaned up with 220-grit paper.

—*John M. Colombini, Pittsburgh, Pa.*

Quick tip: I got a couple of adjustable folding ironing boards at a flea market. When topped with laminate-covered plywood, they make great adjustable outfeed tables and also double as large folding sawhorses. —*James Fielding, Shawnigan Lake, B.C., Canada*

Trimming in a miter box

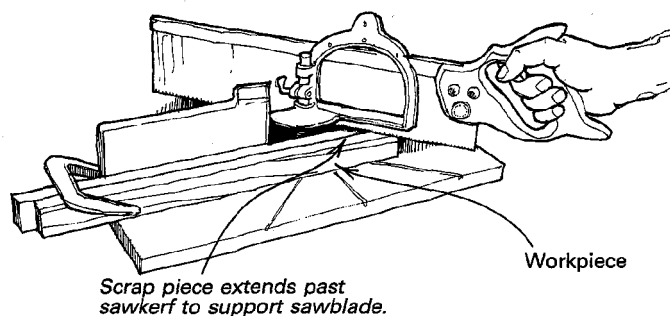

In order to achieve an extremely close fit with pieces of trim, I make the first cut a bit long and then trim the piece to perfect

size with repeated fine cuts in my miter box. However, when trimming less than a kerf's width, the sawblade will almost always deflect off the trim line. This problem can be eliminated by backing the piece being trimmed with a scrap of about the same dimensions. Clamp both pieces to the miter box with the scrap piece extending well past the sawkerf to support the blade behind the cut. This will ensure a perfect, no-deflection cut on the workpiece.

—Joseph Franchina, Coventry, R.I.

Quick tip: The filtering capabilities of a dust-collector bag can be easily improved by spraying the inside of the bag with no-stick cooking spray. This treatment will stop the finer dust with no loss in system efficiency.

—Robert Brandl, Ft. Worth, Tex.

Making dentil molding on a radial-arm saw

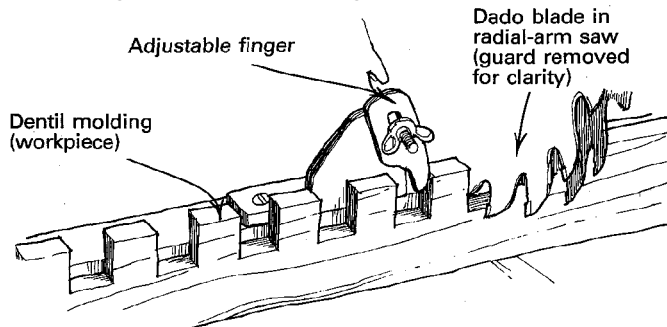

I needed several sticks of dentil molding for some bookcases I was building. My first inclination was to measure and mark each dentil and make the cuts freehand on the tablesaw, but this would be

time-consuming with no guarantee of accuracy. By using a dado blade on my radial-arm saw with an indexing finger attached to the fence, as shown below, left, I found I could cut the molding quickly and accurately. Adjusting the dado blade up or down determines the depth of the cutout, and the location of the adjustable finger determines the cutout's width. In the drawing, the blade guard has been removed for clarity, but don't attempt this operation without replacing the guard.

—Jack F. Sewert, Marion, N.Y.

Grooving a dowel

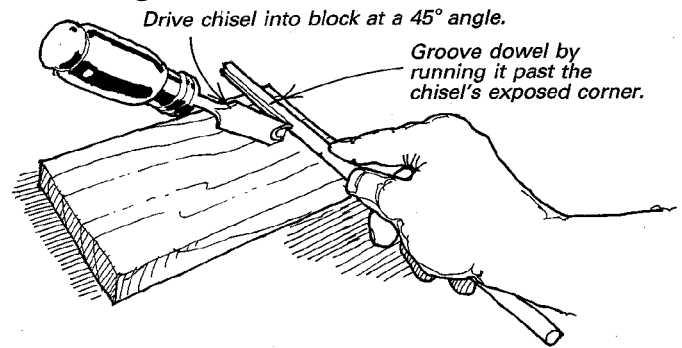

Grooved dowels are superior for doweled glue joints because they allow the glue to escape back along the sides of the dowel as it's inserted. An ungrooved dowel will push most of the glue into the bottom of the hole. Grooved dowels are commercially available, but here's a tip I often use to groove my own. Tap a $\frac{3}{4}$ -in. chisel into a block of wood at a 45° angle as shown above. The upper corner of the chisel should hit the centerline of the dowel. Now,

draw the dowel past the corner to form a series of grooves.

—John A. Graydon, Islington, Ont., Canada

Quick tip: A simple adjustment mechanism for benchdogs is to staple a 1-in.-wide strip of inner tube to the underside of your bench so that the rubber covers one-half of the benchdog hole. The rubber holds the dog at any height and allows the dog to be replaced quickly.

—Barrie Graham, Arundel, Que., Canada

Sphere-turning lathe attachment

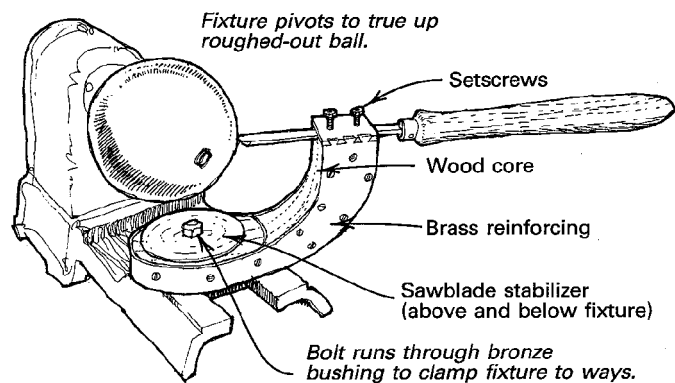

In 1946, a friend described a ball-turning device his machinist had made to fit an Atlas lathe. Unfortunately, I never got a chance to look at it. I've tried to design and make an attachment ever since, and recently I succeeded. Although the machinist had made the fixture entirely of metal, I used wood for the fixture's core and reinforced it on the sides with sheet brass.

The fixture bolts to the lathe's bed and holds a gouge at a height that's on line with the lathe's centers. Then, with the lathe running, the fixture is pivoted to make the final cleanup passes on a previously roughed-out ball. The final diameter of the sphere is determined by the projection of the gouge's tip from the block.

To make the fixture, I bandsawed the wooden core from an old bridge beam and machined the top and bottom of the base flat with a rotary planer in a drill press. Then, I drilled a $\frac{3}{8}$ -in.-dia. hole through the base to take a bronze bushing. The bushing's length is critical; it must extend from the tool-rest attachment bracket below the ways that I use for bolting the fixture to the lathe bed, up through the base of the fixture and $\frac{1}{64}$ in. above the upper steel plate. If the bushing is shorter, the fixture will be clamped tightly to the lathe and won't rotate; any longer and there will be too much slop as the fixture pivots. The steel plates are actually sawblade stabilizers from Sears (part no. 94952). They have a $\frac{3}{8}$ -in. hole, just right for the bushing, and act as large washers that the fixture's arm pivots between. Following a cardboard pattern, I cut out the $\frac{3}{32}$ -in.-thick hard sheet brass that surrounds the wood core, and drilled and countersunk it for screws. I used $\frac{1}{8}$ -in.-thick brass for the cap, which I dovetailed into the brass sides and tapped for the setscrews that hold the gouge.

The gouge sits in a groove cut into the top of the core under the brass cap. It's critical that the gouge's cutting edge be the same height as the lathe's center; so adjust the depth of the groove for the gouge you're using.

—Ralph M. Luman, Virginia Beach, Va.

Methods of Work buys readers' tips, jigs and tricks. Send details, sketches (we'll redraw them) and photos to Methods, Fine Woodworking, Box 5506, Newtown, Conn. 06470-5506. We'll return only those contributions that include an SASE.

Thickening with a power planer

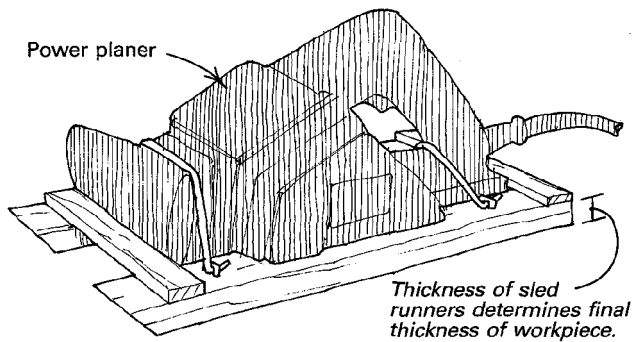

I don't have a planer. So when I needed to thickness stock for some custom moldings, I built this attachment for my hand-held power planer that makes quick work of thickening stock up to 3 in. wide. First, I built a wooden sled for the power planer to ride in, as shown in the drawing. The body of the plane is supported on the sled's runners and the sole drops down between them. I made the runners thick enough so that the distance from the bottom of the sole to the bottom of the runners was equal to the desired stock thickness. Two wires hooked through heavy-duty staples on the top of the sled runners hold the plane and sled together firmly.

To use the device, clamp the stock on top of a workbench between the bench's tail vise and wooden benchdogs. Then set the plane for a good heavy cut and have at it. Be sure to plane the entire length of the stock in each pass, and after a couple of passes, turn the stock over to true the other side. Continue making passes until the runners keep you from removing any more material. As you approach the last pass, the runners will automatically make the cuts lighter, leaving a smooth surface.

—Thomas Henke, Covina, Cal.

Workbench bar clamp stand

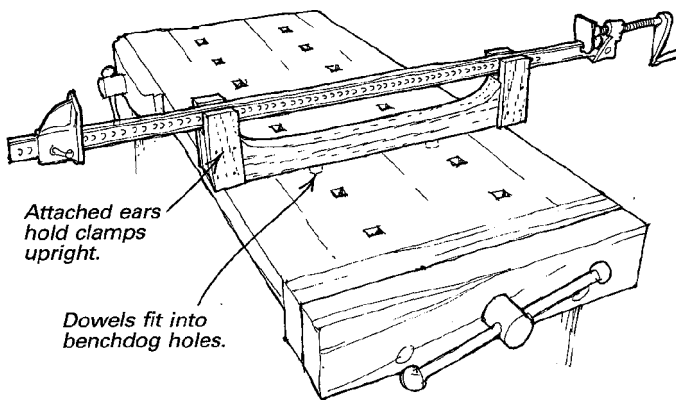

These simple little fixtures turn any workbench with two rows of benchdog holes into a clamping table. These clamp cradles reduce the wild scramble that accompanies gluing up edge joints, doors and face frames by holding a series of bar clamps ready and steady. To make one of the fixtures, cut a length of hardwood into a long U-shape, and glue or screw little ears on each end to hold the bar clamp upright (see the drawing). Then install dowels in the bottom of the cradle that fit into the benchdog holes in your benchtop. Make as many of the cradles as you'll need for your biggest glue-up.

—Tony Whitford, Norfolk, Va.

Quick tip: To find slow leaks in air hoses or tool connections, apply liquid dishwashing detergent to suspected leaking areas. Suds and bubbles soon tell the tale.

—Robert M. Vaughan, Roanoke, Va.

Plexiglas lathe guard

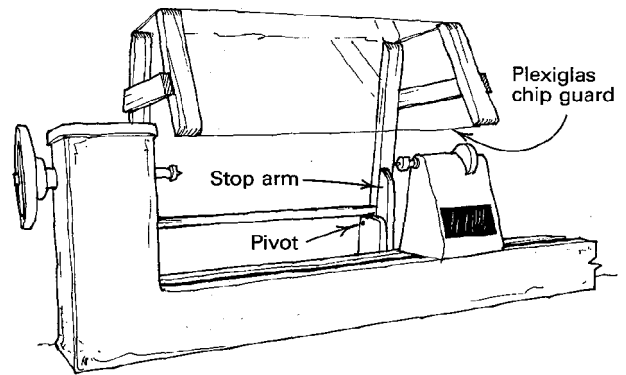

Since I couldn't find plans for a shopmade chip guard for a lathe, I built my own by adapting the best features from three of my friends' commercial guards. My guard, which consists of a hardwood frame and a 1/8-in.-thick Plexiglas shield, not only deflects the stream of chips and stops flying debris, it also makes dust collection more efficient. The guard is mounted behind the lathe on two bolts, as shown in the sketch, so it will pivot out of the way when necessary.

You can screw the wooden frame members to the plastic or attach them with contact cement. The only tricky part about building the guard is bending the Plexiglas. When you locate a local supplier for the Plexiglas, be sure to ask if the store can bend it to your specifications. If not, you can shape Plexiglas in your own shop by softening the plastic with an industrial heat gun (similar to a portable hair dryer) and then bending it over a shop-built form. Be careful not to overheat the plastic, and practice with small pieces until you get the hang of it.

—John I. Timby, Deming, N.M.

Quick tip: When sanding small parts that can't be gripped with your fingers, take a technique from the lapidary. Put a dollop of hot-melt glue on the back of the part and stick it on the end of a dowel. To remove the dowel, place the assembly in the freezer for a few minutes—the part will pop right off. This technique also works well for polishing small metal parts on a buffing wheel.

—Paul Marshall, Apache Junction, Ariz.

Milling large surfaces

Here is the procedure I used to accurately mill the surface of a 4-ft.-dia., 288-year-old ponderosa pine section destined for a museum exhibit. I utilized the shop door as a swinging vertical axis to which I clamped a horizontal beam and a diagonal brace, as shown in the drawing at right. I made a mounting bracket for the router so it could slide along the beam and be locked in position anywhere. Marks along the horizontal beam designated increments slightly less than the diameter of the surfacing bit I was using so I would know how far to move the router after each pass.

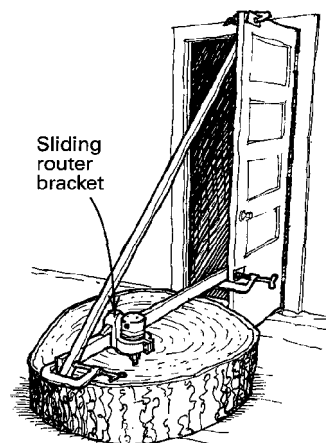

To use the rig, I leveled the tree section on the floor near the shop door. Then, I turned on the router and swung the beam and router assembly back and forth across the workpiece, mov-

ing the router one increment after each completed pass. I got the best results by swinging the beam first from right to left and then from left to right on each pass. On the first swing, the pressure from the cut raises the router slightly out of the workpiece; then on the back swing, the router removes just a whisker, producing an accurate surface requiring only sanding. If you aren't getting a flat surface, your door jamb is probably out of plumb.

—*Laurence I. Jayne, Davenport, Wash.*

Quick tip: Two jam nuts that acted as a depth stop on my drill press were always vibrating loose and inhibiting spindle travel. I replaced them with a $\frac{3}{8}$ -in.-long piece of $\frac{3}{8}$ -in.-dia. tube that slides over the depth rod. I secure it with an Alien setscrew tapped into the tubing.

—*Jack Rosenfield, Lakewood, Colo.*

Homemade burn-in sticks

Shellac sticks are used for making minor surface repairs before finishing. The stick is heated to melting with a hot knife and then pressed into the dent or gouge. You can make shellac sticks by heating a brass rod and rolling it in any form of flaked or powdered shellac. Repeat heating the rod and rolling it in the shellac flakes until the rod is well coated. Don't allow the shellac to flame; just get it hot enough so you can easily pick up more. Use the edge of your jointer or any cold metal edge to force the shellac off the stick. When the shellac is cool enough to handle, roll it between your palms to form it into a round stick. Both button shellac and orange shellac make excellent sticks for the darker hardwoods.

To make repairs with the stick, you will need an old table knife. Hold it and the shellac stick well above a propane torch or alcohol burner, with the knife shielding the stick from the direct heat of the flame. Melt the shellac onto the knife and press the

melted shellac into the defect in the wood. Smooth the repair with the flat side of the blade, and then rub out the shellac with fine steel wool or rottenstone. —*Ken Hopps, Tacoma, Wash.*

Quick tip: When facing plywood shelves with solid stock, do two at once. Glue and clamp a $1\frac{3}{8}$ -in.-wide strip of solid stock between two plywood shelves. When dry, rip down the middle of the solid strip. You'll have a $\frac{3}{4}$ -in. solid facing on each shelf in less time with fewer clamps. —*Brian J. O'Connor, Wolverine, Mich.*

Squirrel-cage fan and dust filter

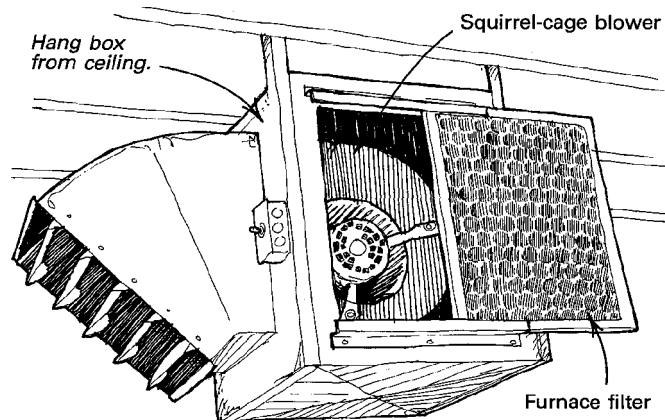

I was concerned about dust in my shop and had this filter setup made at a sheet-metal shop. For about \$140, I got the four-speed squirrel-cage blower in a custom box with a furnace filter on each

side. It hangs on the ceiling where it filters the air by removing airborne dust before it settles and then recirculates the filtered air with a whirlpool effect. —*John R. Thiesen, South Wales, N.Y.*

Quick tip: I apply liquid gun bluing to my steel tools not only to prevent rust, but also to deter "permanent borrowing." Oxpho-Blue, available from Brownells, Inc., Route 2, Box 1, Montezuma, Ia. 50171, is a good solution. — *R.S. Kjarval, Chicago, Ill.*

Carriage for bandsawing rough wood

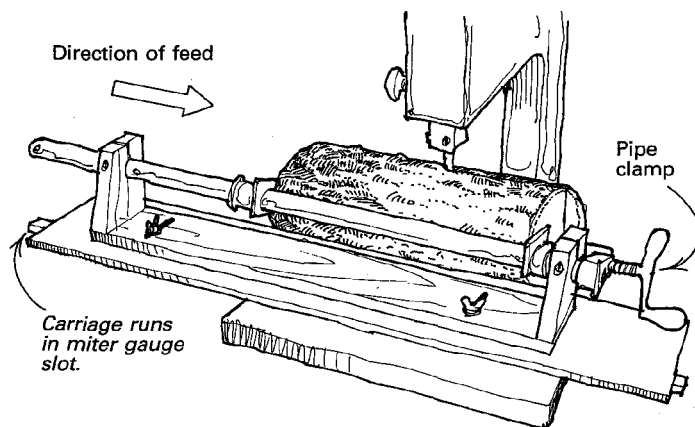

I'm always looking out for interesting hardwood scraps, split firewood and small logs for turning blocks. But hand-feeding the irregular shapes through the bandsaw to cut them into usable pieces isn't safe. I developed a solution based on my recollec-

tions of a rolling log carriage used in sawmills. I used the same basic idea, but scaled down the carriage.

I mounted a 3-ft.-long pipe clamp to a 2-ft.-long U-shaped maple bracket. To allow lateral adjustment, I slotted the bracket's bottom and fastened it to the base with bolts and wing nuts. A maple track glued to the bottom of the base slides in the saw's miter-gauge slot. When making the carriage, be sure the clamp jaws clear the band-saw blade with the bracket at its closest setting. To use the carriage, tighten the log in the clamp, adjust the bracket for the width of cut and feed the log past the blade. —*E.G. Lincoln, Parsippany, N.J.*

Integral circle guide for bandsaw

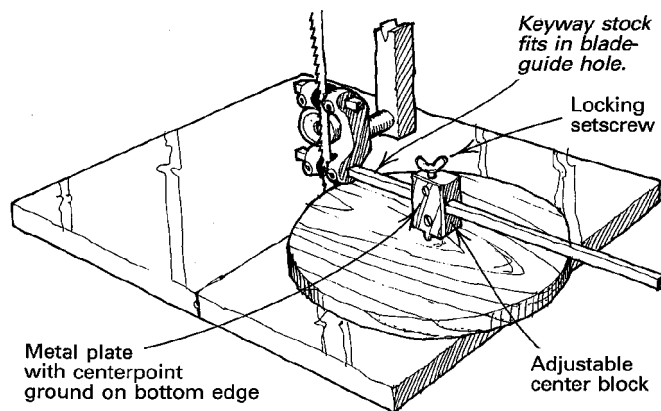

This circle guide uses a length of standard steel keyway stock, available from machine shops, as a replacement for the saw's upper right-hand blade-guide insert. Adjust the blade's thrust bearing and

tracking to be sure the teeth aren't damaged. Notch a small wooden block to fit on the keyway stock for an adjustable center point. Drill a slightly undersize hole in the center block's top, and tap threads in the hole with a thumbscrew that acts as a locking set-screw. Cut a spur on the bottom edge of a metal plate to act as a center pivot point and screw the plate to the block's front face.

To bandsaw a circle, set the center point at the desired radius by measuring over from the blade. Then, with the edge of the workpiece bumped up against the blade, lower the upper blade-guide assembly until its center point sets into the workpiece firmly. Now turn on the saw and slowly rotate the workpiece into the blade.

—Dean Martin, Loveland, Colo.

Expanding the range of a miter gauge

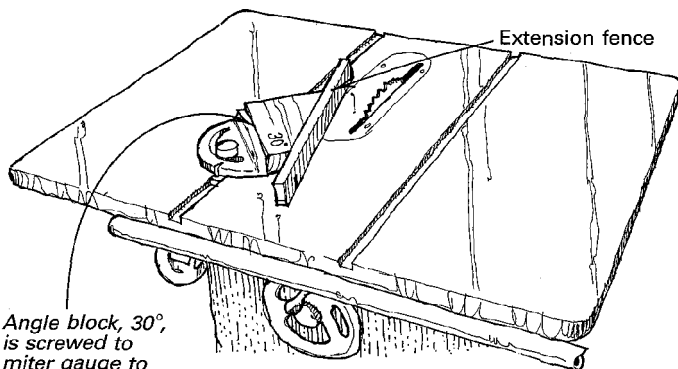

Angle block, 30°, is screwed to miter gauge to increase its range of angles.

Some of my projects require cuts at 12° or 15°, but my tablesaw's miter gauge is limited to 30° to the left or right of the 90° setting.

To expand its range, I made an adapter, shown in the drawing below, left, that I screw to the face of the miter gauge. The adapter is a 2-in.-thick block of wood cut at 30°, which allows me to make acute angle cuts down to 0°. The block can be reversed on the gauge for use in the right-hand miter-gauge slot. Adding an extension fence to the block is also helpful in many situations and lets you hold long workpieces so your fingers aren't near the blade. But don't attempt to hold small pieces with your hand while cutting steep acute angles.

—Kenneth Wolfe, Wausaukee, Wis.

Quick tip: To ensure green wood doesn't crack or check before you get it on the lathe, keep it submerged in a tub of water. It can be preserved this way almost indefinitely.

—Earl Rice, Augusta, Ga.

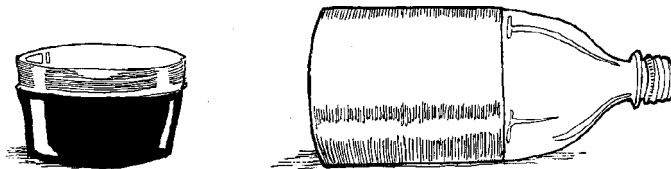

Quick tip: The cut-off bottom of a two-liter, plastic, soft-drink bottle makes a perfect mixing bowl for plastic-resin glue and similar compounds. Hardened glue will not stick to the flexible bowl.

—R.S. Kjarval, Chicago, Ill.

Methods of Work buys readers' tips, jigs and tricks. Send details, sketches (we'll redraw them) and photos to *Methods*, Fine Woodworking, Box 5506, Newtown, Conn. 06470-5506. We'll return only those contributions that include an SASE.

Mitering veneer edge strips

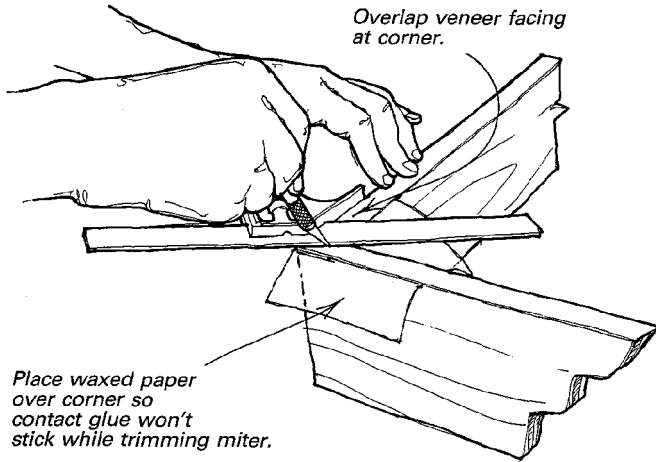

Here's how to neatly miter veneer edge strips at the corners of a carcass. First cut the strips long enough to overlap at each corner, and then apply contact cement to both the case edges and the back of the strips. Before cementing the strips in place, put a small piece of waxed paper over the corners, extending it about 3 in. along each edge. Now you can cement the strips in place, except at the corners where the waxed paper prevents the contact cement from sticking. To miter the corners, place a combination square across the corner and make a neat 45° cut with an X-Acto knife through both strips at once. Remove the waxed paper and push the strips down for a perfect joint.

—Dallas Williams, Los Angeles, Cal.

Quick tip: Use a Teflon-coated non-stick kitchen pan to hold your contact cement. Any residual cement that remains in the pan will easily peel out after it hardens, leaving a clean pan for the next job.

—Ken Carr, Jersey City, N.J.

Bandsawing waney-edge bowl blanks

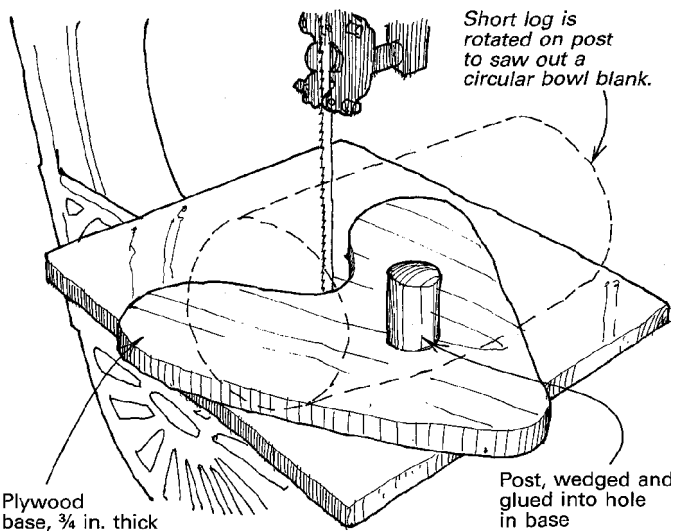

Bandsawing a short section of log into a rough circular blank for turning is a hazardous endeavor. Because the log is unstable, the blade tends to grab, increasing the possibility of it breaking or causing injury to the operator's hands. The system I suggest is considerably safer and particularly useful for those turners who use a pin chuck drive because the blank is ready to mount on the chuck right after it's cut.

The drawing (below, left) shows the details of the fixture. It consists of a 3/4-in. plywood base and a turned post that is tenoned, wedged and glued to the base. The post should be sized to fit your pin chuck. The cutout in the base allows the fixture to be pushed close to the blade for sawing out small bowl blanks.

To use the fixture, drill a hole in the log and mount it on the post. Place the fixture on the bandsaw table with the side of the log against the side of the blade (see the drawing), and clamp the base of the fixture to the saw table. Then, just rotate the log on the post to cut a circular blank.

—A. D. Goode, Sapphire, N.S.W, Australia

Quick tip: To clear dust from a face shield, use anti-static papers that have gone through the clothes dryer.

—Orv Dunlap, Phoenix, Ariz.

Carrying lumber by car

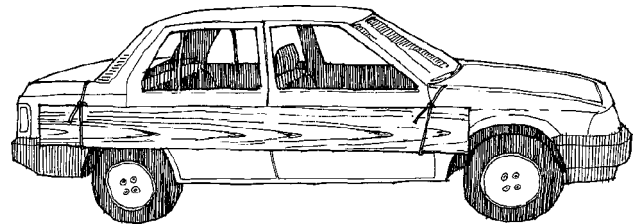

Here's an easy way to carry long boards by car that's an improvement over the usual method of balancing the lumber atop the roof and tying ropes everywhere. Plus, the loading is easily done by one person and the lumber won't shift or impair the driver's vision.

Before leaving home, I secure short lengths of rope to suitable structural members inside the trunk and under the hood. At the lumberyard, I simply tie one end of the lumber at a time to the ropes. Protect your car's paint by using towels or foam sections at the contact points.

—Don Rosati, Boston, Conn.

Cutting half-blind dovetail pins

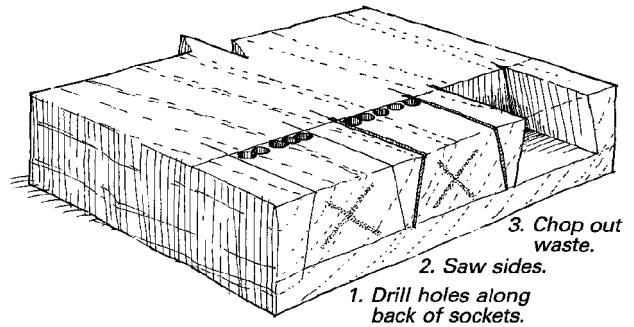

I've seen lots of how-to descriptions for cutting half-blind dovetail pins, but none has included the technique of drilling holes along the back edge of the waste. By doing so, I can chop out the pins cleaner and faster than with any other method I've tried.

After marking out the pins, use a 1/4-in. brad point or Forstner bit to drill several side-by-side holes just inside the line to be chopped away. Use a drill press if you have one, and set the depth stop so that the holes go just to the bottom of the waste section. Next, diagonally saw as much of the pin as you can, extending the sawcut slightly past the line at the back edge of the waste. Now you can easily and quickly chop out the waste with your chisel, and the flat-bottom holes provide a point of reference as you pare the bottom of the dovetail sockets.

—John Toffalelli, Durham, N.C.

Quick tip: If you don't have a compressor and need to clear chips and sawdust out of mortises and holes, keep a short piece

of flexible tubing on hand. Put one end into the hole or mortise and blow into the other end. I use an 18-in.-long piece of clean, unused auto fuel hose.

—Tony Konovaloff, Tahoe Paradise, Col.

Glue pot heater

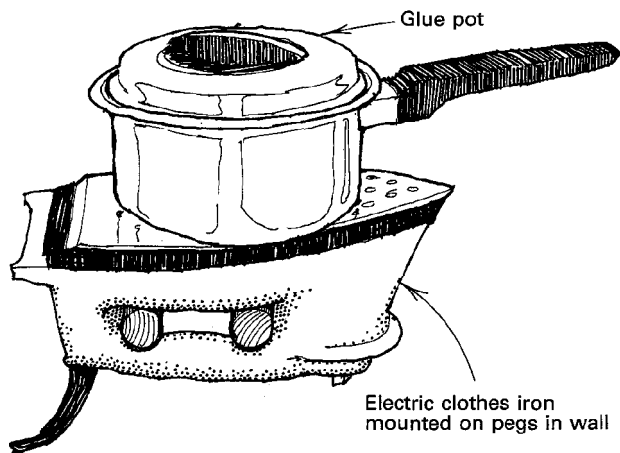

While visiting local furniture refinisher Charles Baird, I noticed his novel method of heating a glue pot. He had mounted a common electric iron upside down on a couple of pegs that protruded from the wall, as shown in the drawing above. The glue pot, which sat on the iron's flat surface, was kept at a low, even temperature thanks to the iron's thermostatic control.

—N. Clarke, Victoria, B.C., Canada

Quick tip: Chainsaw bar oil is the ideal lubricant for moving parts on woodworking tools, such as threads, gears, pivots, bearings, etc. This fine, sticky, non-spreading oil will not be quickly "wicked" off by sawdust as will regular motor oil.

—Tim Hanson, Indianapolis, Ind.

Turning candlesticks

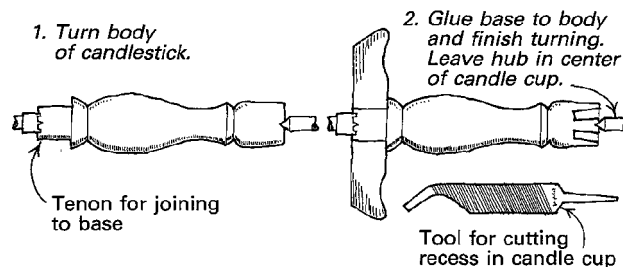

After turning hundreds of candlesticks, I've developed a method that makes production quick and easy. The big advantage of my method is that you can return the holder to the lathe and spin it between centers at any stage of production—turning, sanding, staining, finishing or polishing.

I begin by turning the body of the candlestick to shape and include a tenon on the headstock end for joining the body to the base. I make the tenon $1\frac{1}{4}$ in. dia because that size will clear the drive spur and it matches a standard drill bit size. Before removing the body from the lathe, I recess the tailstock end for a candle, leaving a small hub for the tailstock center, as shown. I made a special hooked tool from an old file for recessing the candle cup.

Then I select the wood for the base, center drill it with a

1¼-in.-dia. bit and glue the base to the body. After the glue sets, I remount the candlestick between centers while I turn the base and then sand, finish and polish the entire unit. I leave the hub in the center of the candle cup until I'm ready to sell the piece, in case I want to repolish it.

—Robert Long, Cardington, Ohio

Quick tip: To stop glue-covered parts from squirming out of alignment during clamp-up, sprinkle just a bit of sandpaper grit onto the wet glue before assembly. You'll want to keep the grit at the center of the joint where your edge tools won't find it later.

—Steve Becker, Valatie, NY.

Bending shoe molding

Tape holds wood in compression, allowing a tighter bend.

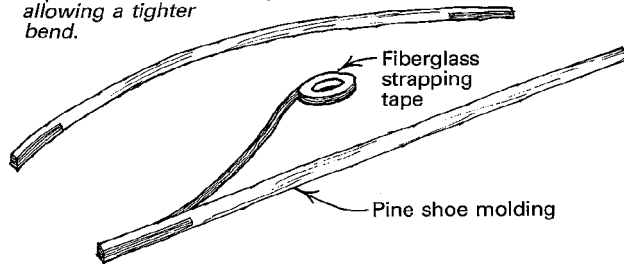

If you've ever stood in line at the lumberyard on a Sunday afternoon, then you know my despair when I was faced with yet another trip. Piece after piece of ¾-in. white pine shoe molding had snapped in two as I tried to install them in a bay window alcove. It was only a gentle 8-ft. radius, but three pieces, includ-

ing the moldy waterlogged piece I rescued from the floor of the shed, broke as I pushed them into place. With only one piece left, I finally succumbed to the reality that an 8-ft. radius is too sharp for bending kiln-dried pine.

So I considered my options. If I soaked the piece overnight, it would surely be pliable enough to take the bend, but I had other things to do the next day and besides it would take several weeks to dry out enough to paint. So I ruled that option out. I could kerf-bend it by making a series of sawcuts about 1 in. apart. But all I had was a portable circular saw and I couldn't quite see making a zillion cuts in the face of the molding without a ridiculous amount of tearout. And every one of those cuts would have to be filled.

Then I thought of steam bending with a back strap and end blocks. Wood compresses 10 times more than it stretches. A back strap on the outside of a bend takes up all the tension and forces virtually all the wood into compression. But I wondered how to get a steel back strap behind a piece of molding, nail it home and retrieve the strap.

Then it hit me. Don't use steel, but instead use a material with a high tensile strength that can be left on the molding and nailed to the wall. So I ran for my roll of fiberglass-reinforced strapping tape. This tape is amazingly strong, expendable and nailable.

I carefully ran a strip of tape on the back side of the molding, pressing it firmly into place and making sure it wouldn't be visible at the top of the molding. At the ends, I wrapped an extra foot of tape around the front, hoping the wraparounds would act like rudimentary end blocks and force the wood into compression just as end blocks do in steam bending.

With hope springing eternal, I slowly forced the molding into the alcove, expecting any second to hear the snap that would

send me cursing to the lumberyard. But it didn't snap. The tape held; its adhesive was sticky enough, and the fiberglass reinforcement was strong enough to absorb all the tension and force the pine into compression. With nary a creak, I sprung the molding into the curve and nailed it home. I trimmed the tape from the ends and within minutes the molding had its coat of paint.

—*Christopher Murray, Baltimore, Md.*

Quick tip: Instead of fumbling around trying to grasp small nails like those used to attach sawtooth picture-frame hangers, I just slip a round bar magnet into my drill-press chuck and use the quill to push the nail home.

—*Rolf Tiedemann, Rochester, N.Y.*

Wing nut replacement #1

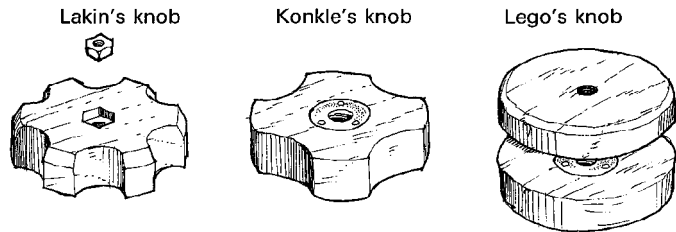

Here's a wooden knob that is a dressier alternative to Gordon Su's wing nut replacement (*FWW* #79, p. 14). With a compass set to a 1-in. radius, draw a 2-in.-dia. circle. Using the same compass setting, divide the circle into six equal parts and drill $\frac{3}{4}$ -in.-dia. holes at each of the six points. Now drill a shallow hole in the center of the original circle, using a bit with a diame-

ter equal to the smallest measurement across the hex nut that will be embedded in the knob ($\frac{1}{16}$ in. dia. for a $\frac{3}{8}$ -in. nut). Drill this hole deep enough for the nut to set flush with the knob's surface, and then chisel the hole to a hexagon shape so that the nut will fit tightly into it. Drill a hole the diameter of the bolt the rest of the way through the knob's center. Now bandsaw the knob free by following the original circle line, sand and bevel the outside edges, and press the nut into its recess.

—*Chuck Lakin, Waterville, Maine*

Wing nut replacement #2

I recess a T-nut into the top of my wooden hand knobs and fasten it in place with three brass brads. If I need clearance between the knob and whatever it will be up against, I glue a short length of large-diameter dowel to the bottom of the knob before I drill out the center.

—*Joseph E. Konkle, South Bend, Ind.*

Wing nut replacement #3

I use a T-nut sandwich in place of a wing nut. These wood knobs are not only more attractive, but let you apply plenty of torque comfortably. Before cutting out the sandwich halves with a hole saw, I drill a recess for the T-nut in the center of what will be the bottom half. I also drill little holes in the perimeter of the recess to accept the T-nut's spurs so I have a tap-in fit, not a disc-cracking, maul-in fit. After gluing the two parts of the sandwich together, I thread a bolt into the hole, chuck the thread end of the bolt into a drill and sand the knob until it is rounded and pleasant to the touch.

—*William D. Lego, Rockford, Ill.*

Quick tip: Use chunks of high-density foam, the kind made for upholstered furniture cushions, to quickly and evenly apply

any type of oil finish. Buy 4-in.-thick pieces of foam and cut the applicators to the desired shape on your bandsaw.

—R. Charles Boelkins, Conyers, Ga.

Secret drawer latch

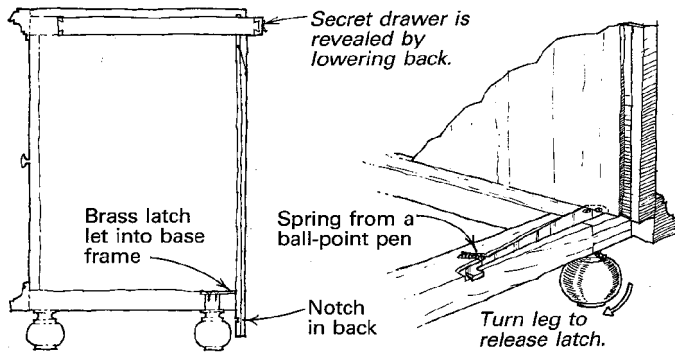

As a gift for my daughter, I recently built a scaled-down version of Alex Krutsky's spice box (*FWW* #72, p. 76). Krutsky's box features a secret drawer that is accessed by sliding the back of the box down. But a not-so-secret catch on the bottom of the box holds the back in place. I redesigned this catch so it's better hidden.

The release mechanism for the back of my box is completely enclosed, as shown in the sketch above, and it is triggered by turning the left rear leg clockwise about one-eighth of a turn. When the leg is turned, a brass latch attached to the leg's tenon rotates out of a notch in the sliding back, allowing the back to drop and therefore providing access to the hidden drawer. A spring from a retractable ball-point pen helps hold the latch in its "locked" position

when the back is up. I chose the left rear leg for the catch because it is the least likely to be tampered with by a right-handed person.

This project stirred up a lot of interest in the workshop at the retirement community where I live. Before I sent the box, I placed a few pennies in the secret drawer and I didn't tell my daughter about the hidden latch. My pleasure in completing the project was tripled when she called after spending a lot of time trying to locate the noisy coins. She was quite ready for me to divulge the secret. —G.E. Van Wynen, Sun City Center, Fla.

Miter gauge rail trick

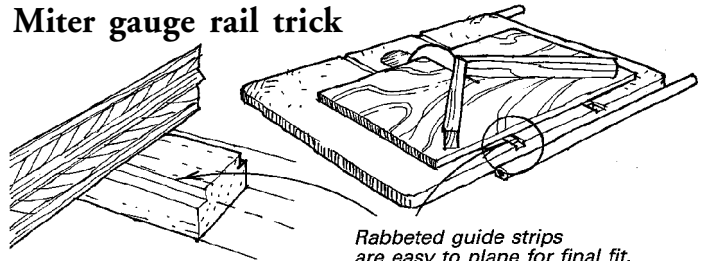

The next time you build a tablesaw fixture fitted with wood guide strips that run in the miter-gauge slots, cut small rabbets in the top edges of the guides. The rabbets not only eliminate glue clean up, but they also make final fitting easier because you can handplane the edges of the strips without having to dig into hard-to-reach inside corners. —Tim Rodeghier, Three Oaks, Mich.

Methods of Work buys readers' tips, jigs and tricks. Send details, sketches (we'll redraw them) and photos to *Methods*, Fine Woodworking, Box 5506, Newtown, Conn. 06470-5506. We'll return only those contributions that include an SASE.

Wireless vacuum switch

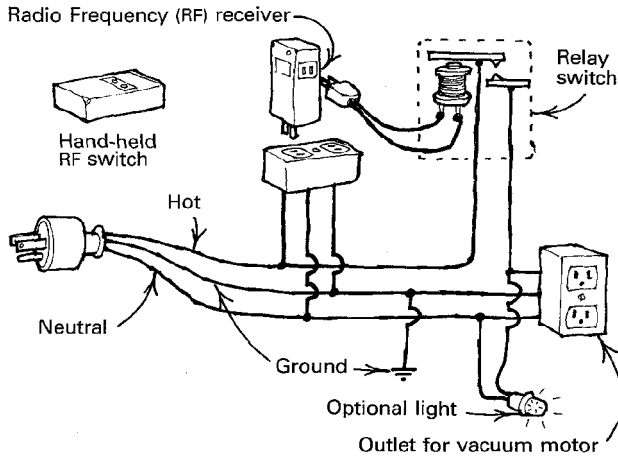

In articles about dust-collection systems, several workers have proposed some rather complicated methods using reconstructed transformers and bell-wire switches for turning the vacuum unit on and off. I've developed a simpler approach based on a device constructed from stock parts, and which has worked well in my shop. It combines a power relay with a wireless radio frequency (RF) switch to supply power to the vacuum motor. The power relay is a Potter & Brumfield 25-amp model with a 120v rated coil (#PR1AY-120 VAC. SPST N.O. from H&R Corp., 401 E. Erie Ave., Philadelphia, Pa. 19124-1187, catalog #TM25K042). The wireless RF switch (#61-2667) is from Radio Shack.

The simple schematic shows how I wired the relay. Please note that this wiring approach is fine for 120v motors, but won't work with 240v motors. The RF switch can be used by itself to control motors up to 1/3 HP, but I used the relay because the 1-HP motor on my vacuum draws up to 20 amps at start-up, which is too much current for the RF switch alone. I keep the RF controller in the pocket of my shop apron and turn the vacuum on and off while standing at the particular shop machine in use at the moment. I can keep one hand on the workpiece while operating the switch; moreover, I avoid a great deal of walking to and from the dust collector. —Peter Lofi, Rochester, N.Y.

Quick tip: Fit an inexpensive rubber crutch bottom on your hammer to knock apart antiques or assemble new cabinets without damage. —Adam Lempel, Chesterfield, N.H.

Radial-arm saw picture-frame miters

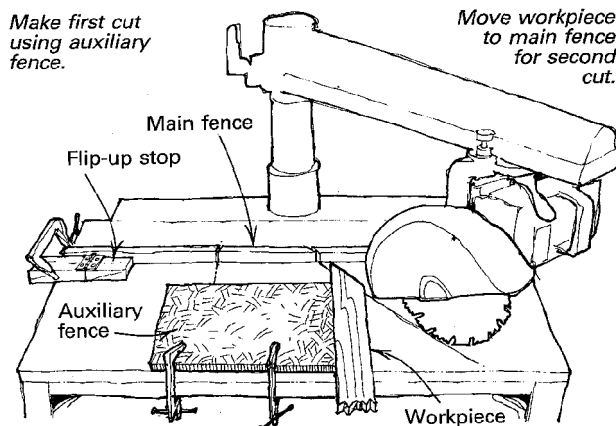

Anyone who has attempted to make picture frames with a radial-arm saw knows how difficult and frustrating it is to set the arm to a perfect 45° angle. I developed a technique that allows you to pro-

duce perfect miters by canceling out error in the saw-arm setting.

Start by swinging the arm to 45°, as determined by the built-in stop, and locking the arm in place. Now clamp an auxiliary fence to the table at a right angle to the main fence, as shown in the sketch. I use a Masonite scrap with a straight factory edge for the auxiliary fence and align it with a large framing square.

Working with a long piece of molding stock, start the frame-cutting sequence by holding the outer edge of the molding against the auxiliary fence and trimming its end to a 45° angle. Next, hold the molding's inside edge against the saw's main fence and cut the first frame section to length. Now repeat this sequence; first trim the molding to 45° on the auxiliary fence and then move it to the main fence for the second 45° cut. The auxiliary fence is used only for trim cuts on the end of the workpiece, but the main fence is always used for cutting the frame sections to length. The saw arm never moves. By cutting in this sequence, each miter cut on the auxiliary fence will complement the adjacent miter cut on the main fence, producing four perfect 90° joints.

To ensure precise, reproducible lengths, I made an adjustable stop by screwing two boards to a hinge. The length of the flip-up board is the difference between the long and short sides of the frame. When clamped to the main fence, I can flip the stop up or down to gauge the length of a long or a short side.

—Stephen R. Springston, Upton, N.Y.

Quick tip: 3M's no. 2 Feathering Disk Adhesive, available from auto-supply stores, works great for fastening sandpaper to sanding blocks, orbital sanders or rubber sanding discs. One application will last through several pieces of sandpaper.

—Carl L. Roehl, Appleton, Wisc.

Holding round tapered work

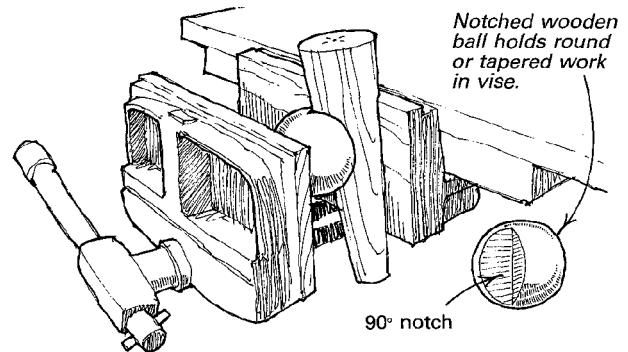

To hold round tapered work, such as a table leg, in your bench vise, cut a 90° notch in a wooden ball, as shown in the sketch. The ball, which I bought from a hobby shop, applies even pressure to the leg and holds it securely. —Albert T. Pippi, Baltimore, Md.

Repairing cracks with hydraulic injection

Fill hole with epoxy and push dowel into hole to force epoxy into crack.

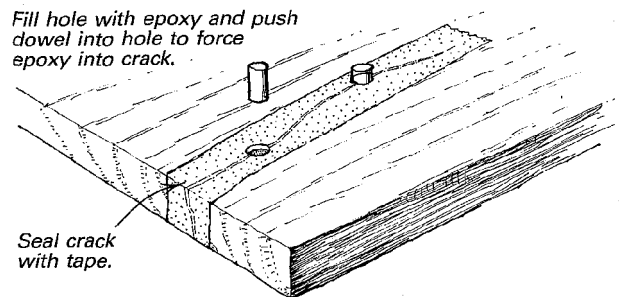

I borrowed the idea of using hydraulic pressure to force glue into a crack being repaired from a concrete firm that was do-

ing some restoration work on a concrete pier. The basic method involves drilling holes along the crack partway through the workpiece from its back side, filling these holes with glue and then pressing dowels into the holes, thereby forcing the glue into the crack.

For most repairs, I drill 1/4-in.-dia. holes about halfway through the board and space them between 1/2 in. and 1 in. apart, depending on the width of the crack. Then I seal off both sides of the crack with ordinary masking tape and cut the tape away to expose the holes. Although almost any type of glue will work, I like to make these repairs with five-minute epoxy because it sets quickly and cures to a clear color. After mixing up a small amount of epoxy, I drip it into one of the end holes until it's almost full. I then insert a 1/4-in.-dia. dowel plug into the hole and push it down so that it acts as a piston forcing the glue to penetrate into the crack. When the epoxy starts squeezing into the next adjacent hole, I let the pressure off the first plug, add epoxy to the second hole and insert another plug. I repeat this process for all the holes. The pressure created by the plugs will move the epoxy into the smallest of voids, and the masking tape prevents the epoxy from running out of the crack. After the glue has cured, trim the plugs flush.

—Dario Brisighella, Sr., Oak Creek, Wisc.

Quick tip: To make a strainer for varnish or lacquer, you'll need a coffee can that has a plastic lid. Cut the middle out of the lid, leaving a 3/8-in. perimeter, and place cheesecloth over the top of the can. The cloth is easily secured by replacing the cut-out lid. Now, liquid you pour from the coffee can will be strained as you pour it into another container.

—H. J. Patterson, Reedsport, Oreg.

Cutting precise miters

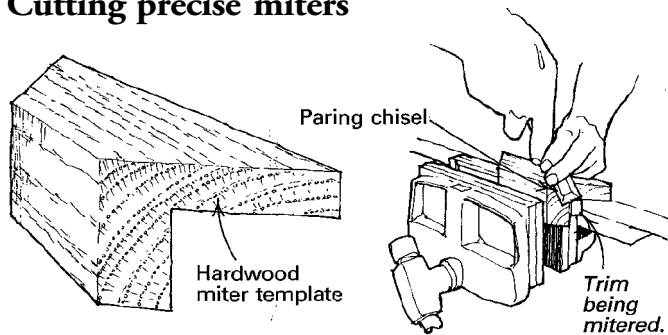

I found Mac Campbell's article, "Barred-Glass Doors," FWW#72, most informative, and I would like to offer a suggestion for cutting precise miters on small-scale stock to augment the methods presented in Campbell's article. I use a miter template as a guide for a paring chisel. I make the template by rabbeting a solid hardwood block into an L-shape and then by cutting the required miter angles on its ends. The miter angles on the template must be accurate, and so you should trim them with a sharp plane and check the angle with a bevel gauge. To use the template, clamp the workpiece and the template together at one end of your vise. Then, using the template as a guide, pare away thin slivers of waste with a sharp chisel.

—Leslie G. Greenhill, McDowall, Queensland, Australia

Quick tip: Various sizes of vent stack roof flashing can be mounted on tools and used as vacuum-hose hookups for dust collection. The rubber seal designed to fit tightly around the vent pipe will hold the vacuum hose in place, yet still allow it to be quickly disconnected. Best of all, the flashing is available at most lumberyards and hardware stores.

—Kevin Surovchak, Woodstock, Ga.

Parabola marker

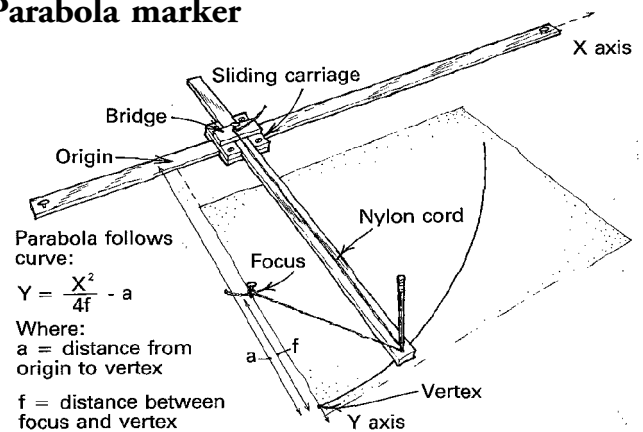

This device, which traces a portion of a parabola, is a simplified version of one developed by Terry Soper of Lockheed Engineering and Management Services Co. and published in the NASA Tech Briefs. It's just as useful for laying out parabolic shapes for boat or furniture construction as it is for designing parabolic antennae.

The marker consists of just a few parts: two tracks, a sliding carriage and a piece of nylon cord. For small parabolas, I recommend maple splints about 3/8 in. thick and 1 in. wide for the wooden parts. Make the carriage by screwing together four pieces of wood into a simple lapped frame, as shown in the sketch. You want both tracks to slide smoothly through the carriage, but to remain at right angles to each other. Attach a small wooden bridge over the top of the carriage, to anchor one end of the cord.

To use the device, first draw the Y axis, representing the parabola's centerline, and the X axis, which will be the stationary track's location. Next, locate two points along the Y axis: the focus, at the "center" of the parabola, and the vertex, at the bottom of the parabola. If you know the exact mathematical shape you want, use the formula shown to establish the focus and vertex. Or you can use trial and error to establish these points by keeping this relationship in mind: the nearer the stationary track is to the focus, the deeper the parabola; the farther away the track is from the focus, the shallower the parabola. Attach the cord to a nail driven at the focus, and then with the movable track slid up to the focus and the pencil point at the vertex, loop the cord around the pencil and back to the bridge on the carriage. The string should just be long enough to let the pencil touch the vertex. Now start sliding the carriage along the stationary track while pulling on the movable track to keep the string taut. The pencil will scribe a perfect parabola.

—Jim McGill, Seattle, Wash.

Quick tip: When tracing a pattern on dark wood, such as walnut, use a charcoal white pencil available at your local artist-supply store.

—Joseph M. Hemmann, Jefferson, Ohio

Heavy-machine shuffler

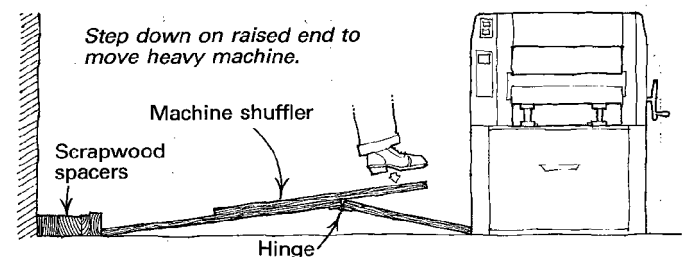

This "shuffler" is a simple device I use to move heavy woodworking machines around my workshop. With it I can shift the base of the machine 4 in. or 5 in. without rollers, wedges or back pains.

The device is made from three pieces of 1x4 scraps, joined and hinged as shown in the sketch. To use it, I place scrapwood spacers between the end of the shuffler and a convenient wall or post so that the center of the shuffler is a few inches off the floor. Then I press down on the raised end with my foot, moving the machine about an inch or so. I repeat the process, adding more spacers until the machine is where I want it. The only drawback is that if you use too many spacers, they tend to spring out. So if you've got to shift the machine more than about 6 in., just rebuild the shuffler with a longer piece of scrap. —Chris Yonge, Englewood, N.J.

Quick tip: I can't wear out T-shirts fast enough to keep up with my need for good shop rags. So I was happy to discover a source for buying cotton-knit wiping cloths in bulk. OHCO Inc., Box 1305, Covington, Ga. 30209; (404) 786-4887, sells a 50-lb. box for \$68. —R. Charles Boelkins, Conyers, Ga.

Storing electrical cords

Here's a method for storing and using long, heavy electrical cords. Drill a hole, large enough for the male end of the cord to pass through, near the base of an empty plastic bucket. I prefer 12.5-lb. Fresh Start laundry detergent buckets, but a 5-gal. paint bucket will be fine. Pass the male end through the hole from the inside and simply feed the remaining length of cord into the bucket. The cord will coil itself neatly as it falls into the bucket. Drape the female end over the side of the bucket and plug it into the male end so you don't have to fish around in the bucket for the end.

When you need to use a cord, place the bucket near the outlet, plug in the male end and simply take the female end where you need it. The cord will come out of the bucket without tangling as fast as you can pull it. —James M. Dunnam, Ft. Worth, Tex.

Quick tip: When clamping down veneer patches, I use 1-in.-thick rigid foam insulation (the kind builders use) between the veneer and the wooden cauls. It will conform to serpentine drawer fronts and can be easily cut into more elaborate shapes.

—T.A. Mickelson, Waupun, Wis.

Light-duty band clamp

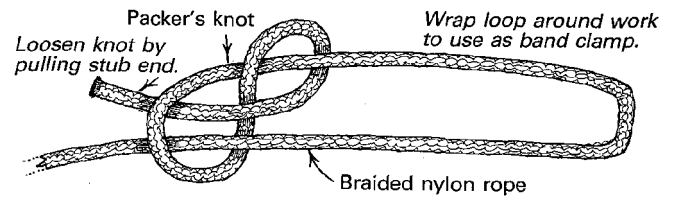

A band clamp is indispensable for assembling mitered boxes, picture frames, chair frames and the like. All you need to make a light-duty band clamp is a length of $\frac{3}{16}$ -in.-dia. braided nylon rope tied in a packer's knot. The rope is available at most hardware stores, and is cheap, strong, easy to store and won't mar the wood. The knot, illustrated above in case you've misplaced your trusty Boy Scout Handbook, will hold all the pressure you can put on it, but will loosen easily when you jerk the stub end.

Since discovering this band clamp, I've stopped using looped rubber bands and strips of inner tube, because they are more difficult to apply and store. —Robert Vaughan, Roanoke, Va.

Methods of Work buys readers' tips, jigs and tricks. Send details, sketches (we'll redraw them) and photos to Methods, Fine Woodworking, Box 5506, Newtown, Conn. 06470-5506. We'll return only those contributions that include an SASE.

Pipe clamp support leg

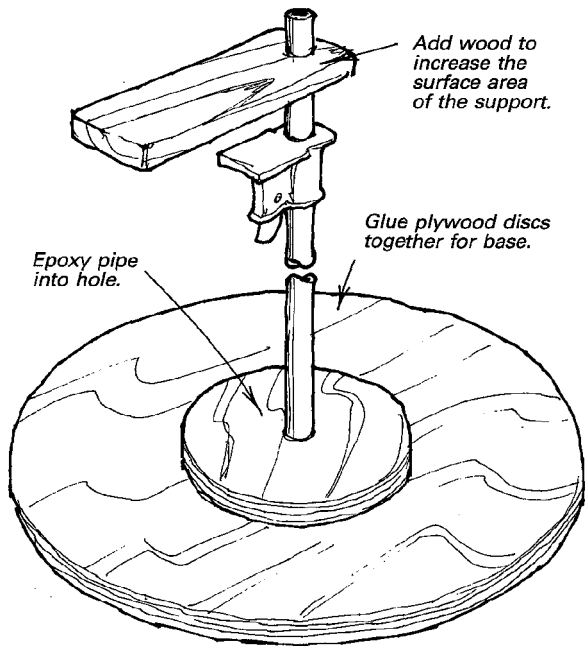

An adjustable support leg is indispensable for holding the other end of a long board you have clamped in your bench vise. Here's how to make a stable and versatile support leg using the tail stop from a $\frac{3}{4}$ -in. pipe clamp, a 3-ft. length of pipe and a plywood base. For the base, cut two $\frac{3}{4}$ -in.-thick plywood discs, one with a 5 in. dia. and the other a 15 in. dia., and then glue them together. Drill a $\frac{3}{4}$ -in.-dia. hole in the center of the 5-in. disc and epoxy the pipe in position. Now slip the tail stop onto the pipe faceup and you are ready to use the support. To increase the surface area of the tail-stop support, simply drill a pipe-size hole in one end of a plywood offcut and place it on top.

The versatility of the humble pipe clamp never ceases to amaze me. It's such a shame we can't buy them in England.
—Jack English, London, England

Ball-bearing dowel locator

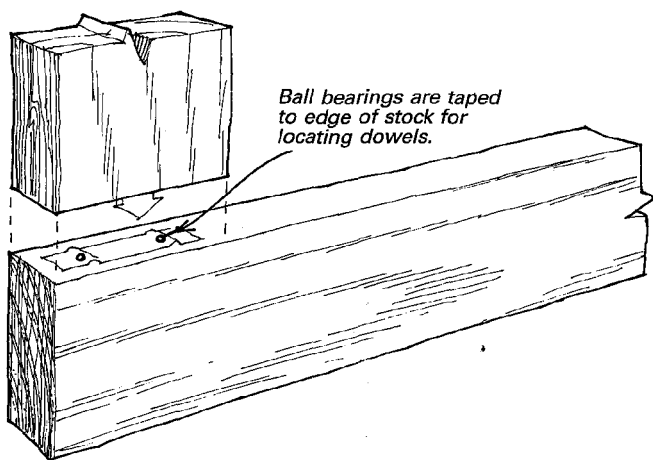

I use the small steel balls from discarded ball bearings to accurately mark the centers of mating holes for dowel joints. I just tape a pair of the small balls to one of the parts where I want the dowel holes. Then I place the other part in position and tap it with a mallet so that the balls make indentations in both pieces. Finally, I drill the dowel holes, using the indents as centers.

Steel BBs are all right to use, but they are a bit too large for fine work. I prefer $\frac{1}{16}$ -in.-dia. balls salvaged from a discarded router bit bearing or other small ball bearing. I just place the bearing in a steel vise and slowly tighten it until the outer ring of the bearing breaks. Then I scramble to retrieve at least two of the balls as they roll all over the workbench.

—Ed Moorman, Dayton, Ohio

Quick tip: Use the depression in the bottom of an aluminum soda can for mixing small amounts of epoxy, paint or glue. Make sure you clean the depression before putting the can in your recycling bin.
—Jack Howard, Auburn, Wash.

Avoiding sprayer cleanup

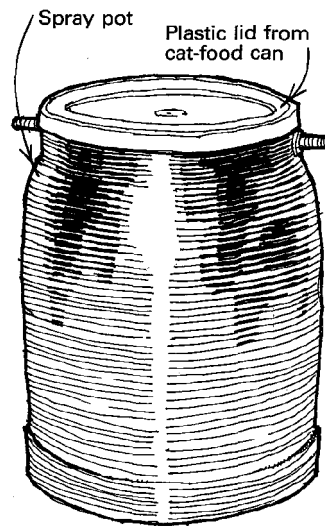

Rather than go to the time, expense and disposal problems of using solvent to clean the quart pot to my sprayer after each use, I keep lacquer in the can all the time and just add more when needed. After spraying, I remove the pot, wipe off the gun's fluid tube, and then seal the pot with an inexpensive plastic cat-food can cover (available at supermarkets). I then attach an identical spare quart pot filled with thinner and run the thinner through the gun for a few seconds to clean the inner workings. I disconnect the air hose, flip the lever release to relieve pressure,

and keep the thinner cup attached to the gun until the next time I need to use it.

—Buzz Coren, Tryon, N.C.

Making large pulleys on the tablesaw

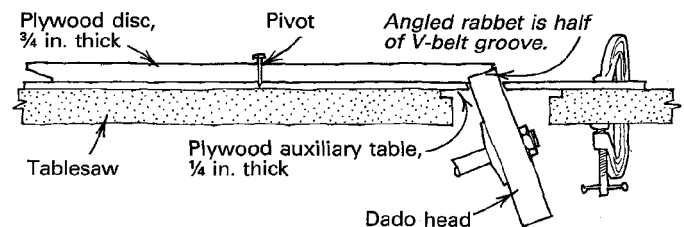

The large, slow-moving turntable I was commissioned to build as part of a stage set for my community's performing-arts center presented an interesting challenge. The 4-ft. turntable had to hold a 200-lb. actor and spin at 2 RPM. Our solution was to use a low-RPM gear-reduction electric motor further reduced by a V-belt turning a 15-in.-dia. pulley. I had no problem locating the small pulley that fit on the motor shaft. But I was unable to find a 15-in.-dia. pulley locally and did not have a lathe to turn one. However, I found another, very simple method to make the pulley.

The pulley consists of two 15-in.-dia. discs, which I bandsawed from $\frac{3}{4}$ -in.-thick plywood and screwed together. But before assembling the two discs, I used a dado head on the tablesaw to cut an angled rabbet in the edge of each disc to form the groove for the V-belt. To do this, I installed the dado head on my table-saw and tilted the arbor to the same angle as the side of the V-belt. I clamped a piece of $\frac{1}{4}$ -in.-thick plywood to the top of my saw and drilled a small pivot hole into the plywood, $7\frac{1}{2}$ in. from

the dado head and in line with the arbor. Then, with the dado blade lowered, I pushed a pin through the center hole of one of the discs and into the pivot hole in the plywood auxiliary table. Next, I turned the saw on and slowly rotated the plywood disc as I simultaneously slowly raised the dado blade. When the rabbet on the first disc was cut to the proper depth, I lowered the blade, removed the disc and repeated the process with the second disc. I then screwed the two discs together to form a strong, durable pulley with an accurate V-belt groove.

—Gene Stemmman, Corvallis, Oreg.

Angle blocks for the radial-arm saw

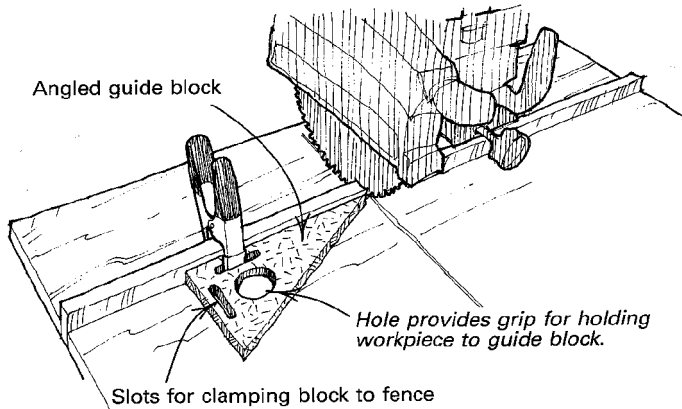

When you need to make angle cuts on a radial-arm saw, it is quicker and more accurate to use precut guide blocks than it is to move and reset the saw arm. But using an angled guide block

is safer if the block is fixed to the fence, so I rout $\frac{1}{2}$ -in.-wide slots in the block along both perpendicular edges, for securing it to the fence with a spring clamp. In addition, a large hole cut in the center of the block with a hole saw provides a convenient way to hold the work firmly to the guide block during the cut.

—James Hurley, Nevada City, Cal.

Quick tip: A spoon gouge makes a handy countersinking tool. Just push the blade into the wood at the perimeter of your clearance hole and twist your wrist. Gouge sizes for various wood screws are: 7mm for #6 to #8; 10mm for #10 to #12; and 13mm for #14.

—Michael J. Petyo, Allentown, Pa.

Hot-glue surfacing sled

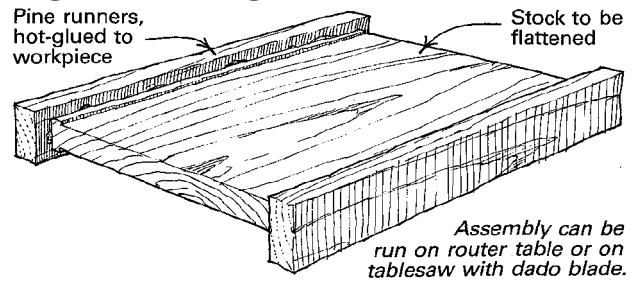

Tim Hanson's article on surfacing stock with a router (*FWW* #77) brought to mind a quick surfacing method I conceived to salvage a badly misshapen piece of beautifully figured walnut that I wanted to use for a cribbage board.

I first jointed the two long edges of the warped walnut and then fastened two pieces of scrap pine to these edges with hot-melt

glue, thereby creating a sled with the walnut centered between the two pine runners. To make sure the assembly was square, I held the three pieces together against the fence and top of my tablesaw while the glue set. The hot glue is strong enough to hold the sled together during milling, sets up in minutes and enables easy disassembly when the operation is finished.

I used the sled to flatten the walnut by running it on a router table, but it would work just as well on a tablesaw fitted with a dado blade or molding head. With each fence setting, I made four passes by turning the sled over and swapping it end for end.

—Tom Rose, Los Angeles, Cal.

Quick tip: The simplest method of preventing paint skinning is to store the can upside down. —E.W Hunt, Sheffield, U.K.

Fitting complex countertops

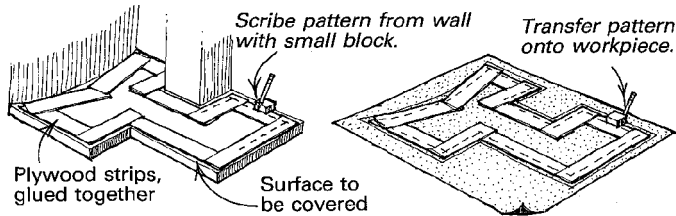

After reading about Lynn Mickelson's spiling technique (*FWW* #81, p. 18) for producing patterns, I decided to share my foolproof method for producing a complicated plywood (or laminate) countertop that must fit perfectly. As a countertop installer, I have used this method for years with excellent results.

First, arrange 4-in.-wide strips of $\frac{1}{8}$ -in.-thick plywood around

the edge of the area the top must fit, as shown in the drawing, and glue the strips together with hot-melt glue to form a loose-fitting pattern. Then, draw an exact pattern onto the assembled strips by holding a small block of wood, about 1-in. square, against the wall and marking every inch or so. Next, remove the strip pattern, set it on the countertop workpiece and transfer the marks from the pattern to the countertop using the same block of wood. Cut out the countertop leaving the line you've just drawn. If you set your saw to cut out the countertop at a slight bevel, you will reduce the amount of sanding that's required to achieve a perfect fit. Finally, belt-sand the countertop to the line and set it in place. You'll have a perfect fit without even having to use your tape measure. This method works even if the corners are out of square and the walls are uneven or curved.

—Harold Stewart, Oxnard, Cal.

Microgrooves with masking tape

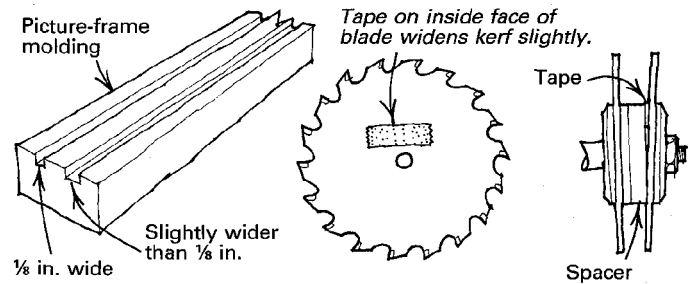

While making the picture-frame molding shown in the sketch, I found that I could cut two precise microgrooves simultaneously

by using two blades with a spacer between them. To make one of the grooves a tad wider than the normal $\frac{1}{8}$ -in. kerf, I stuck a small piece of tape on the inside face of the outboard blade to cause it to wobble slightly.

—Bryan Humphrey, Wilmington, N.C.

Hammer shield

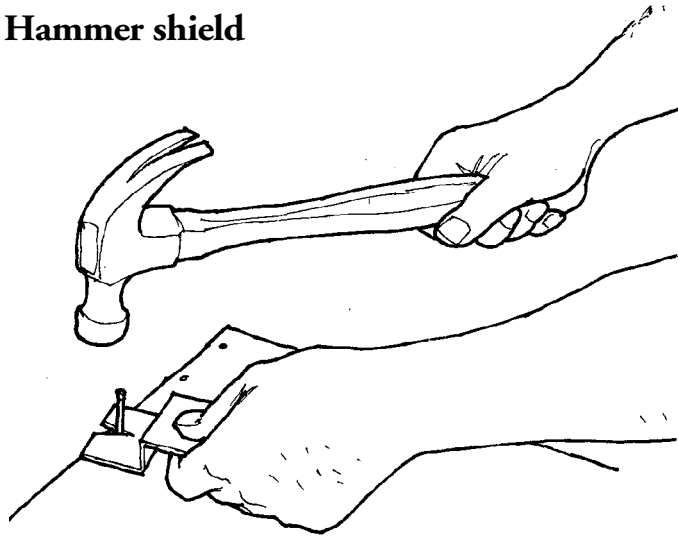

I've found that the simple hammer shield shown above is great for preventing hammer marks on special projects or woodwork. I made my shield from a small section of discarded steel strapping, which I obtained from a local lumber dealer, but any fairly heavy piece of sheet metal will work equally well. Sim-

ply cut a narrow tapered slot in one end for slipping the shield around the nail being driven, and then bend the other end up and out to form a handle. The tapered slot allows the shield to be used for almost any size nail.

—Howard E. Moody, Upper Jay, NY.

Quick tip: A safety pin clipped on your work belt or around a belt loop is handy for removing splinters.

—Peter Buchanan, Ipswich, Mass.

Clamping with styrofoam

Plywood stiffener distributes clamping pressure.

Shaped styrofoam

Workpiece

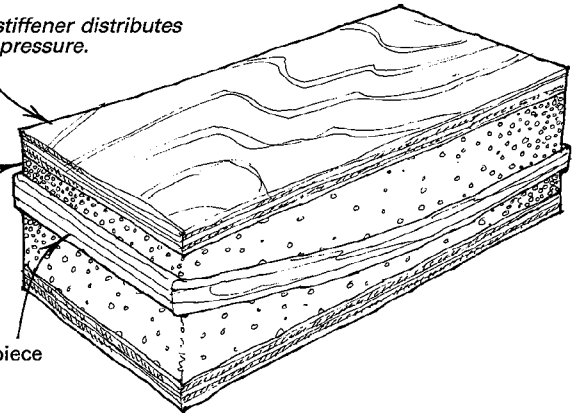

To cushion irregularly shaped workpieces for clamping or gluing, I use shaped blocks of solid styrofoam backed by plywood scraps. To make these highly effective cauls, bandsaw or carve one side of each styrofoam block to conform roughly to the contours of the

workpiece. Leave the other side of the styrofoam flat and back it with a scrap of plywood to form a rigid surface that can receive the pressure of the clamp or vise. As pressure is applied, the styrofoam compresses to the exact shape of the workpiece. After unclamping, any styrofoam adhering to glue joints can be readily brushed or scraped off. Scrap styrofoam can be scavenged from appliance packing, as well as book shipments received at bookstores or libraries. —Donald M. Carmichael, Tacoma, Wash.

Biscuit joinery on the drill press

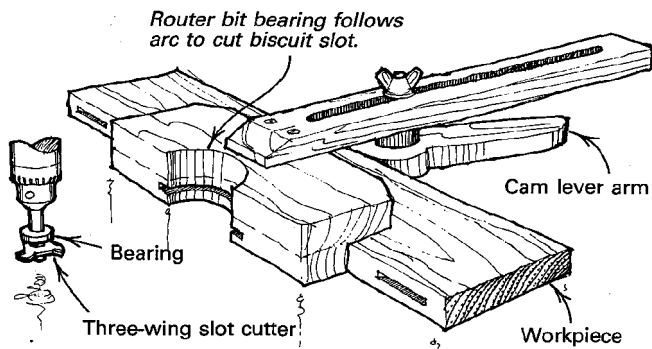

I made this fixture for my drill press to cut the slots for biscuit joints. The fixture holds the workpiece and acts as a guide for a $\frac{3}{32}$ -in.-wide three-wing slot cutter mounted in the drill press chuck. To use this method, make sure the router bit bearing is mounted above the cutter and adjust the quill so the cutter is positioned on the centerline of the workpiece. Then, place the workpiece in the fixture and tighten the wing nut on the adjust-

able cam lever arm, so the cam can be used to lock the workpiece securely into the fixture. Now, with the drill press running at its highest speed, push the assembly into the turning cutter from right to left and let the bearing follow the semicircular cut-out to rout a biscuit slot. Incidentally, this same fixture can be used on a router table if you move the bearing to the other side of the cutter.

—Ben Janney, Franklin, Ohio

Magnetic tip for a spiral screwdriver

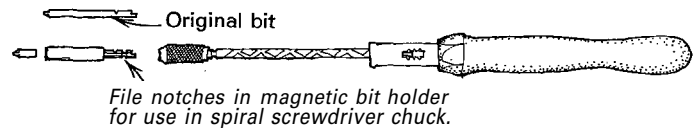

When the Phillips bit for my spiral screwdriver recently broke, I was disgusted to find that one new bit cost more than a whole packet of tips for a magnetic screwdriver bit holder. So instead I bought a magnetic bit holder and modified it to fit the spiral screwdriver. It wasn't hard. All I had to do was file notches for the drive and locking pins to correspond to those on the old bit. Now my spiral screwdriver is more useful than it has ever been. With the wide range of tips that are available for magnetic screwdrivers, I'm finding new uses every week in metalwork, as well as woodwork.

—A. Clarke, Moonta Mines, Australia

Methods of Work buys readers' tips, jigs and tricks. Send details, sketches (we'll redraw them) and photos to Methods, Fine Woodworking, Box 5506, Newtown, Conn. 06470-5506. We'll return only those contributions that include an SASE.

Drilling centered holes in spheres

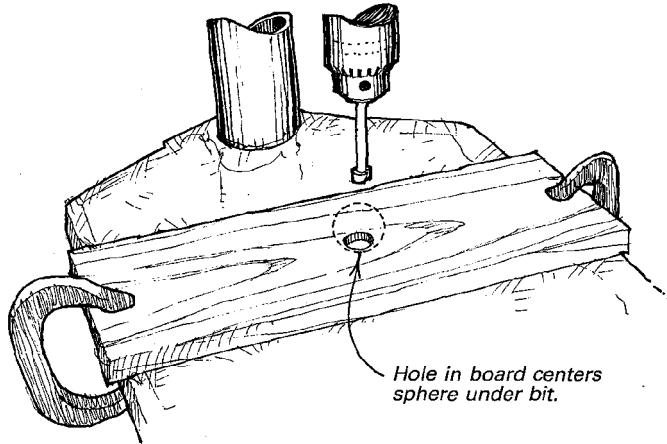

In my high-school woodshop class, we needed to drill 1/2-in.-dia. holes partway through 100 1 1/4-in.-dia. hardwood balls. I suggested to the instructor that we clamp a board to the drill press table and bore a 3/4-in.-dia. hole in the board to serve as a socket to hold the ball being drilled. Then we chucked a 1/2-in.-dia. Forstner bit into the drill press and set the stop to the desired depth. One student held each ball while another drilled. Each hole was perfectly centered. This technique worked so well that my instructor suggested that I submit it to the "Methods of Work" column. Many of the methods shared by readers of *Fine Woodworking* have been put to good use in our shop and I hope that this idea may be useful to another woodworker.

—Heather Groff, Vida, Oreg.

Quick tip: To remove oil and grease stains from woodworking projects, spray them with automobile starting fluid, which is mostly ether, and then wipe it off with a clean rag. The stains come off and the wood dries in seconds. Be sure to observe safety precautions on the can.

—George F. Bergmaier, Monroeton, Pa.

Substitute bench vise

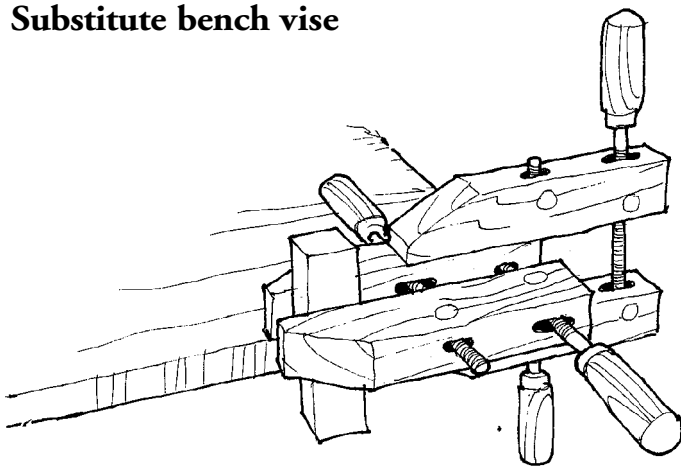

Here's a make-do vise I set up until I have the time to build a proper woodworker's bench with a built-in vise. Simply clamp one hand screw to the corner of a sturdy table with another hand screw. The bigger the hand screws the better. This temporary arrangement produces a more than satisfactory substitute bench vise. For a more permanent solution, you could secure the hand screw directly to the tabletop with a lag screw. Recently I used this setup to support doors while I planed them to final dimensions.

—Jonathan Percy, Newport, R.I.

Altering the angle of cap molding

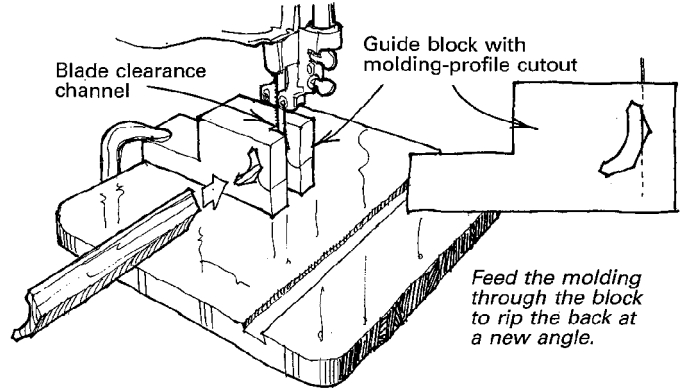

When finishing an attic (and in other situations), you may need to alter the back of cove molding to fit an angle greater than 90°. This bandsaw guide allows you to make the alteration quickly and accurately. First, cut out a guide block that can be clamped to your bandsaw table, as shown in the sketch. Then, trace the profile of your molding onto the end of the guide block and bandsaw a molding-shaped hole in the block to permit the molding to slide through with a light-friction fit. Next, cut away a sawblade clearance channel in the block.

To use the device, clamp it to your bandsaw table so that when the molding is fed through the cutout in the block, the blade will trim the back of the molding at a new angle, as shown. By tilting and shimming beneath the block, you can rip both back corners of your molding to the desired angles.

—E.G. Lincoln, Parsippany, N.J.

Quick tip: To keep soft aluminum particles from clogging your abrasive wheel, file or saw, simply spray the item with Pam no-stick cooking spray. It also prevents welding spit from sticking to a metal surface.

—Tim Hanson, Indianapolis, Ind.

Router mortising fixture revisited

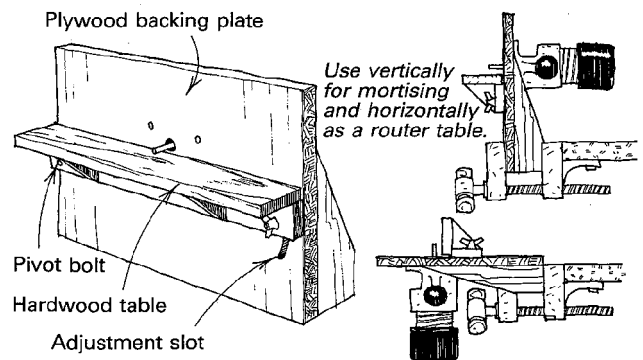

This revision of James Gier's router mortising fixture (*FWW* #78, p. 10) is made entirely from wood and so it is less expensive and it doesn't require any metal milling. In addition, the table pivots on my fixture to locate the mortise, providing an easier and more consistent adjustment than Gier's fixture, where the router pivots.

First, mount the router to a plywood or particleboard backing plate; a sink cutout from a countertop is ideal for this because it's about the right size and comes faced with plastic laminate. On the back of the plate, rout out a seat for the tool's base, leaving about 1/4 in. of material, and mount it in the seat with machine screws countersunk in the top surface. The adjustable hardwood table is attached to the backing plate with a pivot bolt

on one end and a bolt and wing nut through a slot on the other end, as shown in the sketch on the previous page. This approach allows for very fine adjustments, because when you raise or lower the end of the table, it moves only half as much under the bit.

Incidentally, you can make a fine router table by screwing a cleat to the underside of the plate so that you can hold the fixture in the vise horizontally. —*Stephen Hjembøe, St. Paul, Minn.*

Quick tip: Easy-Off oven cleaner turns redwood ebony black
—*J. Voltas, Fall River, Mass.*

Throwaway glue roller

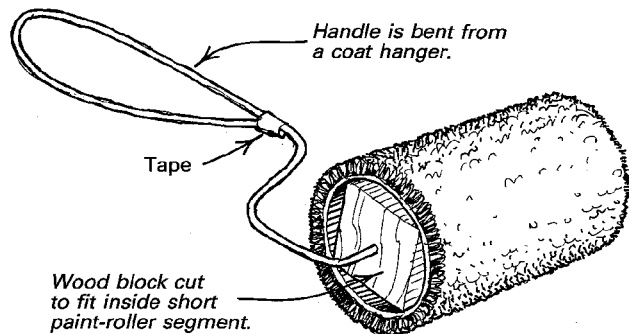

In the shop, paint rollers do a wonderful job of spreading glue, especially contact cement. But it's not long before the roller frame is ruined by adhesive buildup. So rather than purchasing and discarding roller frames at \$3 each, I make my own disposable rollers.

First, I purchase standard 9-in.-long fleece roller cylinders which I cut into quarters to give me four 2 1/4-in. lengths. Then, on the tablesaw, I rip a scrap 2x4 down to a size that will fit snugly inside the roller cylinders (about 1 1/16 in. square). I cut 2 1/4-in.-long blocks off this workpiece and center-drill one end of each block for a 7/64-in. hole. After pushing one of the blocks into one of the roller segments, I bend a coat hanger into a handle shape, as shown in the drawing, and insert it into the hole in the block. One of these handy rollers will last through most laminating jobs.
—*Lee Maughan, Panaca, Nev.*

Quick tip: If you have machines with miter gauge slots that you rarely use, such as a bandsaw, cut a filler strip and fasten it into the slot with double-faced tape. You'll find that working on a flush, smooth tabletop is easier and much more fun.

—*Richard H. Dorn, Delwein, Ia.*

Shopmade trammels for a measuring tape

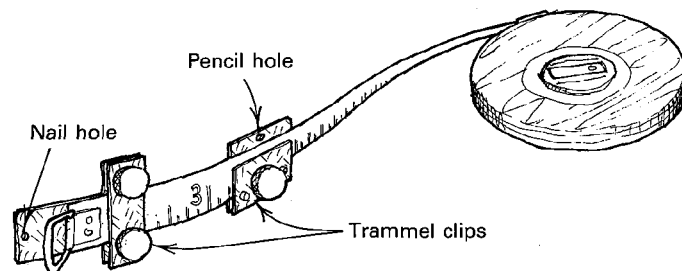

While working in the stone business for many years, I used two simple homemade clips and a metal tape measure to mark large

circles and arcs with up to a 50-ft. radius. One clip fastens near the end of the tape and has a hole for a nail. When the front edge of this clip is clamped on the 2-in. mark, the nail hole is exactly at the end of the tape. The other clip has a hole for a pencil point and can be clamped anywhere along the tape.

—Robert R. Schaefer, Maspeth, N.Y.

Quick tip: Shoe leather scraps, usually free from your neighborhood shoe-repair shop, make excellent clamp pads. Just trim them to the proper size and attach them with a dab of glue.

—Don Rosati, Boston, Conn.

Cabinet pulls from tuning pegs

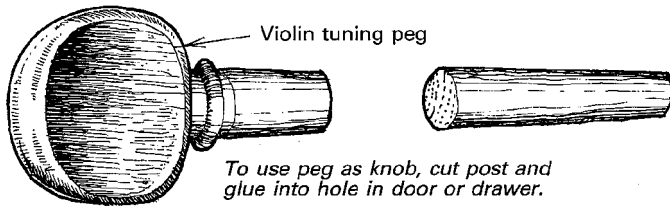

At the same time I was working on a Shaker wall cabinet I happened to stop by a music store for a set of guitar strings. While there, I noticed the violin tuning pegs for sale and decided to use one for a knob on my cabinet. Tuning pegs have several qualities that make them ideal as knobs on small cabinet doors and drawers. They are made of ebony, which contrasts well with most woods, and they are locally available at a reasonable cost. But best of all, tuning pegs are shaped and polished in such a way that they feel smooth and comfortable to the touch. To in-

stall the peg, I simply cut off all but $\frac{1}{2}$ in. of the post and glued it into a hole in the cabinet door. —John Kodis, Pasadena, Md.

Quick tip: While helping in the kitchen of a friend who owned plenty of dull knives but nary a sharpening stone, I discovered that the unglazed foot of a porcelain dish makes a serviceable whetstone. When you draw the knife across the foot, you will leave a slight mark; so avoid the heirloom china lest your resourcefulness be unappreciated.

—Gregory V. Tolman, Mammoth Lakes, Cal.

Edging plywood without clamps

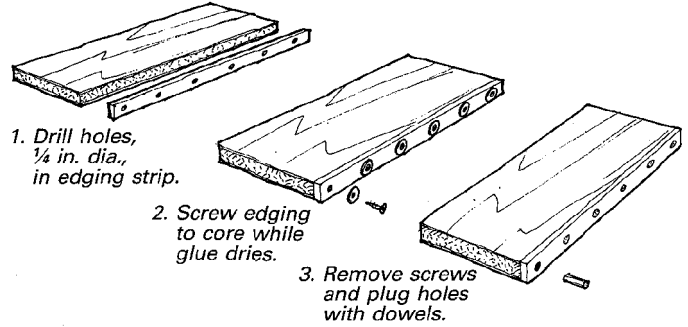

Instead of using clamps, I like to secure wooden edging strips to plywood cabinet doors with screws until the glue dries. First I drill $\frac{1}{4}$ -in.-dia. holes through the solid-wood edging strip every 4 in. along its length. I apply glue to the back of the strip, set it in place along the edge of the plywood, and immediately drive a drywall screw with a large washer through each hole into the

core material. After the glue dries, I remove the screws, drill each hole to about 1 in. deep and plug with a dowel. When the plugs are trimmed flush, they add visual interest to the edging.

—Bruce Clattenburg, Owen Sound, Ont, Canada

Furniture disassembly jack

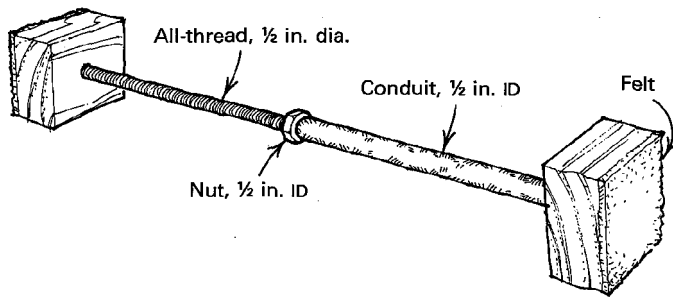

Those of us who repair furniture often come across a chair or table that is so loose it needs to be totally disassembled and reglued. But invariably there are always two or three joints that, unlike the rest of the rickety piece, will not come apart no matter what. I use a shopmade jack to solve this problem. The jack, shown in the sketch, is composed of a short length of 1/2-in. conduit, a piece of 1/2-in.-dia. all-thread, a nut and two padded blocks. When you tighten the nut against the end of the conduit, even the most reluctant joint will give up, usually with no damage.

—Lee Crowder, Boston, Md.

Quick tip: Old hard drives from personal computers contain several useful components. The bearings and spindle make a

smooth-working lazy Susan, and the platters make excellent 1/2-in.-thick spacers for a tablesaw dado blade.

—Jim Clifton, Kalamazoo, Mich.

Board-straightening fixture

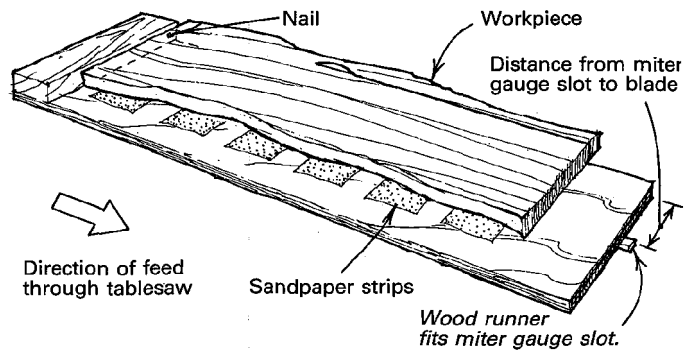

This is a great board-straightening fixture. Simply press one end of the crooked board into the nail at the head of the fixture, allowing the board to overhang the plywood base by 1/2 in. or so. Hold the board on the sandpaper strips so it won't move, and slide the whole arrangement through the tablesaw with the wood runner in the miter gauge slot. You can straighten a dozen boards in five minutes.

—Jim Puterbaugh, Portland, Oreg.

Quick tip: To reduce tearout problems, wipe down a board with a damp cloth a few minutes before passing it through the thickness planer. The water makes the fibers flexible enough so

they don't break. I've had good results with bird's-eye maple.
—Bruce Searle, Roberts Creek, B.C., Canada

Pin routing on the drill press

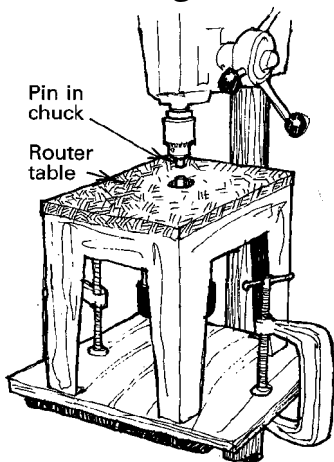

Occasionally I need a pin router, but not often enough to justify the expense or to permanently dedicate the scarce shop space in my garage. So I came up with a way to convert my drill press into an inverted pin router quickly and easily.

First, screw a rectangular particleboard base to the legs of your router table so it can be clamped to your drill press table. Mount a short length of drill rod or an inverted drill bit in the drill press chuck to act as the pin, and then lower the quill all the way and lock it. Next, lower the drill press table a couple of feet so the router table will fit between the table and the pin. Then, clamp the router table to the drill press table after you have carefully centered the router bit beneath the pin.

To use the pin router, raise the quill and place your workpiece on the router table. Then lower the quill and lock it when it is at the right height to engage the pin routing pattern.

—David Jeffrey, McKinleyville, Cal.

Cross-drilling round stock

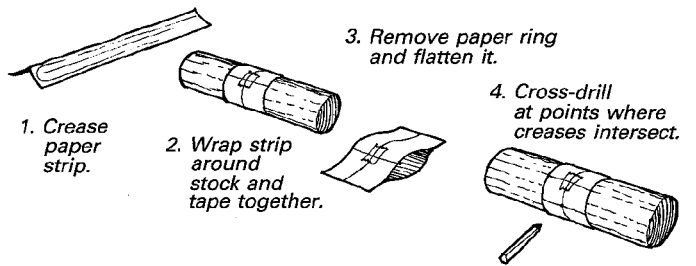

Here's a method for laying out points for cross-drilling round stock. Fold a strip of paper in half lengthwise and crease the fold with your fingernail. Unfold the strip and wrap it tightly around the stock. Align the crease at the overlap and join the strip with a piece of tape. Slip the ring off the stock and flatten it, creasing both ends with your fingernail again. These two creases will be directly opposite each other when you slip the ring back onto the stock, and therefore can be used to mark the layout points for the through hole. Use a marking punch to transfer the points to the stock. For tubular stock you can drill from both sides. With solid stock, drill a small-diameter pilot hole at each mark so they will meet in the center; then drill through with the correct size bit to remove any irregularity.

—David Jones, Victoria, B.C., Canada

Methods of Work buys readers' tips, jigs and tricks. Send details, sketches (we'll redraw them) and photos to *Methods*, Fine Woodworking, PO Box 5506, Newtown, Conn. 06470-5506. We'll return only those contributions that include an SASE.

Adjustable blade-grinding fixture

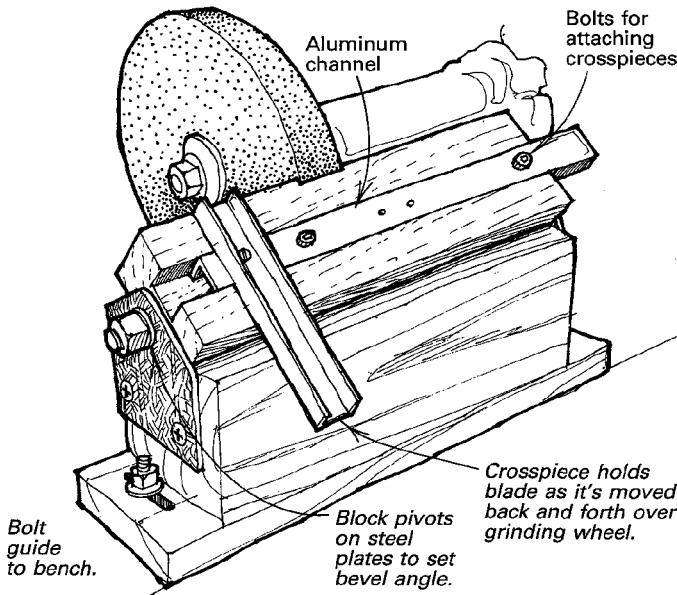

This grinding fixture is very flexible because its pivoting hardwood block lets you adjust the angle between the blade and grinding wheel, and it can handle a wide range of blade widths. The pivoting hardwood block is attached to a wood base fitted with steel end plates, as shown above. To make it, cut a slot in the top of the pivoting block to accept a length of aluminum channel. Fit this channel with various screw holes or attachments, such as the crosspiece shown, to hold each blade correctly as it's moved back and forth across the face of the grinding wheel. Wax the channel regularly to keep it running smoothly. To provide maximum support for the blade during grinding, cut out a section of the pivoting block just in front of the grinding wheel so you can move the assembly as close to the wheel as possible. — David Shackleton, White Rock, B.C., Canada

Sanding toy wheels

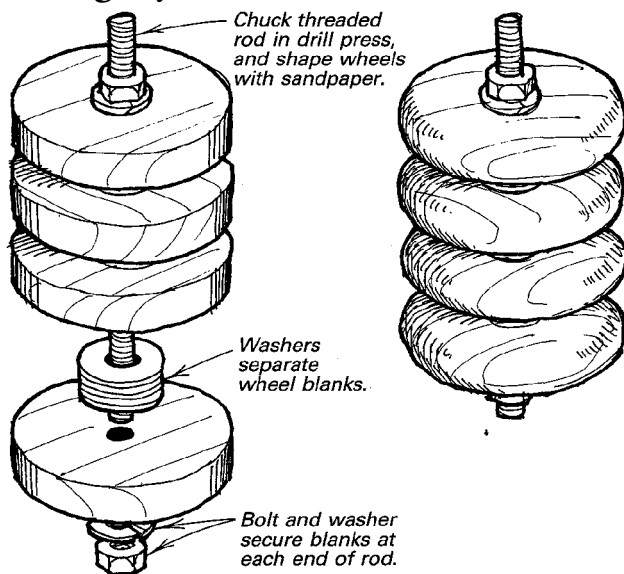

My toy vehicles are so popular with my grandchildren that I have a constant demand for wheels. I speed production by using the gang-sanding setup shown in the sketch to true the wheels and round them over in a single operation.

After roughing out the wheel blanks with a hole saw or fly-

cutter, mount the blanks on a threaded rod with four or five washers between each blank, and chuck the rod in your drill press. Use sandpaper on a block of wood to true up the diameters of the wheels. Round over each wheel's edge with hand-held sandpaper, but wear a thick leather glove to absorb the heat. —William J. Sallans, Houston, Tex.

Quick tip: "Plasti-Clear," a spray sold by marine-supply stores for cleaning plastic windshields and instrument covers, is excellent for reducing static and dust buildup on plastic face shields in the shop. —Susan S. Ellison, Oxford, Md.

Grooving dowels

Screws cut groove as dowel pin is tapped through oversize hole.

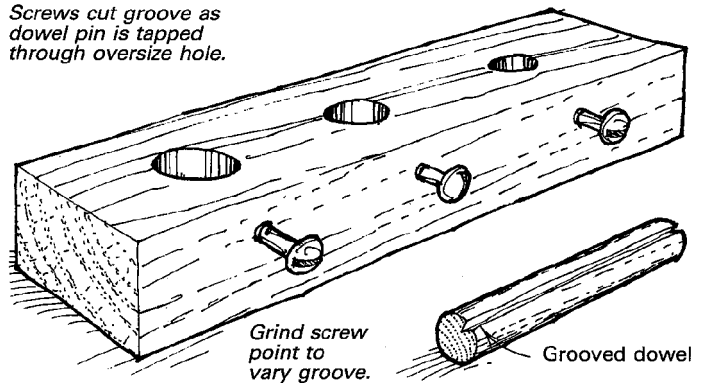

Grooved dowel pins disperse glue and hydraulic pressure in a joint better than straight pins. It's easy to groove your own dowels if you make this simple fixture. Drill a hole through a maple or oak block; the hole should be about 1/32 in. larger than the dowel being used. Then drive one or more steel screws in from the sides of the block, so that the point of each protrudes slightly into the hole. The ends of the screws may be shaped on a grinder, if you desire. To groove the dowel, tap it through the hole with a mallet. —R. Richardson, New Iberia, La.

EDITOR'S NOTE: A similar method was submitted by Donald Pelton of Colorado Springs, Colo.

Quick tip: 3M's Spray Mount adhesive, available from art-supply stores, is great for attaching sandpaper to sanding blocks and sanding discs and for tacking peel-off paper patterns right to the wood. —Robert M. Vaughn, Roanoke, Va.

Laying out a five-point star

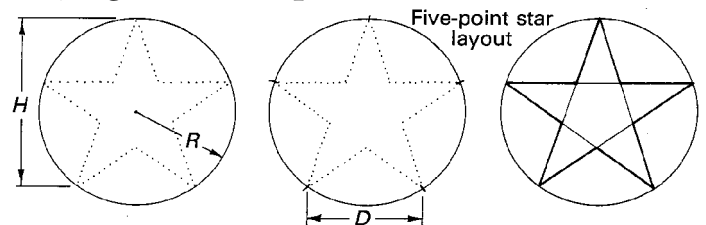

1. Calculate R and draw circle.
 $R = H \div 1.8090$

2. Calculate D and mark off points.
 $D = R \times 1.1756$

3. Draw star.

I recently needed to lay out a symmetrical five-point star. Since using a protractor can be time-consuming, I developed a quick and easy method that allows me to lay out any size star with only a compass and a calculator. To avoid strange fractions in your calculations, you should work in centimeters instead of inches.

To lay out a star of height (H), divide H by 1.8090 to find the radius (R) of the layout circle. Set your compass to R, and draw a circle. Multiply the radius distance by 1.1756 to determine the distance (D) between the points of the star. Reset your compass to D.

Now, start at the top of the circle and move from point to point, marking five equidistant points on the circumference of the circle. To complete the star, connect every other point with a straight line.

For example, if you want a star that's 10cm tall, first determine the radius of the circle using the formula H divided by 1.8090. If the height is 10, then the radius equals 5.5279.

Now, set your compass to 5.5279, and draw a circle before calculating the distance (D) between points. You can determine the distance by multiplying the radius (R) by 1.1756. In this case, D will be 6.4986. Set the compass to 6.4986 and mark out the points of the star. —Daniel V. Bass, Anaheim, Cal.

Shopmade woodworker's micrometer

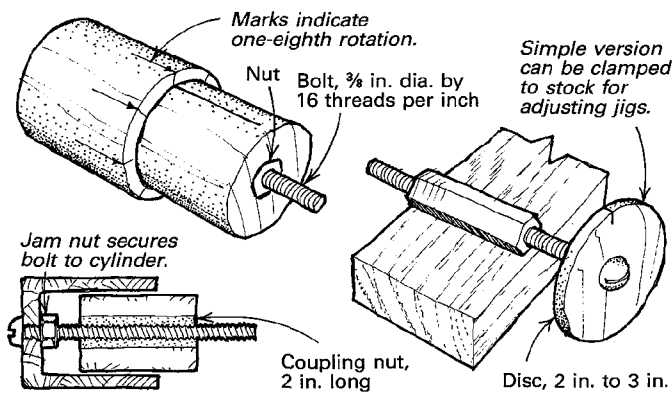

You can assemble a micrometer, accurate to within $\frac{1}{256}$ in., with a 60-cent nut and bolt from your local hardware store. Don't

believe me? If you disassemble a machinist's micrometer, you will find a 2-in.-long, 40-teeth-per-inch (t.p.i.) bolt running in a $\frac{1}{2}$ -in. matching nut.

I make my woodworker's micrometer by running an ordinary $\frac{3}{8}$ -in., 16-t.p.i. bolt in a matching 2-in.-long coupling nut. The extra threads of the long nut increase the accuracy of the unit.

Since the bolt has 16 t.p.i., its head moves $\frac{1}{16}$ in. with each revolution. Using a dial indicator to test the movement, I have consistently obtained accuracies of better than 0.0002 in 2 in. of bolt. By mounting a disc on the head of the bolt and drawing a centerline to divide the disc into halves, you can easily obtain $\frac{1}{32}$ -in. increments with the same repeatable accuracy. Divide the disc into quarters and eighths to get $\frac{1}{64}$ -in. and $\frac{1}{256}$ -in. movements. You can make a fancy micrometer, like the model shown on the left side of the sketch, or just clamp the nut, shown on the right side of the sketch, in place and rotate the head of the bolt in quarter or half revolutions with almost equal accuracy. —R. Entwistle, Winter Park, Fla.

Quick tip: Try applying wiping stain with a spray gun. It goes on faster and more uniformly, and then wipes off with fewer rags. —Robert M. Vaughn, Roanoke, Va.

Securing machines with adhesive

The usual solution for securing benches and machines is to bolt them to the workshop floor. An alternative to this is to literally glue the equipment to the floor with a high-quality panel-and-construction adhesive. After you have positioned your machines, level them with small wooden shims. Then use a caulking gun to run a bead around the base of the equipment, and smooth the bead quickly with your finger. When the adhe-

sive cures, it becomes very durable and hard. The benches won't rock when you are working, and the machines won't creep. If you decide to relocate a machine in the future, you can simply remove the adhesive with a chisel.

—Richard H. Dorn, Oelwein, Ia.

Coping molding with a router

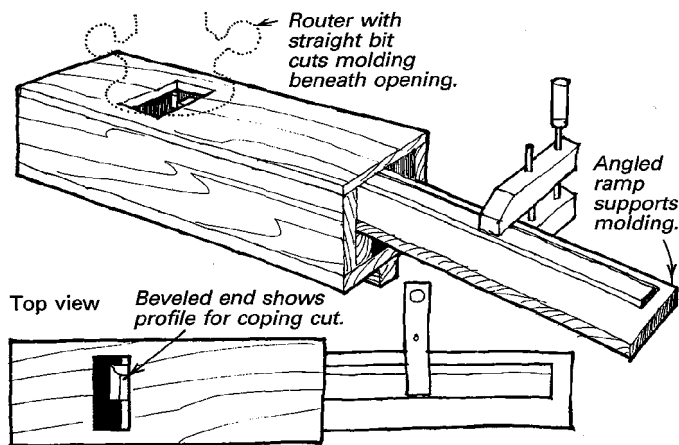

A coped joint fits and looks better than a mitered joint. So when I replaced all the base molding in my home, I decided to cope the joints at the inside corners of the rooms. Traditionally, joints are coped by first cutting a 45° miter on the end of one piece of molding and then using a coping saw to cut along the curved line created where the miter cut intersects the molding's surface. This

trims the end to the exact reverse section of the molding so that it will butt into the other piece of molding already installed tightly in the corner. Being fundamentally inept with hand tools, my attempts at sawing the joint fell far short of my expectations. Finally, I came up with the following router-based fixture, which makes this job more tolerable.

The fixture is a rectangular box with one open end, into which a wood ramp is inserted at a 20° angle. A rectangular hole is cut into the top of the box above the end of the ramp. A 2x4 attached to the bottom of the box enables the whole fixture to be clamped into a Work-Mate portable workbench.

To use the fixture, cut the end of the molding at 45° so that the profile on the end shows the area to be coped away. Alternatively, you can scribe the molding with the shape to be cut and score any straight sections with a utility knife. In either case, insert the molding into the box and clamp it onto the ramp. Chuck a 3/16-in. straight bit in a router and insert the bit through the hole in the top of the fixture. Turn on the router and follow the scribed line to cut off the end of the molding. The angle of the ramp creates a slight back cut at the shaped edge, which makes the pieces fit together better. Before unclamping the workpiece, check the fit by inserting a short piece of molding through the top. Any necessary fine adjustments can be made with a file.

Once the molding is undamped, the coped joint should fit quite well. After the first couple of tries, I became quite proficient with this system. The cuts were smooth, and the fit was better than anything I had previously achieved with a coping saw.

—Scott Ashworth, Mars, Pa.

Quick tip: I mounted electric outlets on all my stationary power tools and wired them so they are always hot. Now I not only

Methods of Work (continued)

have outlets on the walls, but throughout the shop for plugging in portable electric tools.
—Kenneth Kasal, Chelsea, Iowa

Concealing nail holes

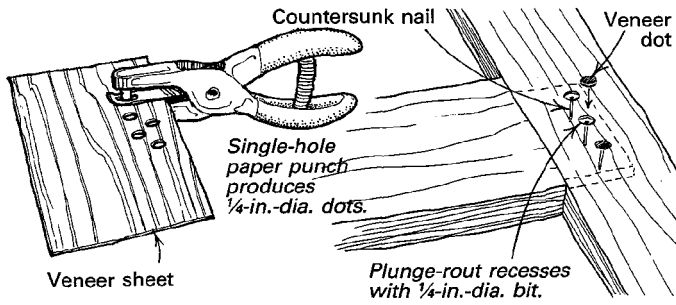

I discovered a technique for covering nail holes while rebuilding a crib for my newborn son. The side rails of the crib were fastened with mortise-and-tenon joints pinned with nails. Even though the nails were countersunk and filled, I didn't like the look.

After making several unsuccessful attempts at inlaying veneer over the nails, I remembered that a standard, hand-held paper punch, available from any office-supply store, makes a 1/4-in.-dia. hole. The tool was perfect for punching out little dots from a sheet of walnut veneer. I chucked a 1/4-in.-dia. straight bit in my plunge router, set the depth for slightly less than the veneer's thickness, and cut a clean recess over the countersunk nail. Be sure the nail is countersunk well below the depth of the hole to avoid damage or injury. The punched veneer dot snapped perfectly into the recess. If you repeat the procedure on each side of the

mortise, the joint will look as if it has been pinned through with a walnut dowel.
—David W. Kemink, AFOSI Detachment 4201

Quick tip: If you wax nails before using them, drill a small hole in the bottom of your hammer handle and fill it with molten wax. This way, the lubricant will always be handy.

—Bradley D. Hankins, Arlington, Tex.

Low-cost picture-frame hanger

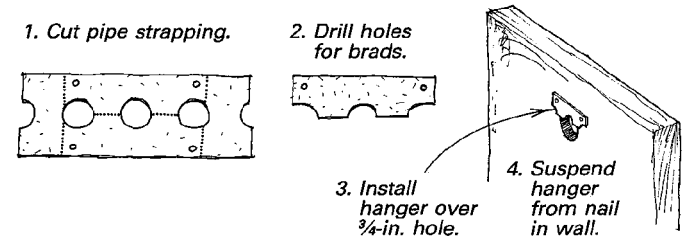

To make a quick, low-cost picture-frame hanger, use tin snips to cut a piece of metal pipe strapping, available from hardware stores, to the shape shown in the sketch. Drill a couple of small holes in the hanger so you can fasten it with brads over a 3/4-in. recess in the back of a picture frame.

—Bill Webster, Chillicothe, Ill.

Methods of Work buys readers' tips, jigs and tricks. Send details, sketches (we'll redraw them) and photos to Methods, Fine Woodworking, PO Box 5506, Newtown, Conn. 06470-5506. We'll return only those contributions that include an SASE.

Lathe-mounted drum sander

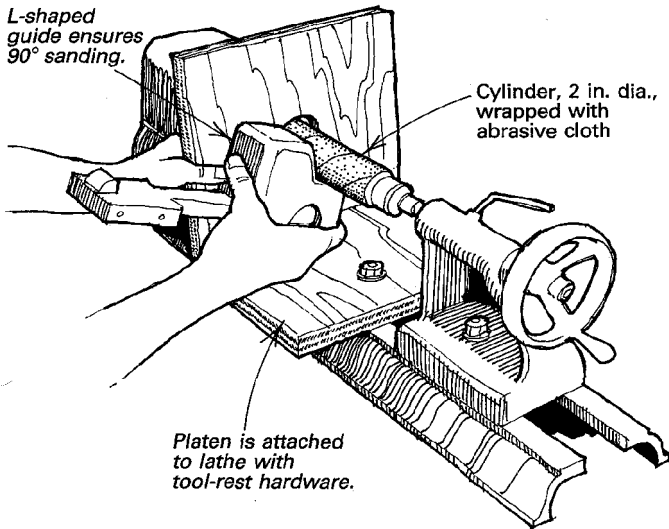

I use this drum sander on my lathe to smooth concave surfaces on the toy cars and trucks I build. The sanding drum is nothing more than a 2-in. wooden cylinder that's spiral-wrapped with coarse abrasive cloth. Since most of the sanding I do is at right angles, I built an L-shaped platen from 3/4-in. plywood; it attaches to the lathe's ways using the tool rest's hardware.

—George Clayton, Ft. Worth, Tex.

Quick tip: A penny has a diameter of 3/4 in. and is a handy reference gauge when other measuring devices are lacking.

—Robert Vaughan, Roanoke, Va.

Improved fingerboard

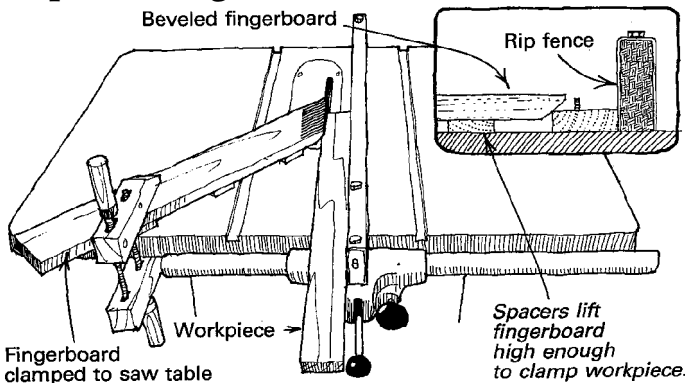

Fingerboards are great for holding boards against a fence or down on a table, but they usually can't do both jobs very well at the same time. However, if you cut a bevel on the leading edge, as shown above, the fingerboard can accomplish both tasks. Raise the fingerboard off the table with spacers to make it hit the stock at the right place.

—Richard Chiros, Marlboro, Mass.

Copying furniture carvings

Before you can copy a carving from one piece of furniture onto another, you need to transfer a pattern of the original carving to the new piece. A quick method is to cover the original carved area with overlapping strips of masking tape. Next, rub the surface of the masking tape with the broad side of the point of a soft lead pencil. High areas come out dark, low areas come out light.

Now carefully lift off the masking tape as a single sheet, and transfer it to the piece to be carved. The masking tape becomes a throwaway template to guide the carving process, thereby

eliminating a lot of tedious measuring and marking. Any tape residue remaining on the surface can be peeled off easily.

—Frank D. Hart, Plainfield, Ind.

Standing shaving horse

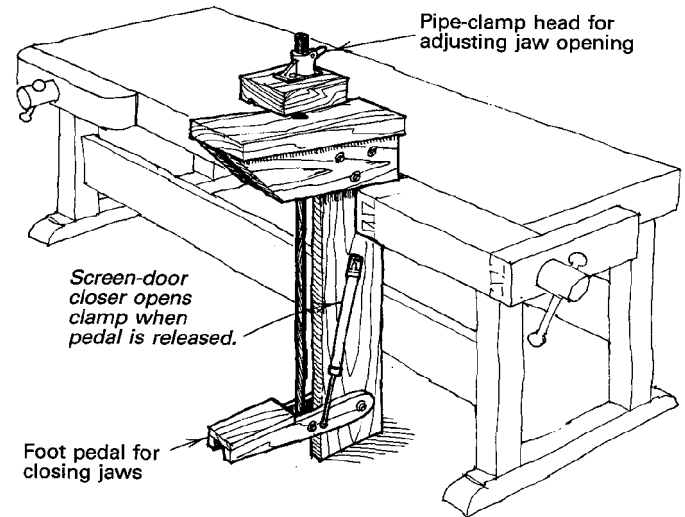

The design of the conventional shaving horse, despite its evolution over hundreds of years, has some disadvantages: the seat gets pretty uncomfortable after a time, and the horse just takes up too much space. This compact alternative, made mainly from 2x6 and 2x8 lumber, solves both problems. To make the horse, use hardwood for the clamp block and foot pedal, and yellow pine construction lumber for the frame and clamp table. Install a 4-ft. length of iron pipe between the clamp block and the foot pedal, using a pipe-clamp fixture on the top, as shown, to adjust the clamping width. A screen-door closer attached between the foot pedal and the frame will provide a strong return spring with a gentle action.

—Paul Weissman, West Redding, Conn.

Quick tip: When cleaning up a curved cut on the edge of plywood with a rasp, you can avoid tearing out the veneer by holding the rasp at both ends, 90° across the edge, and drawing it along the edge. Begin with a coarse rasp to remove a lot of stock, and then continue with finer and finer rasps or files until you can hand-sand.

—Dario Biagiarelli, Kirkville, N.Y.

Wider cuts with radial-arm saws

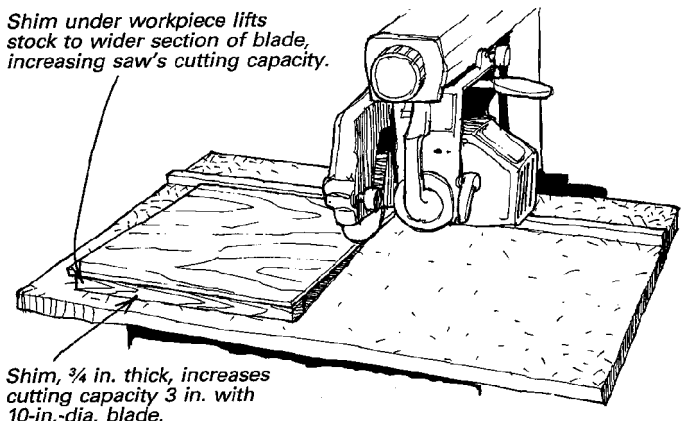

It's very frustrating to crosscut a piece of work on a radial-arm saw and find that the saw's capacity is short by an inch or two. However, there is an easy way to get an extra few inches of cut. As shown above, place a piece of scrapwood under the edge of

the work farthest from the back fence. This moves the work up into the wider part of the blade and gains you extra capacity. For example, a $\frac{3}{4}$ -in. shim will add about 3 in. to the length of cut of a 10-in. sawblade.
—Jack Jerome, Nokomis, Fla.

Binder clip cord holder

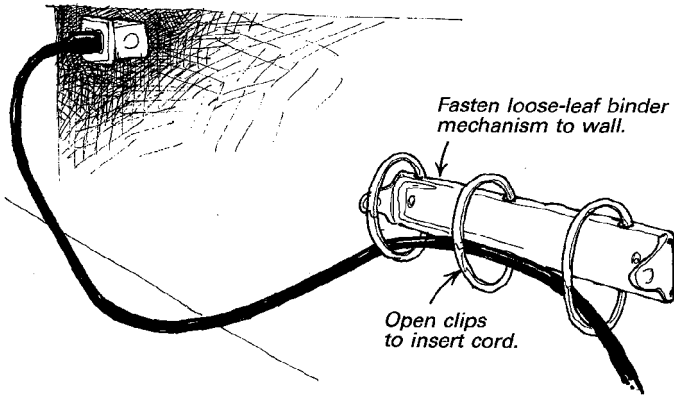

Recently I came across a simple trick to untangle the extension cords or air hoses that collect haphazardly underfoot in the shop. Salvage the mechanisms from old three-ring loose-leaf binders, and fasten them to walls, machines or benches at an appropriate height. Then, click them open and insert your extension cord as you would a sheet of paper. This setup gets the cord off the floor, but leaves it free to move back and forth with the tool. And the push of a button frees it entirely, should it be needed elsewhere.
—Greg Moore, Oakville, Ont., Canada

Quick tip: The sapwood edge of walnut boards or veneer makes excellent edging for lauan (Philippine mahogany) plywood. The color and texture are almost identical, and both accept stain the same.
—Dario Biagiarelli, Kirkville, N.Y.

Shopmade brad pliers

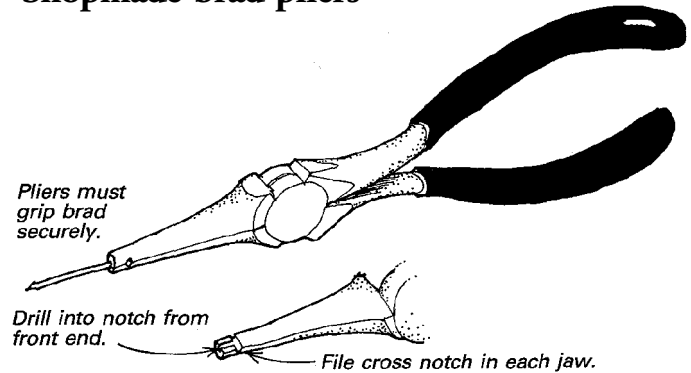

Here's how to alter a pair of needle-nose pliers to drive brads quickly and easily. Start by filing a slot across the inside faces of the jaw; locate the slot about $\frac{1}{8}$ in. to $\frac{1}{4}$ in. from the end of the pliers, depending on the brads you will be using. The slot should be deep enough and wide enough to grab the brad head snugly. Now, close the pliers in a vise, and drill straight down into the closed jaws until the bit reaches the slot. Use a drill bit that is slightly smaller in diameter than the brad shaft. It's a good idea to buff the end of the pliers so the rough edges won't mar the wood.

For maximum control when using the tool, it is important to keep a firm grip and rotate the nail slightly as you push it in. With a little practice, you'll be able to drive brads in at any angle, even sideways. —*Stephen D. Knight, Santa Rosa, Cal.*

Quick tip: Although lead can be hazardous to work with, it is occasionally needed for inlaying or for weighting small turnings. Those who use lead should be aware that there is a ready supply of it literally lying on the ground. You can find lead wheel weights (donated by cars with unbalanced wheels) all along the roads in urban areas. —*David Nebenzahl, East Palo Alto, Cal.*

Inexpensive screw chuck for turners

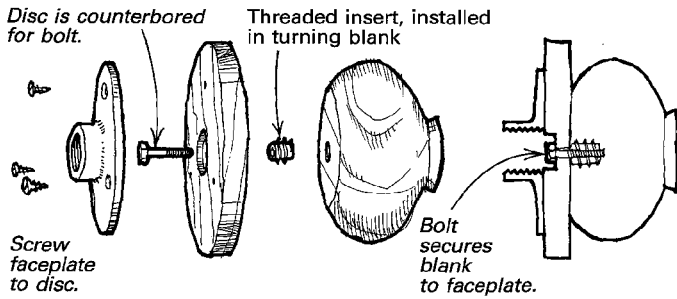

Metal threaded inserts can be adapted to make an inexpensive screw chuck for turners. First, screw a wood block to your faceplate, and turn a disc large enough to support the turning blank. Drill a centered hole through the disc, and then counterbore the hole on the back side to make a recess for a bolt head. Next, drill a pilot hole in the blank, and push in a metal insert, accord-

ing to the manufacturer's instructions. Now, you can quickly attach the blank to the chuck with a bolt sized to fit the insert.

This chuck is particularly useful for securing a bowl blank while you turn a foot on it for remounting the blank in a collet or three-jaw chuck. The screw chuck leaves the top surface of the work unmarred, except for the small pilot hole, making it possible to finish the bowl with only a small opening on the top. —*Dewey N. Garrett, Livermore, Cal.*

Ceiling joist clamping

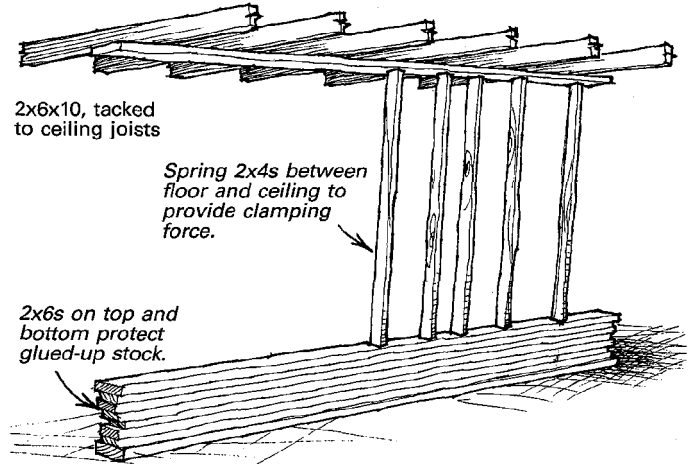

Here's a quick and easy technique that I use to laminate 2x4s into larger beams. First, lay a 2x6 on the floor, and level it to a 2x6 tacked to your shop ceiling. Make sure that the 2x6 on the

ceiling runs at a right angle to the ceiling joists. Now, one by one, quickly roll glue on the face of each 2x4 and stack the laminates. Cover the stack with another 2x6, and then spring pre-cut 2x4s between the stack and the ceiling to provide clamping pressure. The large amount of force is surprising; be careful you don't lift the joists too far. —David Foos, Los Angeles, Cal.

Making a safer taper jig

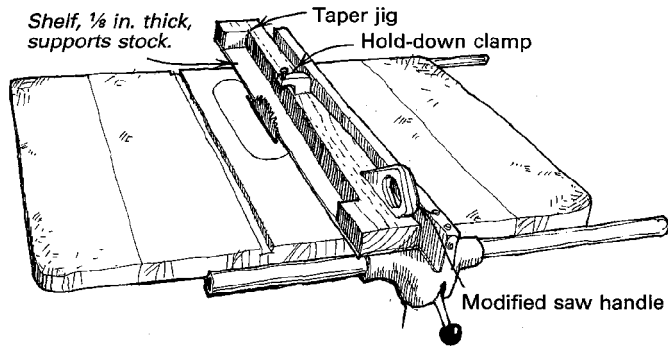

You can make a shop-built tablesaw taper jig safer and easier to use by adding a $\frac{1}{8}$ -in.-thick plywood or Masonite shelf to the bottom, and a hold-down clamp and a handle to the top. The shelf-and-hold-down combination holds the workpiece snugly enough to eliminate the balancing act that usually accompanies cutting tapers. The combination also lets you push the jig through as a unit with your hand far away from the blade. I find that the system is especially good for tapering narrow table legs.

—Joe Vollas, Fall River, Mass.

Screw-pocket drilling jig

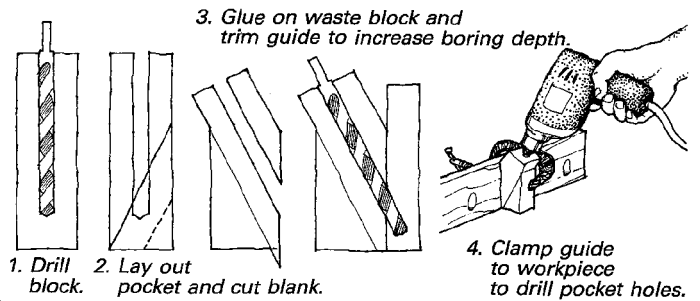

This jig makes it simple to drill screw pockets for securing a tabletop to its apron. Start with a 1-in.-sq. by 4-in.-long hardwood block, and drill a $\frac{3}{8}$ -in. hole in the end of the block as deep as your drill will reach. Draw the profile of the hole on the side of the block, and decide how deep and at what angle (usually 25° or so) you want your pocket. Then draw a line across the block to define the pocket, and saw the pieces in two along this angled line. Glue the sawn-off waste onto the other side of the block, as shown, to re-create a square corner. Now clamp the block to a scrap piece, and test-drill a pocket. Trim the end of the block to make the pocket deeper, if necessary. After you've drilled the pockets in the apron, finish by drilling screw-shank holes through the pockets with a hand-held drill. —E.G. Lincoln, Parsippany, N.J.

Methods of Work buys readers' tips, jigs and tricks. Send details, sketches (we'll redraw them) and photos to *Methods*, Fine Woodworking, PO Box 5506, Newtown, Conn. 06470-5506. We'll return only those contributions that include an SASE.

Hand-screw storage

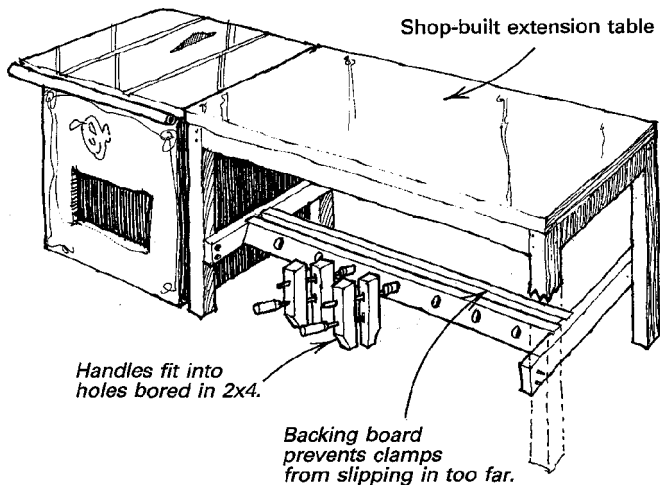

I utilize the space under my tablesaw extension to store hand screws. The system is neat and out of the way, and it allows quick selection of the clamp that is most nearly adjusted to the size I need. To make the storage rack, drill handle-size holes in a 2x4. Then mount the 2x4 at an angle in front of a backing board, which prevents the clamps from slipping in too far.

—Thomas R. Ormsby, Walworth, N.Y.

Shopmade vise dog

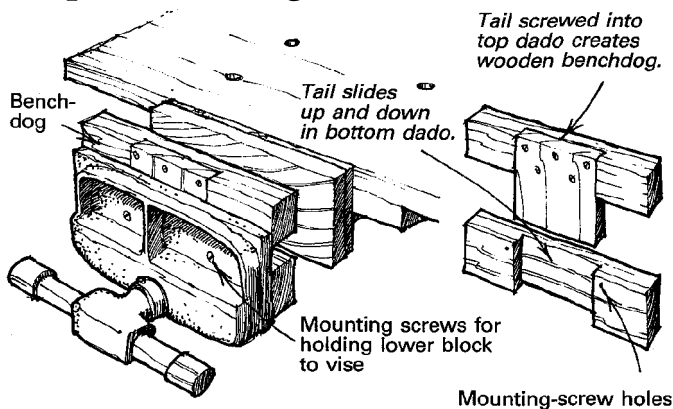

When I bought my woodworking vise, I saved a few bucks by choosing a model without a built-in iron dog that could be raised when I wanted to clamp a workpiece on the bench. After years of making do with various work-holding improvisations, I came up with my own system, which is shown in the sketch above.

To make the device, cut a 1-in.-thick hardwood block to match the height and width of your vise's outboard-jaw face. Hold the block in the vise and mark the locations of the jaw's mounting screws. Next, crosscut a dado in the block as wide as possible between the mounting screws. The depth of the dado should equal half the thickness of the wood. Now, rip the block in two just above the mounting-screw locations to make a top and a bottom. Attach a tail to the top piece, as shown in the sketch, to form a T-shaped dog. To complete the construction, take the bottom piece created when you ripped the block in two, screw it to the vise and pop in the dog. The tail of the dog should fit snugly in the dado so that the dog won't slip down after it's pulled up.

Now, instead of a 1-in.-sq., work-marring steel dog, you have an 8-in.-wide wooden dog that's not likely to damage your work. The width of the dog also makes it easy to hold workpieces securely. And if these advantages aren't enough, keep in mind that

if and when the dog wears out, it can be replaced in minutes with scrapwood.

— Robert Spalter, Lake Worth, Fla.

Quick tip: To prevent a piece of veneer from slipping when clamping pressure is applied, go over the veneer with a wooden roller right after laying the veneer on the glued substrate.

—Dario Biagiarelli, Kirkville, N.Y.

Ripping thin strips on the radial-arm saw

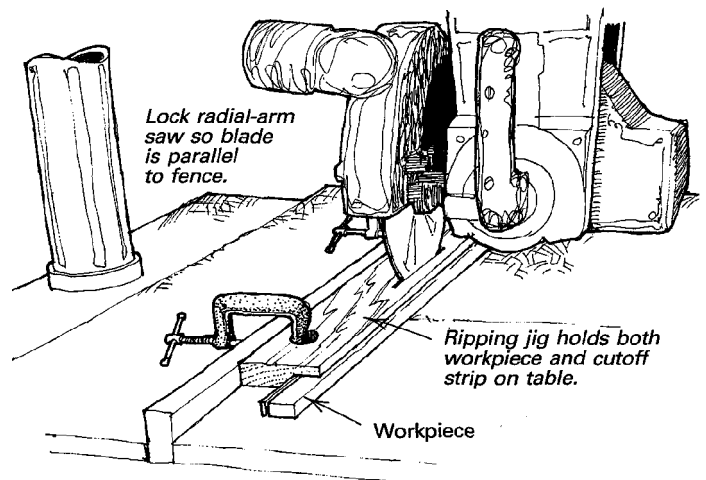

Before I developed this fixture for cutting thin strips, I found that I ruined about as many strips as I kept. The rotation of the blade tends to lift the workpiece or the strip off the table, and, if conditions are not perfect, the strip will catch on the blade and break. This fixture, however, eliminates this problem by holding both the workpiece and the just-cut strip on the table. To avoid problems, cut with a sharp hollow-ground planer blade, set the sawblade parallel to the fence and install a fingerboard before feeding the stock.

—Harold Nachlin, San Diego, Cal.

Jointing long boards with a router

Rout between boards to joint edges.

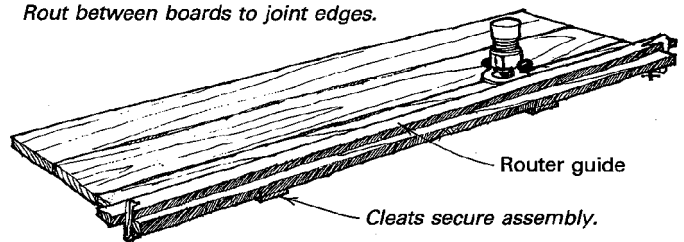

When I needed to joint the edges of several 12-ft.-long boards for gluing up a tabletop, I first tried using my jointer. However, even with auxiliary rollers on both ends of the jointer bed, I was not able to obtain a truly straight edge over the entire 12-ft. length. So I turned to this router-based method and achieved surprising success.

First, lay the long boards on the bench, good-side down, in the desired arrangement. Push the boards together as closely as possible, minimizing wide gaps between edges. Then screw several scrap cleats across the boards, putting at least two screws through the cleats into each board to keep the entire assembly from racking. Finally, scribe a few registration lines across the underside of the boards to assist later in glue-up.

When this assembly is complete, flip it over so that the good sides of the boards are facing up. Then, using a straightedge as a guide and a 1/4-in.-dia. straight bit set slightly deeper than the thickness of the boards, rout down the middle of each gap be-

tween boards. This will remove stock from the edges of both boards, leaving a uniform gap between them. Remove the cleats, and glue up the boards as usual. The real beauty of this technique is that the straightedge used with the router does not have to be perfectly straight. Any slight waves or bows will be compensated for by an equivalent wave or bow on the other side.

—Michael A. Mason, Greendale, Wisc.

Storyboard for routing dados

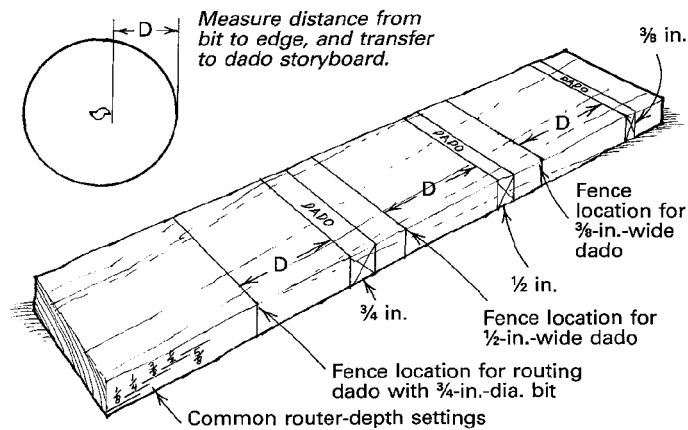

Here's a quick and accurate method to determine where to clamp a guide fence when routing dados. First, measure the distance from the outside of your router base to the edge of the bits you commonly use for dados. Now, transfer each of these measurements to a 3/4-in.-thick, straight piece of wood, as shown

in the sketch. To use the Storyboard, simply align the dado lines with the desired dado location, and transfer the fence location mark to the workpiece. Also mark some commonly used depths on the edge of the Storyboard to facilitate setting the depth of the bit.

—Keith Schubert, Irvine, Cal.

Wedges for edging plywood

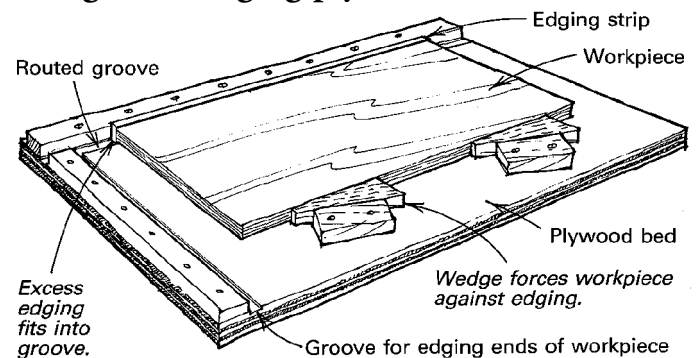

Here is a method that I use to attach 3/8-in.-thick, solid-wood edging to 3/4-in.-thick plywood shelves and case members.

To make my edge-gluing fixture, as shown in the sketch above, cut a panel of inexpensive 3/4-in.-thick fir plywood to serve as the bed. In this bed, rout a 5/8-in.-wide by 1/16-in.-deep groove about 1 1/2 in. from the edge. Screw a batten along the edge of the plywood so that the batten slightly overhangs the routed groove. Now, saw several wedges, all the same size and taper, and an equal number of rectangular pressure blocks about 1 in. shorter than the wedges. With a sample workpiece in

place in the jig, screw the blocks to the bed, as shown, so that the wedges can be tapped home.

To use the jig for $\frac{3}{4}$ -in.-thick shelves, first rip $\frac{3}{8}$ -in.-wide solid-wood edging from a board that has been planed to $\frac{7}{8}$ in. thick. Cut the edging to length, and place it in the groove against the batten. Spread glue along the edge of the workpiece, lay it against the edging and tap the wedges home with a hammer.

After the glue has set, tap the narrow end of each wedge to unclamp the work, and remove the workpiece from the jig. Trim the edging flush with the plywood surface using a router jig or handplane. To edgeband the ends of the workpieces, follow the same procedure, but with the groove and batten located at the end of the plywood bed. —Abram Loft, Rochester, N.Y.

Keeping a paint-can lip dry

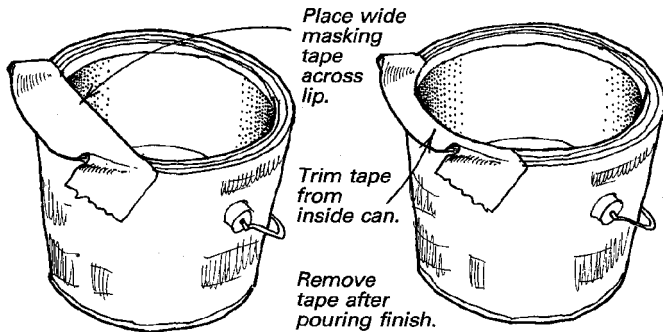

Here's how to keep varnish, lacquer or paint out of the lip of often-opened cans. After wiping the lip dry, apply a piece of

2-in.-wide masking tape across the mouth of the can. Fold down the ends of the tape, as shown in the drawing, to create a dam at the edges. Now trim the tape away from the inside of the can with a razor blade or knife. After pouring out the finish, just strip the tape off to reveal a perfectly clean lip ready for resealing,

—Daniel A. Koblosch, Redondo Beach, Cal.

Quick tip: Bandsaw blades make precise gauges for indexing jigs and marking layouts. For example, a 6-t.p.i. blade is a ready reference for thirds or sixths of an inch.

—Robert Vaughan, Roanoke, Va.

Cutting multiples

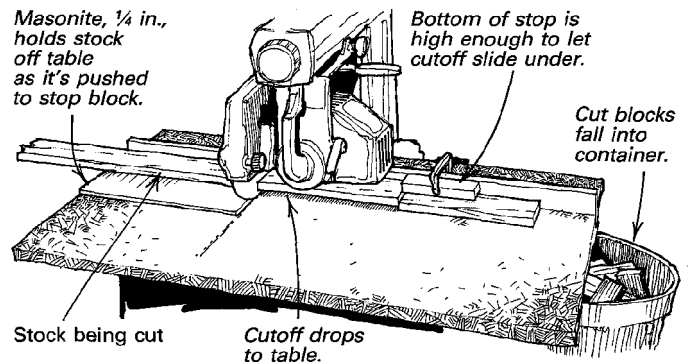

When I had to cut hundreds of 8-in.-long blocks, I set up my radial-arm saw with an auxiliary Masonite table and a floating stop block, as shown. I slide stock (already ripped and planed to the

right dimensions) in from the left and over the Masonite until it butts against the stop, and then I cut it. The block drops to the saw table, and the next piece being cut moves it under the stop and along the table. Eventually, the block will fall off the end of the table into a container. —*Gothard Knulson, Fargo, N.D.*

Spring-loaded hold-ins

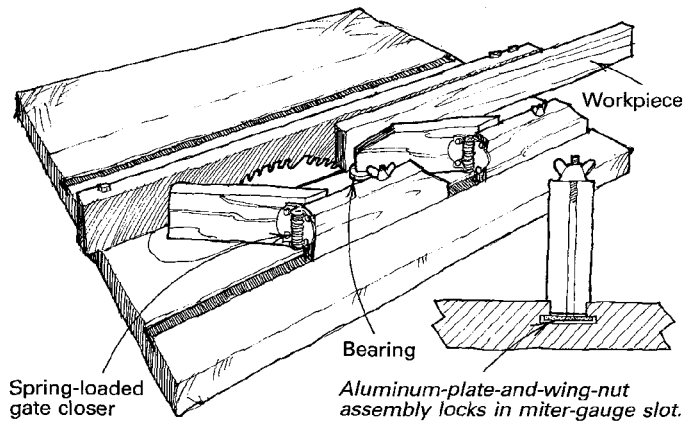

This pair of table saw hold-ins uses gate-closer springs to apply pressure on the piece being cut. I added an old shaft bearing to the front hold-in to reduce friction. Since my saw has a T-slotted miter-gauge track, I designed the wing-nut-and-aluminum-plate locking device to take advantage of it. On saws that don't have a T-slotted track, just size the hold-ins so they can be press-fit into the miter-gauge track. —*Frank Usher, Nepean, Ont, Canada*

Quick tip: A convenient way to hold Alien wrenches, chuck keys and other small tools to machines is with a small magnet. To prevent the magnet from coming along with the tool when you grab it, wrap a strip of tape around the tool and place that portion against the magnet. The tape will reduce attraction enough so that the magnet will stay put when the tool is pulled off.

—*Dario Biagiarelli, Kirkville, N.Y.*

Router base with extension wing

I have only one router, and I wanted to use it as both a table-mounted and hand-held tool. However, I found conventional router tables were too bulky, and frequently mounting and removing the router was too cumbersome. So I created a router base, as shown, with a wing that extends $3\frac{1}{2}$ in. past the tool's base. I made this wing from $\frac{1}{2}$ -in.-thick clear-plastic Lexan, and screwed the wing to the router as a substitute for the manufacturer's stock baseplate. With the wing on the router, I can create an instant router table by running drywall screws through holes in the extension wing to fasten the inverted router to any suitable surface, such as a bench, windowsill, dock edge, toolbox or sawhorse.

As an added bonus, when I want to use the router as a hand-

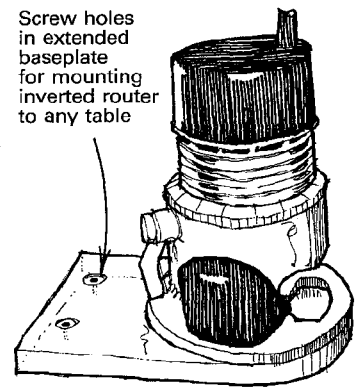

held tool, the extension wing makes it easier to follow guides and keep the router level on narrow work and end cuts.

—Gordon Elliott, Friday Harbor, Wash.

Carriage for bandsawing logs

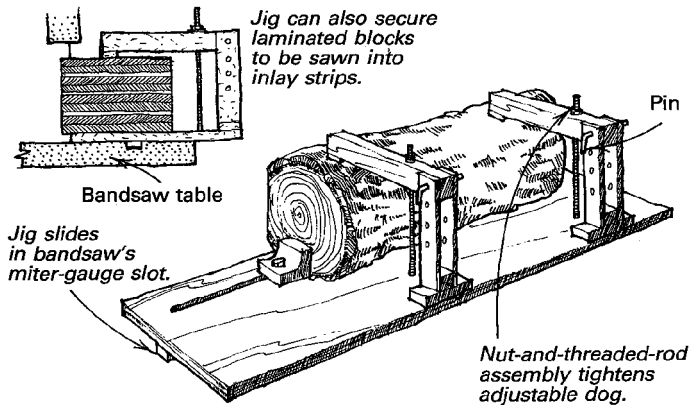

A "Methods of Work" in *FWW* #84, p. 18 illustrates a carriage fitted with a pipe clamp to hold small logs as they're being bandsawn. The jig I use for this holds the work with two adjustable wooden dogs, rather than a pipe clamp. This versatile jig is also good for resawing square, glued-up stock into thin boards, which I use for inlays and overlays. —Don Taylor, Deer River, Minn.

Quick tip: One day I grew frustrated with brushing and blowing sawdust from my radial-arm saw work surface even though

my shop vacuum was hooked up to the port in the blade guard. Then a light went on. I simply connected an extra hose to the vacuum's exhaust outlet and taped the other end to the side of the blade guard with the hose aimed down. The air flow keeps the work area clear of dust. —Bob Maxwell, Washington, D.C.

Improved edge clamp

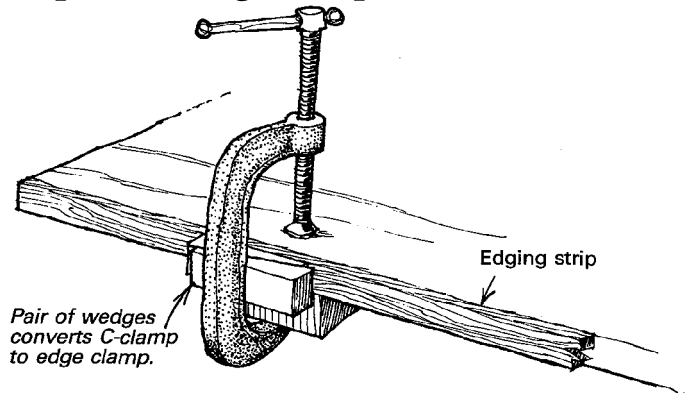

To improvise an edge clamp, all you need is a regular C-clamp and a couple of wedges. If the clamp's back is curved where it hits the wedges, use a block to realign the back to a straight section. —Don H. Anderson, Sequim, Wash.

Methods of Work buys readers' tips, jigs and tricks. Send details, sketches (we'll redraw them) and photos to *Methods*, Fine Woodworking, PO Box 5506, Newtown, Conn. 06470-5506. We'll return only those contributions that include an SASE.

Surfacing small pieces with a router

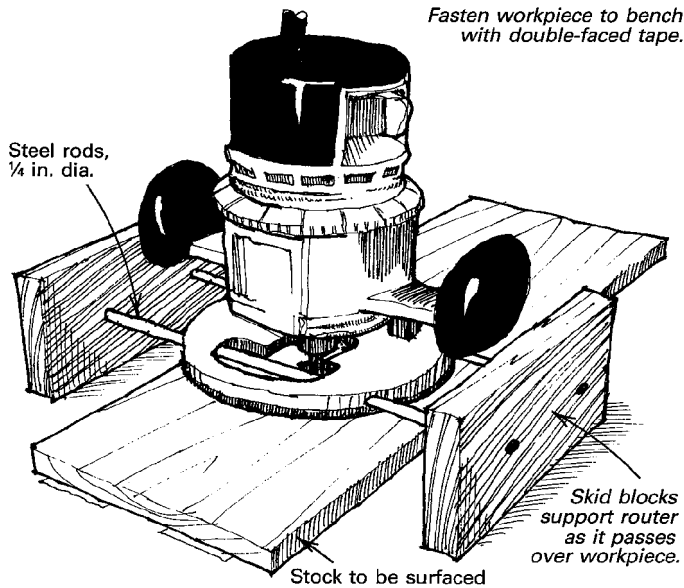

I recently needed to thickness-plane some small pieces of cherry to make a box. I don't have a planer, but I did the job quite satisfactorily using my router and the simple jig shown in the sketch.

To make the jig, run two 1/4-in.-dia. steel rods through the guide holes in the router base. Tap the ends of the rod into 1/4 in.-dia. holes bored into two wooden skid blocks that are large enough to hold the router above the workpiece to be surfaced. Then, chuck a 3/4-in.-dia. carbide-tipped straight bit in the router.

Before using the jig, resaw the workpiece to the approximate thickness that you need, and fasten the wood to the benchtop, rough side up, with double-faced tape. Then move the router jig over the rough surface of the board, taking a light cut with each pass. It only takes a short time to surface and thickness the workpiece. —Richard Adler, Gulf Breeze, Fla.

Modifying drill bits for plastic

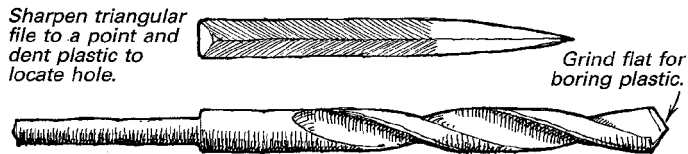

Many woodworkers use plastics for jigs and fixtures that require that holes be drilled in the material. The problem is that most plastics are liable to crack or split if they are drilled incorrectly. You could probably use a regular twist drill up to 1/8 in. dia. without trouble, but larger bits tend to grab as they break through the plastic. You can prevent this problem and obtain clean, smooth holes by honing a flat on the cutting edges of the bit, as shown in the sketch.

To accurately start a hole in plastic, you need to make a small dent in the material for positioning the drill point. Do not use a center punch, as you might do on metal, because the plastic is likely to crack from the force of the punch. Instead, make a dent in the surface with a piece of an old triangular file, which has been ground to a point as shown. Press and rotate the file backwards and forwards to make a dent. —Percy W. Blandford, Stratford-upon-Avon, England

Quick tip: A great non-slip surface for holding wood for sanding and shaping is Slip-Stop (Cameo Manufacturing Inc., 121

Landmark Drive, Greensboro, N.C. 27409). The rubbery, porous material, which comes in rolls, is often available from dealers carrying supplies for recreational vehicles.

—Kenneth C. Palmer, Lakeland, Fla.

A devil of a scraper plane

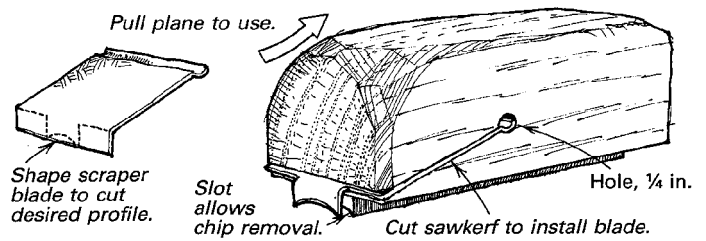

When I need to cut a simple bead or groove in a workpiece and can't use a router, I make a scraper plane using Red Devil brand scraper blades. These steel blades, which are available at most hardware stores, are easily shaped and sharpened with a file. To make the body of the plane, drill a 1/4-in.-dia. hole through a hardwood block and saw a kerf into the hole so that you can fit the blade into the block, as shown in the sketch. Shape the sole of the plane to match the contour of the blade and to adjust the depth of cut. Also, leave a 3/16-in. slot in front of the cutting edge to facilitate chip removal. —Alden Trull, Union, Maine

Quick tip: A good way to keep laminates separated from the underlying surface when gluing with contact cement is to place strips from old Venetian blinds between them. When the laminate is properly positioned, the wide, thin strips can be easily removed. —JA Wilson, Lexington, Mass.

Hardware storage rack

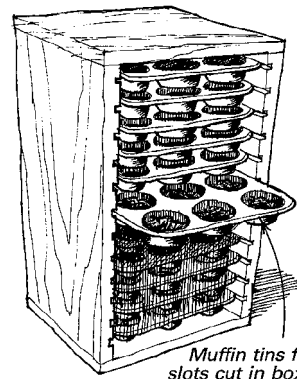

In our antique-auto restoration shop we need a large inventory of standard screws, nuts, bolts and washers in a variety of sizes. When we finally got tired of messing with those flimsy metal cabinets with the little plastic drawers, we built this rack for storing hardware in muffin tins. The rack itself is a simple box with grooves cut into the sides; you could build it any way you want. The main advantages of our setup are compactness, sturdiness, visibility of hardware (when the drawer is pulled out) and number of bins. Our rack uses 12 muffin tins, each with 12 compartments, giving us an ample 144 bins per unit. The muffin tins retail for around \$4, so it is worth watching for a sale or scouting up a wholesale price.

—Durward Brown and Wallace Wiebe, Alva, Okla.

Quick tip: Plane a flat on the handles of narrow chisels and gouges to keep them from rolling around or off the bench. If the flat is aligned with the underside of the blade, it will also position the tool so that you can pick up the tool the right way without looking.

—Percy W. Blandford, Stratford-upon-Avon, England

Quick tip: You can recycle dirty mineral spirits by letting the liquid set in a cool spot for a couple of weeks. Decant the clear stuff into an old mineral-spirit container, and then dispose of the residue. —Gene Thoma, New Brighton, Minn.

Plunge router slotting jig

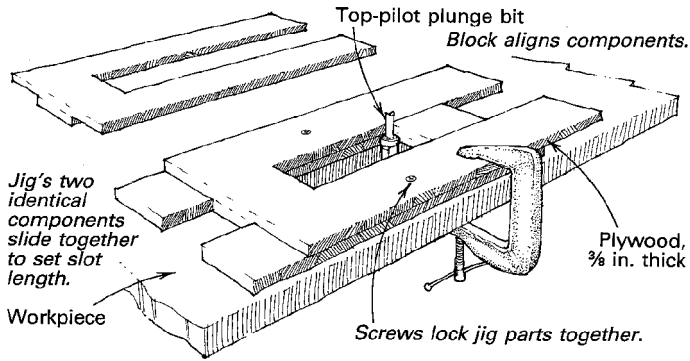

I build cabinets for audio, video and computer equipment. Each cabinet must be equipped with different-size access slots, depending on the equipment to be stored. To cut the various lengths of slots required, I came up with the router jig in the sketch. The jig, which I've found saves time and gives good results, is based on the two interlocking, identical parts cut from $\frac{3}{8}$ -in.-thick plywood. A block glued to each U-shaped component aligns the pieces as they slide together. For best results, the pieces must fit together snugly.

To use the jig, slide the halves to the desired slot length, secure the assembly with two screws and clamp it down in the desired location. I use a plunge router with an Amana top-pilot (on the shaft) flush-trimming plunge bit, which has several advantages over a standard router fitted with guide collars or bushings. First, with a plunge router, you can rout the slot incrementally without having to stop and reset the cutting depth, and second,

with a flush-trimming bit, you don't have to widen the jig slot to compensate for the collars. I have made several jigs for various slot widths, but the $1\frac{1}{4}$ -in. width gets the most use.

—Warren W. Bender Jr., Medford, N.Y.

Ripping logs on the bandsaw

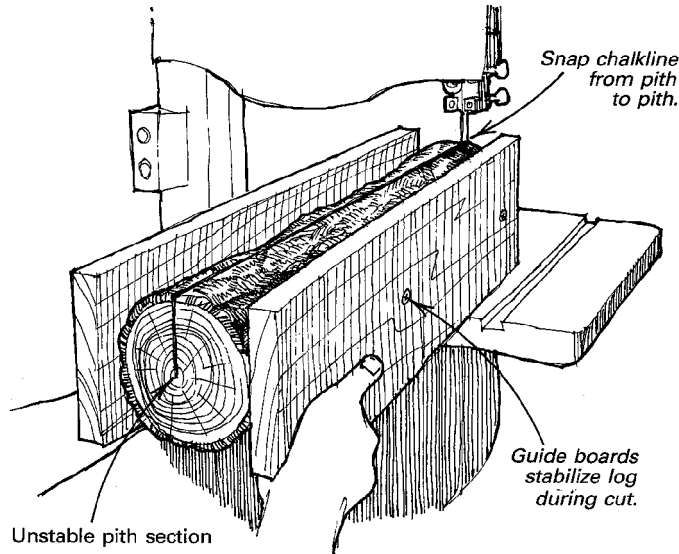

Here's an easy, accurate way to rip short logs on the bandsaw to make bowl blanks. First, determine the best line through the length of the log, and then place the log on the saw table

or other flat surface, so it is lying just as you want it to go through the saw. Cut two 1x10s about as long as the log, and secure one of these pieces to each side of the log with drywall screws. The bottom edges of these guide boards should rest on the saw's flat surface, to stabilize the log.

Now drive a nail into the pith on one end of the log. Stretch a chalkline from this nail down the length of the log, center it on the pith at the opposite end of the log and strike the line. Carefully following this chalkline, rip the log. Sawing through the pith, which is prone to crack as the wood dries, ensures that this unstable section won't end up in the finished bowl. Remove the guide boards and rip the halves again with the first-cut surface held against a fence set so the saw will take 1/2 in. or so off what will be the bottom of the bowl. This gives you a flat surface to set on the saw table when you cut out the round bowl blank and provides enough space for attaching a lathe faceplate.

—Floyd Rogers, Lewisville, N.C

Quick tip: To prevent tools from rusting in a canvas tool roll, soak the canvas in clear kerosene and let it dry.

—Ken Klosterbaus, Romeo, Mich.

Quick tip: To stop tools from rusting, spray your tool roll with a silicone-base, water-repellent fabric spray. The spray reduces the amount of moisture that the roll picks up from the air.

—Robert Davidson, Traverse City, Mich.

Quick tip: A bench grinder will heat up tool steel very quickly. To avoid overheating a tool when sharpening, work on two tools at a time; when one starts to feel warm, set it down and pick up the other.

—Dario Biagiarelli, Kirkville, N.Y.

Drilling cribbage-board holes

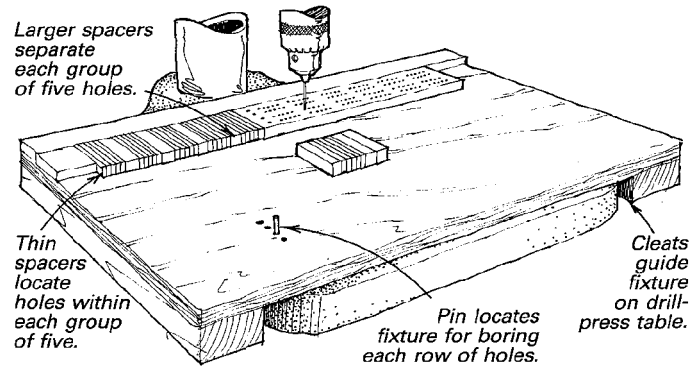

Drilling holes in a cribbage board is time-consuming and very exacting. The fixture shown here produces fast, accurate holes by using small spacers to locate them. Four thin spacers are used for the holes within each group of five, and every fifth spacer is thicker, to set the wider areas between the groups of five. To use the fixture, put all the spacers in place and line up the bit with the first hole. Then drill the first hole, remove one spacer, move the board to the left, drill the next hole and move the board again. Repeat this process until you have completed the row. Realign the jig and replace the stack of spacers to begin the next row. One good method for locating subsequent rows is to slide the jig toward the drill-press post and pin it in place. The whole operation is almost as much fun as playing cribbage.

—Charles W. Whitney, Mount Vernon, Ohio

Clamping picture frames with coil springs

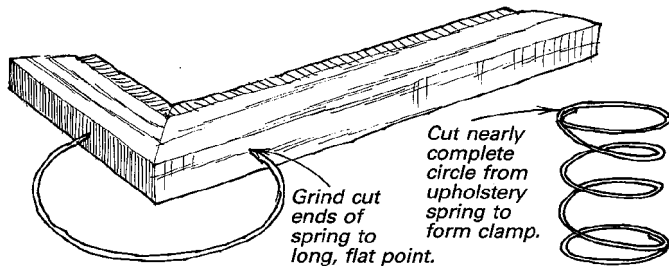

Here's a method for clamping picture frames that I learned years ago at the shop of a New York City framemaker. Use spring clamps made from upholsterer's coil springs to exert pressure. The sharpened ends of the circular springs bite into the sides of the mitered frame pieces putting pressure exactly where it's needed—on the glued miter.

To make the rings, saw nearly complete circles from the coil springs. Then carefully sharpen the cut ends on a belt sander or grinding wheel to form long, flat points. Two upholsterer's coil springs will yield two or three complete sets of four spring clamps of various sizes and tensions. —*Steve Manville, Amagansett, N.Y.*

Quick tip: Putting fresh sandpaper on an orbital sander can be frustrating if you start with the paper slightly misplaced. I keep handy a piece of plywood the same size and thickness as the sander pad. Fit the paper to this block, carefully creasing the four 90° bends. After that it easily falls in place on the sander pad and clamps down smooth and tight. —*Joseph T. Logan, Easton, Md.*

A wooden spring drawer latch

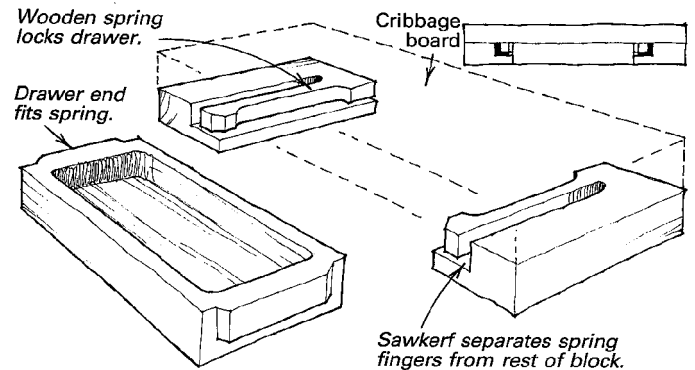

This cribbage-board drawer slides into the board and is held in place with wooden springs. The springs are wooden fingers routed into small blocks attached to the bottom of the board. To make the fingers, rout the indentations on the outside of the fingers that will hold the drawer in place. The cut should be about half the thickness of a $\frac{3}{16}$ -in.-dia. bit. Then, with the same bit, rout the slot that creates the finger in one pass, starting from the outside and moving to the root of the finger. Separate the finger from the rest of the workpiece, as shown above, by making a pass with a thin-kerf blade on a tablesaw. To tune the fingers to the proper tension, change the thickness of the shaft of the finger. Be careful, even a small change will affect tension. Straight-grain woods with good split resistance, such as maple or ash, are excellent choices for these springy fingers.

—*Michael O'Banion, Westminster, Md.*

Router-made latching lid

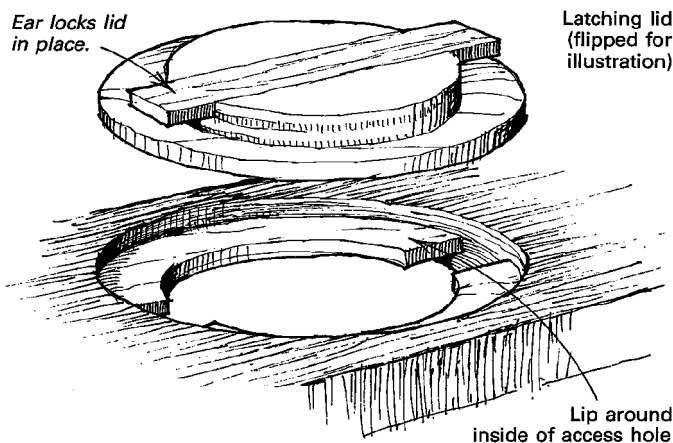

I designed this circular latching lid to conceal the access compartment in the back of a clock, but it could be used in other applications as well. The latch is milled almost entirely with a router pivoting on a trammel point. The dimensions here are based on using $\frac{3}{4}$ -in.-thick material.

Start by drilling a small hole for the trammel point through the panel to be accessed. Pivoting your router around this hole, rout a circular groove $\frac{1}{4}$ in. deep with a $\frac{3}{4}$ -in.-dia. straight bit. The outside diameter of this groove should be about $1\frac{1}{2}$ in. larger than you want the access hole to be. Without changing the depth setting, turn the workpiece over and rout a groove on the other side using the same pilot hole and

trammel setting. Now decrease the trammel radius by $\frac{3}{4}$ in. (the bit diameter) and rout a circular groove at progressively deeper settings until you're all the way through the workpiece. This will leave a $\frac{1}{4}$ -in.-thick by $\frac{3}{4}$ -in.-wide lip around the inside of the access hole.

To make the lid, use the trammel to rout a disc from separate stock that will fit snugly in the recess of the access hole. Next, decrease the trammel's radius by $\frac{3}{4}$ in. and rout a circular rabbet $\frac{1}{2}$ in. deep on what will become the inside of the lid.

Once the pieces fit together satisfactorily, rout a straight groove $\frac{3}{4}$ -in.-wide by $\frac{1}{4}$ in. deep across the inside of the lid. Glue a strip of solid wood in this groove to make the latching ears, as shown in the sketch. Mark where the ears contact the lip around the inside of the access hole and remove these two areas with a coping saw. You should now be able to push the lid flush with the back and lock it by turning. To complete the lid, add a handle, and wax the parts for easier twisting and removal.

—Russell Salter, Pittsburgh, Pa.

Quick tip: Here's a trick that makes it easy to square up a stack laminated block. When preparing the laminates, leave the bottom board slightly wider than the rest, with one long edge machined straight and square. During glue-up, have the squared edge proud of the rest of the stack, and then run this edge against the tablesaw rip fence to square the other side.

—Dario Biagiarelli, Kirkville, NY.

Methods of Work buys readers' tips, jigs and tricks. Send details, sketches (we'll redraw them) and photos to Methods, Fine Woodworking, PO Box 5506, Newtown, Conn. 06470-5506. We'll return only those contributions that include an SASE.

Drill-press milling machine

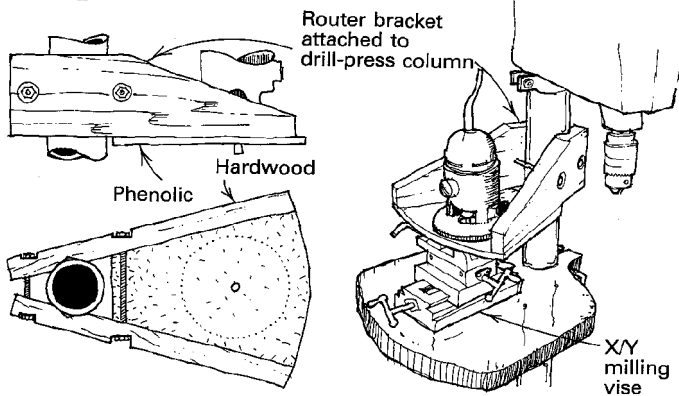

This method grew out of my need to make some small, precise wooden prototypes a few months back. First I purchased one of those X/Y milling vises and clamped it to my drill-press table. Then I made a simple router bracket that locks onto my drill-press column. The permanently attached bracket, which swings out of the way for drilling, enables me to quickly and easily set up for milling whenever I need to.

For the bracket, I chose phenolic for the baseplate because of its flatness and rigidity and 2-in.-thick hardwood for the arms. I made the hardwood arms first and clamped them to the column with threaded rod. Then I screwed the baseplate to the arms.

To use the milling machine, I first make a crude height adjustment between the vise and router by moving the drill-press table up or down, and then I make precise adjustments with the router itself. For quick router attachment and removal, I purchased an extra router base that I keep screwed to the jig.

—Michael J. McGinnis, Santa Rosa, Cal.

EDITORS NOTE: The following two methods describe ways to use an asymmetrical router base to solve different setup problems.

Asymmetrical router base simplifies setups

Roff's router base

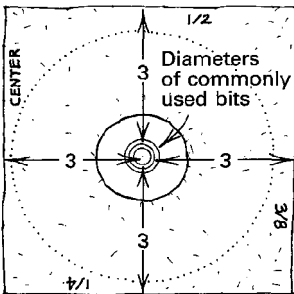

Trivino's router base

Offset for cutting 3/8-in.-wide groove with 1/2-in.-dia. bit

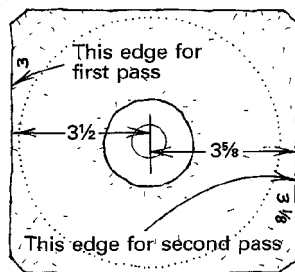

I used to get frustrated with the inordinate amount of time it took to set up my router for even the simplest cuts. The main problem was that the distance from the edge of the router base to the bit was always some weird dimension like 2 19/32 in. So recently, while making some new custom router bases out of Lexan, I got an idea. I cut the rectangular base so that each edge of the router base will be exactly 3 in. from the edge of one of my standard bits. For example, if I am using a 1/4-in. bit, the edge marked 1/4 in. will be exactly 3 in. from the edge of the bit. I also made one edge 3 in. from the center of the bit, which is frequently useful (see the drawing, above left). In addition to writing the bit size on each edge, I color-coded the edges with per-

manent marking pens to help me remember which bit/edge I am using. To make the base, I cut the Lexan slightly oversize, and then, after mounting the router and making test cuts, I ran the base over a jointer to carefully trim each edge to the exact offset needed.

—Derek Roff, Albuquerque, N.M.

Router base for grooving in two passes

Recently, I needed to cut a large number of 5/8-in. grooves across several large pieces. Because I dislike using cutters larger than 1/2 in. in my small router and because I wanted to minimize the number of router-fence setups, I quickly designed and cut the asymmetrical router-base plate shown in the drawing.

The theory is quite simple. Simply vary the base's offset by the amount you want to enlarge the groove. In my case, I wanted to enlarge the 1/2-in. groove to 5/8 in. So I cut the base 3 1/2 in. from the center of the bit on one side and 3 3/8 in. on the other, a difference of 1/8 in.

To use the fixture, set a fence parallel to the line of cut, make one pass with the first edge against the fence, and then make another pass with the second edge against the fence. One setup, two passes, one odd-size cut.

—Alien Trivino, Rochester, N.Y.

Quick tip: Measuring tablesaw-blade height for a dado or groove cut can be a problem, especially if the blade insert is not exactly level with the tabletop. Instead, mark the desired height on the face of a scrap board that is longer than the insert, and clamp the board to the fence flush on the table with the mark centered over the blade opening. Lower the blade and position the fence so that when the blade is raised, it will skim the face of the scrap. Turn on the saw and raise the blade until it just touches the line.

—Dario Biagiarelli, Kirkville, N.Y.

Improved radial-arm saw miters

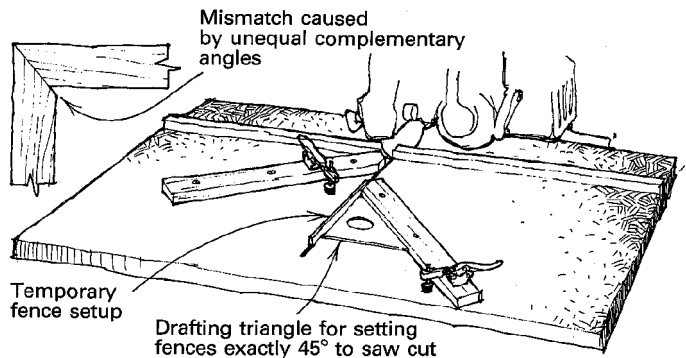

In "Methods of Work," FWW #86, Steven Springston describes a method of sawing picture-frame miters using complementary angles. Although Mr. Springston's method will produce a perfect 90° angle, if the saw's 45° setting is off much, the technique may produce miters with faces that don't match. This problem can be especially troublesome on highly detailed moldings. By contrast, my method, illustrated above, uses the actual cut line of the blade for its registration and avoids the mismatch problem.

Clamp an auxiliary table on the main sawtable, and cut a 1/8-in.-deep sawkerf into the table. Into this kerf insert a 1/4-in.-wide strip of 1/8-in.-thick hardboard to act as a temporary setup fence. Place a 45° drafting triangle against the fence, and use it to set the position of the left-side fence. Screw the fence to the table so it overlaps the kerf a bit; it will be trimmed later. Flip the triangle to the opposite side of the hardboard, and repeat the procedure described for the right-side fence, as shown in the drawing.

Methods of Work (continued)

Place the right-side fence back far enough to allow room between the fences for the workpiece. The best miter cuts are made if the workpieces are held firmly in place on the table. To accomplish this, install toggle clamps on the fences. Bear in mind that the right toggle clamp will interfere with the saw's motor unless it is placed well back on the right-side fence. To finish the setup, remove the hardboard insert and cut through the fence overlaps. You are now ready to produce perfect miters.

—Tom Stipanovich, Cambridge, Ont, Canada

Quick tip: Use a good pencil sharpener on the end of a dowel to form a point that can reach into an inside corner to remove fresh glue. You can also sand the tip of the dowel at an angle and use it to clean out dado grooves.

—L. Frederick, Aspen, Colo.

Gluing up mitered legs

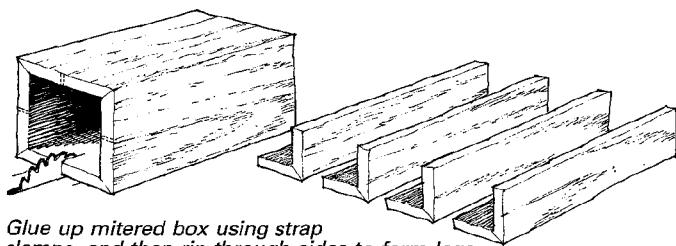

Glue up mitered box using strap clamps, and then rip through sides to form legs.

I designed a coffee table with 3-in.-wide, L-shaped legs mitered at the corners. But with my small selection of clamps, I couldn't figure out an easy way to glue up the mitered leg joints. Then I

got an idea. Instead of making each leg separately, I made all four at once. The trick was to glue up a long mitered box using strap clamps and then to rip through the middle of each side to form the four legs. —Steven H. Klotz, West Bloomfield, Mich.

Hot-melt glue blocks

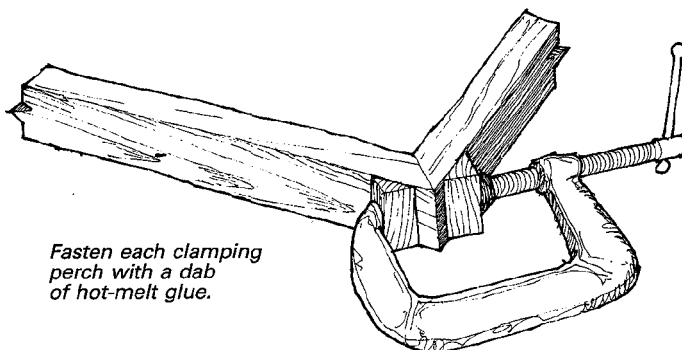

Fasten each clamping perch with a dab of hot-melt glue.

Mitered glue joints are almost impossible to clamp even using expensive corner clamps and other jigs. Here is a simple way to apply pressure exactly where it is needed. Cut two triangular blocks from scrapwood. Glue these onto the outside of the pieces to be mitered to create two parallel clamping perches. The trick is to use only a dab of hot-melt glue to fasten the perch. Now assemble the joint using common C-clamps to apply pressure across the joint. The hot-glued perches stay in place nicely but can easily be popped off later with a chisel. A few strokes with sandpaper removes any glue residue, and then the joint is complete. —Larry Morse, Framingham, Mass.

Quick tip: A clean collet is an absolute must to avoid the disastrous consequences of a router bit slipping up or down in the collet when routing. A gun cleaning kit for a 22-caliber weapon has everything you need: a small brass brush and patch cleaning swabs that fit just right in the collet. —L. Frederick, Aspen, Colo.

Laying out cams with string

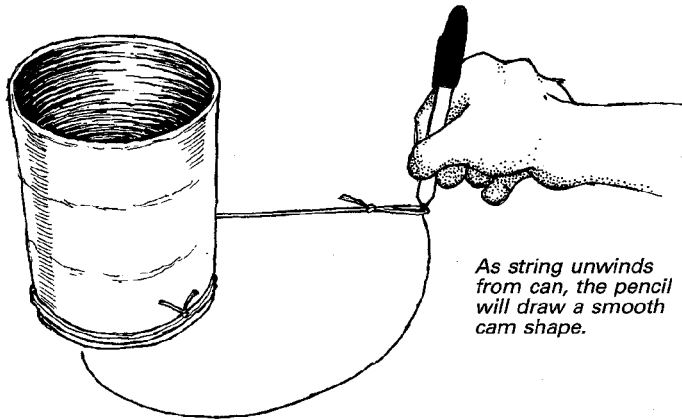

The easiest way to draw a cam is to use the unwinding string principle—tie a string around a cylinder of suitable size to create the desired cam shape. Aluminum food cans are often about the right size. First, tie a length of string around the can, and tie a loop in the end of the string. Then wind the string fully around the cylinder, and place a pencil in the loop with the point where the cam is

to begin. Unwind the string by moving the pencil away from the cylinder. The point of the pencil will scribe a cam that expands in proportion to the diameter of the cylinder. Because the distance from the center of the cam increases at a constant rate, the resulting cam will have a smooth and controlled action.

—E. W. Carson, Blacksburg, Va.

Metal pins eliminate miter slippage

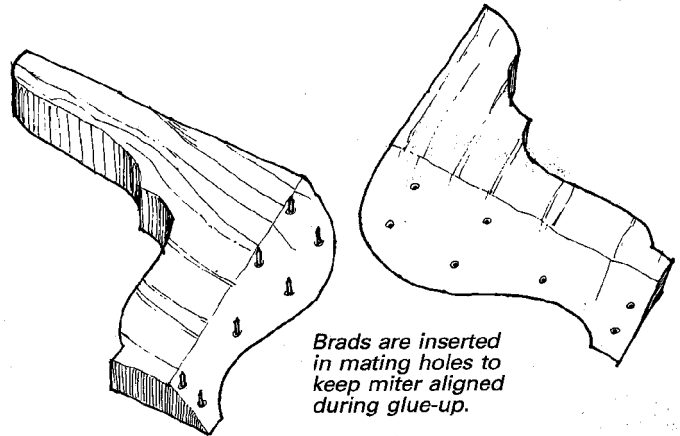

This method of using metal pins to prevent miter slippage during glue-up is good on odd-shaped mitered pieces, like the bracket feet in the sketch, that might otherwise require special clamping jigs.

Start by placing one of the joint halves, miter side up, on the drill-press table. Select a bit the same size as an 18-gauge brad,

and begin drilling shallow holes in the miter face in a pattern that suits the job. Place brads in these holes, nip the heads off flush with a side cutter, and then fish each brad out of its hole and reverse it end for end so the point is up. Now align the two halves of the mitered molding, and push straight down on the sharp pin points. The mating half will have an exact layout for drilling a matching set of pin holes.

After the holes have been drilled in the mating half, remove the original pins. Put new brads in the original holes, cut these to a suitable length and reverse them to put the points up. I find it helpful to countersink each of the holes slightly, to help each pin "find" its matching hole and ensure the assembly goes smoothly.

The joint can now be put together dry and pressed tight. If you have been careful, the joint will fit almost perfectly. A slight overlap can usually be corrected by a small amount of pressure or twisting.

—J.A. Binns, Tucson, Ariz.

Magnetic shop helper

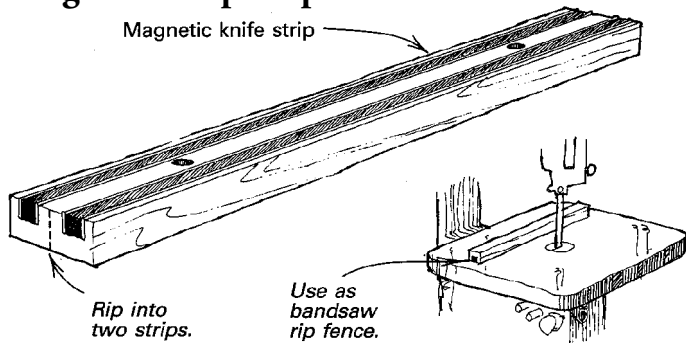

The multipurpose magnetic strip I use in my shop started from one of those inexpensive two-track magnetic knife racks found at kitchen-gadget stores. I bought one of the racks, ripped it down the middle to form two strips and then sanded the fresh edges to remove the sawmarks.

I use one of the strips as an instant fence on my bandsaw for ripping small strips of wood. The strips also can be used to position jointer blades at the right height during replacement, as a fingerboard with a piece of flexible plastic attached to one side, and for pinning plans or drawings flat on a steel surface.

—Jim Van Dreese, Wisconsin Rapids, Wisc.

Plumbing caps as tool ferrules

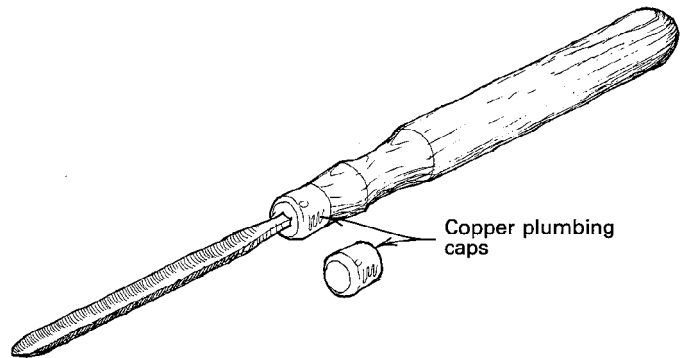

I use common hardware-store copper plumbing caps for ferrules on my custom turning tools. To use the caps, I turn a tenon on the tool handle to fit the inside diameter of the cap.

Then I drill (and file if necessary) an opening in the cap to fit the shank of the tool. After fitting the tool to the handle, I polish the cap and spray it with a clear sealer to keep it looking good. The caps, which average about 40 cents each, are available in sizes from ¼ in. dia. up to 2 in. dia.

—Wayne Knuteson, Murray, Ut.

Preparing octagonal spindle stock

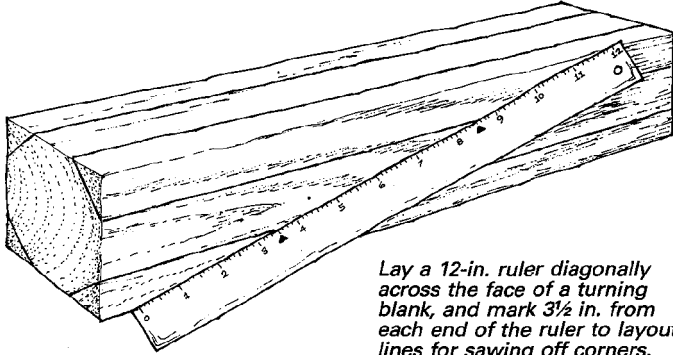

Lay a 12-in. ruler diagonally across the face of a turning blank, and mark 3½ in. from each end of the ruler to layout lines for sawing off corners.

Here is a quick method of marking the amount of corner stock to be removed from a square blank you want to turn on a lathe. Simply lay a 12-in. ruler diagonally across the timber with the zero mark aligned with one edge and the 12-in. mark aligned with the opposite edge. Then mark points at 3½ in. and 8½ in. Lines drawn through these points and parallel with the stock's edges will indicate the amount of stock to be removed to con-

vert the square section into an octagonal form.

How does this method work? The proportion of 3½ to 12 (or the easier to work with 7/24) relates to the geometry of an octagon almost exactly.

—J.H. Walker, Aspendale, Victoria, Australia

Drilling accurate holes

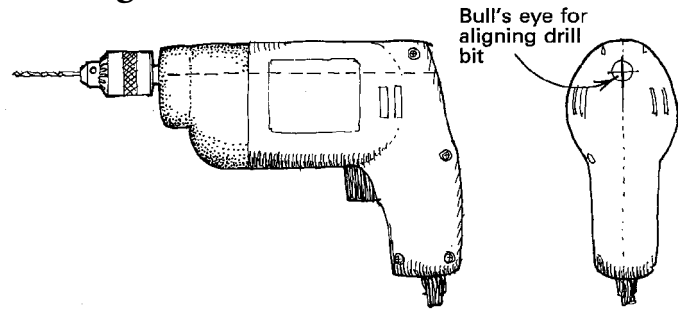

After drilling a couple of chair-seat spindle holes at the wrong angle, I came up with a simple solution to improve my angle alignment accuracy. Using a flexible steel rule, I followed the line of the drill bit to the back of the drill, and with a fine-point felt marker, drew a horizontal axis line across the case seam at the center of the back. This gives me a perfect bull's eye to line up the desired angle.

—Bruce A Goddard, Kennedy, N.Y.

Methods of Work buys readers' tips, jigs and tricks. Send details, sketches (we'll redraw them) and photos to Methods, Fine Woodworking, PO Box 5506, Newtown, Conn. 06470-5506. We'll return only those contributions that include an SASE.

Modified C-clamps

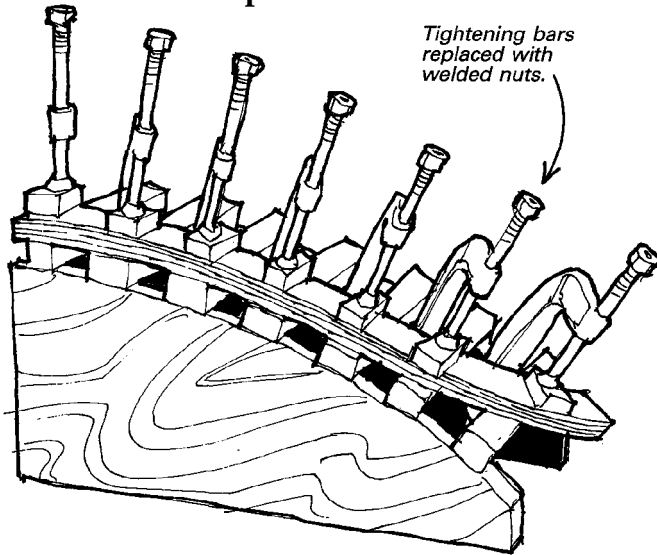

Almost all C-clamps have sliding bars through the end of the screw for tightening. But when you have to use several clamps close together, as you do when gluing laminations to a curved form, for example, these bars get in the way. On a recent project, I finally got annoyed with the interfering handles, so I removed the tightening bars and welded nuts to the ends of the clamp's screws. Now I can easily take up the slack by twisting the screws with my thumb and forefinger and then give each a final tightening with a short-handled socket wrench. As an added bonus, the clamps stack up neatly on a storage post.

—Jack Jerome, Nokomis, Fla.

Quick tip: Apply a thin coat of nail polish to the cutting edge of chisels and plane irons before sharpening. The wear pattern in the color will give you direct feedback about the sharpening angle and honing progress. —Howard E. Moody, Upper Jay, NY.

Chisel sharpening

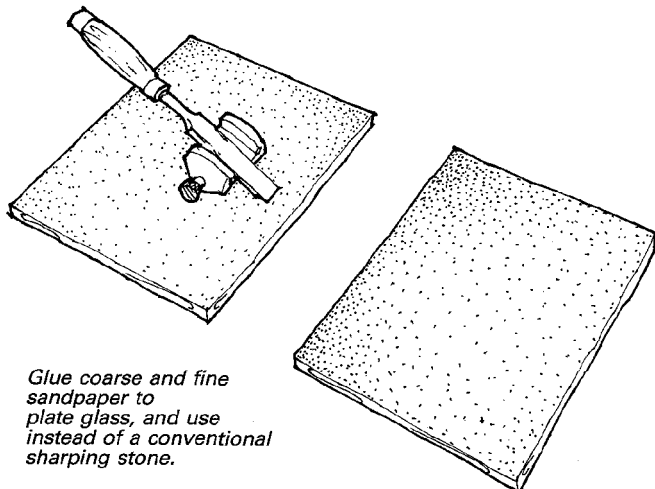

Glue coarse and fine sandpaper to plate glass, and use instead of a conventional sharpening stone.

Here's how to produce a really sharp edge on a chisel or plane iron quickly and without the typical problems of holding the tool by hand on a grinder, such as overheating an edge or dealing with unevenly worn sharpening stones. Attach full sheets of 150-grit and 600-grit sandpaper to 1/4-in.-thick plate glass with spray adhesive. Place your chisel in a wheeled sharpening guide, and begin with the 150-grit. Spray a little water as a lubricant, and go to work. You will quickly produce a flat bevel, even on

the widest chisel. Now go to the 600-grit, again with water. The sharpening guide ensures that you will get exactly the same angle on the subsequent, finer honing, and in no time, you'll have a sharpened edge that almost looks polished. Finer paper up to 2000-grit is available if you want to polish further.

This method also works for truing the bottom of a plane or the flat side of a chisel. —Thomas R. Schruck, Minneapolis, Minn.

Another way to make a five-pointed star

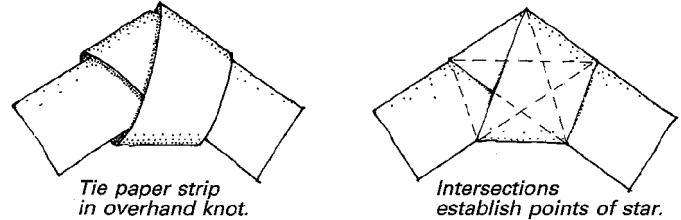

Tie paper strip in overhand knot.

Intersections establish points of star.

I've read about several methods for laying out pentagons or five-pointed stars based on algebra or trigonometry, like the one put forth by Daniel Bass in *FWW* #89. My method for laying out a five-pointed star requires neither calculator, compass, protractor, formulas nor hard-to-remember constructions. Take a strip of paper as wide as the distance between star points, and carefully tie a simple overhand knot. Thin but strong paper works best. Resist the temptation to flatten and create the paper until you have removed all the slack. When the strip knot is tight and flattened, you have created a perfect pentagon pattern, as shown in the sketch above. You can scale the pattern up or down to whatever size pentagon you need or connect the intersections of your paper knot to draw a star. —Ralph Koebke, Fremont, Ind.

Auto-jack bar clamps

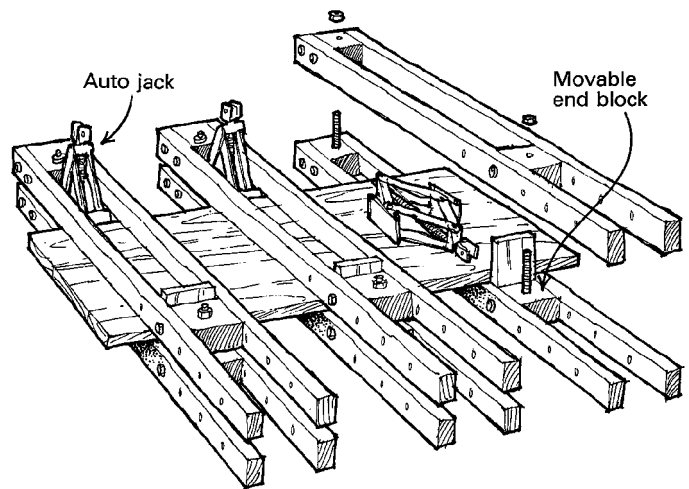

Here's a way to make low-tech wooden bar clamps for gluing up panels, tabletops and the like. The inexpensive clamps, which utilize salvaged scissor-style auto jacks for the main component, adjust to any thickness of stock and automatically align the stock being glued. Also, the parts are bolted instead of glued together, so you can easily replace any damaged component.

To build the clamps, select 1-in. or thicker dense hardwood, and make the various parts as shown in the sketch. To use the clamps, first bolt the movable end blocks into the appropriate hole that correlates to the size panel you're gluing up. Then place the work on the lower tier of clamps and apply glue to the edges. Next slide on the upper parts of the clamps and hand-tighten the nuts to align the boards being glued up. Last of all, insert and tighten the car jacks to put edge pressure on the glued lumber.

—Koji Katsuragi, Kumamoto, Japan

Elastic pantograph

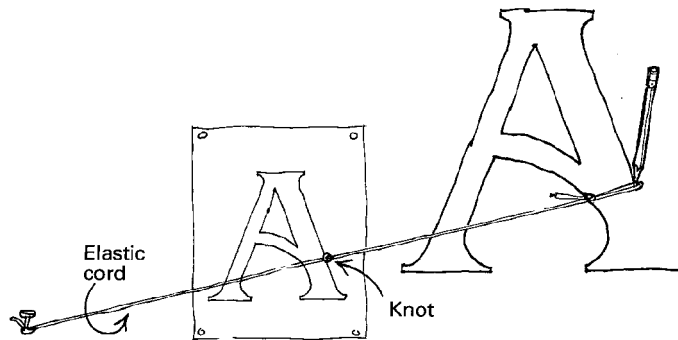

I use this elastic-cord pantograph to transfer designs from paper to wood for carving. You can buy small diameter elastic cord at mountaineering shops, or rob the shock cord from the inside of hollow tent poles. Set up the cord, nail, wood, paper and pencil as shown in the diagram. Keep tension on the cord at all times, and move the pencil so the knot in the cord follows the design on the paper to trace an enlarged version of the design.

The degree of enlargement can be varied by changing the position of the knot. The closer the knot is to the nail, the bigger the proportion of enlargement.

—Bob Cromwell, Royalston, Mass.

Quick tip: To ensure your suddenly acquired stock of free green wood doesn't crack or check before you get it on the lathe, keep it submerged in a tub of water. Wood can be preserved in this manner almost indefinitely.

—Earl R. Rice, Augusta, Ga.

Cutting toy wheels on the bandsaw

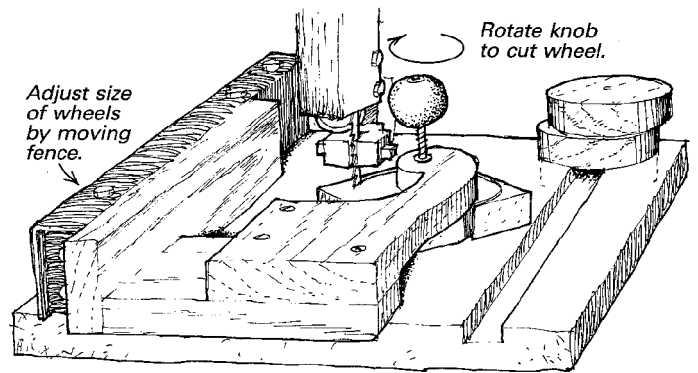

The toy wheel cutting fixture I made for my Craftsman 12-in. bandsaw, attaches to the saw's fence with two screws. The fixture will cut out wheels ranging in diameter from 2 in. to 6 in. from $\frac{3}{4}$ -in. stock. You can cut wheels from thicker stock by adding a spacer. Bandsawn wheels have advantages over those produced by a hole-saw: The diameter selection is infinite, and because there is no hole through the wheel, there's more flexibility in mounting.

To use the fixture, I first precut the wheel blanks about $\frac{1}{2}$ -in. larger than the finished wheel. Then I slide the blank into the fixture with the center of one edge pressed lightly against the blade. I insert the pivot-knob screw into the spacer hole and screw the knob into the blank about one or two turns. The spacer hole is lined with a piece of tubing, so it won't become enlarged. Then I turn on the saw and rotate the block into the blade by turning the knob.

—E. T. McCord, Tucson, Ariz.

Tablesawn coves

I've seen several articles lately describing how to cut coves by pushing the workpiece across the tablesaw at an angle using temporary guide fences. The trouble is they're all doing it the same way it was done 50 years ago—scratching rough coves $\frac{1}{16}$ in. at a time with sawblades that were designed to cut kerfs.

To cut smooth coves to full depth in one pass, simply replace the sawblade with a molding head fitted with radiused cutters. The molding head removes fluffy shavings—evidence that it is cutting, as opposed to whatever a sawblade does when the work is fed into it from the side. A second cut of $\frac{1}{32}$ -in. will produce a finish comparable to that of a commercially milled molding. Of course, for a very deep cove, you can remove the waste in more than one pass.

Cove-cutting is not for unsupervised beginners. Beyond the generally accepted safe work habits, I recommend a few special measures. First, use a snug-fitting insert, making sure it is flush to the saw's surface. Make sure the angled fence is held securely in place, and the cutters are sharp and clean. Apply wax to both table and guides so that the work will slide easily. Do not use push sticks—push blocks of the type available from Sears are much better for this operation. You can make your own push blocks from the rubber-padded floats used for finishing concrete. Last, feed the stock at a slow, steady rate. You will be delighted with the results. —Tom Rose, Los Angeles, Cal.

Quick tip: Storage boxes used to hold $5\frac{1}{4}$ -in. computer diskettes (also available in $3\frac{1}{2}$ - and 8-in. sizes) make great organizers for 5-in. sanding discs. Just label the boxes' dividers for different grits, backings and coatings.

—Andrew J. Lenhart, Royal Oak, Mich.

High-chair-latching mechanism

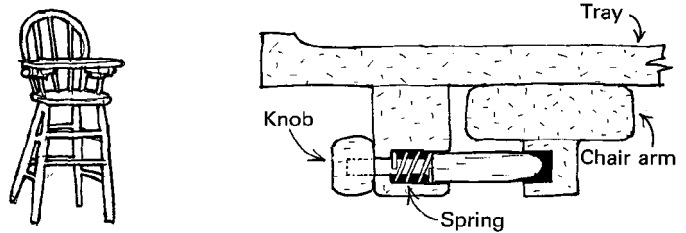

After my son, Corey, was born, I wanted to build a high chair for him, but I didn't like the hardware that was available for attaching the removable tray to the chair.

The replacement I designed is basically a modified bullet catch. But instead of installing the bullet pin in a blind hole, I turned the shank of the bullet longer and thinner, extended it out the back through a smaller hole and glued on a small knob. The spring-loaded bullet pin engages a small block, which is permanently attached to the chair under the arm. The block is all that's visible when the tray is removed. This design has lasted through three children without any problems.

—Ben Troxell, San Jose, Cal.

Quick tip: When sanding small parts that can't be gripped with the fingers take a technique from the lapidary. Put a dollop of hot-melt glue on the back of the part and stick it on the end of a dowel. To remove the dowel, place the assembly in the freezer for a few minutes—the part will pop right off. This technique also works well for polishing small metal parts on a buffing wheel.

—Paul Marshall, Apache Junction, Ariz.

Hammer hanger

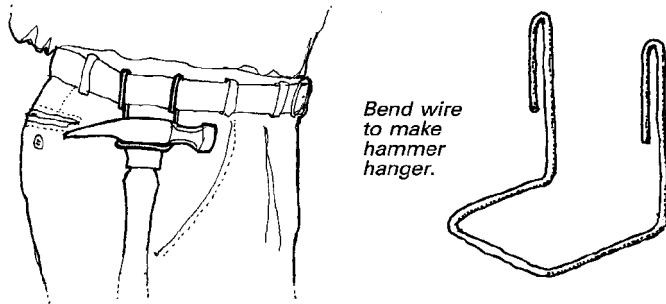

Forty-plus years ago, when I was an apprentice, all tradesmen wore overalls. An old-timer showed me the trick of inserting the hammer's handle into the side opening at the hip below the buttons. Always handy, the hammer's handle hangs along your leg without interfering with movement. Years later, after the overalls era had passed and leather aprons appeared, I found the hammer loops on the aprons were often in the wrong place for me. So I bent up a piece of $\frac{3}{16}$ -in. wire into a hammer hanger like the one shown above. The hanger slides over your belt to any position you prefer—in my case to the spot where I carried my hammer years ago. Most importantly, you can drop the hammer in the hanger without looking and retrieve it just as easily.

—Jerome Jahnke, Milwaukee, Wisc.

Quick tip: This simple idea has saved me hours of work when trying to trim dowel plugs flush with the surface. Simply tape a double layer of masking tape along the length of each side of the sole of a low-angled block plane. Now take a fine cut with a

sharp blade. The plane rides just off the surface of the wood and neatly cuts the plug flush. A quick sanding finishes the job.

—Bob Gleason, Hilo, Hawaii.

Magnetic chisel-storage rack

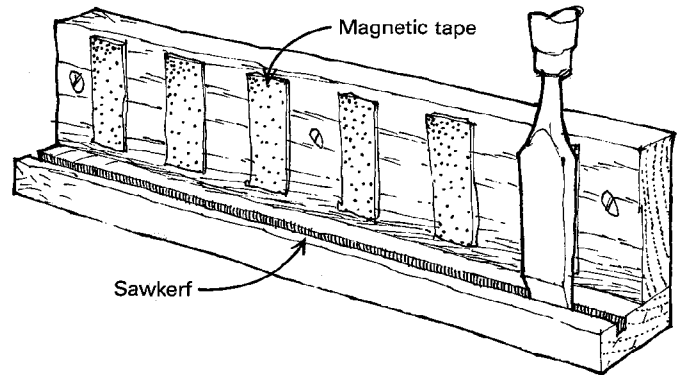

I have found this simple-to-make storage rack extremely useful for chisels and turning tools. The sawkerf in the ledge both secures the blade of the tool and protects the finely honed cutting edge. Make the back board thick enough so that the handles won't hit the wall and prevent the blades from resting against the magnetic tape.

The self-adhesive magnetic tape is generally available at hardware and novelty stores. The tools can be removed and replaced easily but won't fall off by themselves; mine even stayed in place through a small earthquake.

—Roger Walker, Orleans, Ont. Canada

Combination square improvement

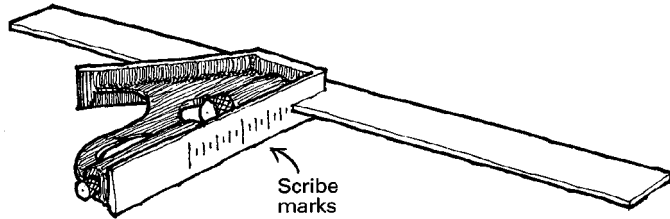

I scribed marks at $\frac{1}{8}$ -in. increments on the body of my combination square to help in transferring measurements. The marks are especially useful when laying out story sticks for cabinets. I didn't scribe the numbers, and $\frac{1}{16}$ -in. increments are easy enough to eyeball when needed.

—Tom Rodriguez, Westfield, Mass.

Improved miter gauge runner

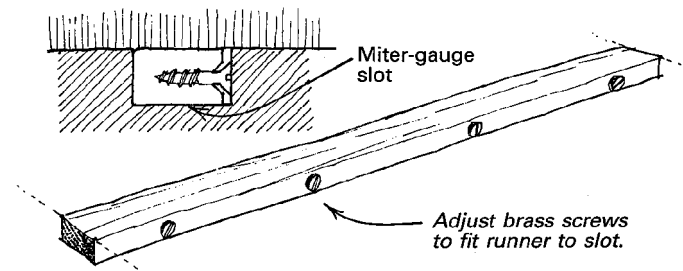

Over the years, I've seen many plans for homemade jigs that utilize a hardwood runner that fits in the miter-gauge slot. But, because wood shrinks and expands depending on the humidity, the run-

ner's fit and, hence, the jig's accuracy will vary. To correct the problem, cut the runner a bit undersize so that it is loose in the slot. Then install four $\frac{1}{2}$ -in.-long brass screws in countersunk holes along one edge of the runner. You can adjust the screws to get a perfect fit, regardless of the humidity. The brass screws won't wear the sides of the slot and are easily replaced if they wear out.

—Larry Loo, M.D., Clovis, Cal.

Sawhorse holdfast

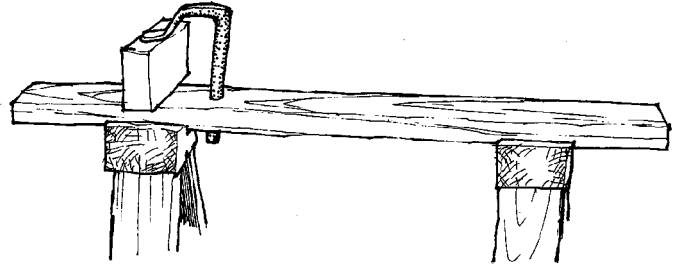

Holdfast clamps are simple, inexpensive, quick to apply and just as quick to release. I keep one in my toolbox for use with my sawhorse in which I've drilled a few strategically placed holes. The clamp is especially valuable when I have to use both hands in a cutting operation and can't let the workpiece slip around.

—Don Rosati, Easton, Conn.

Methods of Work buys readers' tips, jigs and tricks. Send details, sketches (we'll redraw them) and photos to Methods, Fine Woodworking, PO Box 5506, Newtown, Conn. 06470-5506. We'll return only those contributions that include an SASE.

Quick router setup

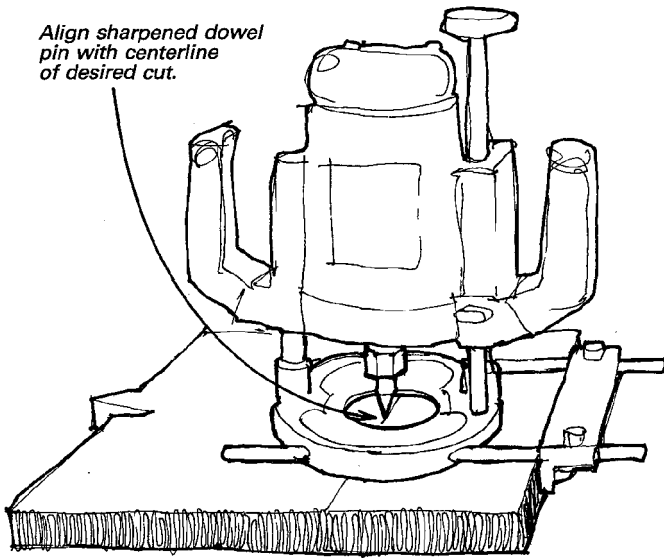

Here is a quick procedure for setting the fence on your router. Grind a center point on the end of a steel dowel pin that fits the chuck of your router. You can grind the point by chucking the pin in an electric hand drill, turning on the drill and holding it against a running bench grinder. To use the pointed pin, insert it in the router collet, and place the pin right on the centerline of the cut. Then set the fence, replace the pin with the bit, and you're ready to go.

—Jeff Trentini, La Mirada, Calif.

Center finder

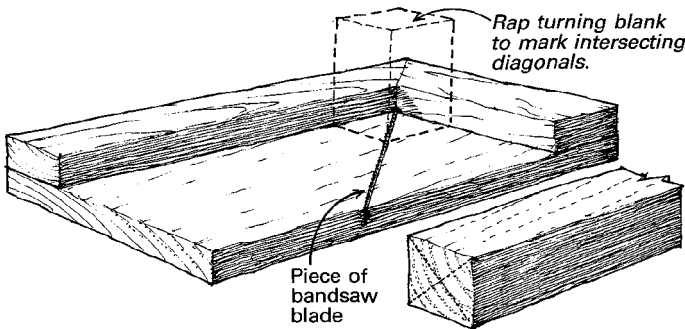

Faced with making several dozen spindles for a cradle, I put together this easy-to-use center finder. To make the device, first cut a shallow kerf at a 45° angle in a 3-in. by 5-in. block of hardwood with a miter box and a dovetail saw. Press a snapped-off length of a fine-tooth bandsaw blade into the kerf so that the teeth stand out about 1/8-in. Then attach wood guide strips along two edges of the base, as shown above.

To use the finder, clamp the assembly to your workbench and slide the end of the blank to be marked into the corner where the guide strips meet. Rap the blank with a mallet to put a diagonal mark across its end. Then turn the blank 90° and rap again. Flip the blank over and repeat the process to mark the other end. This center finder will accept squares or cylinders up to approximately 6 in. across.

—Nancy A. Franks, Essex Fells, N.J.

Quick tip: When you need a precision temporary shim or feeler gauge, try the non-fluted end of a twist drill. My set ranges from 1/16 in. to 1/4 in. in increments of 1/64 in. I recently used a pair of 3/32 in. bits to align a flush-mount drawer during its installation.

—Tom Hazelleaf, Seal Beach, Calif.

Marking turning-stock centers

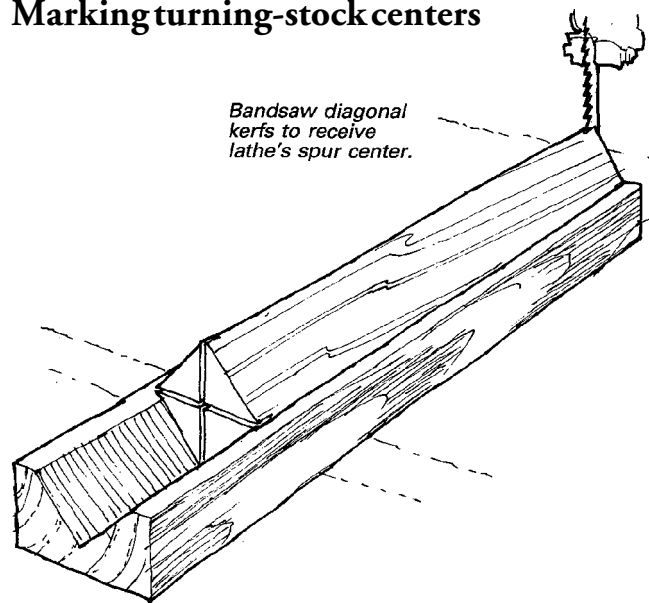

The fixture above marks the centers of turning stock and, at the same time, notches the stock to receive the spurs of your lathe's live center. To make the fixture, cut a 90° V into a scrap 2x4, place the squared workpiece in the V and feed it into your band-saw, so the blade cuts from corner to corner, about 1/4-in. deep. Turn the piece 90° and repeat. You can also use the jig to find the center of round stock. Just make sure the second cut is at a right angle to the first.

—Dean C. Westervelt, Acme, Pa.

Universal vise

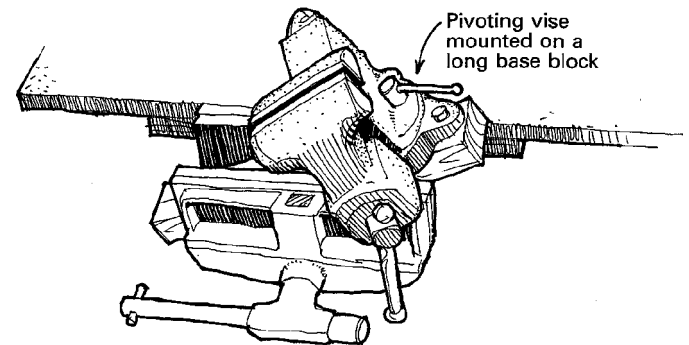

It's common for woodworkers to mount an engineer's vise on a block of wood, so it can be clamped in a woodworking vise and used to hold a piece of metal. To extend the clamping range of the vise-in-a-vise concept, choose a small engineering vise with a pivoting base, and bolt it to a 2-in.-square hardwood post that extends about 5 in. beyond the vise. This allows you to vary the position of the post in the carpenter's vise to obtain an almost unlimited number of clamping angles.

—A. D. Goode, Sapphire, NSW, Australia

Routed scarf joint

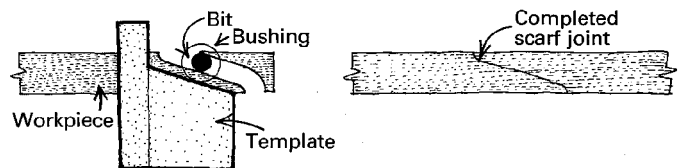

When I needed to make several scarf joints for a cover board in a boatbuilding project, I used a router and template to cut the

joint's profile. The challenge was to shape the template so that the inside curve would be identical to the outside curve. Finally, I hit on the idea of using a router bit with the same radius as the joint's curve and a template bushing with twice the radius. With my router set up this way, all I needed for a template was a simple glued-up block with three straight line edges.

—Robert L. Thompson, New Hampton, N.H.

Masking for window trim

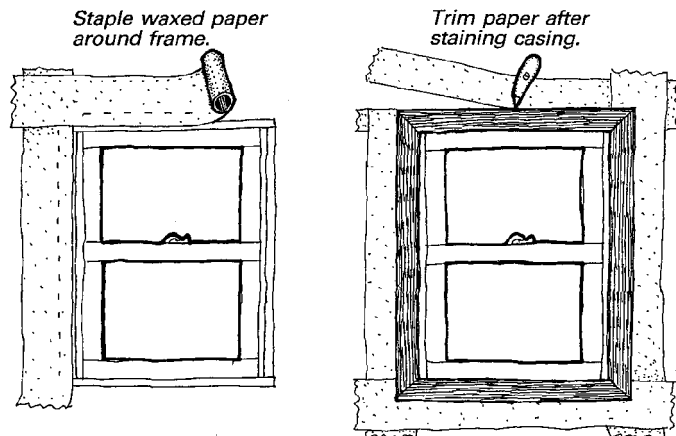

Here's a simple masking procedure that dramatically speeds the process of finishing door and window trim. Cut a roll of regular waxed paper into thirds, and, before installing the casing, staple lengths of the narrow waxed paper around the frame. Now in-

stall the trim and stain away. The paper will protect the surrounding sheetrock, and if you also have to paint the walls, just fold the waxed paper down to mask the stained casing from the wet paint. When the paint is dry, simply trim off the exposed waxed paper with a razor knife.

—Richard H. Larsen, Racine, Wisc.

Sawblade indexing head

When an impromptu indexing head is needed for fluting or other routing on the lathe, use a circular sawblade. Divide 360° by the number of teeth to determine how many degrees each tooth represents. A 48-tooth blade, for example, represents 7.5° per tooth, which is particularly useful because you can easily find common settings like 30° , 45° and 90° . To use the indexing blade, fasten it to the workpiece and mount the assembly between centers. Then you can rotate the assembly the desired number of degrees, and place a pin in the appropriate tooth gullet to lock the workpiece in position.

—Boyd K. Ferrell, Blackduck, Minn.

Shop uses for adhesive transfer tape

I discovered the Scotch adhesive-transfer tape I use to mount papers and mat boards is also handy in the shop. This tape has a paper backing that peels off, leaving only a layer of adhesive. Available in $\frac{1}{2}$ -in. and $\frac{3}{4}$ -in. widths, it is designed to be used in a trigger-operated gun but can also be used straight off the roll. I find this tape useful for tacking wood together for sawing, routing or sanding, and the adhesive doesn't affect any of those operations. Used in the gun, transfer tape is much faster than double-faced tape, and you can put the right amount exactly where you want it. The adhesive can be removed by rubbing it with your finger

or by laying masking tape over it and lifting. The gun (Scotch ATG-752) and the transfer tape (#942) are available at art- and framing-supply stores. —*Frank Valenichis, Hollywood, Fla.*

Quick tip: Keep the sticky side of the masking tape out when wrapping folded bandsaw blades to avoid any glue residue on the blades later. —*Robert M. Vaughan, Roanoke, Va.*

Constant-pressure hold-in

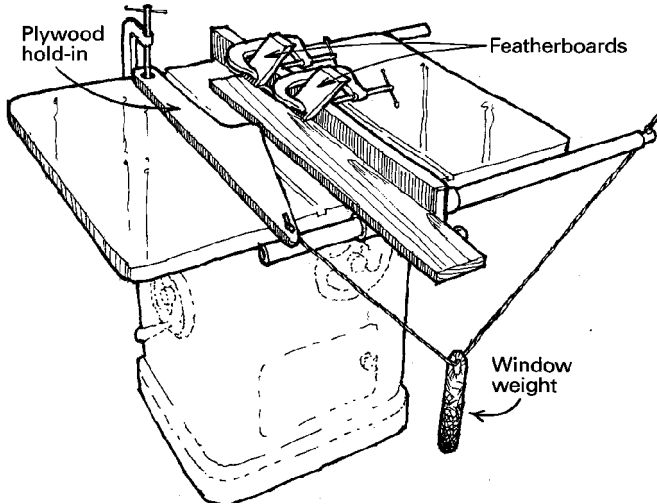

One day, while working in the shop alone, I found I needed an extra hand to rip random-width $\frac{3}{4}$ -in. stock into square molding

blanks. To rip these long pieces safely, I built a hold-in from a scrap piece of plywood and an old window weight, as shown in the sketch below left. In operation, the hold-in pivots open and applies pressure just in front of the blade as I push the workpiece into it. The window weight, which hangs on twine tied to the hold-in and the end of the rip-fence bar, provides the constant pressure needed to keep the workpiece against the fence. While ripping, I also add two featherboards, one clamped to the rip fence in front of the blade and one clamped behind it. Using this method, I have ripped many linear feet of irregular-sized pieces by myself and still have all 10 of my fingers.

—*John Spurlock, Houston, Texas*

Quick tip: For starting screws in tight corners and other hard-to-reach locations, attach the screw to the screwdriver blade with a dab of rubber cement. —*Howard E. Moody, Upper Jay, N.Y.*

Stops for small drawers

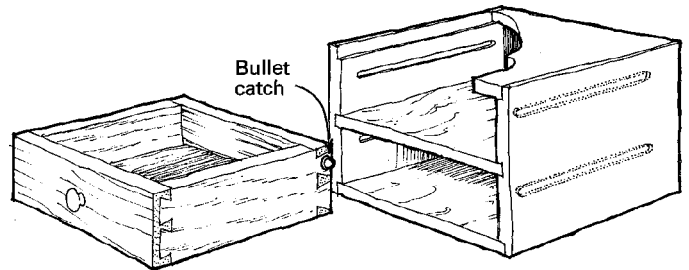

To keep small drawers or trays from falling out, install a bullet catch in the back of each drawer side, and rout a groove in the

side of the drawer frame. The spring-loaded bullet catch will stop the drawer at the end of its normal travel. But when needed, an extra tug will remove the drawer from the frame.

—Mark Stebbins, Palm Bay, Fla.

Keyed miter joints

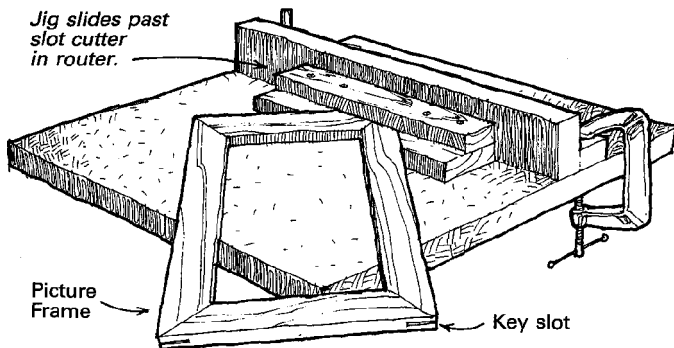

I like to reinforce the miter joints in my picture frames by adding a contrasting key after the glue in the joint has set. The usual method of cutting the key slot is with a tablesaw and a vertical 45° jig riding on the fence, but I find it easier and safer to make the cut on the router table with a slot-cutting bit. The jig, shown in the sketch above, can be made in just a few minutes and has the advantage of enclosing the spinning bit throughout the operation. The resulting slot has a flat bottom and is uniform in width. Inexpensive bits are available to cut slots as narrow as 1/16-in., which looks better on a small frame than the 1/8-in. slot produced by a tablesaw's blade. On larger frames, I cut two slots

by setting the bit a little below the centerline, cutting the first slot and then flipping the frame over for a second pass.

—Paul Davis, Lake Stevens, Wash.

Quick Tip: If you have to use an edge tool for a final detail after a piece has been sanded, give the wood a good blast of compressed air. The air removes most residual abrasive granules that would otherwise quickly dull a scraper or lathe tool.

—Robert M. Vaughan, Roanoke, Va.

Go-bars for clamping

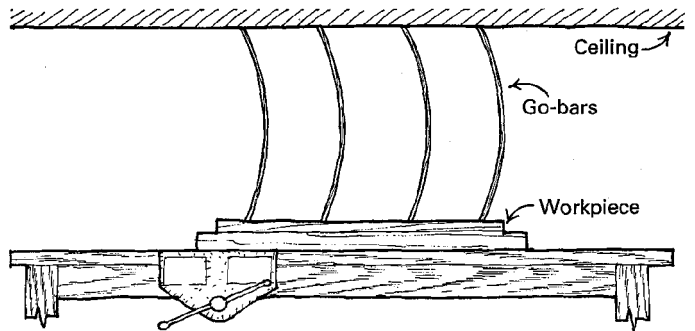

I first learned about go-bars during a visit to the shop of William Dowd, a harpsichord builder. A go-bar is simply a thin strip of wood flexed by hand into a bow shape and inserted between a fixed surface, such as a ceiling, and the surface of a workpiece to be clamped. Harpsichord makers use go-bars for gluing the soundboard of their instrument into the carcass because no or-

dinary kind of clamp can be brought easily to bear on the work. But go-bars can be applied to a much broader range of clamping problems. They are not only simpler and less expensive than other clamps but also much easier and faster to set.

To make go-bars, start with straight-grain wood. I've used $\frac{3}{4}$ in.-thick fir flooring sawn into $\frac{1}{2}$ -in.-wide strips for 39-in.-long go-bars. Experiment with your own wood-and-clamping conditions to get the dimensions right. Cut the bars about 2 or 3 percent longer than the distance between the work surface and the fixed surface. This will cause the bars to bow out about a fifth of their length, which should feel about right.

—Abijah Reed, Newton Centre, Mass.

Tapping screw holes

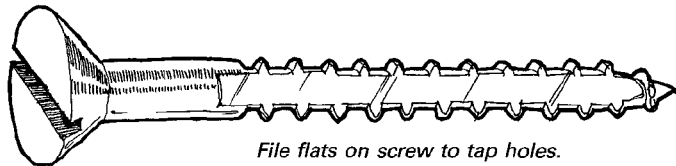

File flats on screw to tap holes.

When driving screws into hardwood, it is easy to snap off the screw in the hole or gall up the screw slot. To reduce these problems, tap the hole prior to driving the screw. Make a tap by filing or grinding two opposing flats down the length of a screw, as shown in the sketch above.

—Don Clemens, The Colony, Texas

Two ways to clean spray-can nozzles

You can clean a clogged nozzle from an aerosol paint can by temporarily moving the nozzle to a can of engine starting fluid

and squirting some of the fluid through it. The ether and solvent in the starting fluid will thoroughly clean the nozzle.

—Vic Hulley, Penticton, B.C. Canada

Rather than wasting propellant gas to clear the nozzle jets of spray-paint cans, remove the nozzle head and store it in an appropriate solvent, like acetone. I find a plastic 35mm film container ideal for the purpose.

—James Sterling, Concord, Mass.

Quick tip: When machine-sanding with fine grades of sandpaper, apply masking tape to the exposed edges on the back of the paper to protect them from tearing. This allows much longer use of the thinner, more delicately backed sandpapers.

—Dan Morgan, El Sobrante, Calif.

Truing up a router base

Many router bases are almost, but not quite, concentric with the collet center. This has the undesirable effect of varying the distance between the fence and the bit or slightly changing the depth of cut when the router is rotated. You can true up a base by first mounting a short length of straight steel rod in the router. Then drill a rod-sized hole in a flat block of wood, so you can pivot the router in the block with the router base's edge against a disc sander. Clamp the block to the disk-sander table (set at 90°); then rotate the router to sand the base round.

—Bill Webster, Chillicothe, Ill.

Methods of Work buys readers' tips, jigs and tricks. Send details, sketches (we'll redraw them) and photos to Methods, Fine Woodworking, PO Box 5506, Newtown, Conn. 06470-5506. We'll return only those contributions that include an SASE.

Unlocking drill-press depth-stop nuts

Drill-press depth stops that consist of two nuts and a threaded rod have an annoying habit of locking together. Although tightened by just finger and thumb pressure, they inexplicably resist the same or greater pressure to loosen them. I solved this problem by inserting a red fiber washer between the nuts. Such washers, used in fuel lines and carburetors, are easily obtained in auto-parts stores.

—Kenneth Wells, Portsmouth, England

T-guide for cutting sliding dovetails

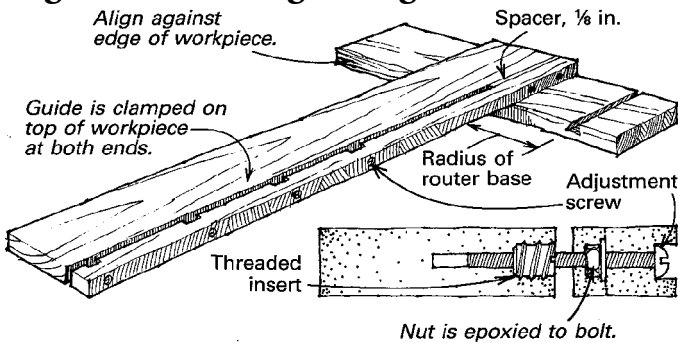

This T-guide adjusts so you can rout a sliding dovetail slot that is slightly wider at one end, such as for the rear of bookcase ends. The tapered slot allows easier insertion of the dovetail cleat but does not compromise the integrity of the joint. Construction of the guide is straightforward, as shown above. For the adjustment action, I installed 1/4-in. machine bolts and threaded inserts every 6 in. along the arm. Nuts epoxied to the screw threads provide leverage for moving the arm in and out.

To rout a tapered dovetail, I clamp the guide to the panel at both ends, making sure the head of the guide is at the end of the panel where the joint will be the tightest. After making one pass with the router to cut a uniform-width dovetail slot, I turn the adjustment screws to move the flexible part of the guide arm out a bit—just a quarter turn or so at the far end is usually enough. Then I make another pass with the router to produce a slot that is slightly wider at one end. To complete the joint, I cut the dovetail on the cleat in the standard way using a router table.

—H. Wesley Phillips, Greer, S.C.

Making miniature dowels

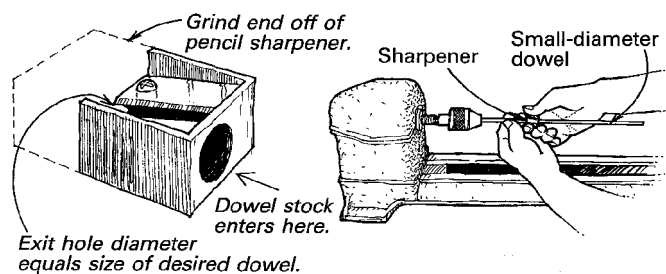

As an amateur model furniture maker, I often need small dowels. To make mini-dowels, I use a modified twist-type pencil sharpener. I grind the small end (blade and all) off the sharpener so that the size of the exit hole corresponds to the diameter of the dowel I need. To use the tool, I chuck square stock that's small enough to enter the sharpener's wide end (mouth), and with my lathe at its lowest speed, I just run the modified sharpener down the stock. This device works like the old rounding planes that were popular in the hand-tool era. As an alternative, you could also tighten the sharpener in a small vise, and with the stock chucked into a hand drill, carefully push the spinning blank through the sharpener.

—Louis J. Lauler, Churt, England

Bench hold fast

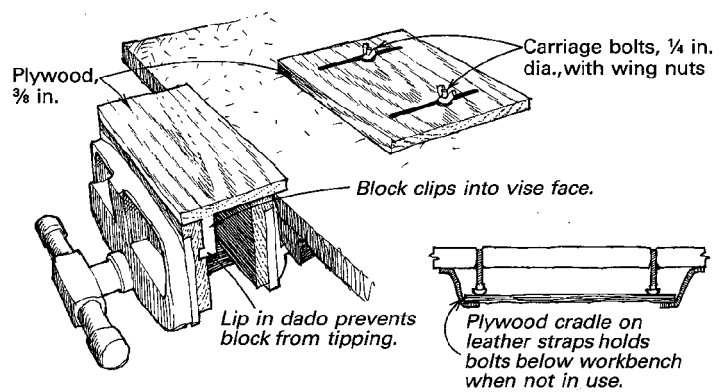

My rather restricted workshop/garage does not allow me to add a tail vise to my bench. So I designed this simple hold fast to secure long pieces of wood while I'm planing them on the benchtop. The device consists of two parts, a hardwood block that clips into the vise face and an adjustable fence. Both parts can be easily removed to return the bench to its original usage. I added a leather and plywood cradle below the bench to hold the carriage bolts when they are not needed, but the cradle allows the bolts to be pushed up easily when attaching the fence. The device provides a considerable grip and restrains most workpieces.

—D. A. Kennedy, Rugby, England

Making wooden door handles

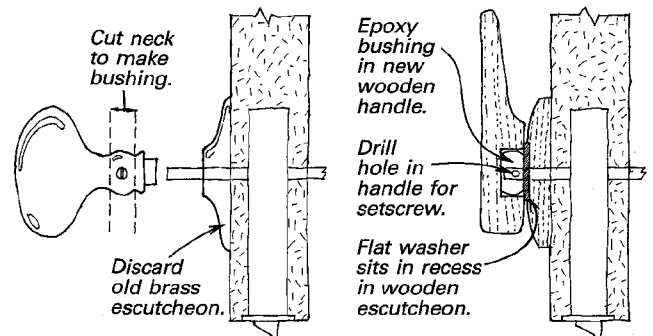

Inspired by pictures that show the variety of wooden door handles in Sam Maloof's house, I came up with a method that enables me to add new wooden handles to original door hardware.

First, throw away your door's original stamped brass rose (escutcheon), and saw the neck of the doorknob, as shown above, to produce a brass bushing about 1/2 in. thick. Epoxy this bushing in a flat-bottomed hole in the back of the new wooden handle. Drill a hole in the bottom side of the handle to align with the setscrew hole in the bushing. Don't make the handle so heavy or off-center that its weight withdraws the latch bolt. Also, the handle must turn 90° to fully withdraw the latch, so make sure there is enough clearance (for the handle and your hand) between the handle's end and the door casing. Next, make a wooden escutcheon to replace the brass rose. Counterbore a shallow recess in the face of the new escutcheon, and epoxy a washer that sits just proud of the face. Drill the washer the same size as the shaft if necessary. The washer provides a bearing for the shaft as well as a wear surface for the handle to turn on.

—Nelson Hicks, Milford, Conn.

Quick tip: Put paste wax on the threads of the glue bottle to keep glue from sticking and making the bottle hard to open.

—Tom Schrunck, Minneapolis, Minn.

Finishing bowl bottoms

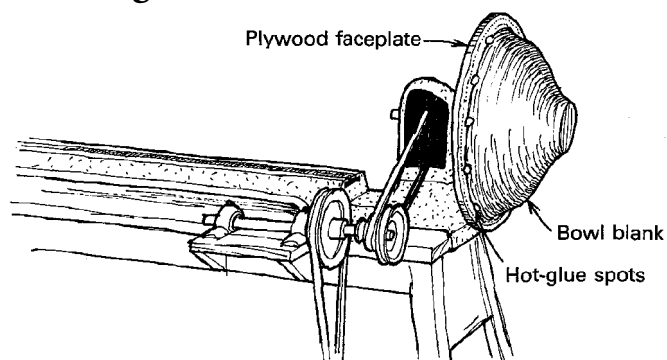

This simple but effective method for finishing bowl bottoms utilizes a plywood mounting plate and hot-melt glue. To make the mounting plate, I attach a plywood disc to a 6-in. faceplate, true it and, with my parting tool, score it in concentric rings about $\frac{3}{16}$ in. apart. I turn the inside of the bowl on a standard faceplate in a conventional way, and after I've turned, sanded and finished the inside, I part the bowl from the lathe and apply mineral oil to the rim. Centering the bowl face down on the plywood plate, I apply several penny-sized dabs of hot-melt glue around its circumference, each dab should be half on the mounting disc and half on the bowl rim. I use more dabs for larger bowls, fewer for smaller ones. For example, on a 16-in.-dia. bowl, I use about 10 spots of glue, one every 5 in. or so around the rim. Until you develop a feel for the strength of the glue, it's best to apply more dabs of glue rather than too few. I then screw the mounting plate on the lathe's arbor exposing the bottom of the bowl for turning, sanding and finishing.

When these operations are done, I pry the bowl loose from the glue spots. The mineral oil minimizes any glue sticking to the rim, although I sometimes have to use the corner of a flat chisel to lift the glue off the plywood mounting plate. I use this hot-melt glue technique in all my woodturning, ranging from small wine goblets to burl bowls over 3 ft. dia, and I've been consistently pleased with the results. —Maurice Gamblin, Perth-Andover, N.B., Canada

Boring cribbage-board holes revisited

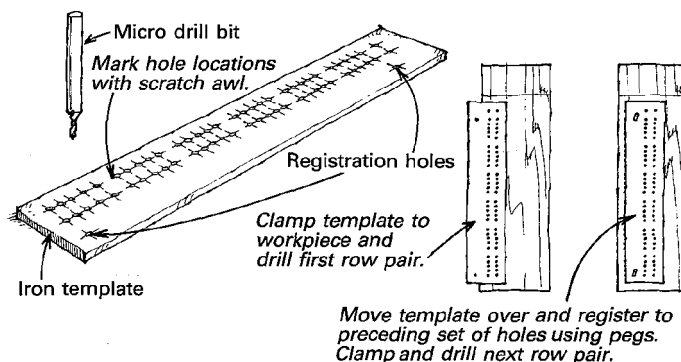

Here's a cribbage-board drilling method that's more straightforward than the one offered by Charles Whitney in *FWW* #92, p. 20. Start with a piece of $\frac{1}{8}$ -in.-thick flat iron long enough and wide enough to accommodate three rows of holes. Using a scratch awl, lay out lines on the iron that correspond to the locations of two rows of holes plus two registration holes, as shown above. Carefully center punch each line intersection. Drill the

holes with a drill press and a thick-shank bit specially designed for drilling small holes (about $\frac{7}{64}$ in.) in iron. Regular twist-drill bits have a tendency to bend out of line.

Clamp the iron template to your cribbage blank, and drill the first pair of rows. Unclamp the template, and move it over so that the registration holes are right over the two end holes on the previously drilled rows. Use pegs to register the template, and then reclamp and drill the second pair of rows. Repeat for the third row pair.

—M. E. Woodbury, Orangevale, Calif.

Micro-adjustable auxiliary fence

Calibrate adjustment graduations based on slope of slide.

Fixed side of jig presses into miter-gauge slot (or screws to rip fence).

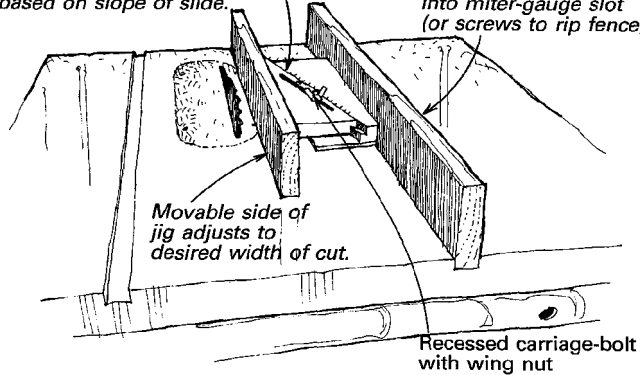

In the past when I wanted to adjust the width of a cut just a hair, I usually just bumped the tablesaw fence with my hand—with unpredictable results. To make my fence more precisely adjustable, I designed this auxiliary fence based on the principle of a

machinist's parallel. The jig produces accurate and repeatable results, is easy to build and is adaptable for all kinds of power saws and router tables. The jig's dimensions and hardware can be chosen to suit the machine and job requirements. I used a 9° angle on the slide. Although the half-dovetail slide is not required, it does help hold the parts together.

You can attach the auxiliary fence to a tablesaw in two ways: One, screw it to an existing rip fence, or two, press it into the miter-gauge slot, as shown. Although fastening the auxiliary fence to the rip fence gives a wide range of adjustment, the advantage of pressing the fence into the miter slot is that the unit can be removed while other work is being performed. Later, the auxiliary fence can be replaced with its setting undisturbed.

—Boyd Ewing, Depew, N.Y.

Spray finishing small items

Wooden plugs

Window screening stapled to pine frame.

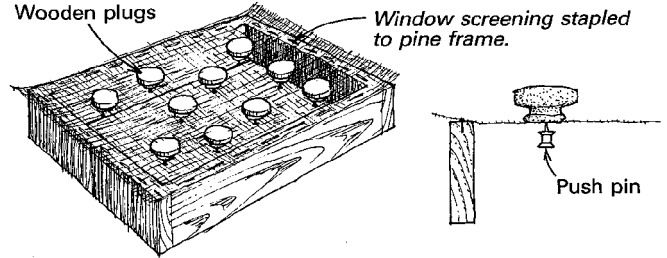

When I needed to finish a few dozen oak plugs for a new stair rail, I came up with a technique that solves most of the hassles of spray finishing small objects. I nailed together a scrap pine frame and snugged and stapled window screen across it. I then secured the plugs by inserting push pins through the screen into the bottom of

each plug. Air flow through the screen eliminates sprayer blow back, which, in turn, eliminates blobs of paint or finish from forming on the bottoms of the plugs. —James T. Jones, Jr., Fairfax, Va.

Concealed T-nuts

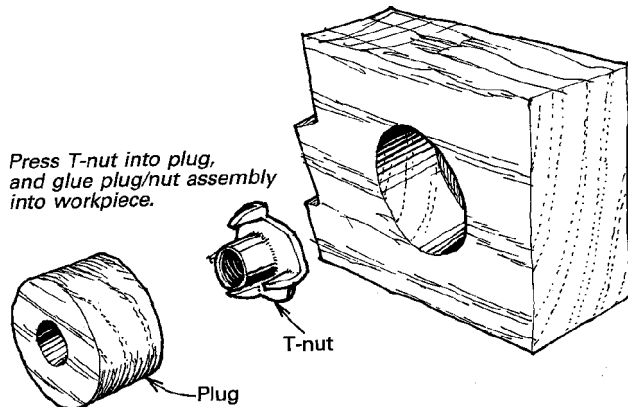

I use the following procedure to conceal T-nuts. Clamp a piece of stock in the drill press, and drill a hole to accept the T-nut shaft. Change the drill bit to a plug cutter just a bit larger than the T-nut flange, drill out the plug and cut it free. The result is a plug with a centered hole. Press the T-nut into the plug, and glue the plug/nut combination into a matching hole in the work.

I find T-nuts installed this way hold far better than brass threaded inserts, and they are less conspicuous and far less expensive. Three or four Forstner bits with matching plug cutters will cover most any application. —Terry Lavalley, Sitka, Alaska

Utility shelf for the tablesaw

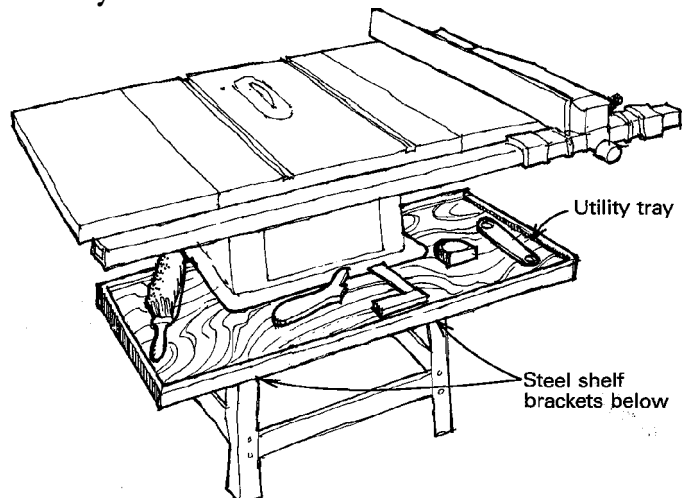

I find that a shelf built around the front of my tablesaw base is invaluable for keeping items (pencil, tape measure, miter gauge, bench brush, push sticks, blade wrench) handy. I built the shelf from $\frac{3}{4}$ -in. plywood, supported it with two steel shelf brackets and finished it with scraps of molding around the edge.

—Robert E. Brown, Watertown, NY.

Quick tip: On dark woods, such as walnut, go over your pencil line with chalk. The chalk will adhere to the wood, not to the graphite, resulting in a black-on-white line that's easy to see.

—E. S. Martin, Montrose, Ala.

Portable vise

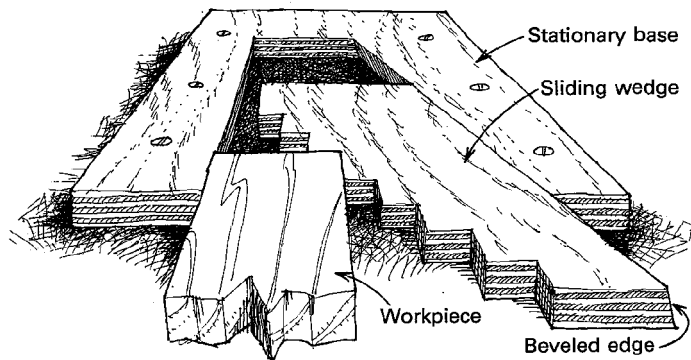

As a youngster, some 60 years ago, I often watched my father doing finish work using a light workbench, which he hauled from job to job. One of the attachments on that bench was a shopmade wooden vise, like the one shown in the drawing above. I reproduced the vise from memory and find it a versatile aid for holding stock both on edge for planing or flat for scraping.

To make the vise, I selected a scrap rectangle of $\frac{3}{4}$ -in. birch plywood, cut the sliding wedge from it with a beveled edge on the angled side, then notched the other side of the wedge at $\frac{1}{2}$ -in. intervals. I fasten work in the vise by finding the notch that fits and then tapping the wedge tightly into the jaws. A quick tap on the other end of the sliding wedge will loosen the workpiece. If I were making another, I would use $\frac{5}{8}$ -in. material so $\frac{3}{4}$ -in. stock would stand a bit proud of the vise and thus be easily dressed.

—Alfred S. White, Los Angeles, Calif.

Pipe-clamp rack

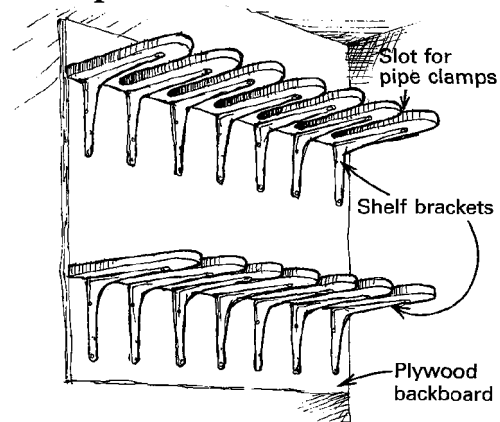

To hang pipe clamps in my shop, I made the brackets shown above from 11-in.-wide, $\frac{3}{4}$ -in.-thick plywood strips. Comb-like slots hold the clamps. Each slot is $1\frac{1}{8}$ in. wide and spaced 3 in. apart. Two sets of supports help the clamps hang straight. Each slot in the supports holds five clamps and accommodates either $\frac{1}{2}$ -in. or $\frac{3}{4}$ -in. pipe. Metal shelf brackets between each slot support the heavy clamps. Before mounting the rack, I covered the wall with plywood, so I wouldn't have to worry about hitting studs with the bracket screws.

—Robert C. Hendrick, DeLand, Fla.

Methods of Work buys readers' tips, jigs and tricks. Send details, sketches (we'll redraw them) and photos to Methods, Fine Woodworking, PO Box 5506, Newtown, Conn. 06470-5506. We'll return only those contributions that include an SASE.

Two-sided miter jig

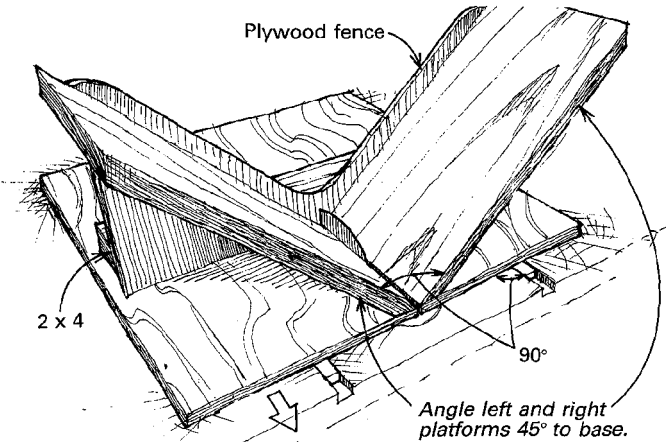

I'd like to thank Ken Wall, whose single-sided vertical miter jig (*FWW*#80, p. 16) inspired this double-sided version. The two-sided jig is even better because its accuracy is permanently established by the slanted platforms mounted 90° from each other, not by the angle between the blade and the jig, which could change. If you cut one of the mitered pieces on the left side of the jig and the other on the right, they're sure to form a 90° angle. The jig has proved excellent for small boxes, frames and most trim work.

To make the jig, start with a 20-in.-sq. plywood base. Attach hardwood runners to the underside to slide in the miter-gauge slots on either side of the blade. Mount the left platform to the base at a 45° angle. Then mount the right platform using a large framing square and shims to place it at a perfect 90° to the left platform. Install fences to the back of both platforms. The fences, along with the extra support of the long platforms (10 in. minimum), provide plenty of stability without having to use quick-action clamps. To keep the jig from being cut in two, leave plenty of room at the back of the base and install a 2x4 behind the fence. The 2x4 not only adds strength but also protects your thumbs from the blade. Make sure the front of the jig is square to the table's miter groove, so you can make 90° cuts against the jig. Using the jig's base like a miter gauge saves a lot of cranking the blade over and back.

—Dave Heffler, Lakeview, N.S., Canada

Quick-change disc sander

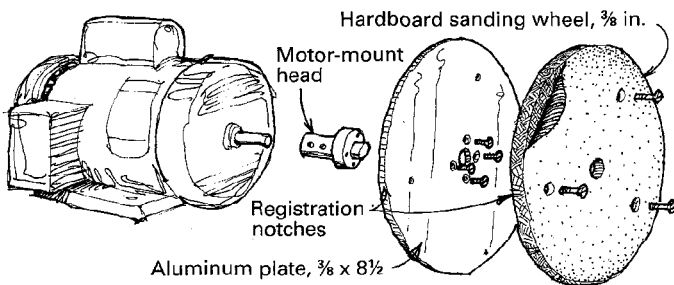

My work with burl boxes, which I hand shape and smooth on a disc sander, requires several progressively finer grit papers. Commercial sanders, aside from being expensive, make the job of changing grits a chore. So a machinist friend and I designed this disc sander with quick-change sanding wheels. My unit cost was about \$180, most of which was the motor. There are four parts to the machine: a 1½-HP, 1725-RPM motor, a head that slides onto the motor's shaft, an aluminum support plate and a selection of hardboard sanding wheels—one for each grit I need.

Commission a machinist to turn the head from a single piece of 2½-in.-dia. steel and to turn the ⅜-in.-thick aluminum support plate. Attach the plate to the head with machine screws, and then lock the whole unit onto the motor shaft with setscrews. The nipple on the head should extend through the plate about ⅜ in. or so to align the sanding wheels. Tap three equally spaced sanding-wheel mounting holes near the rim of the plate, and then file a registration notch near one of the screws. For the sanding wheels, use some ⅜-in. tempered hardboard or plywood, and bandsaw blanks about ¼ in. dia. larger than the finished size. Drill a ⅜-in.-dia. hole in the center of each wheel to accept the end of the head. From the back side, mark the three mounting holes, and then drill and countersink each hole on the front side.

Attach the sanding wheel to the support plate with flat-head screws, and with the motor running, shape the wheel with a belt sander until the wheel is perfectly round. Be sure to make a mating registration mark on the sanding wheel, so you can reinstall the wheel the same way every time. Mark the positions of the sanding-wheel mounting holes on the back of a sandpaper disc, and then cut screw access holes at these points. Adhere the disc to the wheel so the holes match, and you're ready to mount the sanding wheel on the aluminum plate. I have four wheels, one for each of the four grits I use. Changing wheels takes about a minute.

—Randolf Mateer, Detroit, Mich.

Adjustable stop for cutting tenons

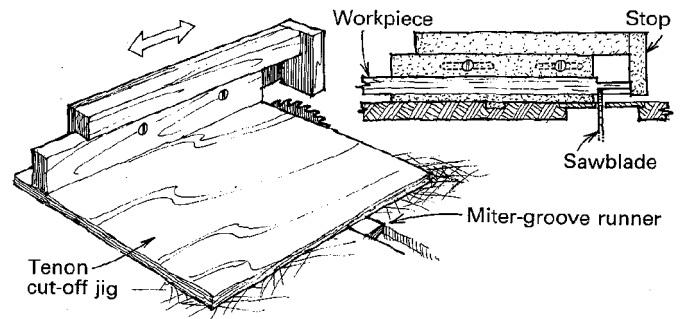

Here is a simple stop-fixture that I use to cut perfect tenon shoulders. The device, which is attached to my cut-off jig, prevents tenon-cheek waste from jamming against the fence, as often happens when using the rip fence as a stop. I just cut the workpiece to the right length, and the stop does the rest.

—John W. Williams, Bellevue, Wash.

A tablesaw clamp

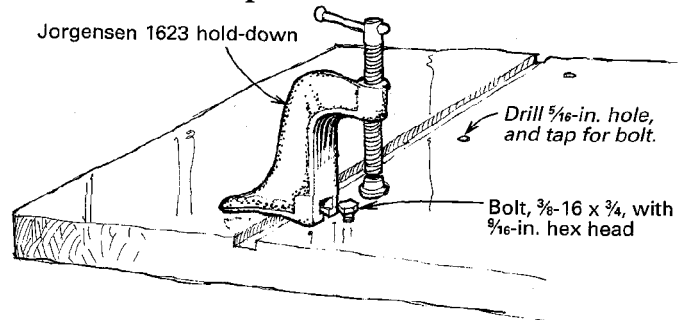

Because space has always been a concern in my small shop, the top of my tablesaw has often served second duty as a workbench. I found that by securing removable Jorgensen model 1623 hold-down clamps to the saw table, I could make the saw into a workbench without affecting its intended use. Four tapped holes in a saw table allow a surprisingly versatile choice

of clamping positions. I also use the holes to bolt a protective piece of plywood to the saw table for chisel work, to attach a router table and to secure featherboards and other tablesaw jigs and fixtures.

When locating the clamp's hole positions, be sure to avoid the cast reinforcing ribs in the table's underside. Center punch each hole location, and then drill with a sharp $\frac{1}{16}$ -in. bit. When tapping the $\frac{3}{8}$ -in. bolt threads, rotate the tap a half turn in, then back it out a quarter turn, and so on. This action will break up the chips and keep the tap cutting freely. Don't force the tap, and when you're done, chamfer the hole to keep any sharp edges from scratching your workpieces. Screw a $\frac{3}{8}$ -in. bolt with a $\frac{1}{16}$ -in. hex head into the threaded hole. Leave the head of the bolt slightly above the table, so the slot in the clamp can be slid over it. The size of the slot just fits the head on the bolt and thus becomes a sort of wrench for tightening the bolt.

—Steve Acker, Arlington, Texas

Pop-on lid for turned container

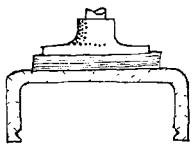

Turn container with groove near top.

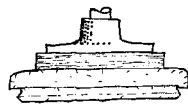

Turn lid with V-ridge.

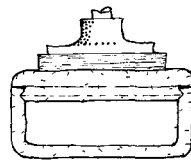

Sand ridge until lid pops onto groove of container.

When I was asked to make a turned container with a removable lid that would not come off, I accidentally devised the following system. Mount the workpiece blank with the grain running par-

allel to the axis of the lathe. This grain orientation will reduce moisture-change distortions. Turn the outside and inside of the container. Before removing the container, put the tool rest into the opening, and cut a slight recess just inside the opening.

Next, mount the container top on the lathe, and turn it with a V-shaped ridge around its bottom. Size the ridge to just start into the bottom's opening. Gently round off the point with sandpaper until the lid will pop into the container. To complete the container, put the two pieces together, and blend their profiles on the lathe. To make a tight joint, I undercut the outer edges. I wax the joining surfaces to ease the lid attachment and cut down on long-term wear.

—J. Harvey Baker, Waynesboro, Tenn.

Salvaging warped scraps

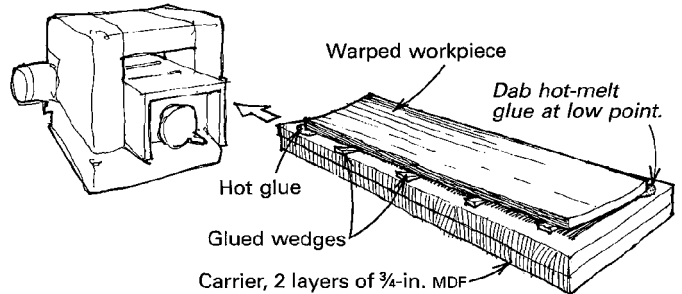

Almost all woodworkers hate to throw away short lengths of twisted or warped wood. But sending these boards through a thickness planer usually doesn't eliminate the problem—the wood only gets thinner. However, by temporarily securing the deformed board to a carrier surface with wedges and hot glue

and then sending both carrier and board through the planer, you can rescue the board.

For the carrier, I prefer two 3/4-in. layers of glued-up medium density fiberboard (MDF). I mount a warped board to the carrier using 50-cent sized dabs of hot-melt glue at the low corners. Then, every 6 in. or so, I wedge shims under the board and secure them with hot-melt glue. The wedges support the edges of the board and prevent it from rocking while in the planer. After the glue has set, I send the assembly through the planer to flatten the top side. Then I separate the board from the carrier, scrape off the glue residue and plane the other side.

—James R. Myers, Dallas, Texas

Portable stand for lathe tools

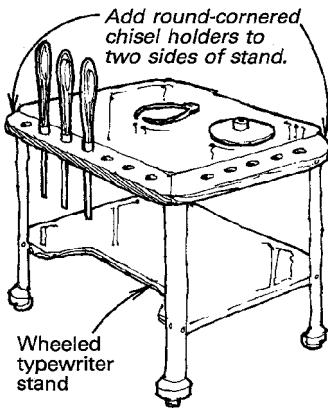

This portable lathe-tool stand is made from an old, wheeled typewriter stand. These stands are easy to come by now that computerized word processors have pushed typewriters out of many offices. Just attach drilled boards on two sides to provide a place to hold your turning chisels. Round the corners of these tool racks to avoid gouging your hips. The stand can be rolled within reach, and its table is ideal for storing faceplates, chucks, gauges and glue. The stand is

especially useful for turners like me who work on several lathes in a day. And at the end of the day, the whole thing moves quickly out of the way to speed cleanup. I still have lathe-tool racks attached to the wall, but I've moved them across the shop where they aren't always festooned with shavings and sawdust.

—Stephen H. Blenk, Sequim, Wash.

En garde push stick

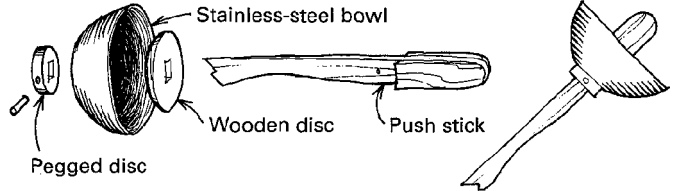

I designed a special tablesaw push stick after we experienced a 43-stitch kickback in our shop where we manufacture magic props. The guard protects the fingers and hands, which are most exposed to potential damage during a kickback.

To make the push stick, I started with a stainless-steel custard bowl about 5 in. or so across, and then I added two turned wooden discs, one inside and one outside the bowl. A mortise through the discs accepts a removable push stick, which locks into place with a dowel pin. Yeah, it looks like overkill—but remember, we only have ten fingers.

—Carl Williams, Pasadena, Calif.

Quick tip: While browsing in a bike shop, it struck me that the quick release cams used on the front hubs, handlebars and seats of bicycles would make effective clamps for locking the moving

parts of jigs. So I used one of the cams to secure the two parallel sliding surfaces of a tenoning jig. —Henry Hewitt, Plano, Texas

Stop for a radial-arm saw fence

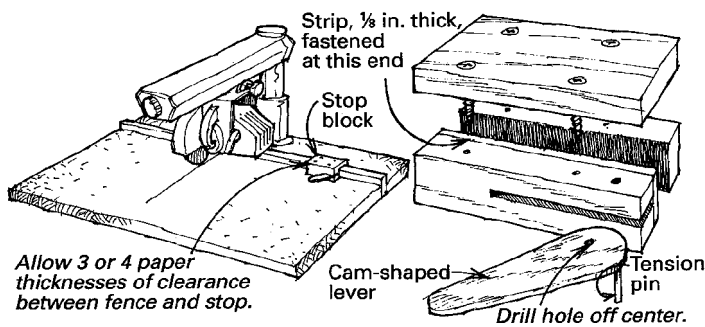

A fence stop for a radial-arm saw should be quick to set, reset and remove. It should be inexpensive to make, immovable when locked and unaffected by packed sawdust. The fence stop illustrated above, which operates on a cam-clamp principle, meets all of these criteria.

To make the stop, I recommend using solid oak or maple. Start by roughing out the top, front and back. Set the dimensions of the fixture so that the front and back ride above the saw table a bit to allow for sawdust. Cut a slot for the cam lever in the front, and then make the 1/4-in.-thick cam lever with a 1 1/8-in. semicircle on one end tapering to a 3/8-in. semicircle on the other. Drill the cam's pivot hole off center (3/2 in. or so), and install it with a tension pin. Then attach a 1/8-in.-thick face strip (glue and screw a pair of tiny, flat-head screws at one end). The

strip should be free along half its length. Secure the front piece to the top using glue and a pair of screws, and place this assembly on the fence. Using three or four sheets of 20 lb. paper to allow clearance, glue and screw the back piece to the assembly. The fixture should slide over the fence smoothly, but grip the fence when the cam is turned. To complete the fixture, trim both ends to 90° using the radial-arm saw.

—John B. Moon, Mount Vernon, Wash.

Quick tip: For starting screws in tight corners and other hard-to-reach locations, attach the screw to the screwdriver blade with a dab of rubber cement.—Howard E. Moody, Upper Jay, N.Y.

Scraping cock beads with a sabersaw blade

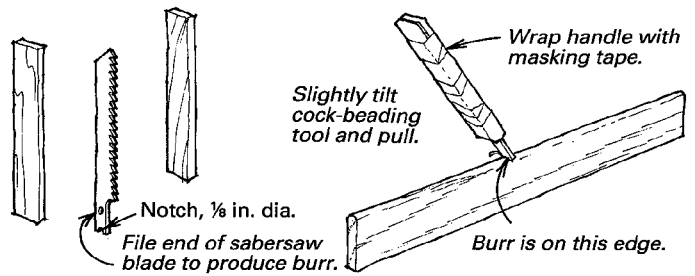

After I had resigned myself to handmaking a scratch stock blade to scrape a rounded profile onto 1/8-in.-thick cock-bead stock, I suddenly realized I already had the perfect scratch-stock blade in my toolbox—a sabersaw blade.

I sandwiched the blade between two thin pieces of wood and wrapped the makeshift handle with masking tape. After sharp-

ening a semicircular notch in the blade with a tapered sharpening slip (or needle file), I ran the tool's notch over the edge of the stock several times, tilting the tool slightly in the direction of movement to let the sharpened edge do the cutting. The result was a perfectly rounded cock-bead molding.

—Richard Glaczier, Gulfport, Miss.

Improved dovetail jig

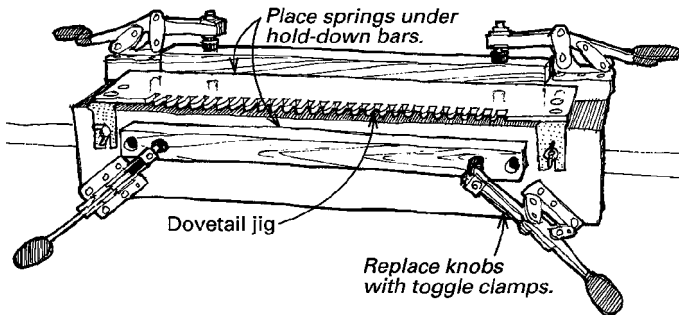

To speed up routing of dovetail joints, replace the screw knobs on your jig with fast-acting toggle clamps. Place springs under the hold-down bars, so they raise when the clamps are released.

—Jon Matthiae, St. Paul, Minn.

Quick tip: So that I could apply more force to my adjustable clamp handles, I slipped tight-fitting rubber automotive hose over the painted handles. To install the hose, I first lubricated the handles with hydraulic brake fluid, and then I tapped them on.

—David W. Carnell, Wilmington, N.C.

Making a staved cylinder

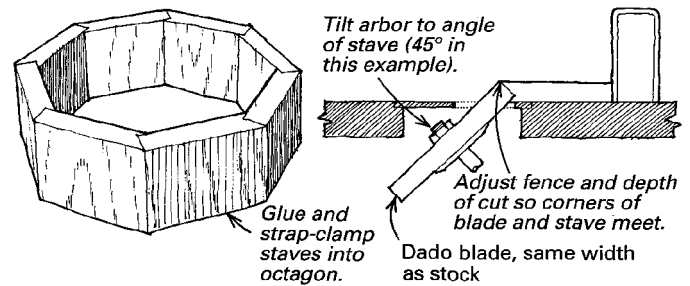

I picked up this clever technique to produce a staved cylinder from an antique pedestal table I restored in my shop. To make the joint, first cut the staves to their finished length and width. Then install a dado blade the same thickness as the stock in the tablesaw, tilt the arbor to 45°, for example, to produce an octagon, and plow a groove along one edge of each stave. Adjust the depth and fence distance so that the corner of the dado blade meets the corner of the stave, as shown in the drawing above.

When the grooves are completed, glue up the cylinder using strap clamps to apply pressure. Because the joint is self-locking and aligning, assembly is virtually foolproof.

—Colin W. Robertson, Rosemont, N.J.

Methods of Work buys readers' tips, jigs and tricks. Send details, sketches (we'll redraw them) and photos to Methods, Fine Woodworking, PO Box 5506, Newtown, Conn. 06470-5506. We'll return only those contributions that include an SASE

Hanging rip fence

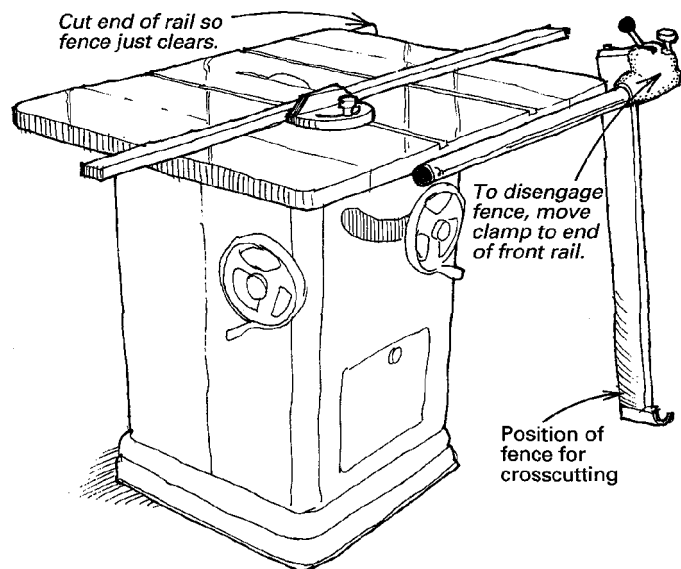

Removing and then reinstalling the rip fence from my saw each time I crosscut a long board was time-consuming and awkward. My solution was to cut the rear rip-fence guide as shown to allow the fence to hang from the front guide. After the cut, I simply swing the fence up and reinstall it on the rear guide.

—R. Coady, Picton, Ont., Canada

Guide for drawing parallel lines

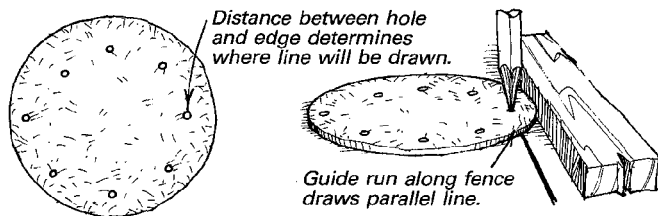

Here is a tool used by old-time patternmakers and draftsmen to lay out parallel lines. Strangely enough, I don't think this tool was ever commercially available; the old craftsmen just made their own. The tool is simply a flat, 1-in.- to 2-in.-dia. steel, aluminum or brass disc with $\frac{1}{16}$ -in.-dia. holes drilled around the edge. The space between each hole and the edge of the disc determines the distance between the drawn line and the fence guiding the disc. I bored my holes in from the edge at points that mark the decimal equivalents of fractions commonly used in woodworking. The $\frac{1}{16}$ -in.-dia. holes are just large enough to accommodate a scribe point or sharp pencil point.

—Devore O. Burch, Fort Worth, Texas

Drawer stop

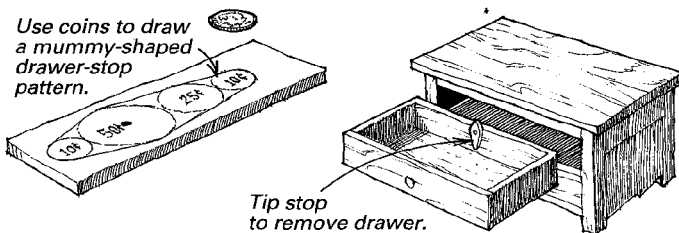

Years ago, I built some 9-in.-deep drawers into a bookshelf. Because they were so shallow, the drawers were always at risk of

being pulled out of the case. I thought about it for a while and came up with the drawer stops shown in the illustration.

First, make a mummy-shaped pattern by connecting the outlines of a dime, a half-dollar, a quarter and then a dime again on a piece of thin stock. Make the pivot hole in the center of the half-dollar. Trace, cut out and sand as many $\frac{1}{4}$ -in.-thick wooden drawer stops as you need. Install these in the drawer back with a round-head screw over a small brass washer. Mount the stop low enough on the back so that when it is tilted, its edge does not go above the top. The stop should swing freely. In a wide drawer, two stops might be better than one.

—John B. Moon, Mount Vernon, Wash.

Knockdown workbench

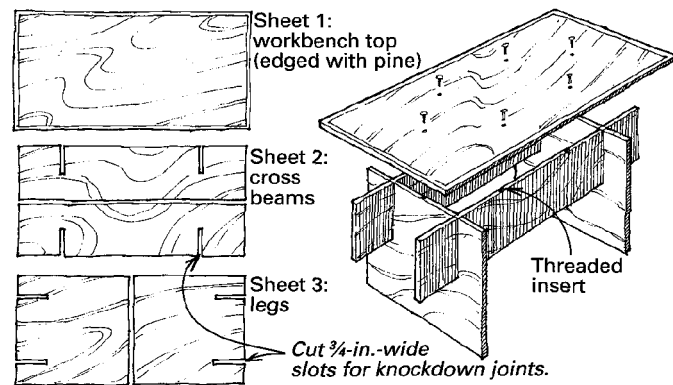

A professional cabinetmaker friend of mine discovered this workbench system that is light, compact to store, quick to break down and can really take heavy abuse. To make the workbench, pick up three sheets of $\frac{3}{4}$ -in. plywood on sale. Rip one sheet in two vertically to make the cross beams and slice another sheet in two horizontally to make the legs. Edge the third sheet with pine to make the workbench top. Cut mating $\frac{3}{4}$ -in. slots in the legs and cross beams, so they can be assembled into the workbench's undercarriage. Fasten the top to the undercarriage with screws into threaded inserts.

—Nicholas S. Tyler, Manotick, Ont., Canada

Quick tip: Add strips of plastic laminate to the bottoms and sides of drawer guides. The drawers will slide easier and wear forever.

—Boles M. Derenda, West Seneca, N.Y.

Wooden bed-bolt covers

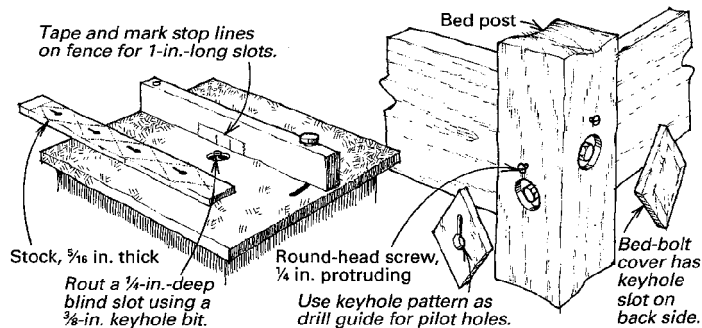

Not long ago, I made a pencil post bed and covered its eight bolt heads with traditional brass bed-bolt covers. When the next project, a pair of bunk beds, required twenty-two bolt covers, I abandoned the brass tradition in favor of hardwood covers. After making wooden covers, I'm now convinced that they're better than their brass predecessors in several ways—they're easily made in any size, shape and color, their attachment

screws are concealed and they're certainly less expensive.

To make diamond-shaped covers, mill a piece of wood $\frac{3}{16}$ in. thick and long enough to cut all the covers. Lay out a centerline on the underside, find the centers of the diamonds and draw their shape. Using a $\frac{3}{8}$ -in. Forstner bit in a drill press, drill a $\frac{1}{4}$ -in.-deep hole into the center back side of each diamond. This leaves about $\frac{1}{16}$ in. undrilled. Next, using a $\frac{3}{8}$ -in. keyhole bit in a router table, carefully set the fence so the bit fits the holes just made (see the sketch on p. 14). As before, set the bit's height $\frac{1}{16}$ in. shy of the wood's surface. Stick some tape to the fence, and make a mark to denote the center of the keyhole bit. Make a second mark as a stopping point for a 1-in. blind cut.

After you've made the guide marks, lower the workpiece onto the bit and make the first keyhole cut. With the router still running, carefully draw the board back to the bit's insertion point, and lift it off the bit. Then make repeated keyhole routings right down the board. Now you're ready to cut out the diamonds, plane off their corners and smooth them. Using a jig like the one shown in the sketch, drill pilot holes into each bed post and install round-head screws (about $\frac{1}{4}$ in. proud) to hold the wooden covers. Because the bed bolts (for headboard and footboard) on the sides of most beds are higher than the rail bolts on the ends, the neighboring bolt covers will be at different heights. If this presents a problem, make the covers long enough to conceal either bolt hole, and install them at the same level.

—John B. Moon, Mount Vernon, Wash.

Quick tip: Use Post-It note pads to identify the parts of a wood-working project (lower left stile, bottom drawer front, for example). If you clean the wood before applying the note, it will stick without leaving a residue. —Anthony P. Matlosz, Howell, N.J.

Routing a raised-rim tabletop

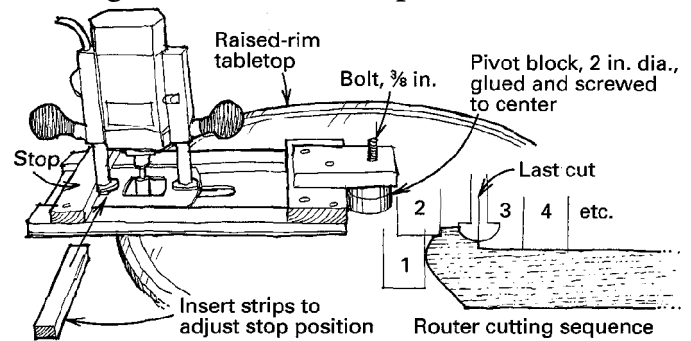

In reproducing an 18th-century pedestal table, I was faced with the problem of forming a raised-rim top. The traditional method was to use a lathe for this process. But even my small 25-in. top was far beyond the capacity of my lathe. So I devised this router jig to shape the table's top.

First, I cut the top to the required diameter on a bandsaw and then screwed a pivot block holding a countersunk $\frac{3}{8}$ -in. bolt to the center of the top. The sinking was to be $\frac{3}{16}$ in. deep, so I made sure the pivot block's screws only penetrated $\frac{1}{4}$ in. Then I made the fixture to pivot on the bolt. With a two-flute straight bit in the router, I initially used the setup to true the edge of the top to a perfect circle; I made subsequent cuts from the outside in. To avoid having to move the stop for each cut, I inserted spacing strips to position the router for up to four sweeps of the jig before I had to reposition the stop. When as much as possible of the sinking had been done in this way, I used a core box bit to form the cove on the rim. To sink the central part of the

table, I removed the pivot block and lengthened the base of the jig to span the width of the top. Finally, I smoothed the entire recessed top with a plane and a scraper.

—Dr. Ralph Sinnott, Wolverhampton, England

Making tapered cylinders without a lathe

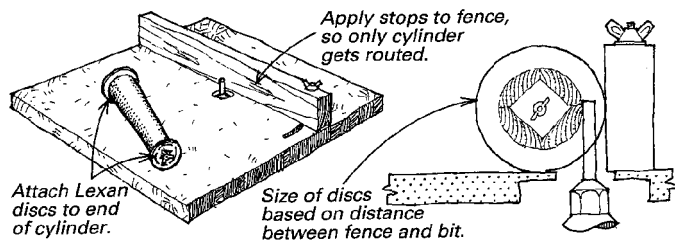

I use a router table to make tapered cylinders for kaleidoscopes, but the method could be adapted to make table legs or large dowels. I start by gluing up four pieces of wood into a column. Then I attach two ¼-in. Lexan plastic circles to the ends of the column using a threaded rod and wing nuts. If the workpiece is solid, you can attach the circles with screws. I press the assembly against the router-table fence and make repeated passes, turning and sliding, to produce the cylinder. Stops on the router-table fence keep me from routing into the circles.

Note that two equally sized circles produce a straight cylinder, and unequally sized circles produce a taper. The circles should be larger than the cylinder by the distance of the router bit from the fence. In my case, I use 5-in. and 4½-in. circles to cut cylinders that taper from about 3 in. to 2½ in.

—John Grant, Palmer, Alaska

Turnbuckle clamp

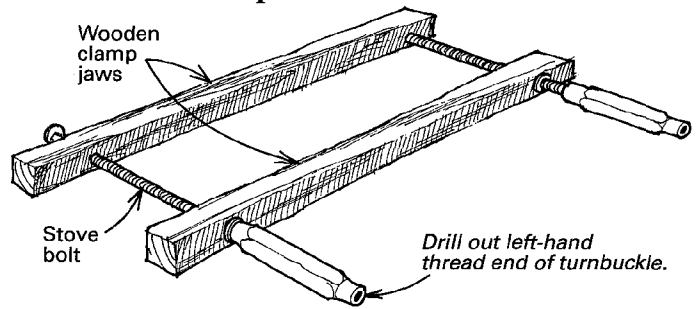

I make an inexpensive box clamp from turnbuckles, long stove bolts, washers and scrapwood. Remove the ring bolts from the turnbuckles and drill out the threads on one end.

—Dan Wilson, Chesterfield, Mo.

Miter-gauge alignment fixture

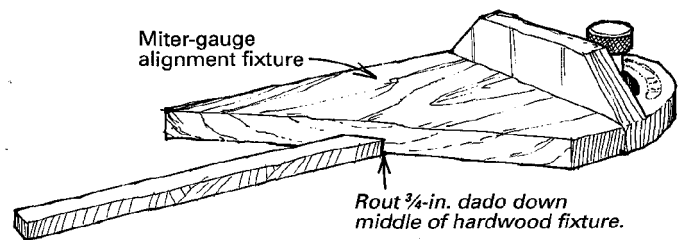

Years ago, I read that you could easily adjust a miter gauge to 90° by turning the gauge upside down, pushing it into the ta-

blesaw slot and tightening the bar. Perhaps this method works on some saws but not on mine.

As an alternative, I built a hardwood alignment fixture slightly wider than my miter gauge. I routed a $\frac{3}{4}$ -in. slot down the middle underside of the fixture to fit the miter-gauge bar. With the help of a square and a plastic triangle, I cut one end of the fixture to a perfect 90° and the other end to a perfect 45° . I've since added a second fixture for 30° and 60° . To adjust the miter gauge, I place the fixture, slot down, on the miter-gauge bar and tighten the face to the setting. It's fast and accurate.

—Clyde Hunter Jr., San Jose, Calif.

One-minute taper jig

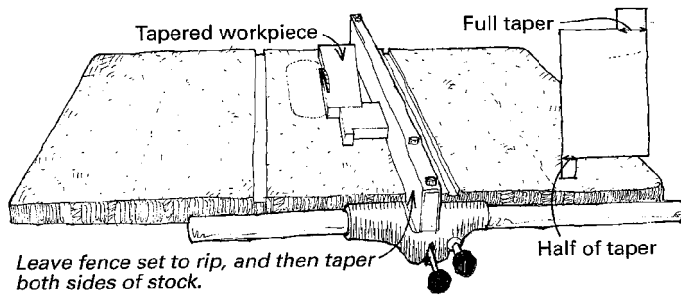

I use a jig to taper a guitar's fingerboards, but the jig could be adapted to table legs or any short tapering job. The limiting factor is the length of the rip fence.

Start with a piece of hardwood scrap that's narrower than the work. Cut a notch into both ends of the jig to leave two fingers. One finger should be half as wide as the taper, and the oth-

er finger should be as wide as the taper. To use the jig, first rip the workpiece. Then, without changing the fence setting, insert the half-taper notch between the fence and the workpiece, and trim one side. Flip the workpiece over and flip the jig end for end to trim the second side. The resulting workpiece will have square ends and equal tapers. —Phil Clark, Homestead, Pa.

Quick tip: A magnet from a junked radio speaker makes an excellent stop block on the tablesaw. Just plop the strong magnet where needed. The magnets require no clamps and are infinitely adjustable. —R.A. Bolster, Ashland, Ore.

Storyboard for routing dadoes revisited

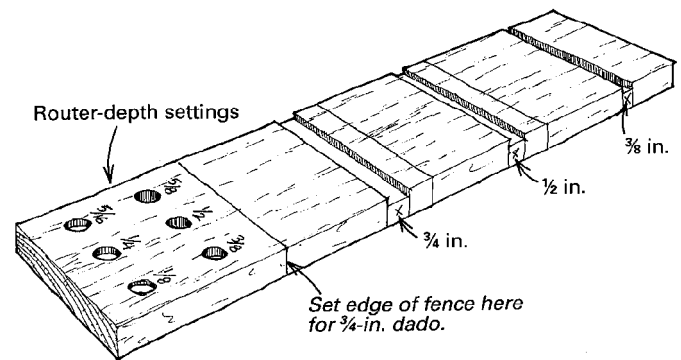

I added a couple of improvements to Keith Schubert's dado routing jig (*FWW* #91, p. 16). Rather than measuring and transferring the edge-to-bit distance from the router to the jig, I just clamped a fence to each of the lines and routed a dado with the

appropriate bit. This quick and accurate approach also makes it easy to see the location of the dado when using the jig.

An improvement for gauging bit depth (instead of making marks along the board's edge) is to bore holes of the appropriate depth in the end of the jig. Use your largest diameter bit and a plunge router to drill the holes. The holes will ensure exactly the same depths every time, literally in seconds, without any measuring.
—Gerard R. Mack, Badalasco, Italy

Quick tip: For shop vacuum system fittings, use regular 2-in PVC couplings. Just cover the inside of the joining area with felt (using PVC cement) for a perfect fit.

—Walter Sheard, Horsehead, N.Y.

Multi-use bandsaw auxiliary table

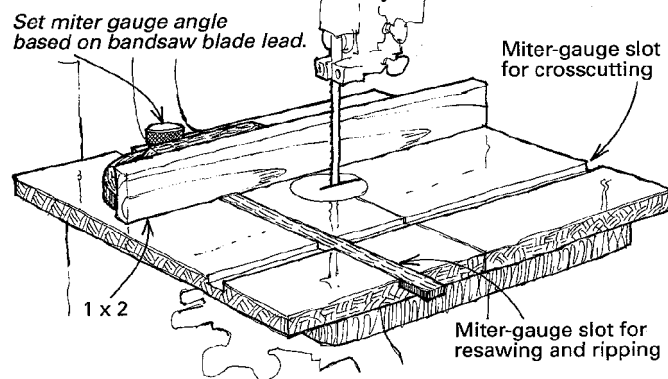

Ripping and resawing on the bandsaw is always a problem because of the tendency of each blade to naturally lead the cut in

a slightly different direction. The traditional method of compensation is to find the lead angle, mark a line on the table, and then clamp a makeshift fence parallel to this line. The auxiliary table shown in the sketch improves on that solution by borrowing your table saw's miter gauge for ripping as well as crosscutting on your bandsaw.

I made my auxiliary table from a discarded laminated kitchen countertop, but a good grade of plywood would work just as well. Size it a little larger than the original table, then drill through both tables and fasten them together with four countersunk carriage bolts. Cut a slot for blade entry and a hole with a recessed edge for the throat plate. Now cut two $\frac{3}{4}$ -in. dados to fit the miter gauge. Cut one parallel to the blade for standard crosscutting operations and then a second dado at a 90° angle to the first for ripping and resawing.

To find a blade's lead angle, mark a centerline on a piece of 1x2 scrap stock. Carefully rip freehand along this line until the stock reaches the rear of the table. Leave the 1x2 in this position and insert the miter gauge in the second slot as shown. Loosen the protractor adjustment knob, and slide the miter gauge up to the workpiece. Adjust the fence angle to the lead angle you just found, then tighten the protractor knob. Remove the 1x2, position the miter gauge for the desired cut width, measuring from the front of the blade, and clamp the gauge in place. You're now set up for accurate, repeatable ripping or resawing.

—Anthony P. Matiosz, Howell, N.J.

Methods of Work buys readers' tips, jigs and tricks. Send details, sketches (we'll redraw them) and photos to Methods, Fine Woodworking PO Box 5506, Newtown, Conn. 06470-5506. We'll return only those contributions that include an SASE.

Router circle-cutting jig

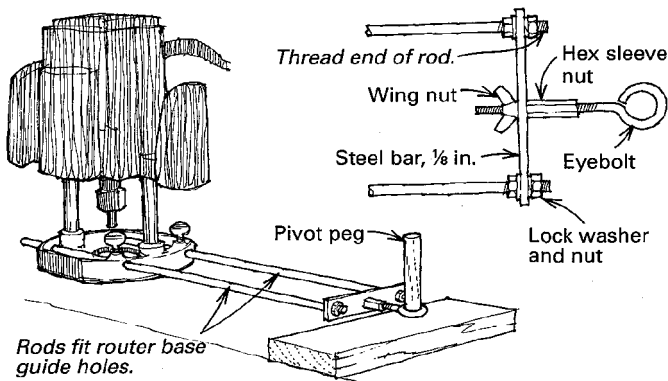

This inexpensive but accurate circle-cutting jig is made with two 18-in.-long rods that fit the guide holes in your router. Cut threads on one end of each rod and, using nuts, attach the rods to a length of 1/8-in.-thick steel bar, as shown above. Take care to ensure that the rods are parallel and spaced the right distance apart. For the pivot, attach an eyebolt to the center of the steel bar with a hex sleeve nut and a wing nut. For the center (pivot) peg, I use a 3/4-in. dowel, shaved down slightly to fit the center of the eyebolt.

—James Guerami, Lake Forest, Calif.

Grinder-in-a-box

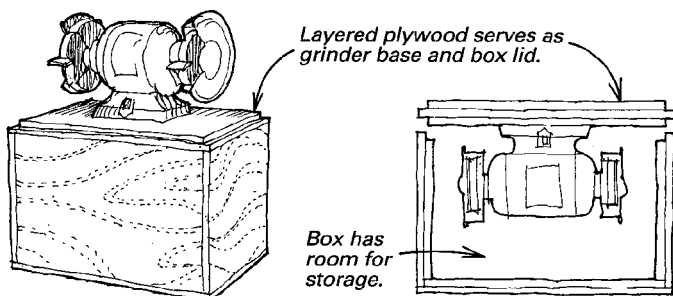

I designed this box to protect my grinder when I have to take it to the job site. There's room in the box to place grinding wheels, wrenches and other accessories, too. By flipping the grinder over and fitting the base into a ledge in the box, the box becomes a no-compromise stand, which I can also use in my shop.

—Mike McCallum, Gresham, Ore.

Cutting concave bevels on the tablesaw

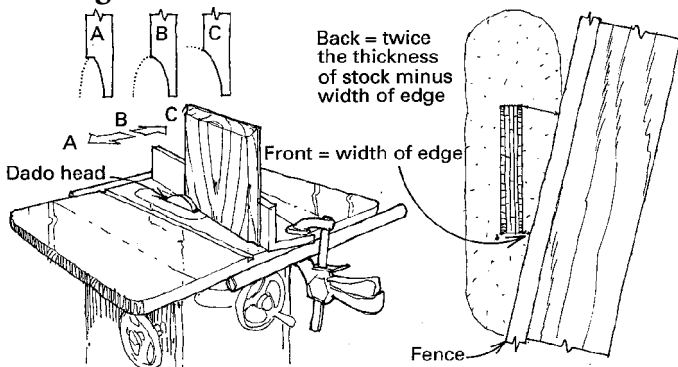

In "Machining Raised Panels" (FWW#94), Joe Beals says concave bevels fit better into the frame than straight bevels. I also have had good results making concave bevels using a modified cove cut on the tablesaw. I run the panel on edge past a dado head using a fence clamped at a slight angle to the blades.

There are several profiles possible using this approach. I pre-

fer the look of profile B in the drawing, which is produced by setting the blade height to the desired field width and angling the fence according to the instructions shown in the drawing. Moving the fence closer to the rear of the blades will produce profile A, and moving the fence farther from the rear while raising the blades will produce profile C. This cut doesn't usually require a zero-clearance insert. However, a tall fence and a couple of featherboards can greatly enhance the operation.

I usually use a scraper ground to the appropriate curve to clean up the bevel.

—David A. Hood, Corvallis, Ore.

Knockdown saw stand

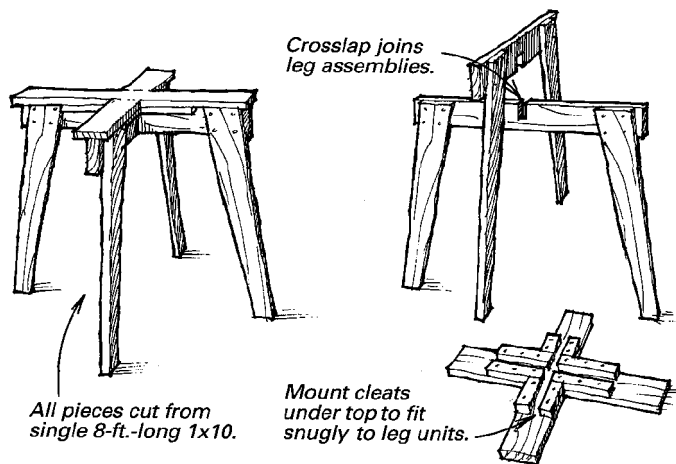

Because I don't have enough space in my tiny shop for a table saw, I designed this lightweight, knockdown table saw stand that stores away in three flat pieces. When I need my table saw, I simply set up the stand outside the door of my shop and mount the saw. There are no screws, pins or pegs, so the stand can be put together in seconds.

To make the stand in about an hour, all you'll need is an 8-ft.-long 1x10 and a handful of 1 1/4-in. plaster wallboard screws. Then follow the construction details shown in the sketch. The stand requires a snug fit of the leg assemblies into the cleats, so pay special attention when you attach the cleats to the underside of the top.

—Ray Mayotte, Worcester, Mass.

Flattening a workbench top

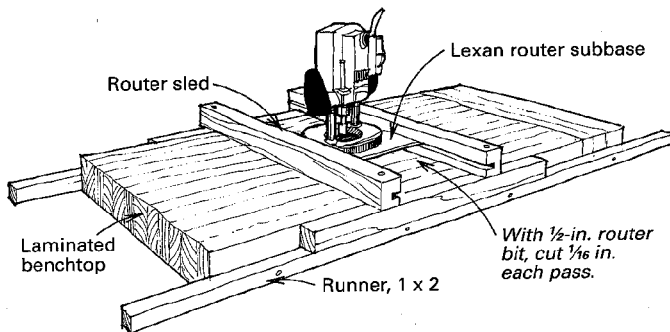

I recently completed my first workbench, a large traditional design with a heavy laminated maple top. After assembly, I flattened the top of the bench by adapting Tage Frid's method from Scott Landis' *The Workbench Book*. First, I installed a 1/4-in.-thick Lexan plastic subbase on my router. Then I screwed 1x2 fir strips down each side of the bench, extending the strips far enough past the ends so I could rout the entire length. To make sure these two runners were parallel, I used two winding boards. Then, using scrap maple, I made a sled that bridged the table-top and incorporated grooves for the Lexan router base. To sur-

face the table, I simply started at one end and, with a 1/2-in. bit in the router, cut 1/16 in. in a pass. It is a little slow, but it works.

—Herb Hunter, Denver, N.C.

Repairing large defects in tabletops

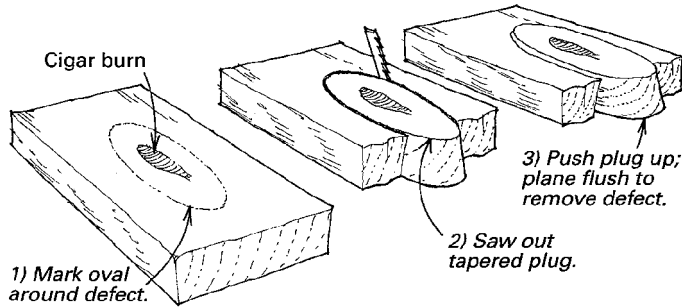

Recently, one of my restoration-shop customers brought in an antique table that had a deep cigar burn in its top. The owner wanted the burn removed but did not want the top patched with what she called "foreign wood." Sanding or scraping the flaw would leave a deep dish, so those options were out of the question. Instead, I came up with a way of repairing the defect using the existing wood.

First I penciled an ellipse around the burn. On one side of the ellipse, I drilled a series of angled 1/16-in. holes next to each other and connected them with a small chisel to allow entry of a narrow jigsaw blade with its rear corners rounded. With the jigsaw set to the same angle as the starter slot, I sawed around the ellipse, which created an oval plug. This plug could then be pushed up from the bottom about 1/8-in. because of the space

created by the sawkerf. (By varying the saw's angle, you could vary how much the plug will come up to suit the depth of a defect.) After I leveled the top of the plug, some minor dry-assembly and filing yielded a nearly invisible joint with a perfect grain match. The nice thing was that the underside of the patch was hidden by one of the table's structural members.

—Charlie Giustiniani, Cold Spring Harbor, N.Y.

Stropping block for sharpening lathe tools

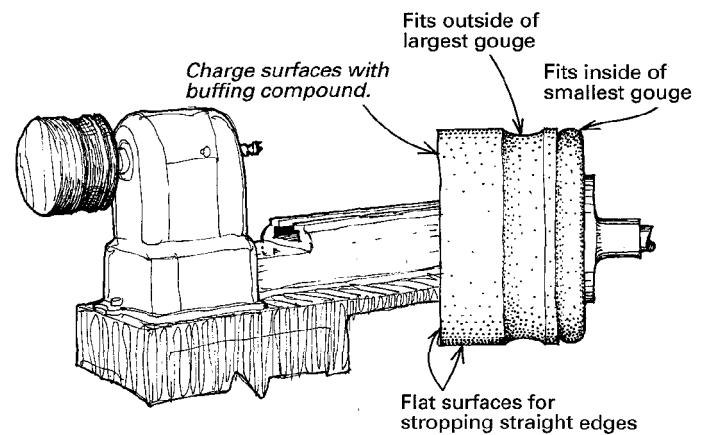

You can take some of the drudgery out of the grinding-honing-stropping cycle of sharpening all your tool edges by making this gadget for your lathe or drill press. It is simply a turned cylinder with cove and bead sections for stropping gouges and two straight sections for stropping chisels, skewers and knives. Turn

the stropping block from a softer, even grained wood like poplar with a radius of 7 in. and a length of 4 in. The radius of the cove should be slightly larger than your largest gouge, and the radius of the bead should be slightly less than your smallest gouge. Periodically, charge the surface of the cylinder with a stick of white buffing compound. This is a fine abrasive that will leave all your tool edges sharp enough to shave with.

Strop a gouge by laying its outside bevel in the cove of the rotating stropping block. Roll it side to side to get the entire cutting edge. Turn the gouge over and strop the inside edge on the beaded section of the block. Straight edges can be stropped on the face of the block or on the flat end section. If you mount the stropping block to the outboard end of your lathe, you can touch up turning tool edges without interruption while turning.

—Anthony P. Matlosz, Howell, N.J.

Quick tip: Glue magnetic tape, like that used on magnetic car signs, to the bottom of your oil-stone box. Then, when sharpening, just place the box on top of your tablesaw (or other steel surface) and it will stay put. —Lewis A. Larsen, Eagle Grove, Ia.

Ultimate glue applicator

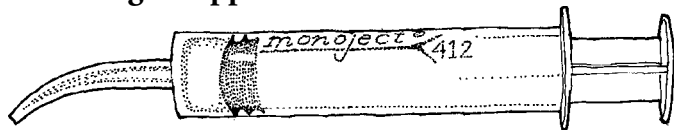

Applying glue to joints has always been a messy chore, especially when it involves tricky corners or overhead surfaces. This curved-tip plastic syringe (Monoject #412, available for about 40 cents from any hospital supply company) solves the problem

perfectly. The tapered, curved tip may be trimmed to handle the viscosity of any adhesive and allows easy access to all joints. Simply push a pin or nail into the tip to preserve the adhesive for later use.

—Gary Ouwerkerk, Los Osos, Calif.

Tool-running light for deaf woodworkers

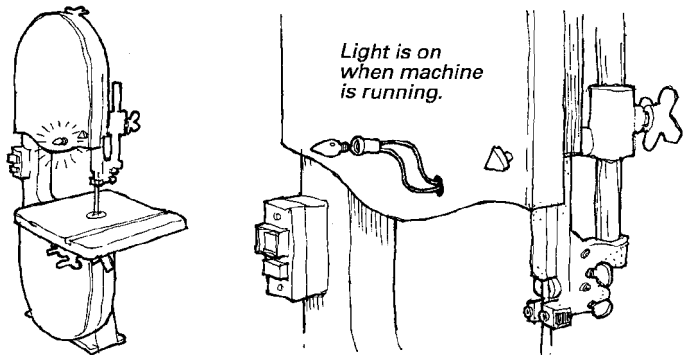

As a deaf woodworker, I became concerned about safety after returning to my bandsaw several times and finding it running. This is scary because, as you know, a bandsaw is also a meat-saw. So I decided to place a colored tool-running light on each of my tools. After experimenting with several types of lights, I finally settled on old-fashioned screw-in Christmas lights. I pick a highly visible spot on the machine, mount the plastic lamp socket in a snug hole and splice the wires right into the motor side of the on/off switch. The bright, colored bulbs hold up well, and I already have a box full of replacements.

You might think that a person could become accustomed to

the lamp and ignore the warning. To the contrary. I find that I look for it specifically when approaching the machine.

—H. E. McLaughlin, Sacramento, Calif.

Quick tip: After I realized how much time I was wasting winding and unwinding cords, I cut each power tool's cord to an 8-in. length. I was using them with an extension cord anyway. Now when I'm through, I just lay the tools on the open shelf.

—Michael McCloskey, Tehachapi, Calif.

Lumber storage system

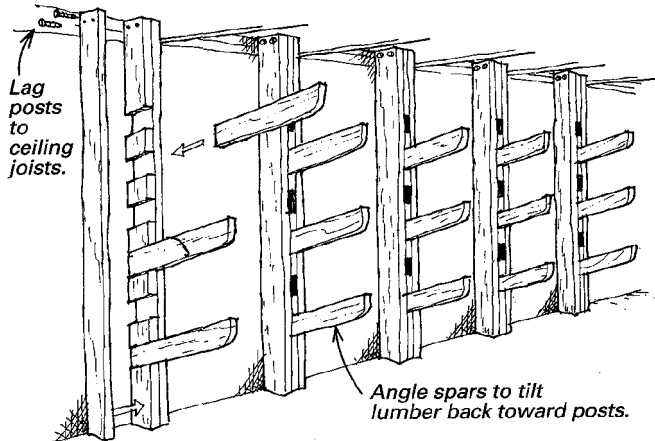

My boss, Jim Gibson, was once a shipwright in his native Scotland. So when I asked him to help me design a lumber storage system for my basement shop, he had more than a few good

ideas. This design for an adjustable storage rack, for example, has proved to be quite effective and inexpensive.

—Duane E. Holmes, Ont., Canada

Improved marking gauge point

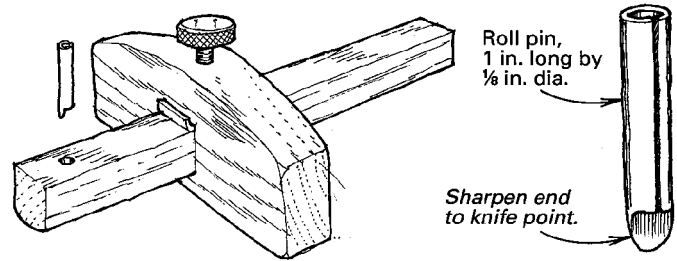

Here's a marking gauge point that has several advantages: It leaves a knife-clean line, and its depth and angle to the marking gauge fence are easily adjusted.

Start with a 1-in.-long, 1/8-in.-dia. roll pin, available at your local hardware or auto-parts store. The spring-steel pins, made to fit tightly in a hole, will really hold an edge. Grind or file away one end of the pin, leaving a knife-like nib as shown. Orient the nib opposite the slot in the roll pin. If grinding, dip the pin in water frequently to keep it from losing its temper, before you hone the nib on a whetstone. Install the pin in a properly sized hole through the marking gauge arm. Using a wooden block, press the pin in a short amount. Then, with pliers, angle the nib slightly so that it will pull the work into the fence when used. Press the pin in until only 1/8 in. of the blade is exposed.

When properly honed and installed, the new pin in your

gauge will mark a clean line across the grain of even open-pored wood, like red oak, without splintering or tearing.

—Rich Haendel, Iowa City, Ia.

Miter-joint biscuit jig

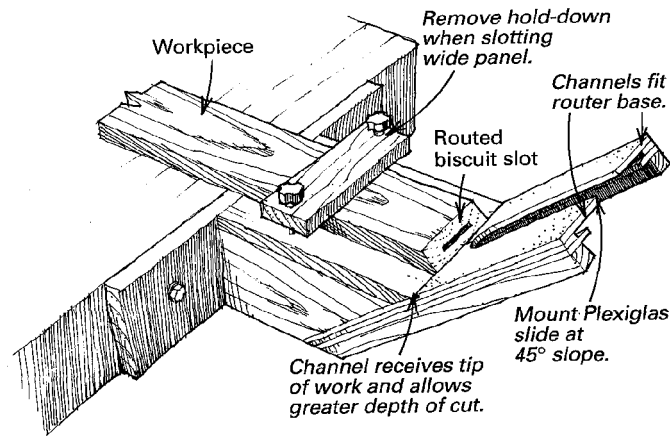

This jig, which I designed to cut mitered biscuit slots with a router, has eliminated my struggles with miter joints. It consists of a hardwood base, which bolts to my workbench, and an angled Plexiglas slide, sized to fit my router base.

To cut the slot, I use an Eagle-American biscuit cutter that has a ball-bearing limiter. The short shank on these bits limits the distance the cutter can be safely extended from the chuck. You can center the biscuit slot in $\frac{3}{4}$ -in. stock; in thicker stock, you'll have to accept a biscuit slot nearer to the outside of the joint.

Mounting the 45° Plexiglas slide is critical because the recess in the Plexiglas must fit the mitered corner of the workpiece perfectly. To aid in this assembly, place a mitered workpiece in the jig to register the Plexiglas in the right position as you mark the mounting holes. Make the mounting holes slightly oversized, so you can adjust the slide if necessary.

—Francis Chan, Nassau Bay, Texas

Multipurpose marking and scraping tool

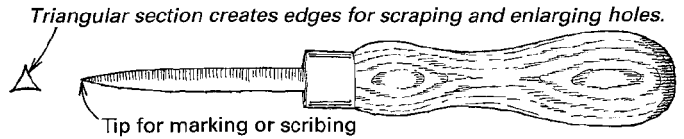

I find many uses for a bench tool made from the broken end of a small triangular file fitted with a handle. Grind the teeth off and point the end. File steel is tempered very hard, so other materials are unlikely to blunt it.

Use the tool as a marking awl. When twisted, it will enlarge a hole or mark the center of a drilled hole. When drawn along a straight edge, it will scribe a line. Used sideways, it will scrape solder off metal or glue off wood. As a lathe tool, it will true the end of a metal tube being made into a ferrule when turning a handle. —Percy W. Blandford, Stratford-upon-Avon, England

Methods of Work buys readers' tips, jigs and tricks. Send details, sketches (we'll redraw them) and photos to *Methods*, Fine Woodworking PO Box 5506, Newtown, Conn. 06470-5506. We'll return only those contributions that include an SASE.

Racking clamps

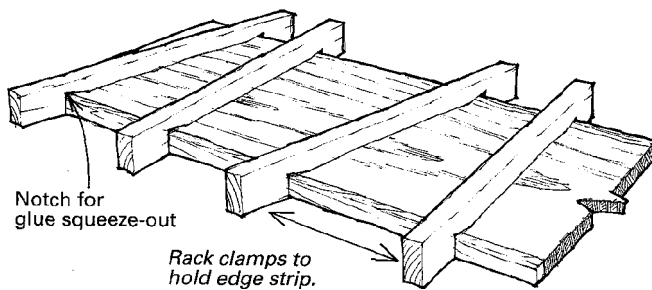

I often glue nosing or strips to the edge of dozens of same-sized boards. I may need 50 clamps. Metal clamps are too heavy, slow to set up and expensive. So I use what I call racking clamps, which I make up from wood I'd otherwise discard. The clamp is really a very broad, very shallow C-shape with the opening about 1/8-in. wider than the board plus the edging to be glued.

In making the clamps, I add a relief notch at the corners to avoid glue squeeze-out sticking to the clamps, and I take care to cut the faces at a perfect 90°. To use, I apply adhesive to the edging and then install a clamp every 6 in. or so by racking, which is bumping one end until the clamp wedges into place. The clamps apply plenty of pressure, and they set up easily. They also disengage instantly to realign the joint if necessary.

—Tom Schrunk, Minneapolis, Minn.

Quick tip: To aid in removing screws with stripped heads, dab a small amount of valve grinding compound (available at auto-parts stores) to the tip of your screwdriver. You'll be amazed how well this works on Phillips, slotted and Alien screw heads.

—Andrew Flowers, Alsip, Ill.

Mitering frames on the tablesaw

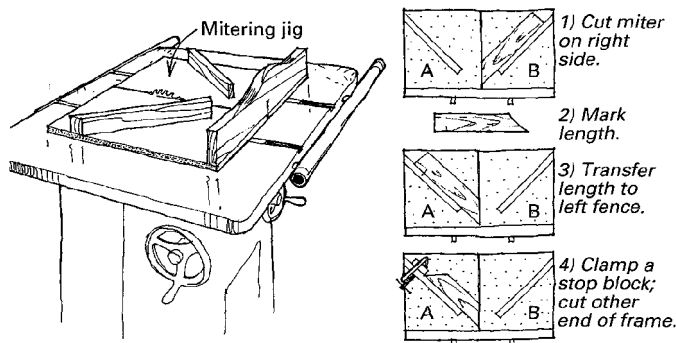

Much of the furniture I make is based on mitered frames, which require corners that have to meet perfectly. To make these frames, I use a sliding table jig on my tablesaw. The jig is simple to build, ideal to clamp work to and easily allows mitered workpiece corners to be marked for length.

Start with a piece of 1/2-in. plywood fitted with two rails on the bottom to fit in the tablesaw's miter-gauge slots and a fence at the back tall enough so it won't get sawed through. Place the fixture on the saw, and saw a kerf from front to back using the blade you will use for mitering. Now attach the left fence (fence A) to the base using a 45° triangle registered against the sawkerf to establish the angle. Attach the right fence (fence B) using a framing square set against fence A. Leave enough space between the tall fence and the angled fences for a typical frame workpiece. Also, for safety, make the throat between the fences wide.

To make a frame, first miter one end of all four pieces of the frame using fence B. Mark the required length on one of the workpieces, place the workpiece against fence A and transfer

the measurement from the workpiece to the fence. Clamp a stop block at this location on fence A. Now miter the other end of all the pieces. When assembling the frame pieces, be sure to join A's to B's. Any slight error in the fences is negated by the 90° included angle, which ensures that each frame corner is perfectly square.

—David A. Saunders, Manchester, Conn.

Foot-operated vise

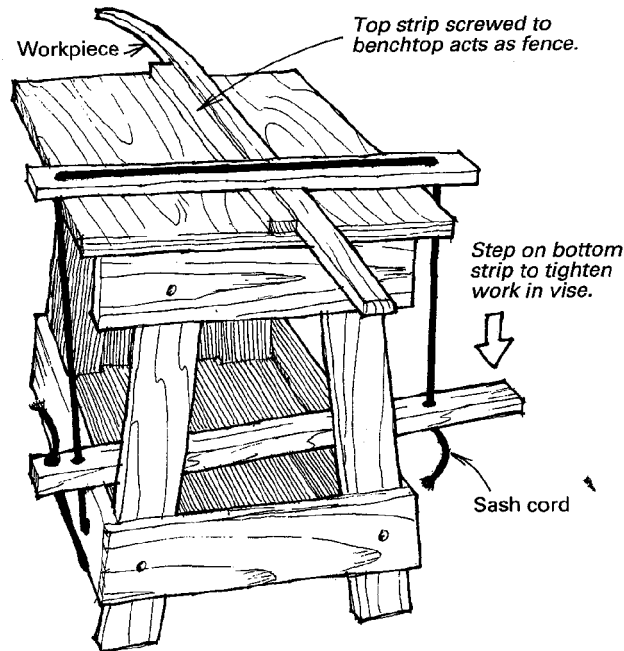

To help me cut a 15-ft.-long board into 2-ft. lengths on an outside worktable, I made this foot-operated vise with a piece of sash cord and two strips of wood. The top strip, which is screwed to the benchtop, keeps the stock from kicking around while I'm sawing; the bottom strip serves as a pedal to tighten the vise.

—Pendleton Tompkins, M.D., San Mateo, Calif.

Sand-filled lathe stand

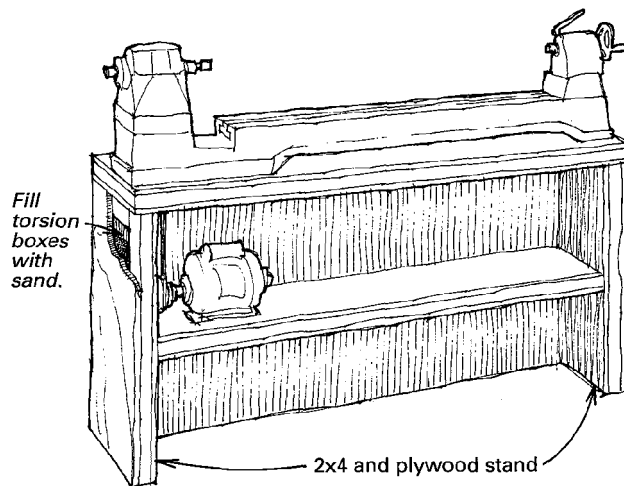

My 50-year-old wood lathe is a heavy cast-iron machine. When I mounted it on an old plywood lowboy cabinet that I had in my basement, there was noticeable vibration, especially when I started an out-of-round turning blank. So when I made a new stand for this machine, I decided to use sand-filled torsion boxes to add as much mass as possible. I constructed torsion boxes for the sides, back and top of the lathe stand and even for the

motor mount, using 2x4s and 3/4-in. fir plywood. When I laid out the boxes, I was careful to place structural members where I could attach the panels to each other, mount the lathe and mount the motor. After making the frames and attaching one plywood skin, I filled all of the cavities with sand. Then I fastened the other skin before assembling the stand. I have no idea how much this stand weighs, but almost all the vibration has been eliminated from my lathe.

—Jack McKay, Webster Groves, Mo.

Making matched decorative pieces

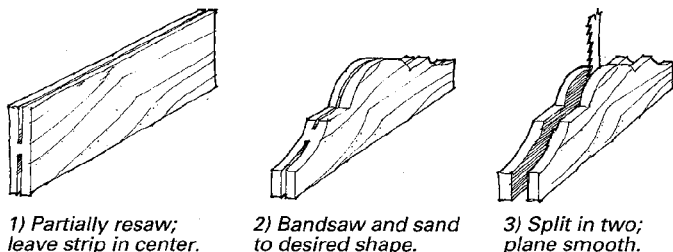

When I needed to make two identical book-matched curved profiles for the sides of a spice shelf, I came up with this simple solution. First, using a thin-kerf tablesaw blade, partially resaw the workpiece from both edges, leaving a 3/8-in. strip of unsawed wood down the middle. Then, bandsaw and sand the workpiece to the desired profile. When you are satisfied with the shape, separate the block in two by bandsawing the remaining strip. Finally, plane and sand the two identical sides to thickness.

—Susan Caust Farrell, Searsport, Maine

Square spindle center finder

Rotate turning blank until corners touch. Then press down to mark center.

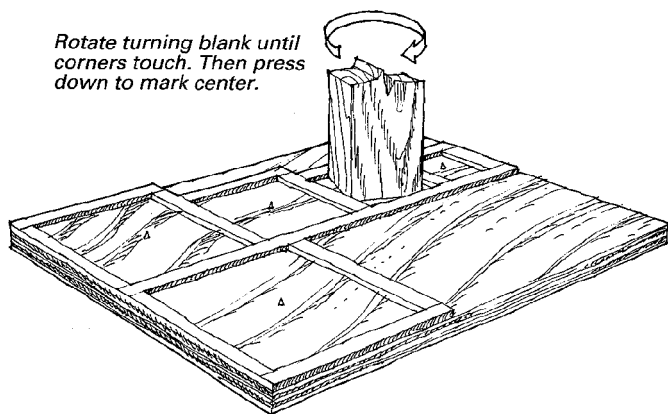

Here's a very old idea for finding centers on square stock. It's easily made, long lasting and as accurate as you want to make it.

Take a piece of plywood about 12 in. wide and 18 in. long. Make square recesses on the plywood by nailing down strips of 3/8-in.-thick stock as shown. Although the square recesses are labeled with common spindle dimensions, they are actually sized a bit larger according to the table below:

Stock size	Size of square recess
5 x 5	5 3/4
4 x 4	4 3/4
3 x 3	3 3/4
2 x 2	2 1/2
1 1/2 x 1 1/2	1 3/8
1 x 1	1 3/8

In the exact center of each square, drive a large nail. Cut off the nail, round and sharpen the stub to a point with a fine file.

Most other centering devices are awkward, but with this gadget, just put it on the bench, and prepare the stock without hassle. To mark the center of a spindle, place the stock in the square it's supposed to go in, lightly rotate the stock until all four corners of the spindle touch the sides of the recess and tap the other end. The indentation made by the nail will be exactly in the center and deep enough to give a firm lathe-centered locating point.

—Alan L. Hayes, Queensland, Australia

Quick tip: Use your computer to lay out multiple hole patterns. Using a + character for the center of the hole, set the hole locations by varying the characters per inch and lines per inch to get the spacing desired, then print. Spray the back of the paper with 3-M Spray-Mount adhesive and stick it to the workpiece for drilling. This works particularly well for plaques that have lots of little nameplates.

—Robert Vaughan, Roanoke, Va.

Chair seat drilling fixtures

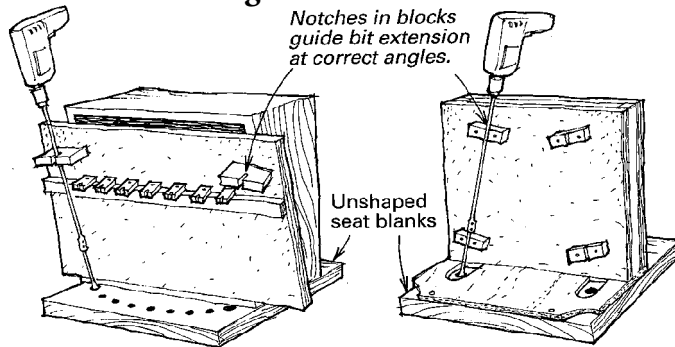

I use the two plywood fixtures shown above to drill precisely angled holes for the legs and spindles of the custom chairs I build. The fixtures' alignment blocks, whose locations and angles depend on the chair design, guide a long bit extension chucked in my portable hand drill. The length of the extension multiplies the accuracy of the hole angles, while the guide blocks help steady the regular spade bits I use. So that I'm working on a flat surface, I complete all the drilling operations prior to carving the seat.

—Ken Neitzel, Hancock, Vt.

Flawless seam for book-matching

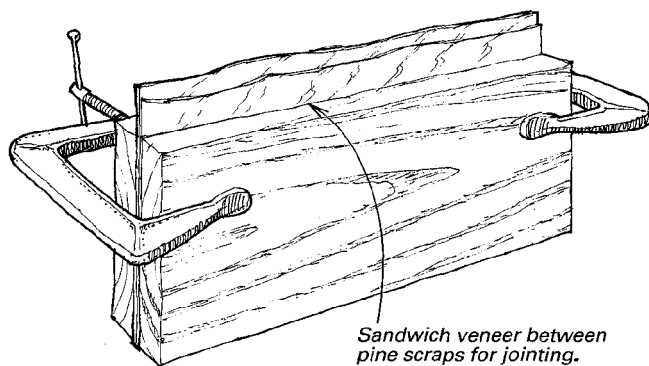

Here's a technique for producing a perfect seam on book-matched veneer. Start by playing with the two pieces until you get the desired grain pattern. Then, one at a time, cut each piece along the seam using a straightedge, a fresh razor-knife and many successive slices with light pressure. Leave a bit extra on both sides of the seam to allow for jointing.

Place the two pieces edge to edge, and then fold them together as though you were closing a book. C-clamp the two veneer pieces between two scraps of pine. Run this sandwich over the jointer slowly, taking a light cut to reduce splintering. Dismantle

the sandwich and check to be sure you have a perfect fit.

Using push pins, secure one half to your workbench. Push the other half firmly against it aligning the grain as you wish it to be. Secure this half with push pins, and apply paper veneer tape to the seam. When the tape is completely dry, remove the pins. Turn the workpiece over and, with a finger dipped into a glass of water, apply a little moisture to the wood fibers of the seam. Lay the piece on a hard surface, and gently tap the seam and the area near it with the round end of a ball-peen hammer. Properly done, this will spread the fibers of the wood and close any minor gaps in the seam. The book-matched piece is now ready to glue to the substrate.

—John B. Woods, Williams, Ore.

Needle file handles from mug pegs

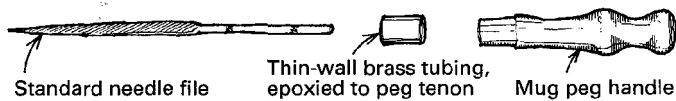

I've always had a problem with the commercial handles that are made for small needle files. They're too big and encourage too much pressure, often breaking the fragile files. And the cost for adding commercial handles to the dozen-plus needle files I routinely use was more than I could justify.

Looking for something smaller and less expensive, I purchased a bag of mug pegs at a woodworker's store. Then, stopping at a hobby shop, I selected a length of thin-wall brass tubing whose inside diameter ($\frac{1}{2}$ in.) would allow it to slip about one-third of the way onto the tenon of the mug peg—to act as a ferrule. At home, I lightly filed the wooden tenon of the mug peg until it fit snugly into a short section of the brass tubing. Af-

ter roughing up the interior of the brass tubing section with coarse steel wool, I tapped the tubing into place with a dab of epoxy to hold it firmly.

Later, after the glue cured, I filed the brass flush with the end of the mug peg. Then, to mount the file, I drilled a hole into the end of the peg using the tailstock dimple left over from the manufacturing process to center the hole. Finally, to protect the handles, I stained and polyurethaned the birch pegs.

—Charles Taylor, Sauk Centre, Minn.

Contour sanding fixture

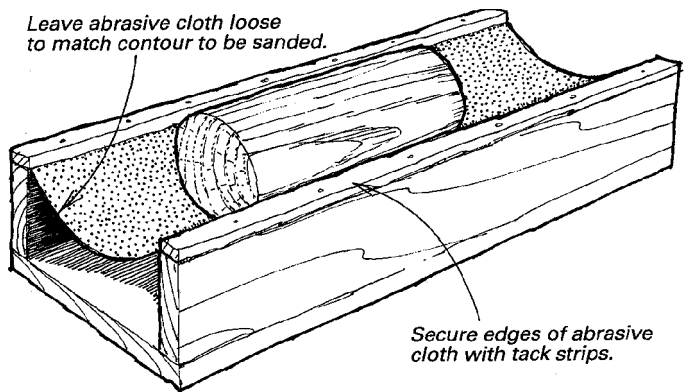

I recently turned a number of wooden mallet heads that came from the lathe with tangential cross-grain sanding marks. I wanted to remove these marks by sanding them out with the grain. To do this, I made a simple box with pine 1x6s and a 12-in.-long section of 6-in.-wide abrasive cloth from a belt

sander. I hung the abrasive cloth with some slack so that it conforms to the curved surface of the cylindrical mallet heads.

—Michael Basisty, Belleville, Ont., Canada

Quick tip: Use a knife steel to burnish the hook on a scraper. The hardened steel rod with fine longitudinal striations gives a "bite" on the scraper that a smooth burnisher lacks. Steels often get separated from the turkey-carving set and show up at flea markets where they can be had for 50 cents or so.

—Kenneth F. Kinsey, Geneseo, NY.

Push stick for ripping narrow strips

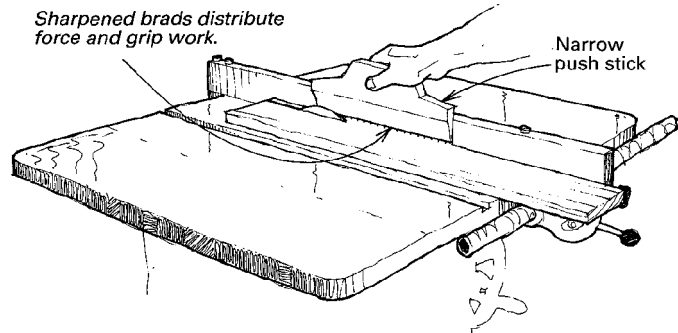

Ripping narrow strips on a table saw felt risky until I improvised a pusher with multiple sharpened brads. With this device, I can push the workpiece forward and, at the same time, press it tightly against the fence to ensure accurate width. The pusher gives me secure control of the wood and also keeps my fingers well away from the saw. Because the force is distributed over multi-

ple points, penetration into the wood is not noticeable.

I have been using this device for 40 years. So the 30 minutes of construction time has given a good return on the investment.

—Richard Koontz, Camp Hill, Pa.

Combination router-table bit guard and stops

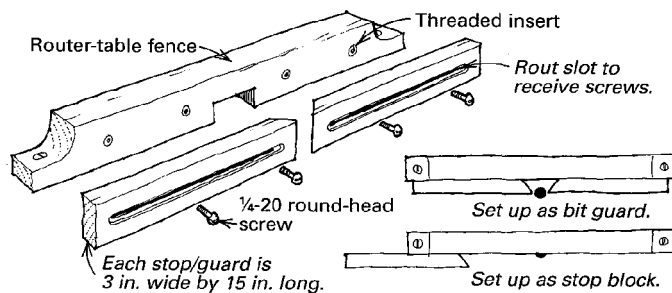

I added two 3-in.-wide, 15-in.-long pieces of hardwood to the fence of my router table. Each piece is mitered on the end closest to the bit and attaches to the fence with round-head screws through a long slot. Now what have I got? First, I have a blade guard, which I can adjust to expose the minimum amount of cutting edge. Second, I have a built-in pair of stop blocks that can be quickly adjusted and locked without clamps.

—Robert Spalter, Lake Worth, Fla.

Methods of Work buys readers' tips, jigs and tricks. Send details, sketches (we'll redraw them) and photos to Methods, Fine Woodworking, PO Box 5506, Newtown, Conn. 06470-5506. We'll return only those contributions that include an SASE.

Clamp for holding mitered molding

Press down on dowel, and slide blocks toward center. Release dowel to apply pressure to molding.

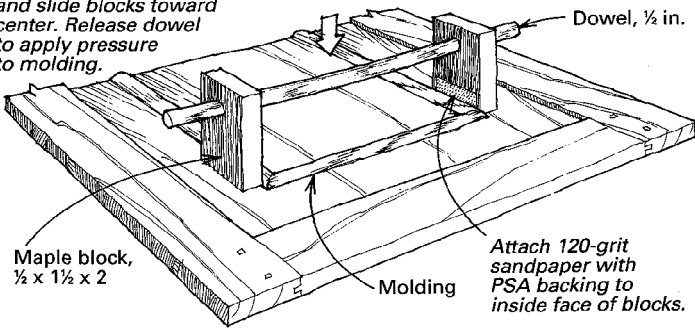

I use these simple, inexpensive and versatile clamps to close the miters on molding applied to cabinet doors. Cut two maple blocks, 1 1/2 in. by 2 in., 1/2 in. thick. Drill through the blocks with a 1/2-in. Forstner bit to make a clean hole. Glue some sandpaper to the inside face of each block. Slide the two blocks, face to face, on a 1/2-in. dowel. To clamp, slide the blocks until they contact the work. Then bend the dowel down, slide the blocks home and release. Voila—pressure! —Rob Hetler, Langley, Wash.

Router table attachment for tablesaw

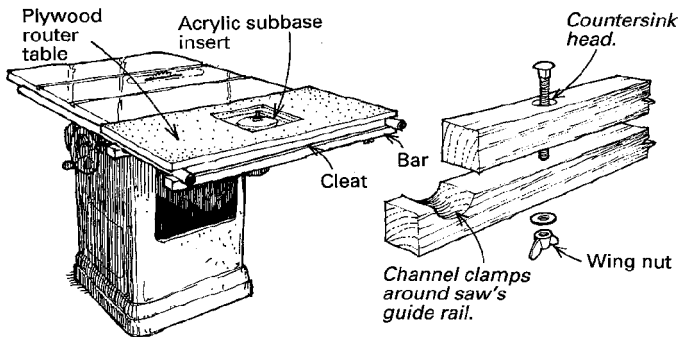

When I began thinking about a router table, it soon became apparent that finding a home for a large, occasionally used table would be a problem in my crowded basement shop. Finally, it occurred to me while looking at the rip fence bars extending from my tablesaw that here was an ideal support system for the router table. In addition, I am able to use the saw's fence and miter gauge for certain operations on the router table.

I cut a piece of 3/4-in. plywood, 16 in. wide and long enough to fit over the bars. Into this, I routed a ledge to accept an acrylic router subbase. I attached wooden cleats to the bottom of the plywood tightly between the bars to prevent front to back movement of the table. A second set of cleats along with bolts and wing nuts clamps the table to the bars.

Although the router-table top extends above the saw-table top, limiting the fence travel to the extreme right of the saw table, the saw can still be used for quite a bit of work with the table in place. When necessary, it takes only a minute to remove the table and hang it against the wall.

—Martin Gingrich, Palmyra, Pa.

Setting plane irons

I have tried sighting across the sole of a metal handplane to set the iron, but I haven't seen a thing but glare. Here is a new way that works.

Stand in a room with your side to a doorway or window that light is coming through. Hold your plane at belt buckle level with the sole vertical and facing away from the light. Sight down the sole toward the throat and slowly advance the iron. As it

emerges, you will see a thin line of light reflecting from the cutting edge. The shape will be a crescent or a straight line, depending on how you have ground your edge. If it is wedge shaped, you need to move the lateral adjuster toward the thicker side to square the cutter to the sole. The thinner the band of light, the less the cutter is exposed and the finer the shaving will be. Be careful not to block the light entering the top of the plane with your hands.

—John Knepper, New Milford, Conn.

Portable flood lights

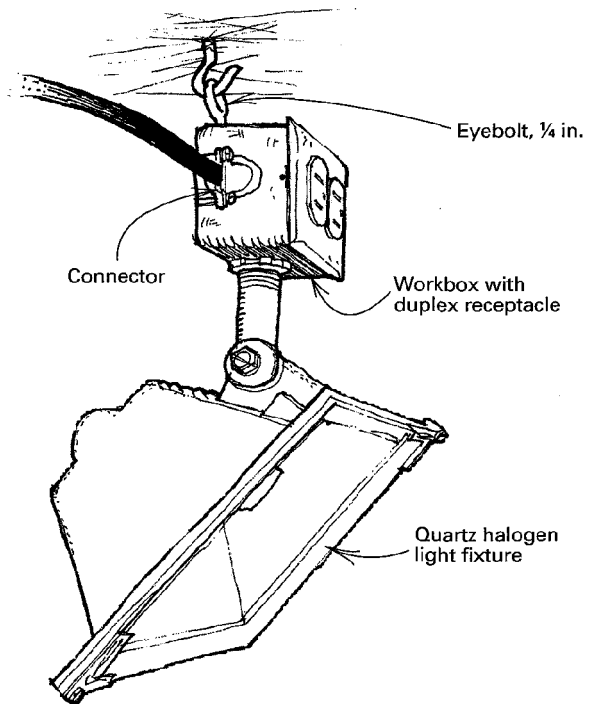

To provide a flexible lighting system in my shop, I assembled several lighting fixtures. Each fixture comprises a 300-watt halogen light, a workbox, a duplex receptacle, a 1/4-in. eyebolt and about 10 ft. of three-wire grounded cord with plug. Screwing 1/4-in. hooks into the ceiling of my shop at key locations lets me move a light to wherever I happen to be working. There is no stand to get in my way, and I always have a receptacle close by for my drill or sander.

—Lester Lavy, Dayton, Ohio

Quick tip: A chalkboard eraser makes a great sanding block. Use the hard side for sanding bare wood and the soft side for sanding out finishes.

—Howard E. Moody, Upper Jay, N.Y.

Standard pencil gauge

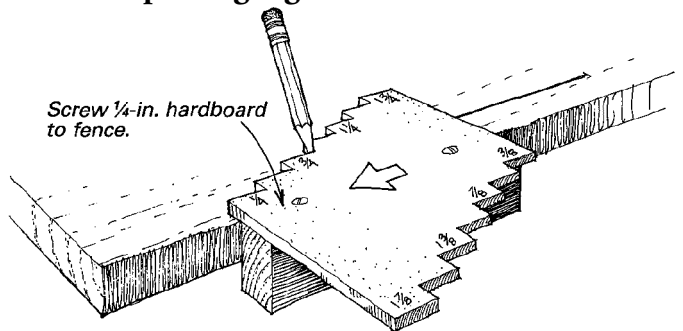

In cabinetry, there are many occasions when you need to mark distances from an edge and some of these recur frequently. This gauge allows you to mark distances from the edge of stock by

drawing with a pencil in the appropriate notch.

The example shown is made from 1/4-in. hardboard screwed to a piece of 3/4-in. square stock. It has notches at 1/4-in. intervals on one side and intermediate 1/8-in. spacings on the other, but you can arrange notches and the size of the gauge to suit your needs.

—Percy W. Blandford, Stratford-upon-Avon, England

Substitute tail vise

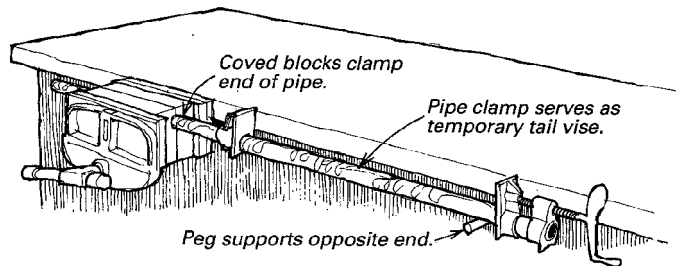

When I found myself in need of a tail vise, which my bench does not have, I designed this substitute that uses a pipe clamp and acts like bench dogs. To make the vise, cut coves in a two-piece block to hold the tail of the pipe clamp in your bench vise and drive a sturdy peg into the edge of the bench to support the other end. The bulk of the workpiece should be supported by the benchtop. You can also turn the pipe clamp 90° to edge-clamp or hold floor-standing workpieces upright.

—Tony Konovaloff, Bellingham, Wash.

Push stick for thin workpieces

Specialty push stick holds thin workpieces down on saw table and against fence.

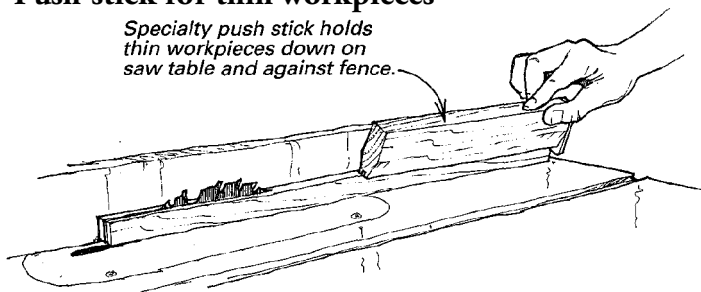

This push stick is customized for pushing long thin pieces, such as picture-frame parts, through a sawblade when ripping or rabbeting. The sawkerf presses on the upper outer edge of the work, holding it both down and against the fence. The length of the pusher allows it to bear against the whole length of most workpieces. The stop screwed to the end of the pusher should protrude just enough to hook over the end of the work and push it along.

—Abijah Reed, Newton Center, Mass.

Temporary workbench top

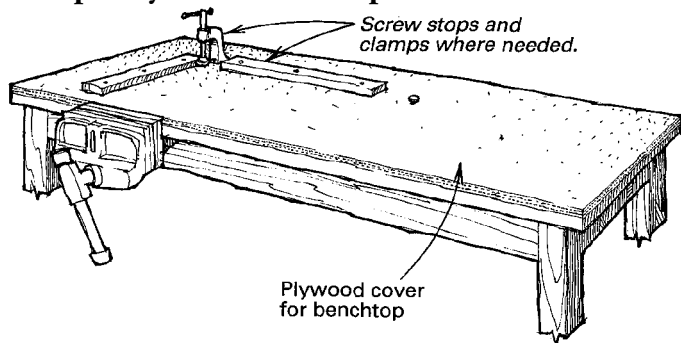

I attached a piece of 3/4-in. plywood to the top of my workbench so that I could use hold-down clamps for a special project. Since then, I've discovered that this plywood top, by giving me the

freedom to screw jigs, stops and fences anywhere I like, has changed the way I work. For example, I install standard hold-down clamps anywhere I need them by simply screwing large pan-head screws into the plywood benchtop. The possibilities seem to be endless. Once the job at hand is completed, I remove the screws to return to a normal flat work surface. And if I want to return to the pristine surface of the original bench, I remove the plywood.

—Oscar Williams, Lincoln, Neb.

Quick tip: When a can of paint has been unopened for a few months, turn it upside down for a couple of days before opening. You will find when you open the can that the mixing process is almost complete.

—Herman J. Fersenheim Jr., Woodstock Valley, Conn.

Keeping a paint-can lid dry—revisited

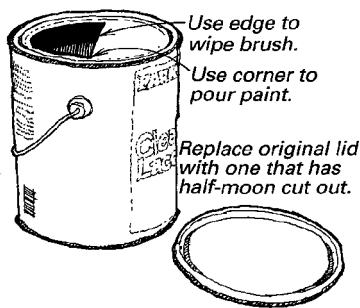

When I open a can of paint, I set the lid aside. In its place, I attach a previously used lid with a semicircular hole in it. The best shape for the opening is a half moon, with a straight edge near the middle and a curve following the outer edge of the rim—not too close, though. I stick my brush into the paint through the opening and use the flat

edge to scrape excess paint from the brush. Or I pour the paint using the opening's corner. Through all this, the sealing lip of the can is protected from drips and remains clean. When I'm through, I just reattach the original lid. If the paint is used up, I save the lid for a future cutout.

—Ronald R. Schultze, Redlands, Calif.

Scissor jack router lift

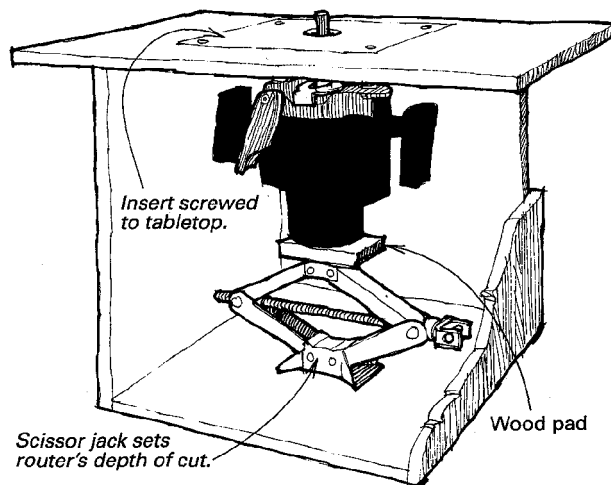

After looking through catalogs and saving my pennies, I finally located the perfect plunge router for my router table—or so I thought. After mounting it in the table, it became obvious that depth adjustments were difficult because I had to fight both the motor weight and the stiff plunge springs.

Using an automotive scissor jack is the solution that I've found. I place the jack below the router on a fixed shelf, mounting a small pad of wood on the top of the jack to protect the router. The only other change is to screw the drop-in insert to the table so that the jack wouldn't push it out of the hole. Now I can set the depth of cut easily and accurately by turning the jack screw

with my fingers. When I have the right depth, I lock the router's plunge mechanism in that position and get on with routing.

—Mark G. Carls, Juneau, Alaska

Quick tip: To make perfectly sized dowels, cut 6-in. lengths of regular birch dowel, and with the lengths chucked in a drill press running at its slowest setting, feed the dowel slowly and steadily through a predrilled hole in a chunk of scrap maple or oak. This operation compresses and burnishes the dowels for a perfect fit. Move to a new burnishing hole after half a dozen dowels. I chamfer the dowel ends with a belt sander, and then I cut a couple of longitudinal kerfs in each dowel to act as glue vents.

—Tom Rose, Los Angeles, Calif.

Double-duty clamp stand

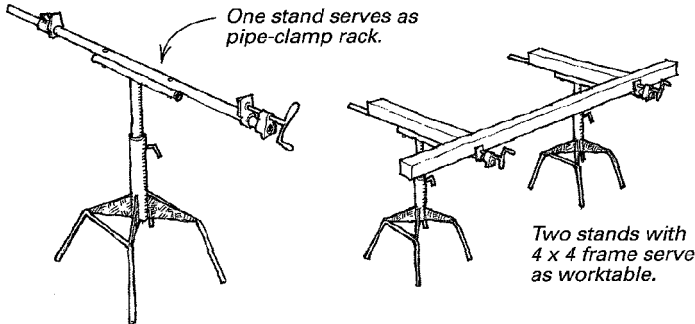

These stands serve not only as a clamping rack but also as a plywood worktable. Make the stand by bolting a Jorgenson pipe clamp to the T-top of a work support stand. To use as a clamp-

ing rack, simply lay down the boards, and tighten the clamps. Add other clamps on the top and bottom if needed. To use as a worktable, clamp a long 4x4 into the stands using a couple of shorter 4x4 crosspieces to form a frame.

—K. O. Brown, Bessemer, Mich.

Marking stretcher hole locations in round legs

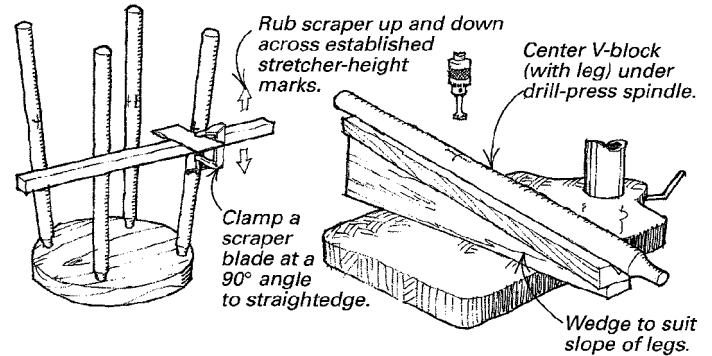

Here's how to accurately mark the location of stretcher holes in round legs. First dry-assemble the stool or chair and upturn it on the bench. Mark the stretcher height locations on the legs with horizontal lines. Now clamp a scraper blade to a straightedge at a 90° angle, and rub this tool up and down the legs to make a scratch mark, as shown in the sketch. Remove the legs, and mark the center of the drilling where the scratch mark crosses the height line.

To drill the hole, clamp a long V-block on the drill-press table centered under the spindle. Use a wedge to incline the V-block

at the same slope as the legs. Place the leg in the V, rotate it to center the mark under the bit and then drill.

—Nigel Atkinson, Long Whatton, Leics., England

Quick tip: To remove broken dowels without damaging the original hole, drill a hole through the center of the broken dowel, and fill it with water with a touch of dishwashing detergent. The water and soap (penetrating agent) will soak through the wood, dissolve the old glue and make it easy to remove the old dowel.

—Bruce De Benedictis, El Cerrito, Calif.

Removable cabinet panels

Cut head off one side of clothespin, tail off other.

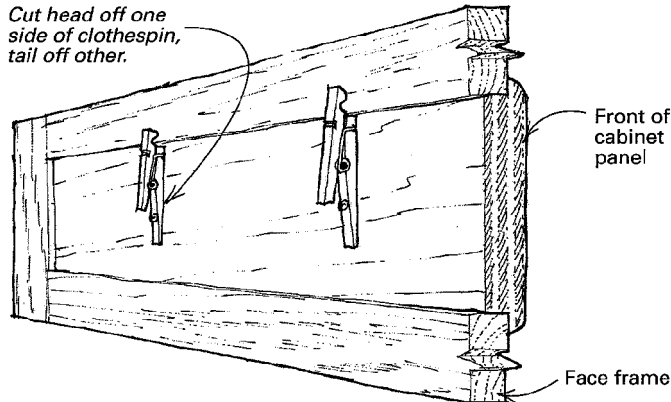

Here's how to fasten a blank cabinet panel like the one in front of the kitchen sink, so it can be easily removed. Alter a regular spring clothespin by cutting off the top of one side and the tail

of the other. Now, using a single screw for each pin, fasten a couple of the altered pins to the back of the panel. Set the panels in the hole, and reaching in from behind, rotate the pins so they spring open and grip the frame.

—Lewis A. Larsen, Eagle Grove, Ia.

Odd angled clamping

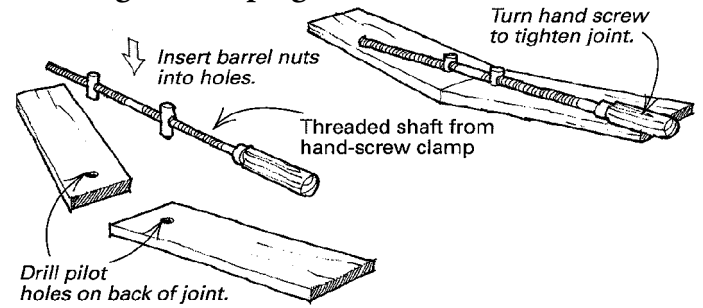

I use the hardware from wooden hand-screw clamps to draw odd angled joints together as they are glued. Simply drill pilot holes on the back side of the joint with a Forstner bit that is the same size as the clamp's two barrel nuts. Drill deep, but don't go through the workpiece. Insert the nuts into the two pilot holes, and close the joint tightly by rotating the hand screw.

—Dick Dorn, Oelwein, Ia.

Methods of Work buys readers' tips, jigs and tricks. Send details, sketches (we'll redraw them) and photos to Methods, Fine Woodworking, PO Box 5506, Newtown, Conn. 06470-5506. We'll return only those contributions that include an SASE.

Combination horizontal and vertical router table

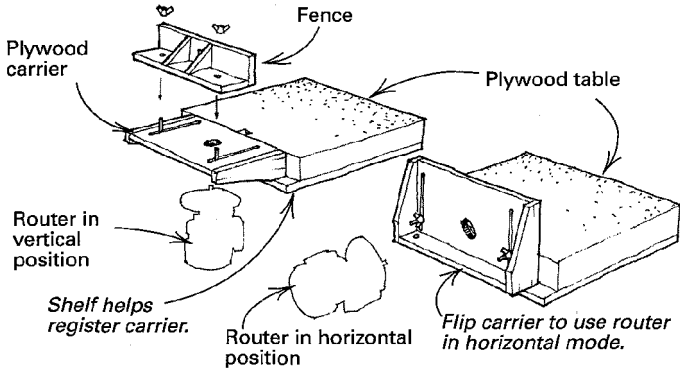

I made this combination router table so that I could quickly switch the tool from the traditional vertical position to a horizontal position for making raised panels and sliding dovetails. The basic concept behind the table is the demountable 3/4-in. plywood L-shaped router carrier, which has mating sets of mounting holes on each leg of the L. One set of the mounting holes are slotted so that the router may be adjusted up and down in the horizontal position. In the vertical position, the slotted holes allow in-out adjustment of the router's fence. Note that the fence, which normally faces the long end of the table, can be reversed to face the short end of the table for small pieces.

—Andrew Westerhaus, Burnsville, Minn.

Cabriole leg jig

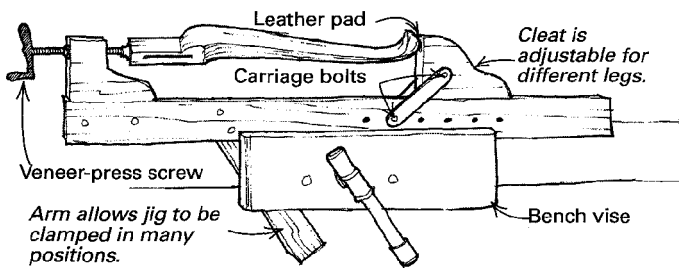

This jig, which I have used for more than a year, is much more comfortable for shaping cabriole legs than the grooved blocks, pipe-clamp fixtures and other devices I have cobbled together from time to time. I can easily rotate the work by loosening the screw at the headstock end. Or by changing the jig's arm position, I can orient the workpiece anywhere in the bench vise—horizontal to vertical. The vertical position permits much easier filing and scraping of the top of the foot. This particular jig is a few inches over 4 ft. long and made from 2 1/4-in.-thick solid stock

—A. Wallace Root, Berwyn, Penn.

Eliminating miter-gauge side play

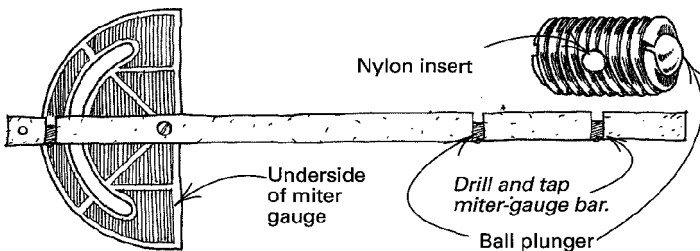

Here's another method for eliminating miter-gauge side play to add to those listed in Daniel Westberg's article (FWW#93, p. 74). This inexpensive method uses ball plunger screws inserted transversely to the bar at three locations. The plungers are threaded steel inserts fitted with spring-loaded stainless steel

balls. I use the heavy force plungers (2 to 5 lbs. end force), 10-32 threads, 1/2 in. long, with nylon locking element (available from MSC Industrial Supply Co., 151 Sunnyside Blvd., Plainview, N.Y. 11803-1592). Drill three holes through the bar, two near the tip and one near the base, and tap for the threads. Screw the plungers into the holes with the balls facing the same direction. Use a screwdriver to adjust the plunger depth until all side play is removed without excessive friction or interference. The plunging action of the balls will compensate for any variations in the saw table's slot width.—Richard Shultz, Cinnaminson, N.J.

Improved taper jig

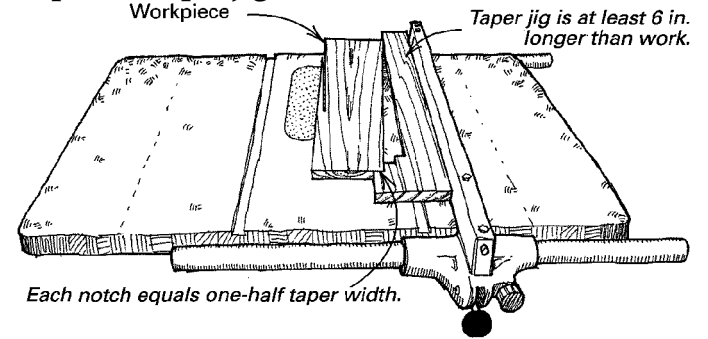

The tapering jig I use for short runs is just as quick to make as Phil Dark's (FWW#98, p. 20), but it also handles longer workpieces and provides more control and safety. I simply cut three notches into a scrap piece that's 6 in. or so longer than the workpiece to be tapered. The width of each notch is one-half the taper. For longer runs or if the final taper is too small to hold securely and safely, I attach the jig to a substrate and use DeSta-Co toggle clamps to hold the workpiece firmly.

—Tai Lake, Holualoa, Hawaii

Quick tip: To flush trim dowel plugs without scoring the work surface, hone the last few inches of one side of a coarse hacksaw blade to remove the tooth set. Saw off the dowel stub with the honed side against the workpiece, and then trim the dowel with a sharp chisel.

—Peter Burrage, Essex Junction, Vt.

Plywood-lifting sawhorse for the tablesaw

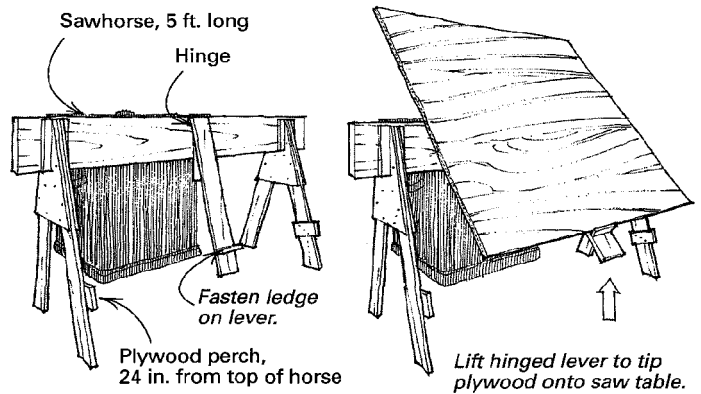

Because it was awkward and difficult for me to hoist a full sheet of plywood onto my tablesaw, I made this special sawhorse. The unique part of the sawhorse is the center lever. It is hinged at the top and has a ledge at the bottom so that I can easily tip the plywood onto the saw table for cutting. Blocks screwed to the legs of the sawhorse provide a perch for the plywood. The blocks and the ledge are 24 in. from the top of the horse so that a full sheet will balance and tip easily. I made the horse 5 ft. long and the same height as the saw so that it supports the out-

er edge of the plywood during the cut. To save space, I knock down the sawhorse when it is not in use.

—David C. Hurd, Madison, Wis.

Beltsanding large concave surfaces

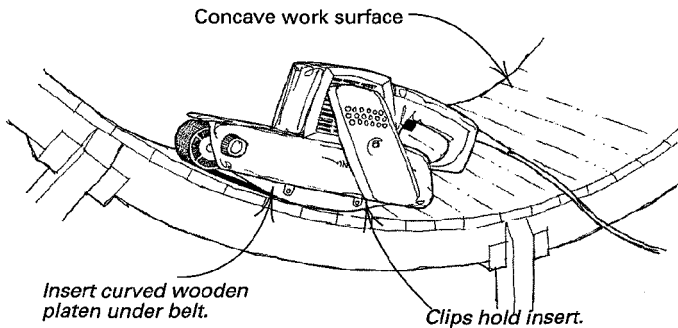

To beltsand large concave surfaces, make a curved wooden insert as wide as the sander's platen to go under the belt. Slightly flatten the insert's crown to get more of the sanding belt in contact with the surface. There's a limit to the thickness of insert you can use; you've gone too far if the belt-release mechanism doesn't close properly. The insert should stay in place without any type of attachment. If it doesn't, use clips to secure the insert.

—Chris Marley, Kingston, Jamaica

Darkening the finish on brass hardware

If you don't want that shiny gold color on new brass hardware, here's a method one of my instructors taught me to add a nice

antique patina on brass using household ammonia.

First remove any clear coating from the hardware; then wipe the surface with alcohol, taking care not to leave any fingerprints. Set the hardware aside, and prepare a clean large-mouth jar as follows: Attach a wire to the lid that will hold the hardware off the bottom of the jar with room to spare. Place a few hardwood shavings into the jar, and pour in about $\frac{1}{4}$ -cup ammonia. With the hardware attached, screw the lid onto the jar. The amount of color will depend on the fuming time and the type of brass alloy: Figure on at least two and up to 10 hours. Harder brass alloys, such as those used in screws, will not darken much at all. After the fuming process, wash the brass with water and apply some wax. If the color is too dark, you can easily buff the metal and start again.

—Tony Konovaloff, Bellingham, Wash.

Wooden spring hold-in

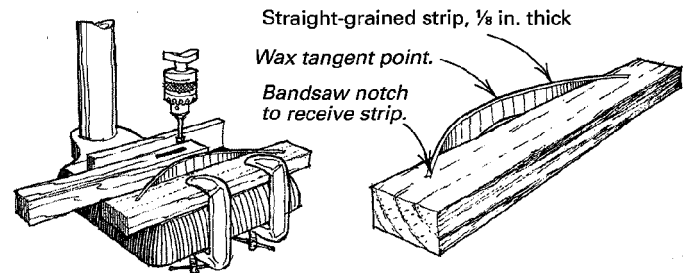

I often cut mortises on the drill press with a Forstner bit. To favor an arthritic condition in my left hand, I came up with this wooden spring hold-in to push the workpiece against the drill-press fence. I clamp it to the drill-press table with the crown of

the spring tangent to and pushing against the workpiece at the drill center. The hold-in pushes the workpiece firmly against the fence but allows smooth, easy side-to-side movement. A little wax on the tangent point of the spring helps.

—C. Henry White, Bristol, Va.

Quick tip: After cleaning a paint brush with solvent, comb through the bristles with a cheap hair comb. This straightens the bristles and removes hardened particles of finish left in the brush.

—John Hensel, Los Angeles, Calif.

Chopsaw stop block

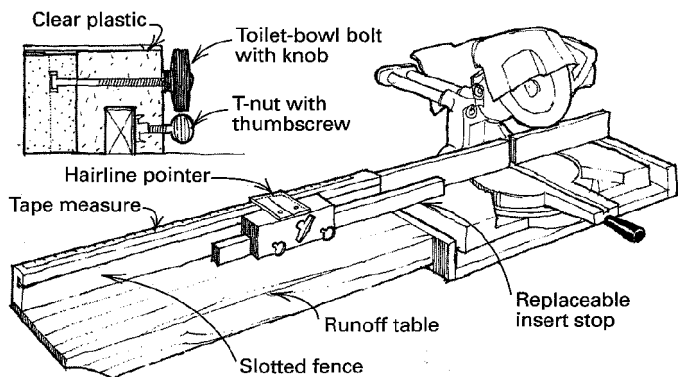

This chopsaw stop block has worked wonderfully for me. It speeds up my crosscut work significantly, and I never use a tape measure at the saw anymore. A special feature of the stop block is the replaceable insert, which ensures perfect-length cuts. To

align the stop, set the hairline pointer (marked on a piece of clear plastic) to zero, slide the insert past the sawblade, tighten everything up and cut off the insert, which zeroes it. Now you can slide the pointer to whatever measurement you need, tighten the stop-block knob and cut with confidence.

—Lars Mikkelsen, Santa Margarita, Calif.

Oval shaped spindles

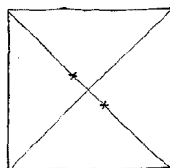

1) Mark centers on stock equidistant from intersection of diagonals.

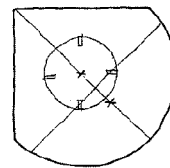

2) Place headstock and tailstock on mating marks and turn.

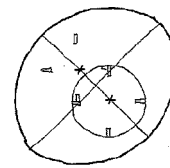

3) Move headstock and tailstock to other marks and turn.

Here's how I turn oval-shaped spindles, which I first used in quilt racks. Determine the finished dimensions of the oval profile. Remember that you will be turning work off center, so don't overdo the differences in the dimensions. For example, on a 1-in. spindle, I'd start with a difference of $\frac{1}{4}$ in. and certainly not more than $\frac{1}{2}$ in.

Cut your stock exactly square and about $\frac{1}{16}$ in. wider than the larger dimension to allow for sanding. Draw accurate diagonals across the ends. Then, from the center, taking care to use the same diagonals on each end, measure out half the difference and mark. This will give you two marks on each end, one on each side of center. Drill pilot holes on the marks so that the

placement of the headstock and tailstock will be accurate. Round the corners of the workpiece to save unnecessary vibration when you start.

Place the spindle in the lathe with the points of the headstock and tailstock in one set of the off-center pilot holes. Turn until half the spindle is round. Move the workpiece to the other set of pilot holes, and turn until you reach the profile you turned first. File and sand the oval spindle while it is still on the lathe.

—James A. Johnson, Brunswick, Ohio

Circle jig for the bandsaw

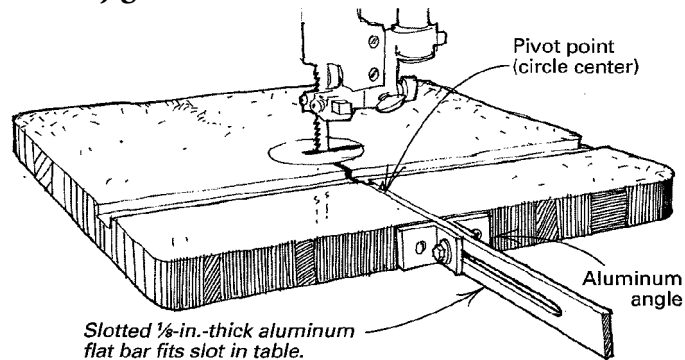

This bandsaw circle-cutting jig, which uses the blade-mounting slot in the saw's table, is made of readily available $\frac{1}{8}$ -in.-thick aluminum flat bar and angle. The pivot point is the shank of a broken $\frac{1}{16}$ -in. drill bit, pointed on a grinding wheel while being held in a drill motor. Construction is straightforward, as shown in the sketch above. Drill and tap the side of the bandsaw table

to hold the angle clips. You can cut the slot in the adjustment bar with either a jeweler's saw or with a power jigsaw. This jig will cut circles from $\frac{1}{2}$ in. to 16 in. To cut the larger circles, simply reverse the adjustment bar in the slot. When not in use, store the bar with the pin pointing down.—Ronald E. Young, Decatur, Ala.

Quick tip: GOOP hand cleaner, sold in auto parts stores, will remove furniture stain from your hands as effectively as mineral spirits but without the drying effect.—Ed Warwick, Swansea, Ill.

Hiding bed bolts revisited

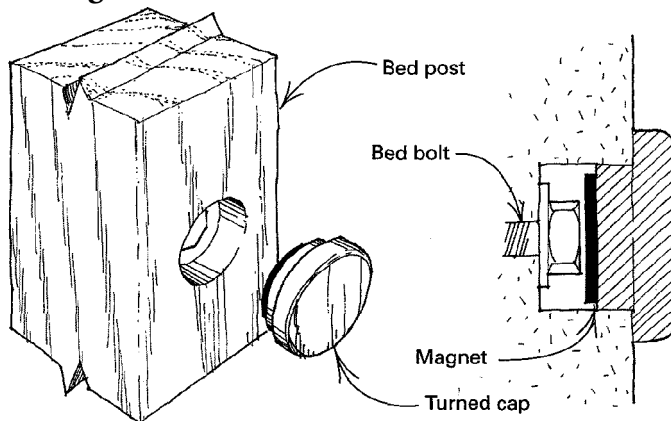

Another method of hiding bed bolts involves using a magnet. Before drilling the bolt holes, drill somewhat larger holes approximately $\frac{3}{8}$ in. deeper than the thickness of the bolt head and washers. Then turn a set of wood caps that snugly fit the holes.

Glue a small, flat magnet to the back of each cap to hold it against the bolt heads. The caps are easily removed if necessary, but the remainder of the time, they neatly cover the hardware. The cap's dimensions can be varied, the style changed or even carved for a different look. —Ken Schroer, Panama City, Fla.

Shop vacuum from a leaf blower

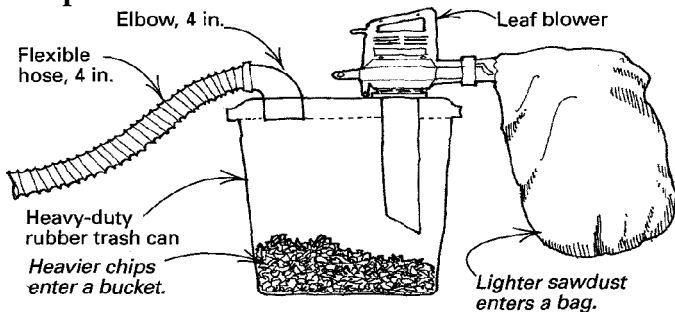

Neither having the space nor the budget for a large dust collector, I fabricated a powerful two-stage unit for less than \$100. A two-speed electric leaf blower is the heart of the system. I insert the vacuum tube of the blower into a carefully cut hole in the tightly fitting lid of a heavy-duty rubber garbage can. The vacuum inlet, which sits in a snug opening in the lid, is a 4-in. elbow salvaged from a clothes dryer. A 4-in. flexible hose completes the connection to any tool.

Because the unit is two-staged, the heavier chips fall into the can while the dust flows into the bag. The unit is lightweight, easily moved to any machine in the shop and powerful. So powerful, in fact, that I've had to build an internal frame for the garbage

can to keep it from collapsing under the vacuum. Best of all, the vacuum is easily converted back to a leaf blower by simply removing the vacuum tube from the lid of the garbage can.

—David A. Hill, Simsbury, Conn.

Quick-Grip clamp bracket

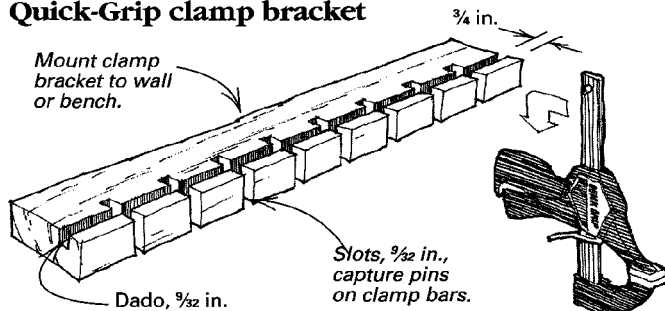

Everyone I have talked with loves American Tool Companies' new Quick-Grip clamps. Here's a simple hanger bracket that efficiently stores the awkward-to-hang clamps. Using a couple of side-by-side sawcuts, dado a groove just over $\frac{1}{4}$ in. wide and as deep, about $\frac{3}{4}$ in. from the edge of a board. Then cut slots, again just wider than $\frac{1}{4}$ in., into the board every couple inches or so. Mount the board on the wall or under the end of your workbench. Hang the clamps in the slots by the little compression pins in the ends of the bars.—Lloyd W. Wood, Virginia Beach, Va.

Methods of Work buys readers' tips, jigs and tricks. Send details, sketches (we'll redraw them) and photos to *Methods*, Fine Woodworking, PO Box 5506, Newtown, Conn. 06470-5506. We'll return only those contributions that include an SASE.

Folding sawhorse

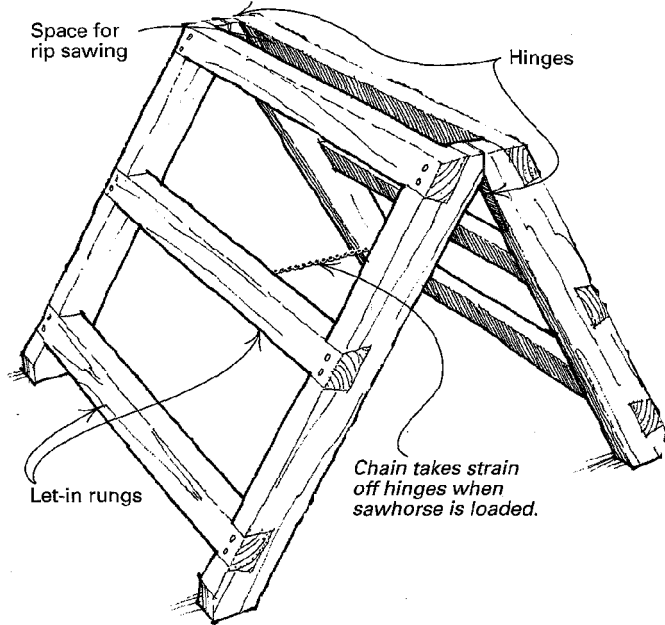

After experimenting with many sizes and shapes of sawhorses over the years, I finally designed and built this folding horse, which is easy to store and transport. When opened, it serves as a steady horse with a rip saw space at the top. It also doubles as a sturdy step ladder. Two horses can support low scaffold planks or a workbench top. An added bonus is the clean design, which makes the sawhorse attractive and easy to construct.

To make the horse, dress 10 pieces of pine 1½ in. by 3 in. by 30 in. long. Bevel-rip six of the pieces at 30° for the steps. To mark out the notches and angle cuts on the four legs, first make an accurate template of thin plywood. To ensure rigidity, cut the leg notches carefully to receive a press fit. Press the steps into the leg notches with bar clamps, and fasten with countersunk flathead screws. You may wish to round the exposed edges of all pieces to reduce splintering and improve the looks.

Now mount the hinge. This may be easier to do if you remove the hinge pin, mount the hinge halves and then replace the hinge pin after lightly peening for a tight fit. Fasten a suitable chain between the centers of the middle steps to take the strain off the hinges when the horse is used under load.

—H. M. Smith, Napanee, Ont., Canada

Plywood roller

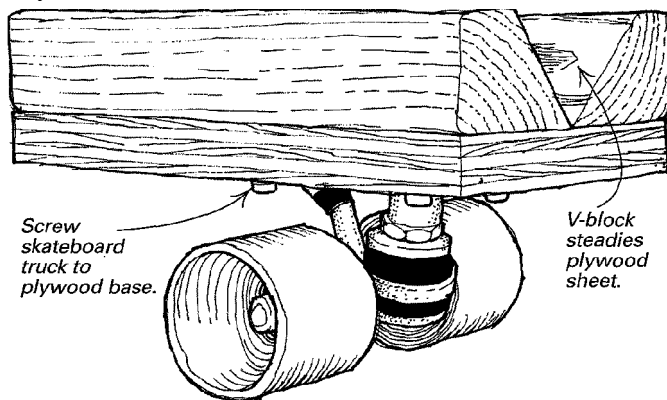

For the expenditure of a few bucks and a few minutes, you can roll those plywood sheets instead of carrying or dragging them.

Screw a couple of beveled 2x4s to a chunk of ¾-in. plywood to make the V-grooved base. Then mount a skateboard truck to the bottom so that the wheels are centered.

—Thomas K. Wilson, San Diego, Calif.

Sawblade stabilizers

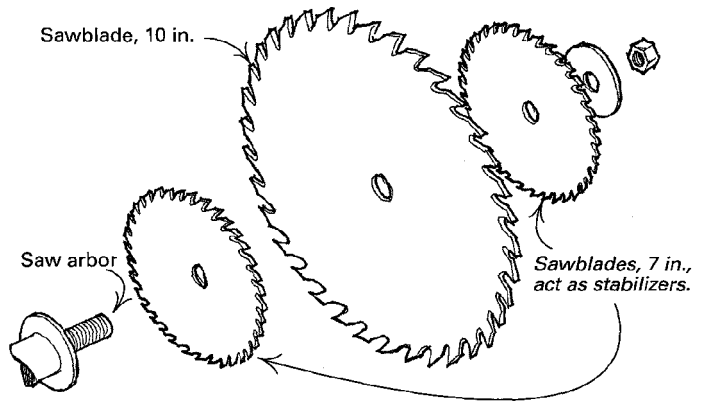

When I began experiencing some blade wobble and vibration problems on my tablesaw, I looked into but rejected a set of expensive mail-order blade stabilizers. Later, I noticed a couple of used 7-in. circular sawblades hanging around the shop waiting to be sharpened. I sandwiched my 10-in. tablesaw blade between the two smaller blades around the shop waiting to be sharpened. I sandwiched my 10-in. tablesaw blade between the two smaller blades to act as a stabilizer. The arrangement solved my blade wobble and vibration problems. I'm sure that smaller diameter blades, which would provide a greater cutting depth, would also work effectively.

—Les Barna, Indialantic, Fla.

Adjustable vise mount

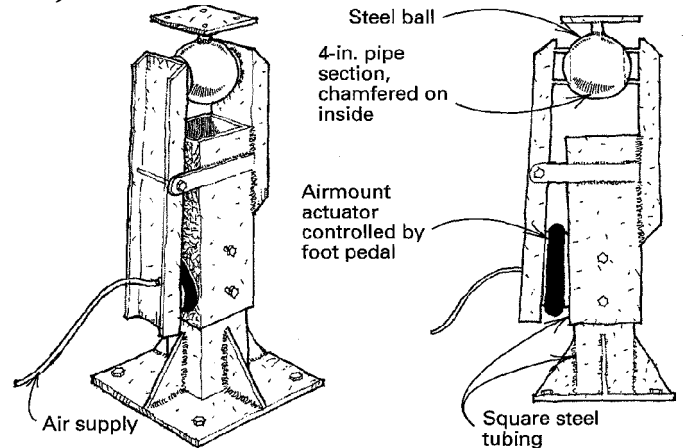

I needed a way to mount and hold sculpted chairs at odd angles while I was working them with a pneumatic drum sander. The device I finally came up with works great for this purpose, and it makes an effective adjustable vise mount or carver's screw mount. For the pivoting head, I used a steel ball made at a ball mill. A bowling ball would probably work just as well. Chamfered 4-in. pipe on either side holds the ball in place, as shown in the drawing above. I welded the stand from sections of heavy-gauge square steel tubing and plate. I then bolted the base plate to the floor.

There are two ways to provide the clamping leverage: a regular bench screw or an Airmount air actuator. The actuator, available through industrial air equipment suppliers (call Firestone Industrial Products at 317-580-2300 for information), is basically just a tire between two steel plates. Add air, and it tightens the grip on the pivoting head. The device is perfect for this application

because it exerts tremendous force on the ball (about 1,000 lbs. at 40 psi), and it puts up with lots of angular misalignment. I installed a foot-pedal air valve so that both of an operator's hands remain free to adjust the stand. —Chuck Waugh, Boring, Ore.

Quick tip: When dowel pins are too tight for comfort, bake the pins in a 200° oven for several hours. The pins will shrink just enough to fit easily during assembly, but during glue-up, they will swell to their original size to make a tight joint.

—David J. Loy, Columbus, Ohio.

Dowel-slotting jig

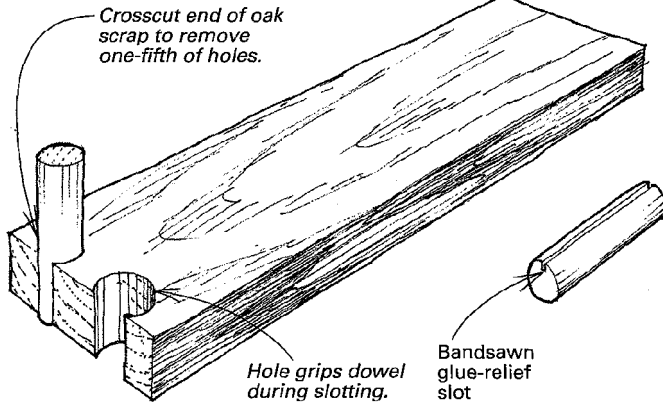

This simple jig has but one purpose: to help in cutting a glue-relief slot in regular lumberyard dowels. To make the jig, simply drill a couple of dowel-sized holes near the end of a beefy scrap

of oak. Then crosscut the piece removing about one-fifth of the hole, leaving four-fifths to grip the dowel. Now insert pre-cut dowel pins in the proper-sized hole, and push into the bandsaw to slice a shallow slot. —Steve A. Balla, Bramalea, Ont, Canada

Shaping curved-top panels

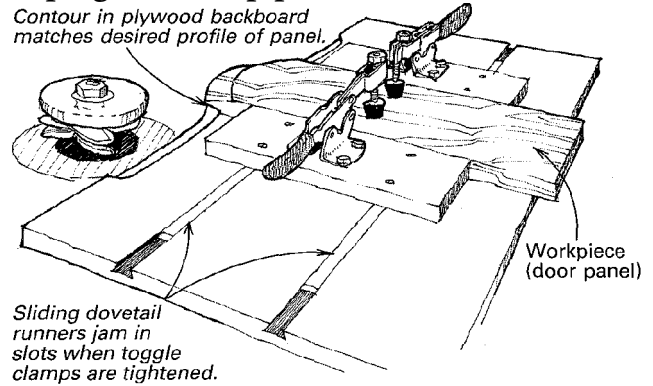

When shaping curved-top panels for cathedral-top cabinet doors, I use the standard approach—a plywood jig with a curved contour cut into its top, which guides along a ball-bearing rub collar mounted below the shaper cutter. But for the jig to work properly, you have to eliminate any side-to-side movement in the workpiece as it's being shaped. My original solution to the problem was to use fixed blocks attached to the plywood jig on either side of the workpiece with DeStaCo toggle clamps mounted on the blocks. I would cut filler strips to wedge between the blocks and the workpiece to center the work and to

keep it tight. As the panel widths changed from door to door, I would cut new filler strips. Any panel that went beyond the capacity of the toggle clamps meant that I had to unscrew the blocks and reposition.

Finally, I redesigned the jig by mounting the plywood blocks to sliding dovetail runners. After centering the workpiece, I slide the blocks into position on either side of the workpiece and toggle the clamps down. The clamping pressure lifts the sliding dovetails, which wedges them into the slots and clamps the whole thing tightly. Then I'm ready to shape.

The combination of sliding dovetails and toggle clamps has promise for holding down materials in other applications, too.

—Tom Griffin, Dublin, Calif.

Quick tip: Slip a short length of split garden hose on the wire handles of plastic buckets to make them more comfortable to carry. Wrap electrical tape on each end to keep the hose in place.

—John A. Wilson, Lexington, Mass.

Yardstick stop block

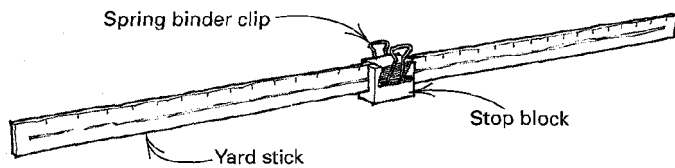

To reproduce measurements that exceed the capacity of your combination square, make a simple stop block for a yardstick. Attach and adjust the block with a spring binder clip.

—Harold D. Rodden, Florissant, Mo.

Router circle-cutting simplified

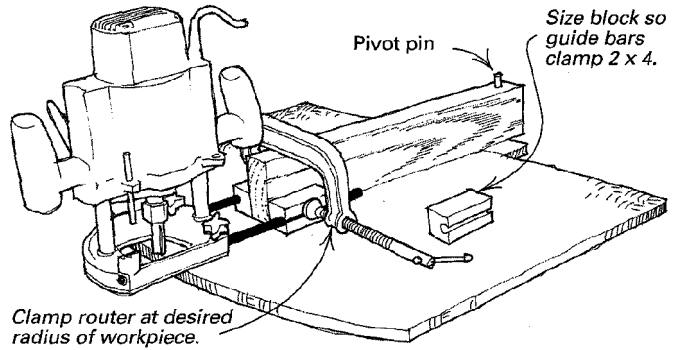

Although I've seen dozens of methods for routing circles over forty years of woodworking, the method I stumbled on early is still the least complicated and quickest I've seen.

Two small hardwood blocks kept right in the router storage case are the heart of the method. The blocks slip on your router's guide bars leaving a bit of the bar exposed, as shown in the sketch above. When the blocks are in position, the distance between them should be $1\frac{1}{8}$ in., the thickness of a 2x4, so that any length ripped from a 2x4 can be used to size the radius of the circle to be cut.

To cut the circle, drill a $\frac{1}{4}$ -in. pilot hole in the 2x4, and use a dowel or $\frac{1}{4}$ -in. bolt on a block as a pivot. Or just drive a nail through the 2x4 if the hole won't show. Adjust the router so the bit is in position; then clamp the 2x4 between the blocks and the guide bars with a C-clamp. The open holes in the blocks allow the pads on the C-clamp to pull up tight on the guide bars with-

out slipping off. With this system, you can rout circles as small as 6 in. to as large as...now let's see, what's the length of a 2x4?

—Tim Hanson, Indianapolis, Ind.

Fluting fixture

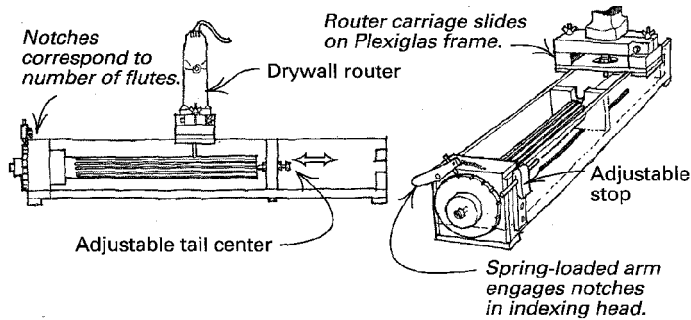

Fluting is an operation that is so seldom required that it does not warrant buying special equipment for the purpose. So when I needed to flute some short columns, I made this fluting fixture from a drywall-trimming router, hardwood scraps and Plexiglas. The construction details shown in the sketch can easily be modified for your particular needs.—Harry J. Gurney, Taunton, Mass.

Installing drawer fronts

Installing drawer fronts in European-style cabinetry (where drawers and doors are flush with the surrounding frame) can be tedious. To look right, the drawer front must be centered in the space with a perfectly uniform gap on all sides. This technique

makes the installation fast and foolproof. With the drawer box installed in the case, temporarily position the front so that the gap, top and bottom is equal. I use metal rulers of various thicknesses as shims to adjust the vertical spacing. Leaving the shims in place, pull out the drawer front, and apply a couple of beads of gap-filling Super Glue to the back. Give the drawer box a spritz of accelerator. Position the parts together, eyeballing the side-to-side spacing. In about 20 seconds, you can open the drawer and install screws to permanently attach the front.

—Andrew Jacobson, Petaluma, Calif.

Clamping with metal strapping

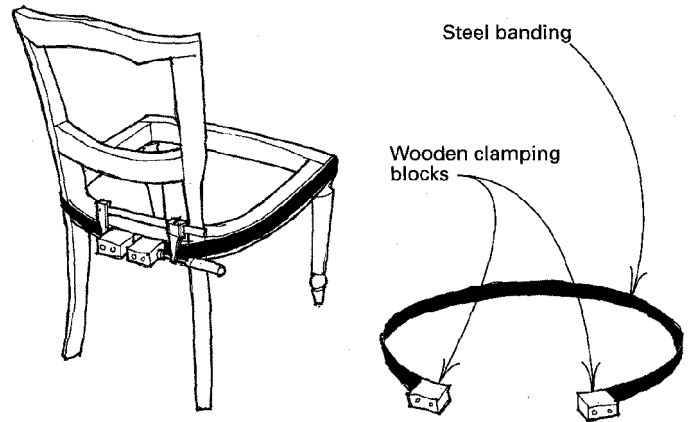

When I needed a large number of expensive webbing clamps for a run of chairs, I improvised this clamp. First retrieve a sup-

ply of metal strapping from the lumberyard scrap bin. Cut the strapping to the approximate length needed. Attach wooden blocks to each end with $\frac{3}{16}$ -in. bolts and nuts. Use a C-clamp or Quick-Grip clamp to tighten. —Chris Marley, Kingston, Jamaica

Quick tip: When repairing antiques or patching veneer, it is often useful to see the repair as you apply clamping pressure. To accomplish this, place a piece of $\frac{1}{4}$ -in.-thick clear plastic between the joint and the C-clamp. Wood glue will not stick to most plastics. —J. Francis Pfrank, Schaumburg, Ill.

Radial-arm saw tips

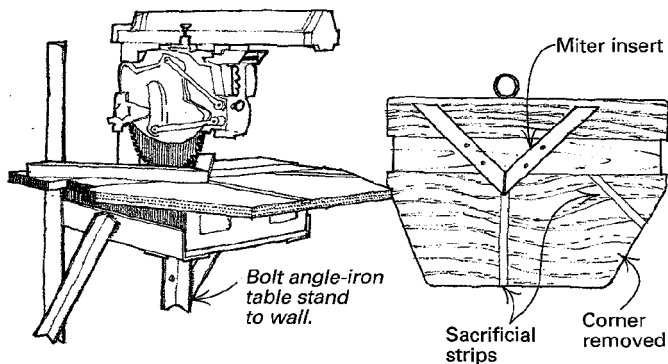

The radial-arm saw is a well-used tool in my workshop, but a few simple modifications have increased its utility even more. The modifications are aimed at reducing the space for the machine itself, increasing the life of the wooden table and making

miter cuts easier to make and more accurate as well.

The first idea is deceptively simple—I cut the corners off the front of the wooden table. The saw's table needs to be quite long at the back, near the fence, but the front is rarely used. So losing the corners makes moving the machine a lot more pleasant without affecting its ability to support the timber being cut.

The second idea is more involved because I have thrown away the legs and mounted the machine on the wall 48 in. from the floor using welded up angle-iron brackets as shown. This sounds rather tall, but after the initial "shock period," I have found it easy and pleasant to use. Mounting the machine this way creates valuable space underneath the machine, which I use to store another tool when I need floor space.

To ensure good support underneath the cut, I have routed trenches $\frac{3}{4}$ in. wide by $\frac{3}{16}$ in. deep along both the 90° and 45° cuts. These grooves are filled with well-fitted hardwood strips held in place with double-sided tape. I prepare several pieces of these "sacrificial" strips at the same time and fit a new one when support is particularly needed.

To cut miters, I remove the insert behind the main table and replace it with the fixture shown in the sketch. Leaving the arm in the 90° position, I miter the first piece by holding it against the left fence. The second piece is mitered using the right fence. Even if each angle is not exactly 45°, as long as the fixed angle between the fences is 90°, perfect miters are achieved.

—John Burchett, Copnor, Portsmouth, England

Methods of Work buys readers' tips, jigs and tricks. Send details, sketches (we'll redraw them) and photos to *Methods*, Fine Woodworking PO Box 5506, Newtown, Conn. 06470-5506. We'll return only those contributions that include an SASE.

Follow up: push stick for rabbeting thin pieces

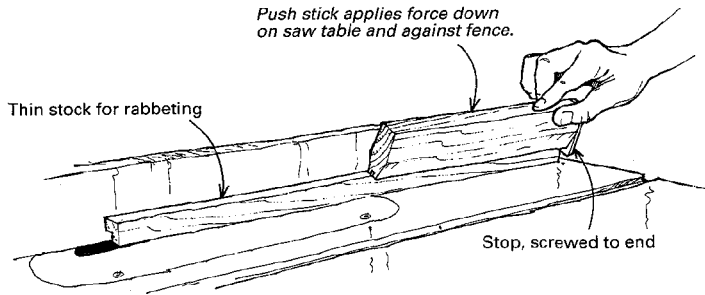

In the August, 1993 "Methods of Work" (*FWW* #101, p. 18), we showed Abijah Reed's custom push stick for advancing long, thin pieces, such as picture frame parts, through the saw. We incorrectly illustrated the device being used for ripping a thin piece. The intended use for the push stick, as Mr. Reed and others have pointed out, is strictly for slotting or rabbeting, as shown in the drawing above. The blade should not protrude above the workpiece. —Alec Waters, assistant editor

Chopping mortises for wedged tenons

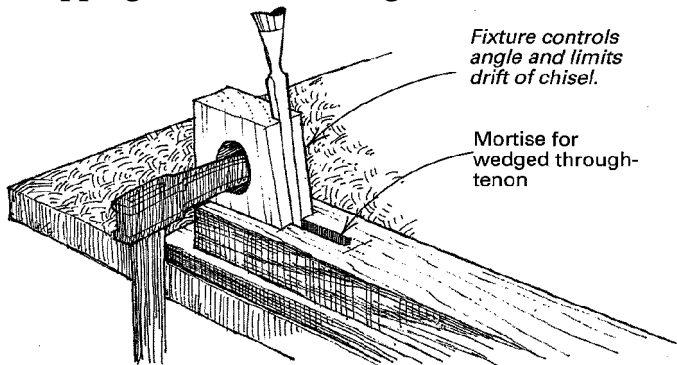

A design for sofas and chairs our shop recently built specified that the arms be attached to the front legs by wedged through-tenons. I solved the problem of cutting a mortise with consistently tapered ends for the wedges by first wasting most of the mortise with a plunge router. Then I chopped out the ends of the mortise with a sharp chisel guided by this fixture (above) that controlled the chisel angle and its lateral drift. —Joseph M. Wilson, Picou, N.S., Canada

End-chamfering fixture for dowels

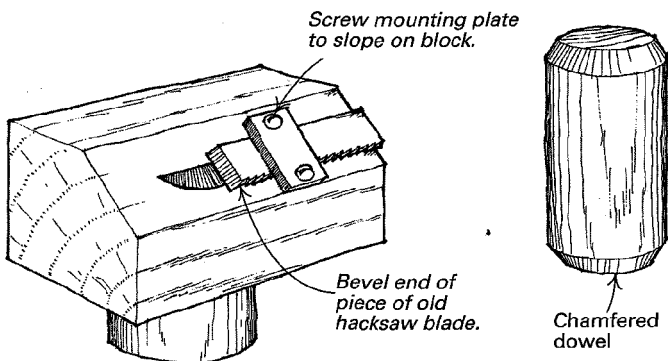

To cut a chamfer on the end of a wooden pin or dowel, I made this fixture using an old hacksaw blade. To make the cutter, drill a half-blind hole into a wooden block. Then bevel the top of the block 45° to reveal a slight opening at the bottom of the hole that you've drilled. Break off a short length of a hacksaw blade, and bevel an end on a grinder and sharpening stones. Fix the

blade on the block's slope with a mounting plate, as shown in the drawing below left. The depth of cut is determined by the amount the blade overlaps the opening.

To use the cutter, simply insert a dowel into the hole and turn. If you want a really smooth cut, make a first cut with a cardboard spacer in the bottom of the hole. Then remove the spacer, and make the final cut. —Osamu Otake, Nagano, Japan

Square-headed tenon pins

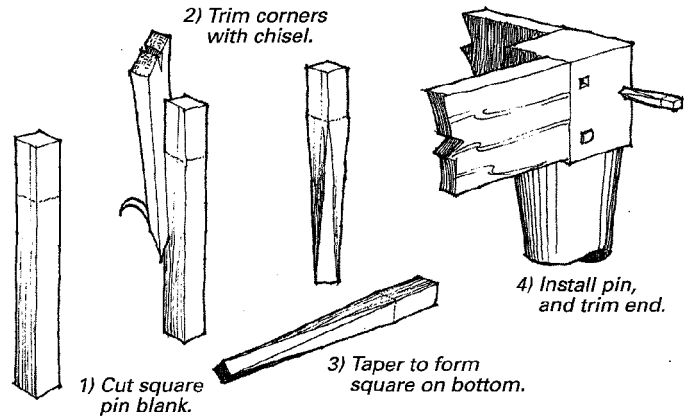

A mortise-and-tenon frame isn't complete unless the tenons are pinned. Square-headed pins strengthen the joint and add visual interest, and they also feel right. Here's how I do it:

With the rails clamped tightly in the frame, I drill the pin holes through the mortise cheeks and the tenon, all equal depth with a 1/4-in. bit. If you want to emphasize the square corners of the pin, square up each pin hole at the top with a 1/4-in. chisel. To cut the pin blanks, I use the drill bit as a gauge and set the saw fence exactly 1/4 in. from the blade. I raise the blade just over 1/4 in., and rip several lengths of 1/4-in.-sq. pin stock from some hardwood such as oak. I cut the pin blanks to length by adding 1/2 in. to the depth of the pin hole, and draw a pencil line on the pin blanks to show the hole depth.

Now I taper the pin by shaving each corner with a sharp chisel. I start at the depth mark and pare progressively deeper as I push to the bottom of the pin, taking two or three slices per corner. When the taper is right, the bottom of the pin will have a square cross section that's smaller than the top of the pin blank. Next I put a dab of glue in the hole and pound each pin into place, taking care to align the corners of the pin with the square hole. The pin should have just the right amount of resistance as it bottoms out. When I trim, I leave about 1/16 in. of the pin proud, which makes a nicely rounded head when sanded.

—Larry Joseph, Alva, Okla.

Production glue pot

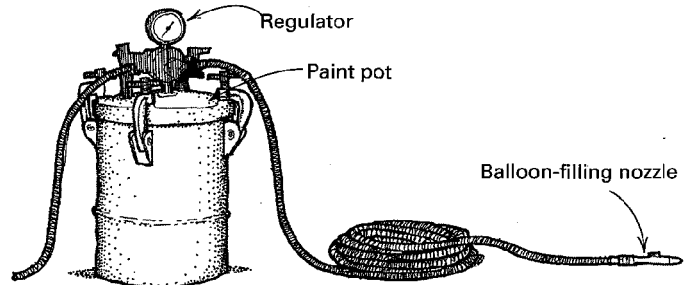

In our speaker-making plant, we use lots of polyvinyl-based glue. It all starts in a Binks Paint Pot, goes through a regular 3/8-in. air hose and exits through a helium balloon-filling nozzle (available at welding supply stores). To prevent rust in the

paint pot, we sprayed some cold galvanizing compound on the inside of the top and always use a paint-pot liner.

—Chuck Waugh, Boring, Ore.

Drill-press mortising

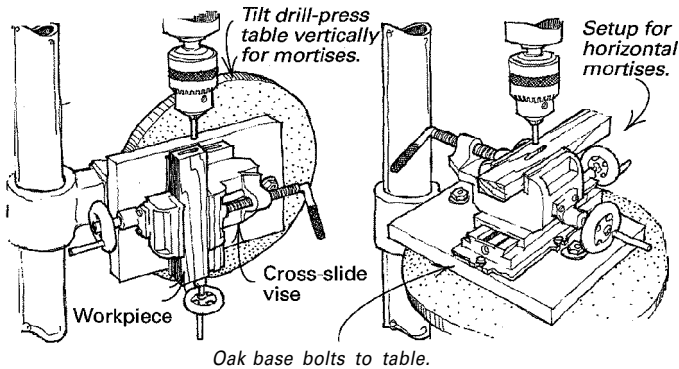

Inspired by Ken Picou's loose-tenon joinery and Ross Day's shop-built mortiser (*FWW* #98, p. 46), I turned my drill press into a mortiser by adapting a cross-slide vise.

I lag-bolted the vise securely to a heavy piece of oak, which, in turn, I bolted to the drill-press table. My drill press, a popular import model, has a round table that can pivot. This feature allows me to position the cross-slide vise for either horizontal or vertical mortises.

I set the drill press at its highest speed (3,200 rpm) to cut the mortise quickly and cleanly.

—John F. Clemens, St. Louis, Mo.

Plaster of paris fastening system

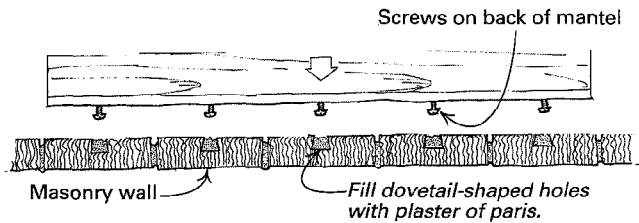

This technique for mounting fireplace mantels to brick walls adapts to many other applications where strong but hidden fastening is needed. Screw several large sheet-metal screws into the underside of the finished piece to be attached. For each screw, drill a mating hole into the brick or stone. Enlarge the bottom of the holes (to form a dovetail shape) by redrilling several times at an angle. Fill the hole with wet plaster of paris, and quickly place the screws into it. The soft plaster will harden in just a few minutes.

—Gene Carson, Blackburg, Va.

Wedge-tightened stop block

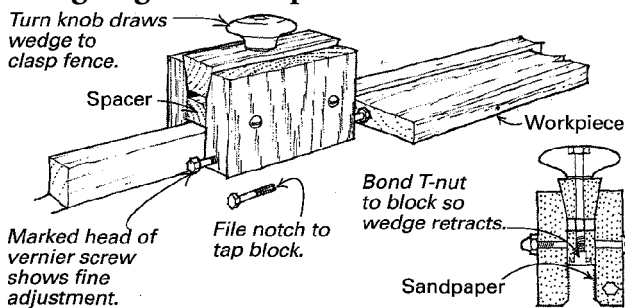

This easy-to-set radial-arm-saw stop block incorporates two useful features: a wedge-tightening mechanism and a vernier screw for fine adjustment. I use the fine adjustment to correct tri-

al cuts. The stop's chamfered inside edges allow for sawdust clearance, and the sandpaper provides grip on either the left or right fence.

—Francis Chan, Nassau Bay, Texas

Rubber-band clamps

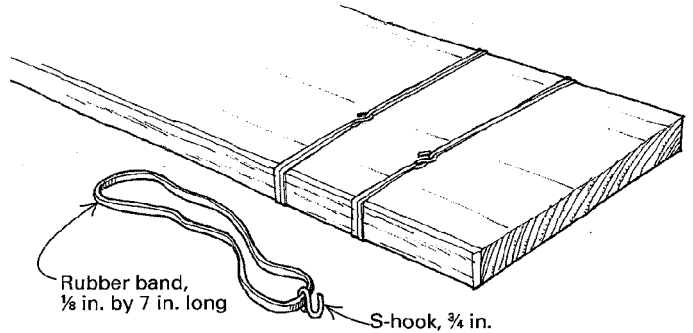

A woodworking friend of mine once grumbled that he wished he were in Heaven because "In Heaven they have enough clamps." This common lament came back to me recently as I attempted to glue edging strips to plywood shelves with too few clamps. So I decided to try to make some clamps using rubber bands and hooks.

A trip to the stationery store revealed that rubber bands come in many different sizes and styles. I bought a box of the largest they had, which were about 1/8 in. wide and 7 in. long. A trip to the hardware store yielded a supply of 3/4-in., open S-hooks. I attached a hook to each rubber band by bending the hook closed using a pair of pliers. The other end of the hook stays open to clasp the other end of the same rubber band.

—John B. Moon, Mount Vernon, Wash.

Rounding over the edges of small boards

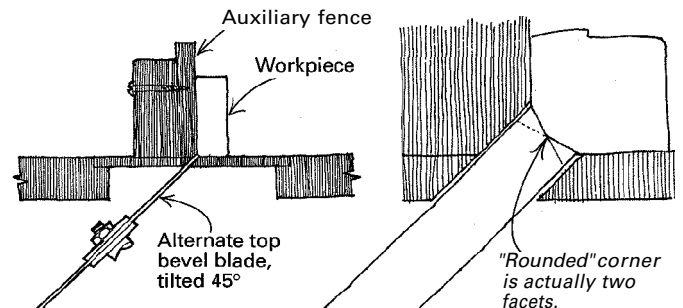

Because I couldn't find an appropriate router bit for putting a tiny radius on the edges of small boards, I came up with this method using a tablesaw, which cuts a corner that's less than 1/8 in. on a wooden workpiece. First install a standard alternate top bevel (ATB) sawblade in your tablesaw. ATB blades are fitted with beveled teeth and have no square raker teeth. Set the blade angle to 45°, and use a machinable wooden fence and table insert. Adjust the fence so that the blade's centerline will travel exactly into the square edge of your workpiece. Some eyeballing and trial and error may be required to position the fence. Adjust the radius up to about 1/8 in. by cranking the blade into the edge.

What you are actually getting are two facets along the corner. On this small a scale, the edge looks and feels virtually round, especially if you sand lightly.

—Per Madsen, San Francisco, Calif.

Methods of Work buys readers' tips, jigs and tricks. Send details, sketches (we'll redraw them) and photos to *Methods*, Fine Woodworking, PO Box 5506, Newtown, Conn. 06470-5506. We'll return only those contributions that include an SASE.

Rail-clamping featherboard

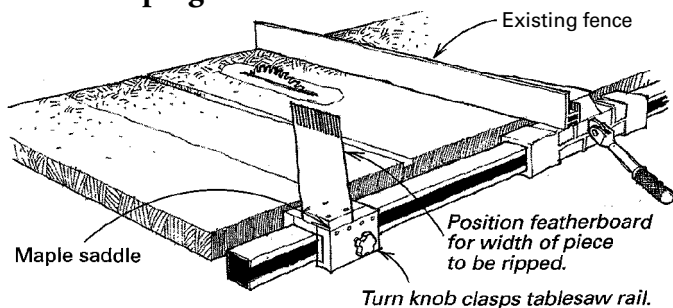

I regularly use a featherboard when ripping stock in my shop. However, it is often difficult to clamp a traditional loose featherboard to the table quickly and securely. To eliminate this problem, I made a hard maple saddle that rides on my rectangular fence rail and screwed a featherboard to the top of the saddle at about 45°. I salvaged the locking knob from an old compressor regulator, but similar knobs are available from The Woodworkers' Store (21801 Industrial Blvd., Rogers, Minn. 55374-9514). To prevent damage to the fence rail, I inset a wooden strip under the knob stud, which is counterbored to accept two loosely fitting screws. I can quickly lock the featherboard assembly in any position along the fence rail and, with a quick twist of the knob, remove the whole assembly to make way for crosscutting. By varying the saddle design, this method could be used with any fence rail, such as the tubular type. —Bert B. Boyd, Salem, Va.

Quick tip: Grind one of the spurs on your lathe's live center to a point. This will allow you to reposition the work to exactly the same position if you have to remove it
—C. A. Robson, Ont, Canada

Sharpening bandsaw blades

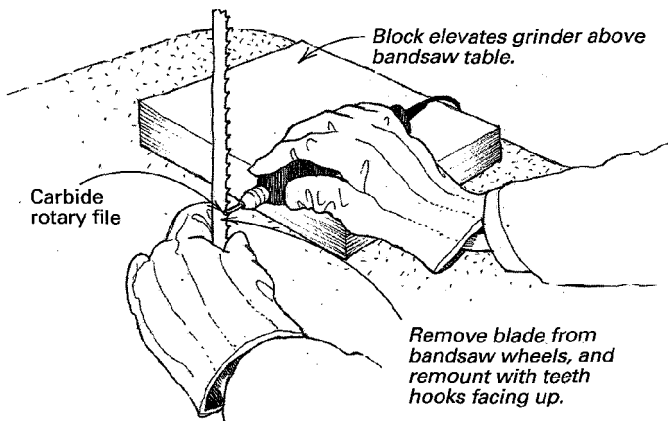

I use this simple procedure for accurately and quickly re-sharpening bandsaw blades. Compared with the commercial rate of \$16, it is certainly worth the 20 minutes. Perhaps more important, it is liberating to know I'll never run out of bandsaw blades over a busy weekend.

The first step is to unplug the machine. Take the blade off, turn it inside out and replace it on the wheels with the hooks up. Then, using a carbide rotary file mounted in a Dremel grinder, grind the hook and top of each tooth. Hold the grinder straight to the front, as shown in the sketch. No odd angles are needed. Support the grinder on a book or scrap of wood. Set the grinder to just below maximum rpm.

The technique works well on the 4-teeth-per-inch, 3/4-in. blades I commonly use, but it gets a bit tedious on smaller blades with finer teeth. —John Grew-Sheridan, San Francisco, Calif.

Portable flood lights revisited

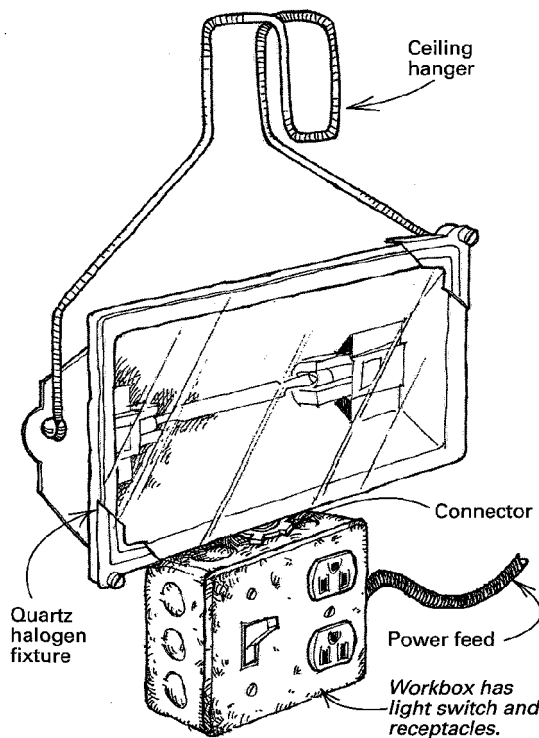

Here's how I redesigned Lester Lavy's portable flood lights (FWW#101, p. 16) to sidestep any potential problems from the heat these lamps generate. I placed the connection box below the lamp and added a long, heavy steel-wire hook to hang the unit about 10 to 12 in. from the ceiling. This arrangement reduces the chances of melting the power cord and minimizes heat buildup in the circuit box. I also chose to use a larger 4-in. electrical box so that I could switch the light and power outlet on and off.
—Jim Allen, Atlanta, Ga.

Jointing on the tablesaw

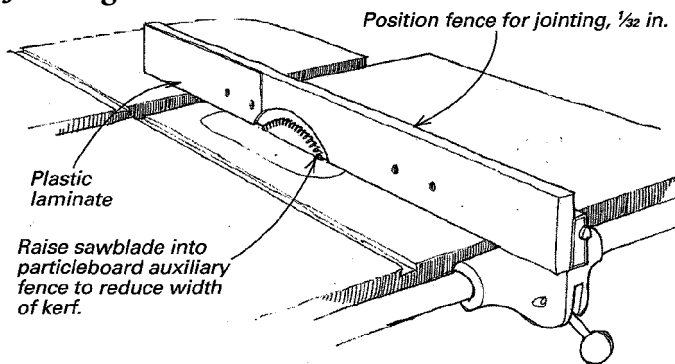

I needed to joint the edge of a 1/2-in.-thick tabletop laminated up from two pieces of 3/4-in. particleboard. The piece was too long and unwieldy for my jointer, and I didn't want to dull my knives on the particleboard. So I used this technique to joint the workpiece on the tablesaw.

Make an auxiliary fence the same height as your saw's rip fence. Contact cement a strip of 1/2-in.-thick plastic laminate to the face of the auxiliary fence. Screw the auxiliary fence to the rip fence, lower the blade and adjust the fence location until the plastic laminate is flush with the edge of the blade. Turn on the saw, and slowly raise the blade, cutting a kerf into the auxiliary fence.

Place the piece to be jointed flat on the saw table, hold the

workpiece against the fence and push it through the blade. The far end of the fence will act as an outfeed table. Each pass will remove about 1/32 in. of material, the same thickness as the laminate.

—Gary P. Westmoreland, Apple Valley, Calif.

270° cabinet doors

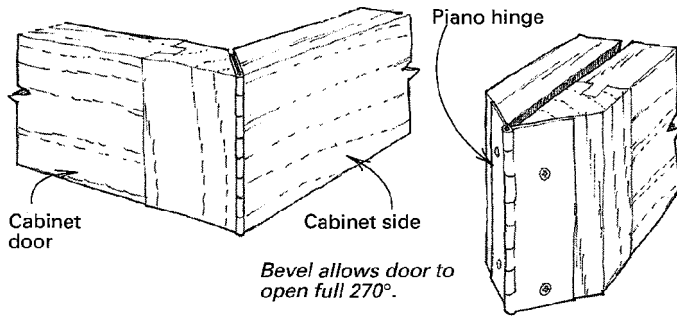

For freestanding cabinets, it is often useful for their doors to open 270° so that they will lay flat against the side of the cabinet. However, most common ways of attaching doors allow the doors to open only to 90° or 180°, even when 270° hinges are used. To enable the full 270°, bevel both the door and the side of the cabinet at 45°. Attach the hinges on the bevel as shown.

—Jafar Syed Hasan, Tawas City, Mich.

Quick tip: In the article "How to Build a Barrister's Bookcase" (FWW#96, p. 51) the author mentions a problem of drilling hardened steel. Drilling spring steel without shattering it can be easily done if the steel is first softened. Heat the place where the hole is

to be drilled with a propane torch to a bright red glow and allow it to cool slowly by gradually withdrawing the heat. Take care to localize the softening only to the area to be drilled.

—Howard C. Lawrence, Cherry Hill, N.J.

Japanese textile-tape hinge

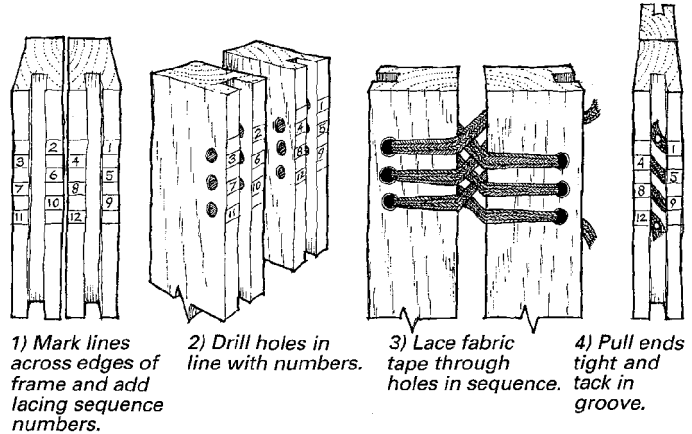

I recently had the chance to repair a turn-of-the-century Japanese *shoji* screen and was intrigued by the laced textile-tape hinges, which were different from anything I remember seeing. To reproduce the hinge, start by picking the lacing material. Twill tape available at sewing shops is nearly identical to the tape I found on the original screen. But shoestrings, rawhide or any flat flexible cordage would work as well. Lay the grooved panel frame rails side by side, and mark seven evenly spaced

lines across the edge of both pieces. The distance between these lines should be the width of the cloth tape. Mark the lacing sequence numbers on the edge of the rails, and drill holes as shown in the sketch. Hole pairs 1-2 are in line with each other, as are 3-4, 5-6 and so on. To complete the hinge, lace the textile tape through the holes in the sequence marked. Pull the lacing tight, and tack the ends to secure them.

A big advantage of this hinge is that it allows full movement in either direction, which is not possible with a regular pinned hinge. Another clever feature is the hiding of the diagonal lace offset within the grooves, making the laces parallel on the outside. On the original screen, the lace holes were rectangular and bushed with rectangular eyelets, but round holes work just fine. Besides *shoji* screens, the hinges would also work in furniture where a full rotation is needed, such as for a room divider or shutters. —Erwin O. Deimel, New Hartford, N.Y.

Bar-clamp stain protectors

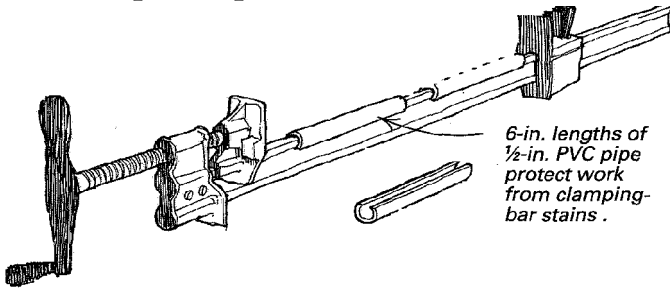

6-in. lengths of 1/2-in. PVC pipe protect work from clamping-bar stains.

In the process of collecting materials to glue up a tabletop, I discovered that I was out of waxed paper. I had always put waxed

paper between my work and the bar clamps to prevent the black stains that invariably result when aliphatic-resin glue, iron and wood combine for any length of time.

In looking around for a suitable alternative, I remembered a short length of 1/2-in. schedule 40 PVC pipe I had. I cut the pipe lengthwise with my bandsaw to reveal a slot just under 1/2-in. Then I cut the pipe into convenient 6-in. segments and snapped the segments over the iron bars of the clamps. If the slot is the right width, the segments will grip the bars and stay in place even when the clamps are turned over or hung up to store.

—Thornton Traise, Omaha, Neb.

Saw vise

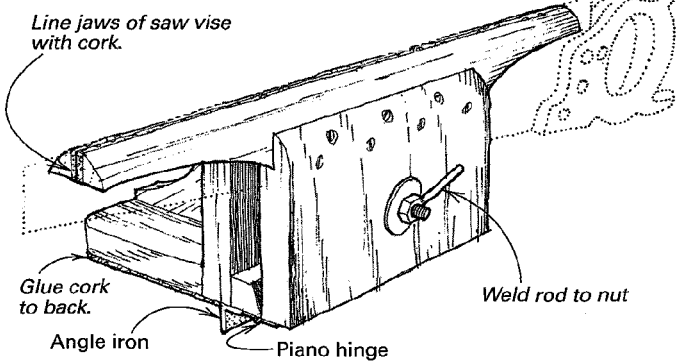

When my partner brought in a saw vise he had built, I was so impressed by its utility and appearance I asked to copy it.

To build the vise, first select a strong hardwood such as birch, 1 1/4 in. thick for the jaws and at least 1 in. thick for the legs and

base. Laminate a layer of 1/4-in. cork to the jaw faces and to the base of the vise to provide a firm grip on the sawblade and to reduce chatter. Install a 1/2-in. carriage bolt through the jaws to tighten them. To provide extra tightening leverage, weld a 3-in. length of steel rod to one face of the nut as shown. Finish your vise with a coat of varnish. —*Jerome A. Jahnke, Milwaukee, Wis.*

Tablesaw light

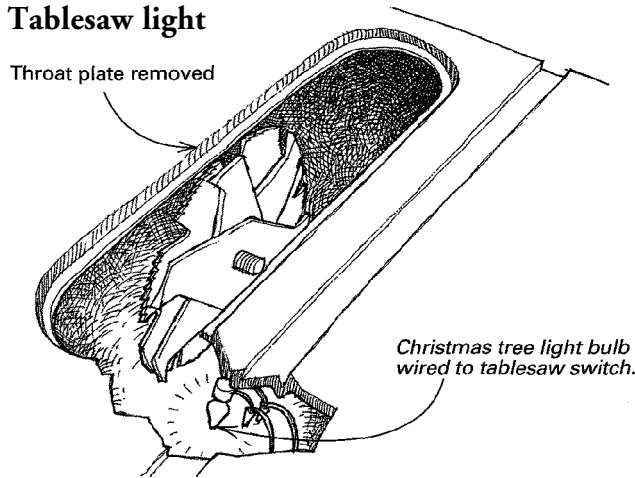

For many years, my tablesaw sat outside. I didn't realize how much I used the natural light flooding through the frame of the saw until I moved the saw into my newly completed garage and enclosed the sides to contain the sawdust. To replace the natural light I lost, I installed a clear Christmas tree light bulb inside the saw near the right front corner of the blade insert open-

ing. Then I wired the light directly to the saw switch.

I like to sight down the surface of the blade with one eye to align the blade with the pencil mark on the wood. That was impossible to do when the void below the top was in darkness. By unplugging the motor cord from the switch box and then turning the switch back on, I have all the light I need for changing the blade. —*Donald Switzer, San Diego, Calif.*

Cutting pocket holes on a router table

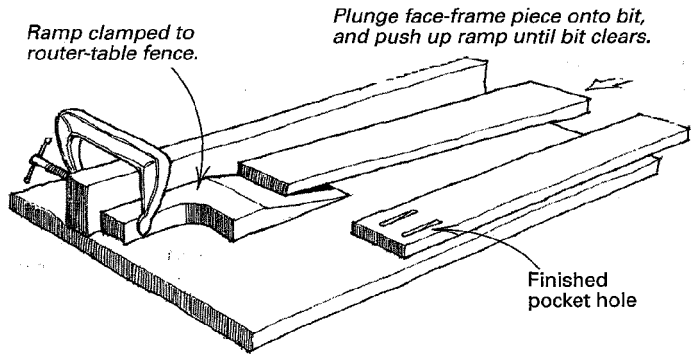

Not too long ago, I went down to the tool store on a wishing trip. I saw a pocket cutter, which I really don't need for the five or six screw pockets that I cut in a year. But something pushed my Rube Goldberg button, and I rushed back to the shop to build a complicated pocket-cutting contraption that used an old router suspended from a shaft like a pendulum. Well, after I cut pockets in all my scrap lumber, I began to wonder "Now what do I do with the machine—put it on a shelf to collect dust?"

About this time, the Goldberg fever left me, and I remembered something my dad told me: "Maybe you don't need another machine. Just figure out how to do the job with something you already have." So after some thought, I came up with a markedly simpler method using a ramp and my router table. I simply position the work and the bit depth where I want the pocket to start. Then, keeping my hands well back from where the bit is, I plunge the piece onto the table and push it up the ramp until the bit quits cutting.

—Vernon Todd, Springfield, Mo.

Shop-built panel saw

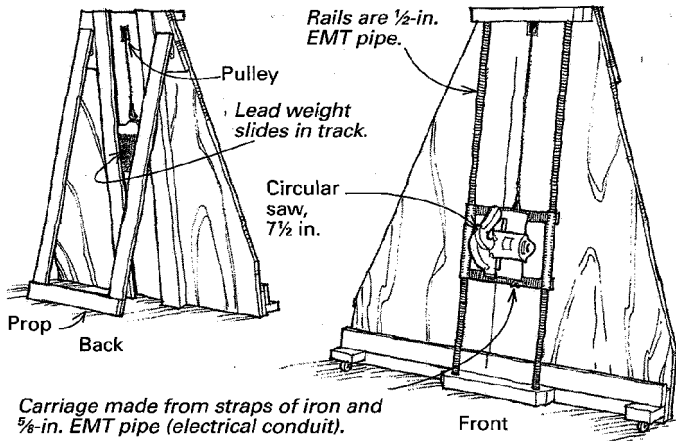

After wrestling 4x8 plywood panels around my shop for 45 years, I decided to build a panel saw. The design I used is sim-

ple and inexpensive. The fixture's components and construction details are shown in the sketch below. The only tricky part is the carriage.

For the carriage sliders, split two pieces of $\frac{5}{8}$ -in. EMT pipe (electrical conduit) end to end. Spread the cut, or squeeze until the sliders have a nice sliding fit on the $\frac{1}{2}$ -in. rails. Bend the ends of the crosspieces up to conform to the radius of the tubing. With the sliders and crosspieces clamped in place on the rails, tack-weld the pieces together. Check the carriage to make sure it is square and slides smoothly. If all is well, remove the carriage, and braze all four corners. Now position your saw on the carriage, drill mounting holes and fasten the saw to the carriage. To keep the carriage running smoothly, keep a little paraffin or light grease on the rails.

I made the saw counterbalance weight by melting down some lead and pouring it into a rectangular mold. The counterbalance should be slightly heavier than the saw so that the saw will stay parked at the top of the rails.

—William Skinner, Everett, Wash.

Quick tip: Even if you use a file card, occasionally you will encounter stubborn bits of waste lodged in the teeth of your file. Run the head of a 6d finishing nail along each tooth groove. Because the metal in the nail is softer than that of the file, the head will conform to the tooth configuration and remove anything that the file card missed.

—Mario Rodriguez, Brooklyn, N.Y.

Methods of Work buys readers' tips, jigs and tricks. Send details, sketches (we'll redraw them) and photos to *Methods*, Fine Woodworking, PO Box 5506, Newtown, Conn. 06470-5506. We'll return only those contributions that include an SASE.

Jointing boards with the router

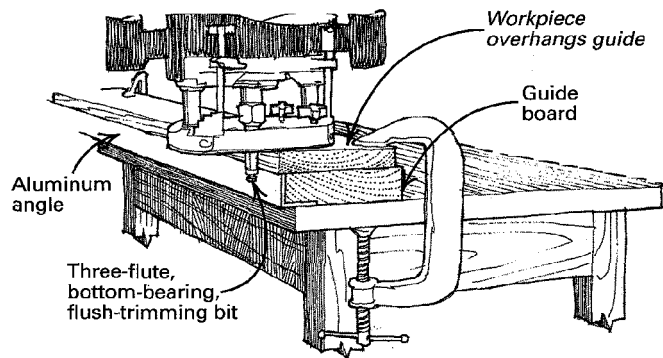

If you don't have a jointer, this easy-to-use jig lets you joint boards with a router. The method depends on a simple aluminum-angle-edged guide board and a commercial-grade flush-trimming bit. I use the Bosch #85602M bottom bearing, flush-trimming bit, which features three cutting flutes, a replaceable bearing and a 1½-in. cutting length.

To construct the jig, rabbet the guide board to receive the aluminum angle. Attach the angle to the guide board with countersunk screws every 6 in. or so. Now clamp the workpiece over the guide board so that it overhangs the aluminum bearing surface by ⅛ in. or less. I like to use deep-throat Vise-Grip clamps to clamp the workpiece to the guide board, but C-clamps will work fine. If the workpiece is badly bowed, take two cuts, or rip the board on the tablesaw first. This concept has worked so well I made a smaller version for jointing the ends of crosscut boards. For this operation, it's important to double-check your depth setting to make sure the bit clears the angle. Also, take light cuts (less than ⅛ in.) to avoid burning the workpiece.

—Andrew A. Westerhaus, Burnsvitte, Minn.

Mortise shaving fixture

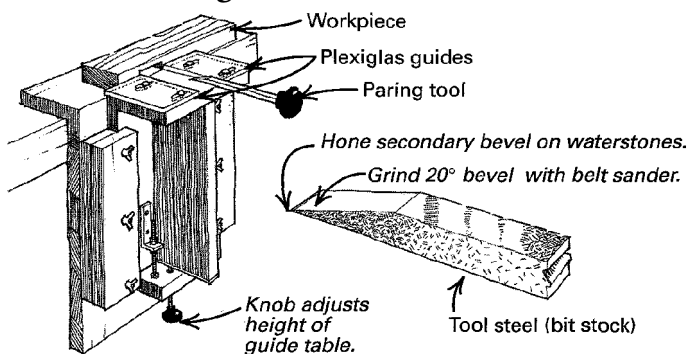

With this fixture, you can produce perfectly sized mortises with glass-smooth walls and ends. The process is much slower than using a hollow-chisel mortiser, but the results are superior. Use it whenever a joint will be highly visible.

The fixture consists of two parallel tables, one that holds the workpiece and another that guides the paring tool. An adjustment mechanism at the bottom of the fixture raises or lowers the guide table into position where it then locks in place with wing-nut tightened blocks.

The secret to making perfect mortises is in the paring tool. It must have a long primary bevel, be sharp and perfectly flat, perhaps even slightly concave, on the back. I make my tools from square-profiled tool-steel bit stock, which is available from MSC Industrial Supply Co. (151 Sunnyside Blvd., Plainview, N.Y. 11803; 800-645-7270) or any well-stocked industrial supply house. The steel comes in several sizes, but I use the ⅝-in.-sq. size the most. Attach a handle to an 8-in. piece of steel, and then

grind the steel at a steep bevel, somewhere between 15° and 20°, on the belt sander. This works better than a high-speed abrasive wheel because the belt cuts fast but doesn't overheat the edge. Now hone a secondary bevel using a honing guide and a progression of Japanese waterstones. Don't flatten the back of the steel as you do when sharpening a regular chisel. The paring and corner cleanup go better if you just leave the back of the tool alone.

To use the fixture, lay out the mortise with a sharp awl. Hog out most of the waste with a Forstner bit in the drill press. Leave the mortise layout line. If needed, trim out large waste areas of wood with a regular chisel. Now place the workpiece in the fixture, and clamp it in place. Adjust the height of the guide table to the mortise line, and lock the Plexiglas end guides at the ends of the mortise. Keeping the paring tool flat on the guide table, pare the sides of the mortise. Finally, turn the tool 90° to trim the end of the mortise.

—Bill Webster, Chillicothe, Ill.

Window-shade assembly-table protector

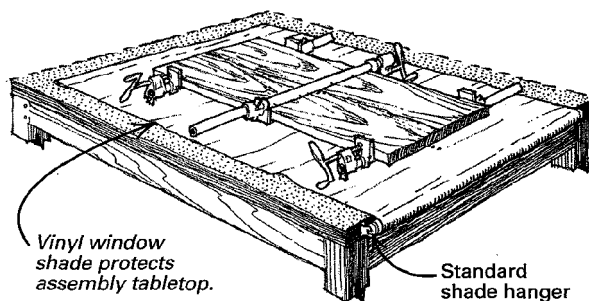

Here's a simple solution to the problem of glue squeeze-out dripping onto your assembly table when clamping. Attach a common vinyl window shade to the end of the table with standard hanger brackets. Before glue-up, pull the shade over the bench. Any glue squeeze-out will fall on the shade where it will harden. When you roll up the shade, most of the glue will fall off where it can be swept up. The shade stores out of the way ready for the next project. Vinyl shades are available in a variety of widths to fit your bench and are quite durable, especially the heavier shades made for darkening rooms.

—Fran Luta, Brownstown, Pa.

Sanding block

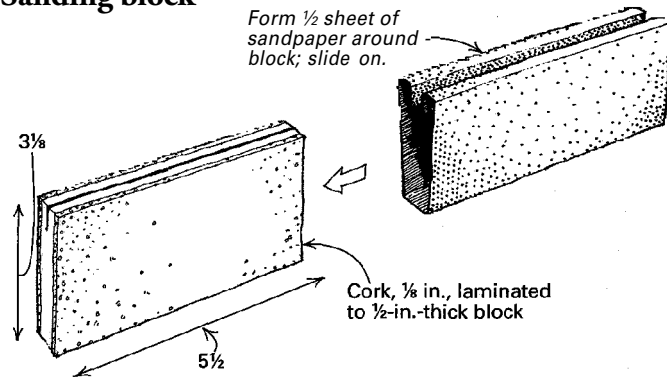

These sanding blocks are sized to take a half sheet of paper. The slot in the block will hold the paper in place without glue or wedges. Cut the block to the dimensions shown in the drawing above, and add a ⅜-in.-deep sawkerf along one edge. A ½-in.-thick block with ⅛-in. cork laminated to each side makes a good sanding block.

To install the sandpaper, slide one end of the paper into the kerf; bend the paper tightly around the block to form the corners. Remove and insert the other end of the paper into the kerf,

and bend it the other direction around the first couple of corners. Hold the two ends of the paper together, and slide it onto the block as shown. Friction will then hold the paper in the slot.

—Martin Harrison, San Francisco, Calif.

Boring jig with cam-lever hold-down

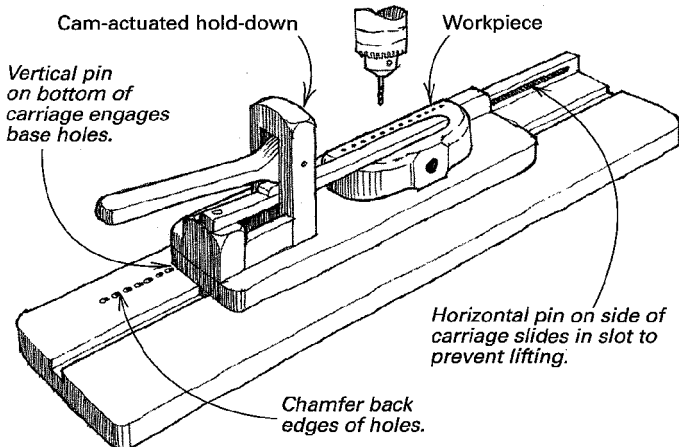

When I began making production runs requiring 12 evenly spaced holes in 50 blocks, I designed this jig, which incorporates several features, including a cam-activated hold-down and a sliding pin to prevent the fixture from lifting up. The jig consists of two main parts: the carriage and the bed. The carriage carries the block to be drilled and the cam-activated hold-down. Embedded in the bottom of the carriage is a $\frac{1}{8}$ -in. pin that en-

gages carefully drilled holes in the bed. Each hole is slightly filed on the back edge to provide a ramp that the pin can ride down into the hole.

Because the drill press tends to lift the carriage when the bit is backed out of the hole, I added a pin to the back edge of the carriage and routed a slot in the side of the bed for the pin. This keeps the carriage snug to the bed while allowing the other end of the jig to be lifted slightly to advance to the next hole.

—Daniel R. Maxon, Essex Junction, Vt.

Drawer dividers from plastic laminate

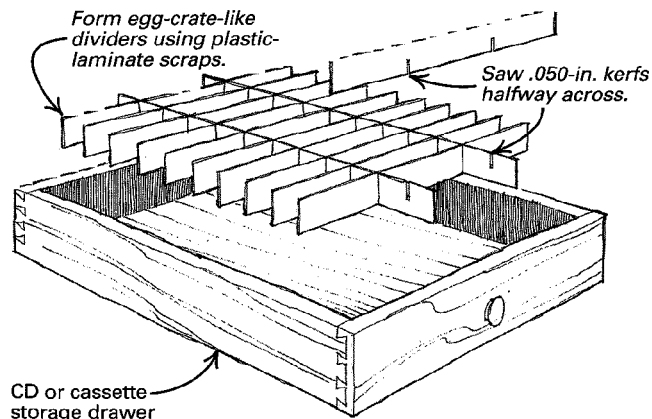

My one-man shop generates a lot of plastic-laminate scraps, which I use to make egg-crate drawer dividers for CDs and audio and video cassettes. To make the dividers, rip the laminate

scrap into 2-in. strips. Then stack the strips, and cut narrow slots halfway through. You'll need a tablesaw blade with a .050-in. kerf for cutting these egg-crate slots. I bought the blade I use from Blaisdell Saw (4040 S.E. Division, Portland, Ore. 97202; 503-235-2260) for about \$31. Use a pair of blade stabilizers when running the thin blade.
—Tom Marks, Portland, Ore.

Square-headed tenon pins

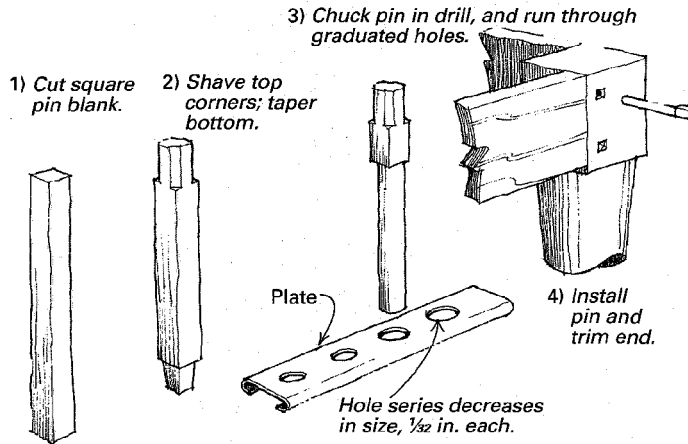

A customer's design called for mortise-and-tenon construction with the tenons pinned through the mortise cheeks. Rather than flush-cut dowels, I decided to use round pins with square heads. Here's how I did it.

After drilling $\frac{1}{4}$ -in. holes through the cheeks, four chops with a chisel gave a $\frac{1}{4}$ -in.-sq. recess on the surface. Making the pins

is a little more work. First cut pin blanks slightly larger than $\frac{1}{4}$ in. sq. Trim the corners of the top $\frac{1}{2}$ in. of the blank to make a short octagonal section, and put a stub on the other end. Chuck the octagonal section of the pin in your drill, and put the pin through a series of holes drilled in a piece of sheet metal to round the lower portion. I used an old discarded drawer slide. The series of holes diminish in diameter; in my case, I used $\frac{5}{16}$ in., $\frac{9}{32}$ in., $\frac{1}{4}$ in. and $\frac{7}{32}$ in. You can keep the length of the square head consistent by performing the operation through a wooden washer, which acts as a stop between the metal and the drill chuck.

Glue the pin into the furniture in the regular way. The $\frac{1}{32}$ in. difference between the pin and the hole allows the glue to swell while the pin's head is rotated to align with the square socket. You can saw the square head flush with the surface, but I opted to carve a little hip roof on the pin head and left it proud.

—Joseph M. Wilson, Pictou, N.S., Canada

Quick tip: To prevent chipout on expensive veneered plywood, first set the sawblade just proud of the table. With the saw turned off, slide the workpiece against the rip fence, pushing down so that it rolls the blade beneath it. Then flip the piece over, clamp on a straightedge, and score the veneer with a knife along the dotted line marked by the tips of the rolling blade.

—Larry Preuss, M.D., Ann Arbor, Mich.

Disassembling epoxied joints

For some time, I have been involved in the restoration of antique furniture where I often encounter a piece that has been "repaired" using epoxy. To disassemble these epoxied joints, I heat the joint with a hot-air gun, the kind used for paint strip-

ping. By carefully directing the hot air evenly to the joint so that the wood gets hot all the way through, the glue will eventually break down. Don't get the gun too close, or you will burn the surface of the piece. By applying steady tension to the joint during the heating process, the joint will slowly move and eventually come apart. Good ventilation and appropriate breathing precautions are required, as well as considerable patience.

—Richard Goodall, Salmon Arm, B. C., Canada

Auto-jack bench vise

Weld bearing plate to auto jack.

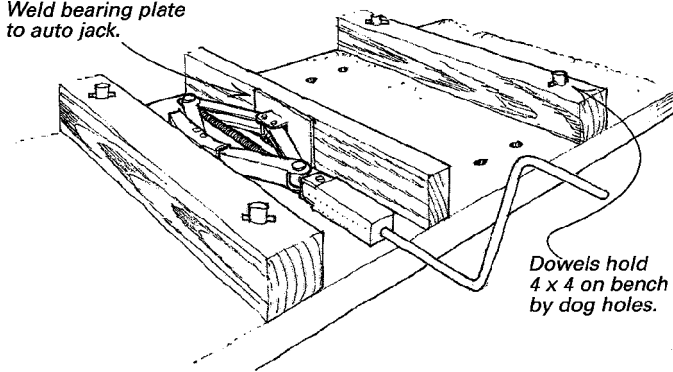

Dowels hold 4 x 4 on bench by dog holes.

I removed the permanently mounted vise from my workbench to free the entire perimeter of the bench of clamping obstructions. I then added back the removable vise shown in the sketch, which is based on a salvaged auto jack. I sawed off the swiveling saddle on the top of the jack and welded in its place a chunk of 1/4-in.-thick steel plate. A 2x4 screwed to the steel plate

makes the movable jaw of the vise. At the other end, the fixed jaw is simply a 4x4 held in place by 1-in. dowels that drop into dog holes in the bench. I also attached a crank handle to make tightening the vise a one-handed operation.

Although the arrangement isn't perfect, it clamps with a force beyond anything normally required in woodworking, removes from the bench easily and cost less than \$10.

—Tim Anderson, Chippewa Falls, Wis.

Clamping jig for door frames

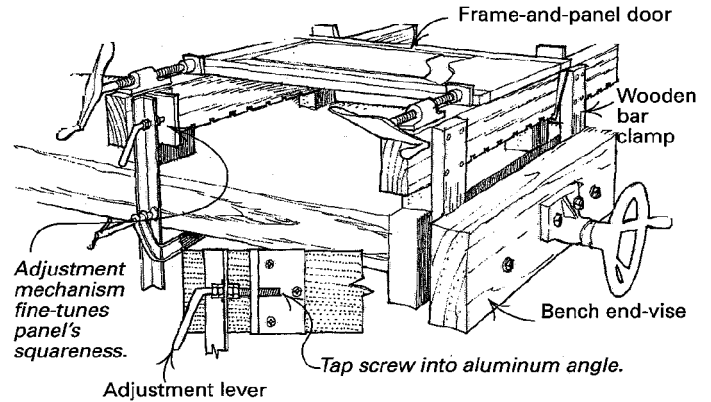

Adjustment mechanism fine-tunes panel's squareness.

Tap screw into aluminum angle.

Adjustment lever

I designed this jig specifically to glue up small paneled doors. With it, you can adjust away any tendencies of the door to go out of square as it is being clamped up. The jig consists of two clamping bars. The first is fixed in the vise at the end of the workbench. The second is attached to a length of angle iron that

is clamped to the bench. The second clamp incorporates a threaded adjustment mechanism, which moves the clamping bar in or out slightly. This allows you to change the position of the second clamp until the diagonals across the door measure exactly the same. —*Leo Moisan, Laurier Station, Que., Canada*

Strap-clamp blocks

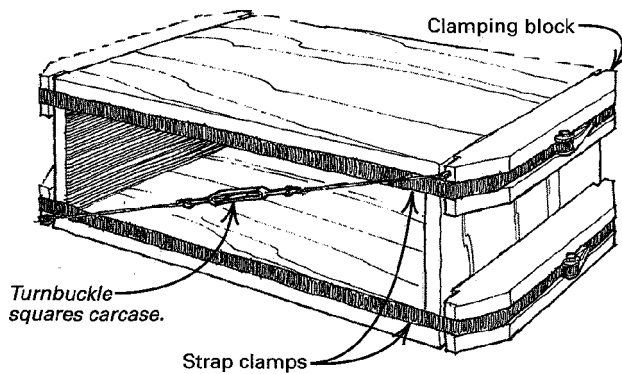

Over the years, I had struggled to assemble case work with pipe clamps, assuming there was no better way. The clamps were heavy, awkward, in the way, wood-marring and hard to adjust for even pressure. Sometimes my lightly tightened clamps would fall off while I was making final adjustments.

So I started playing with strap clamps with better results. I ended up making clamping blocks, like those shown in the sketch above, to use with them. Then it dawned on me to put screw eyes in the ends of the clamping blocks and tie the opposing

corners together with a turnbuckle. This addition made pulling the piece into square incredibly easy.

—*George Viveiros, North Kingstown, R.I.*

Bench clamping with hand screws

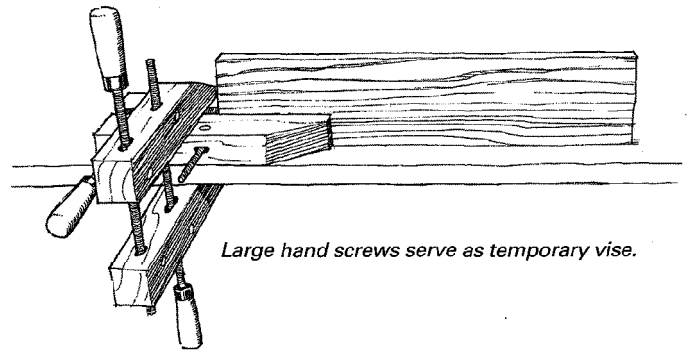

The workbench I am building doesn't have a vise yet. As an interim solution, I use two large hand screws. I lay the first clamp horizontally on the bench to hold the work. Then I clamp the first clamp to the bench lip with the second clamp, as shown in the sketch above. This arrangement has the advantage of being cheap, moveable, strong and versatile.

—*Thomas Grace, Binghamton, N.Y.*

Methods of Work buys readers' tips, jigs and tricks. Send details, sketches (we'll redraw them) and photos to *Methods*, Fine Woodworking PO Box 5506, Newtown, Conn. 06470-5506. We'll return only those contributions that include an SASE.

Transporting plywood in a small-bed pickup

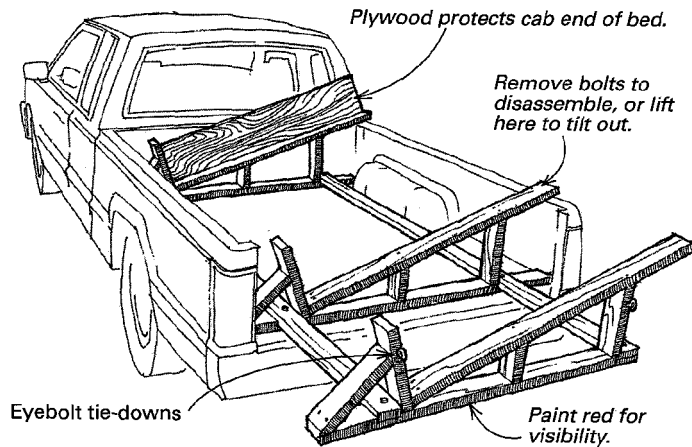

This rack solves the problem of transporting 4x8 sheet goods in a small-bed pickup. To make the rack, build three truss-like supports that slip into notches in the 2x4 runners. Fasten with a single bolt and T-nut per joint. Extend the tall side of the rack about 2 in. higher than the side of the truck to provide easy access from the side. To keep the sheet goods from banging the front of the bed, attach a plywood panel to the front support. Paint the back support red for visibility, and install two eyebolts to serve as tie-downs. When the rack is not needed, disassemble it either by removing six bolts or by lifting up on the long ends to tilt it out of the bed.
—Keith Woodworth, Houston, Texas

Recessed wheels for toy cars

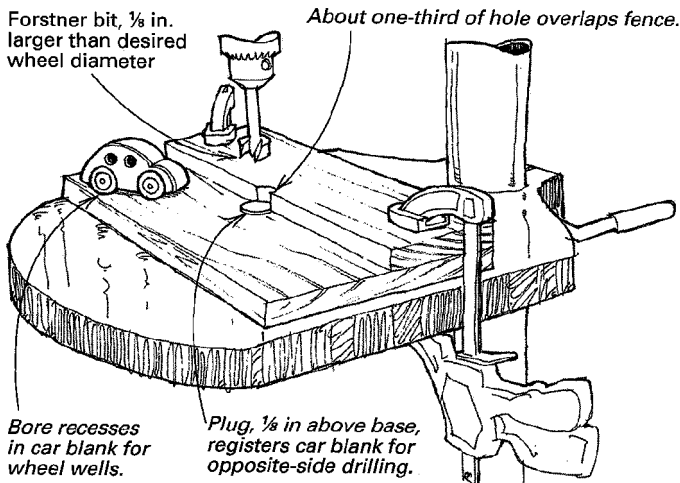

Here is a simple method for recessing the wheels into the bodies of toy wooden cars. First make a jig by face-gluing two 3/4-in. boards, one-half as wide as the other, as shown in the sketch above. With a Forstner bit 1/8 in. larger than the wheel you are using, bore a hole into the jig. About one-third of the hole should overlap the fence. Turn or whittle a wooden plug that fits into the hole. Cut off the plug so that it protrudes 1/8 in. above the wide baseboard.

Clamp the jig to the drill press with the plug centered under the bit. Remove the plug. Place a car blank on the jig, and bore front and rear recesses into the car body about 1/4 in. deep. Continue with all the car blanks until you've bored all the wheel wells on one side of the cars. Insert the plug. Turn over the car bodies, and place the car onto the jig so the plug registers the car right under the bit. Bore recesses into the other side.

Finally, remove the plug, and replace the Forstner bit with a

regular bit, 1/64 in. larger than the dowel being used for the wheel axle. The regular bit will find the center of the hole made by the Forstner bit if you bring the press down slowly, and you allow the stock to move right or left. When the bit begins to bite, hold the stock firmly.
—Clyde Pophal, Madison, Wis.

Overhead plug-ins

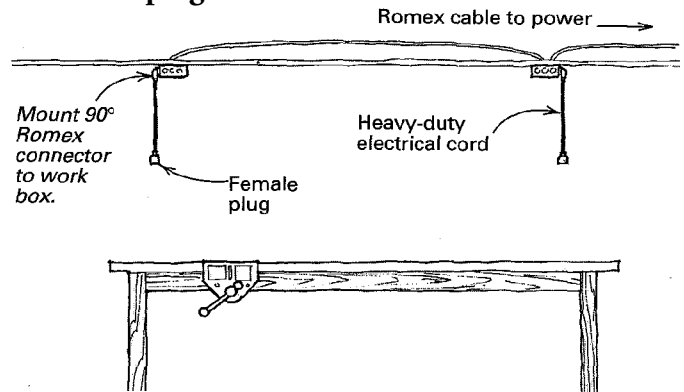

This simple bit of rewiring solves the problem of always having a cord underfoot when using routers, drills and the like at the workbench. Run Romex cable above the ceiling, mount work boxes to joists, and with 90° Romex connectors, drop heavy rubber-covered electrical cord with a female plug. A rubber band or twist tie will keep a long tool cord overhead and out of the way when not in use.
—Eric L. Mynter, Remsen, N.Y.

Quick tip: Because the miter-gauge slot on most tablesaws has been milled to a precise 3/4 in. width, the slot makes a great gauge for checking 3/4-in. thickness-planed stock. Plane in small increments until the stock just slides in the miter-gauge slot.

—David R. Johnson, Apple Valley, Minn.

Drilling deep holes on the lathe

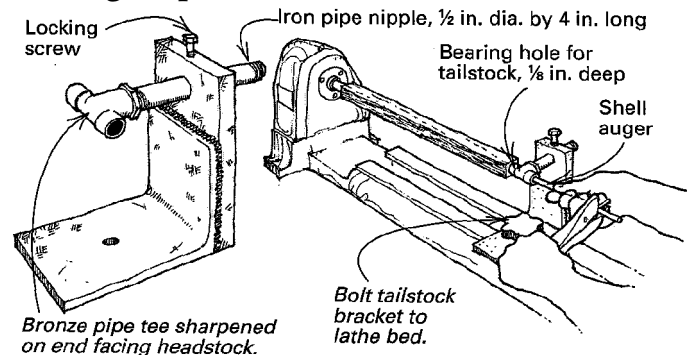

As a maker of traditional wooden fifes, I need to bore long, straight holes in the ends of my flutes. I do this operation on a lathe using an end-boring jig I made from metal pipe and scrap iron. The tool is adapted from a method described to me by Trevor Robinson, who wrote *The Amateur Wind Instrument Maker* (University of Massachusetts Press, 1980). The jig was developed for hollowing fifes, but it works equally well for drilling lamp cord holes or any deep hole in a turned spindle.

Start by making a special tailstock. Take a 1/2-in.-dia. bronze pipe tee, and screw a 1/2-in.-dia. by 4-in.-long iron pipe nipple into the tee. Next weld up a bracket that clamps to the lathe bed with the same hardware used to mount a tool rest. Drill a hole for the nipple through the bracket at the same height as the centerline of the lathe. Then drill and tap the top of the bracket for a locking screw. The locking screw allows you to adjust the pipe assembly for perfect alignment. Then grind around the outside

of the opening of one branch end to make a sharp edge to dig into the end of your turning stock. This sharpened end faces the headstock to support the work during drilling.

To use the fixture, first prepare the stock as follows. Cut diagonal drive kerfs on one end with a bandsaw as normal. On the other end, center-drill an $1\frac{1}{16}$ -in.-dia. hole $\frac{1}{8}$ in. deep. This shallow hole provides a bearing for the tailstock. Where the first hole ends, drill a pilot hole $\frac{3}{4}$ in. deep. Mount the stock in the lathe using the special tailstock. Set the lathe at low speed, around 1,000 rpm. Hold the shank of a long shell auger with vise grips. Drill in the pilot hole through the bronze pipe tee. Because the work is turning and the tool is stationary, the shank of the drill will orbit if the tip wanders off-center. With a little practice, you will learn how to correct this while drilling.

—Walter Sweet, Wellsville, N.Y.

Clamping to bandsaw and drill-press tables

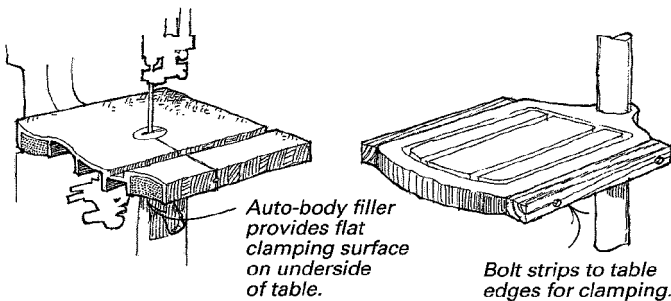

When I wanted to clamp something to my bandsaw table, the stiffening ridges cast into the underside of the table were a real vexation. To solve this problem, I first tried gluing blocks of scrapwood in the voids underneath, but this proved unsatisfactory. Finally, I solved the problem by filling the voids with auto-body filler. Because I don't use large clamps on the bandsaw, I found I only needed to fill the voids along the edge. The filler is quick and easy to install and has worked great for several years.

—Tom Schrunk, Minneapolis, Minn.

Clamping work to my drill-press table was always a problem because the underside of the table is full of ribs, and the edge is too narrow. So I bolted a piece of wood to each side of the drill-press table. This gives me two great flat clamping surfaces.

—James J. Rankin, Easton, Pa.

Trimming plugs

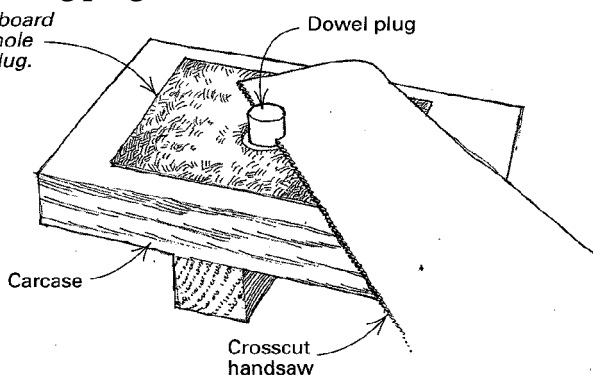

A good plug cutter makes it possible to hide screw heads so that they are almost invisible. I make extras to match both color and grain. When installing the plugs, I orient them with the grain, put a few drops of glue in the hole, stir it around the edges with a wire probe and drive the plug home.

The tricky part comes in trimming the plug down to the sur-

face. To do this, I punch a plug-sized hole in the center of a piece of cardboard and place this over the plug. Then I saw off the excess with an ordinary 10-point crosscut handsaw. The cardboard protects the work and leaves just its thickness to finish off. Don't ever use a chisel for the trimming operation because the plug sometimes chips off below the finished surface. I trim the plug with a finely set block plane; then I sand it flush.

—Kirk Jenner, Grants Pass, Ore.

Quick tip: When rewiring your shop (and if your local building codes will allow), locate the electrical outlets and phone jacks $4\frac{1}{2}$ ft. to 5 ft. above the floor. This will prevent them from being covered by the sheet stock or plywood that you often lean against the wall. The raised receptacles will also allow easy access to power and phone if you place your workbench under them.

—Don A. La Faunce, Eureka, Calif.

Push clamps

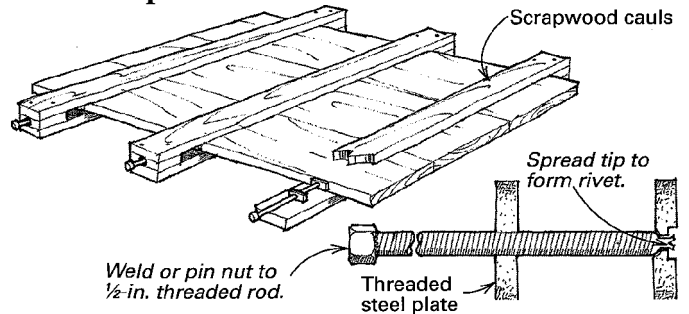

I have only an occasional need to edge-clamp wide boards and have always balked at buying a bunch of sash clamps, not only because of the high cost but also because I don't have the space to store them. So I made several of what I call push clamps, which are simple, small and inexpensive.

To make the clamp, cut a length of $\frac{1}{2}$ -in. threaded rod, and weld or pin a nut to one end. Now cut two plates from $\frac{3}{8}$ -in.-thick strip steel. Drill and tap one plate to travel on the rod. Drill the second plate, and attach it to the turned end of the rod with a loose-riveted joint, as shown. Some ball-and-socket adjustability is incorporated in this joint to allow for minor misalignment. When you are ready to glue up a panel, simply nail and arrange a number of pieces of scrapwood to complete the clamps.

—J. Michael Hayman, Uki, N.S.W., Australia

Drilling pin holes in mortise-and-tenon joints

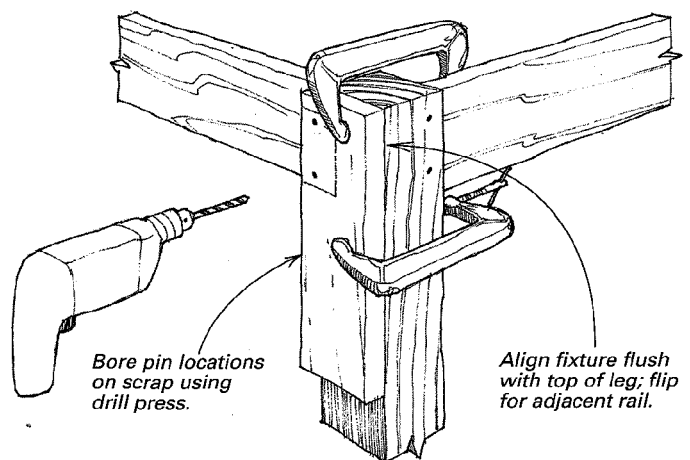

To pin mortise-and-tenon joints in a table frame, lay out the mortise location on a piece of $\frac{3}{4}$ -in. scrap the width of the table leg. Then drill two holes using the drill press at the desired pin

locations. Now position this jig on the table leg flush with the top, and clamp and drill the pin holes into the leg with a portable drill. Flip the jig for the other side of the leg. All holes will be in the correct location, drilled straight with no tearout or wandering.

—C.H. Becksvoort, New Gloucester, Maine

Sliding miter-gauge fence

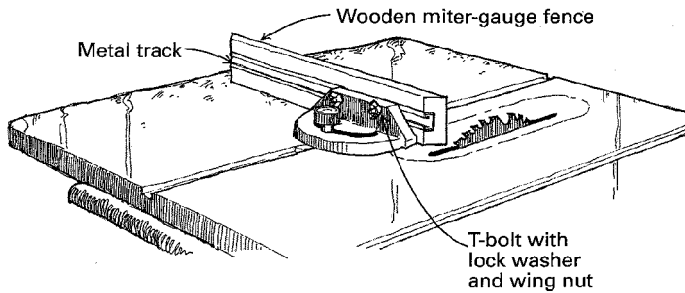

I added a sliding fence to my tablesaw's miter gauge to enable it to perform like the gauges found on many European power tools. With a sliding fence, you can move the end of the fence right next to the blade for a 45° miter cut, then reposition it for a 90° cut. I made the miter fence from a piece of maple, metal track and T-bolts made specifically for jigs by The Woodworkers' Store (21801 Industrial Blvd, Rogers, Minn. 55374). Wing nuts with toothed washers lock the fence in position.

—Don Carkhuff, Darien, Ill.

Beltsanding narrow work

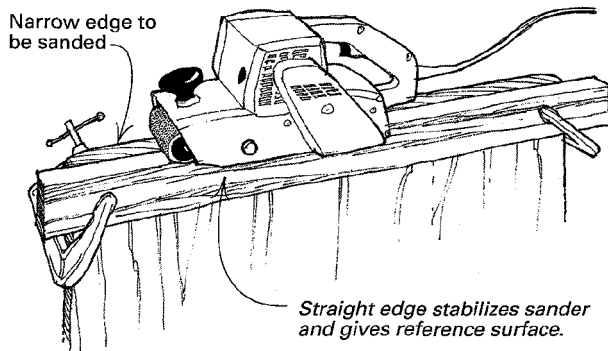

I recently had the problem of beltsanding the edge of a 1-in.-thick tabletop. Try as I might, I couldn't help but rock the belt sander. This resulted in a rounded and uneven edge. I solved this problem by clamping a straight length of scrapwood to the tabletop to increase the surface area for the belt sander to rest on. I used a square to make sure the two surfaces were properly aligned and clamped the scrap piece to the top side of the table to keep from marring it with the clamps.

—Roopinder Tara, Willow Grove, Pa.

Paneled door construction

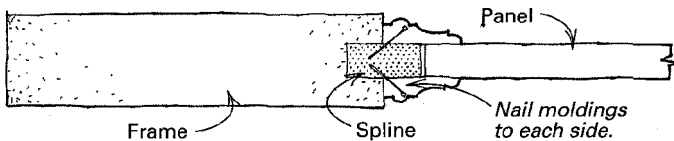

When I was rehabilitating a 1912 home, I discovered this clever trick the builders had used in constructing the interior paneled doors. Start by fitting a spline into the grooved frame. Nail one side of the molding in place. The spline will support and align the molding as it is being fastened. Drop in the panel, and nail the other side of the molding.

—Don Williams, Williamson, N.Y.

Car jack veneer press

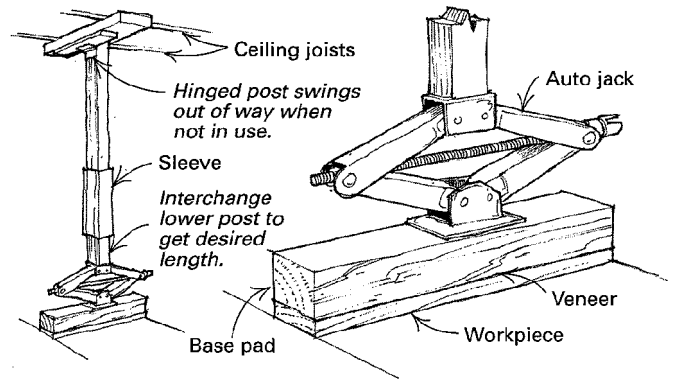

This veneer press is easily made with a scissor-type auto jack and any available lumber. Hinge the arm of the press to a plate that you've attached to the shop ceiling joists. Use a sleeve in the arm to allow different-length lower posts to be inserted, depending on the veneering job at hand.

—Hector Madean, Weston, Ont, Canada

Quick tip: Everyone knows about hickory and mesquite for smoking food because chips are available in those pricey little bags. Less well-known is that scraps and shavings from most common hardwoods like walnut, cherry, oak and maple also work well for smoking. Avoid softwoods and tropical woods.

—Al Pergande, Orlando, Fla.

Remote control for dust-collection system

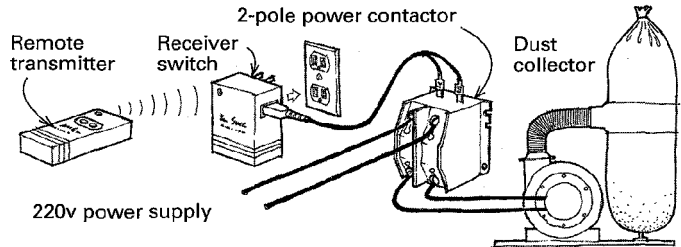

Recently, I had the opportunity to move my custom woodworking business out of my home into a historic mill. As a part of the move, I made several shop improvements, including upgrading to a 2-hp dust-collection system I hooked up to several additional tools. That's when the problem surfaced. I was spending too much time running over to the dust-collector switch.

One evening, I plunked down my weary bones, grabbed the remote and turned on the television. Click. I realized my dust-collector problems were over. I purchased a remotely activated on/off switch from Radio Shack for under \$25, which works like a television remote. By itself, the Radio Shack switch is not beefy enough to power the collection system's motor, so I bought a 2-pole, 30-amp/240v AC contactor with a 110v AC coil and enclosure from my local electrical supply distributor for about \$60. The Radio Shack remote-controlled switch serves as a pilot for the heavy-duty contactor.

After a couple hours of wiring, I could start or stop my collector from any location in the shop, which can be a real time-saver when a customer walks in or the phone rings.

—Jerome Louison, Savage, Md.

Methods of Work buys readers' tips, jigs and tricks. Send details, sketches (we'll redraw them) and photos to Methods, Fine Woodworking PO Box 5506, Newtown, Conn. 06470-5506. We'll return only those contributions that include an SASE.

Disassembly clamp

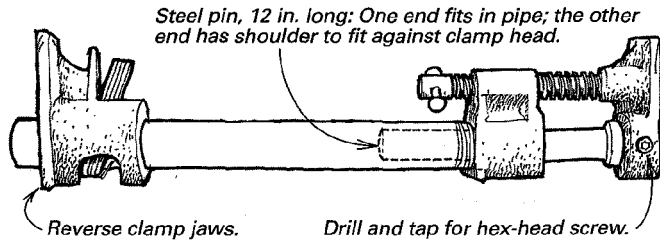

Since I began focusing my work on furniture repair, I have become acutely aware of a pressing need: a clamp that will force pieces apart rather than squeeze them together. I have used Quick-Grip's spreader clamp, but this tool does not exert sufficient pressure when I need to disassemble chair spindles pinned with nails, which is typical of the work that I experience.

My homemade alternative starts with a regular 1/2-in. pipe clamp and adds a 12-in.-long shouldered steel pin. Size the body of the pin for a sliding fit inside the pipe. The pin's shoulder should fit into the pipe-clamp head. If you don't have access to a metal lathe, any machine shop can make the pin. Now just install the pin and reverse the jaws, as shown. Fasten the clamp head to the steel pin by drilling, tapping and installing a hex-head screw.

—Merritt Brown Jr., Panama City, Fla.

Keyhole saw



There are some sawcuts, such as a keyhole shape, that require the control of a hand tool. For such situations, I use a 10-in., 18-tpi metalworking hacksaw blade, bound around its middle with enough electrician's tape to make a comfortable handle. I grind one end of the blade almost to a point, so it can be entered in a hole and used with a pull stroke, thus reducing the risk of buckling or breaking the blade. I leave the other end of the blade unaltered and use it where there is enough space for a push stroke.

—Percy W. Blandford, Stratford-upon-Avon, England

Clamping awkward shapes

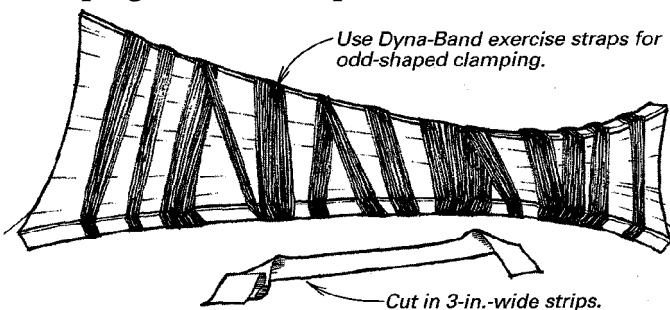

I was having trouble figuring out how to apply laminates to the corners of a sculptural baptismal font when, at an aerobics class, a novel solution presented itself. In the class, we use springy rubber strips called Dyna-Bands for exercise resistance. The strips, which are about 6 in. wide and 36 in. long, come in a variety of strengths. They are available from Fitness Wholesale (800-537-5512) in packs of 15 for about \$1.50 each. I cut each strip in half lengthwise to produce two 3-in.-wide strips.

To use, wrap the first turn around and over itself. This will anchor one end of the band. Now keep wrapping, as shown in the sketch, securing the far end by tucking it under the band. No

need for clips or staples. The wood is not marred, and the edges of the strips are firmly pressed together. You can vary the amount of pressure from just enough to hold things in place to enough to make glue march out of the joint. Glue peels off, and the band doesn't stick to the workpiece. To preserve the strips, keep them in a Ziploc bag with a little talcum powder.

—Charles Schafer, Annandale, Va.

Stand bases from brake discs

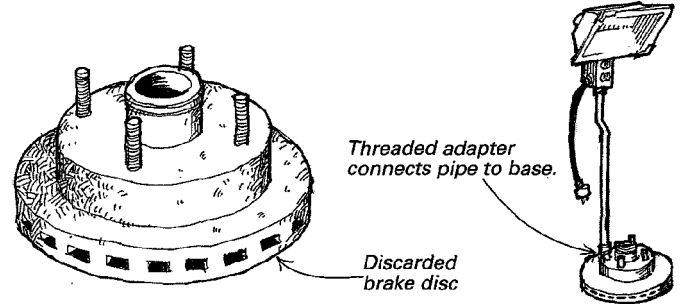

A good source of heavy bases for stands are old brake discs. Auto repair shops throw out discs when they are too thin to be machined safely. You can mount pipe or conduit to the bases by using pipe flanges or making adapters that thread onto the wheel studs.

—Eddie Zanoloso, Pasadena, Calif.

Quick tip: Common household vinegar (acetic acid) makes an excellent rust removal agent. Soaking the rusted tool for a couple of hours will chemically dissolve the rust. Follow this by wiping with a neutralizer, such as baking soda. Then lightly sand with 600-grit silicon carbide sandpaper, and apply three or four coats of furniture finishing wax, allowing each coat to dry about 10 minutes before buffing.

—Robert R. Stagner, Concord, Calif.

Inexpensive faceplate

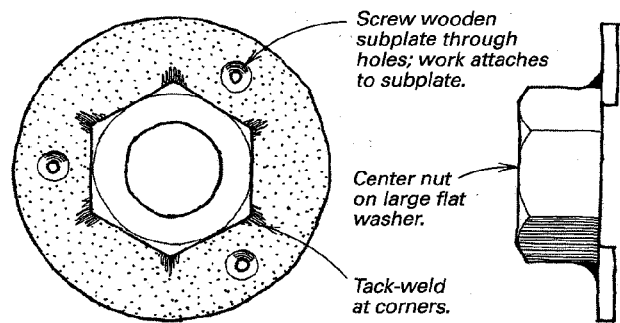

There are advantages to leaving a turning on its faceplate from the first cut through finishing. It eliminates the work of reattaching and re-centering the work and provides a handle to remove the work from the lathe while the finish is wet. But because I may have dozens of turnings in process at any one time, it was unfeasible to mount each on a \$20 commercial faceplate. So I came up with this method for making inexpensive faceplates from hardware store material. The last batch cost \$1.50 each.

The faceplate is nothing more than a hex nut welded to a large flat washer. Select a big nut to fit your lathe's headstock and a large, thick washer with an inside diameter smaller than the nut. Center the washer on the nut, and clamp with two small C-clamps before welding. If the nut and washer are plated, grind away the plating in the welded area.

Now tack-weld the nut to the washer at all six corners. It is better to stagger the welds rather than weld around the nut in sequence. This lessens the chance of warping the washer. Clean off the weld splatter, and countersink three holes in the washer.

Only rarely will the steel portion of the faceplate run true. So attach a wooden subplate to the faceplate, and turn it to eliminate any wobble. Attach the work to the wooden subplate.

—Robert Calvert, Squaw Valley, Calif.

Quick tip: When cutting a dado with a backsaw, tack down a wooden straightedge for a guide.

—Gary Gene Gautier, Surbiton, Surrey, England

Making knobs

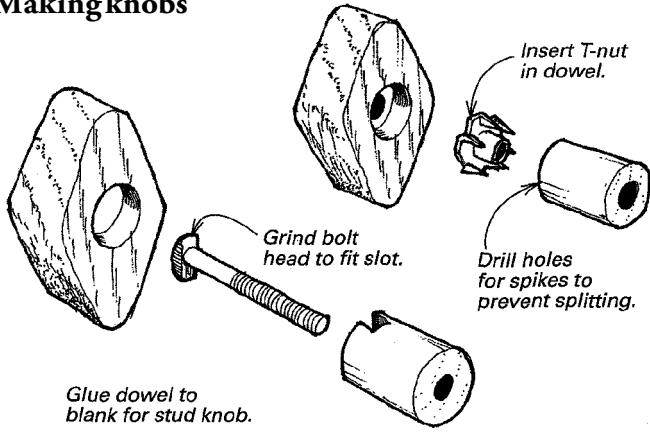

I use lots of jigs in my shop, so I always need odd-sized knobs and handles. Here's how I make them. There are two types, stud and captured nut, both use a 3/4-in. dowel insert. To make the stud knob, cut a slot in the end of the dowel insert to trap the bolt head you've modified by grinding. To complete the knob,

put a little glue on the dowel, and press it into the knob body. The captured-nut knob has a similar dowel, which traps a T-nut. Drill a 1/8-in. hole for each spike to keep the dowel from splitting. Size the hole through the knob slightly larger than the bolt, so the knob will spin on and off easily.

—Bill Tenny, Canfield, Ohio

More knobs

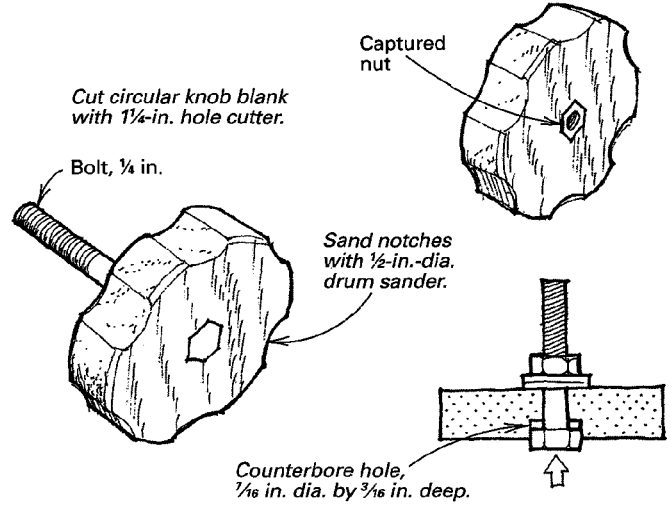

To make a stud-type knob, cut a circular knob blank with a 1 1/4-in. holesaw fitted with a 1/4-in. pilot bit. Counterbore a 7/16-in.-dia. hole 3/16 in. into the face of the knob. Insert a 1 1/2-in.-long,

$\frac{1}{4}$ -in. bolt in tile pilot hole and, using a couple of washers and a nut, tighten with a wrench until the bolt head is pulled flush to the knob body, as shown. Soften the arris (top edge) of the knob blank, and sand indentations around the knob, if desired, with a $\frac{1}{2}$ -in.-dia. sanding drum.

The captured-nut knob uses the same principle but with a slightly different installation method (see the drawing) to pull the nut flush.
—John Plank Sr., Waupun, Wisc.

"L" push stick

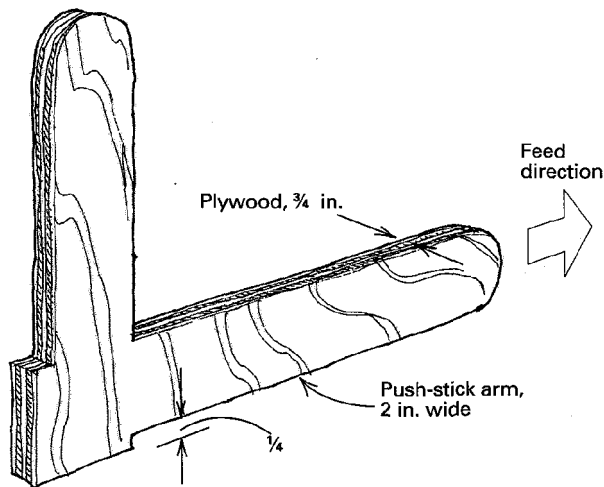

Fifteen years ago, Norman Buchholz showed me the best push stick that I have ever seen. It works equally well at the jointer and

the tablesaw; either arm can be used as a handle. Make the sticks from $\frac{3}{4}$ -in. scrap plywood, and jettison used ones regularly.

—M. Felix Marti, Ridgway, Colo.

Pouring liquids into small openings

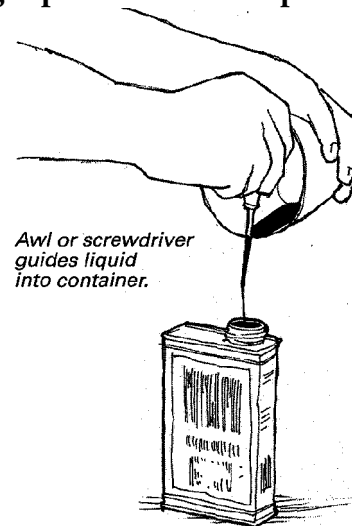

I like to pour my finish oil into a bowl to make it easier to apply. To return the unused oil to the container, I use a trick learned in college chemistry. Hold a scratch awl or screwdriver against the edge of the bowl, and pour the liquid onto the tool as it is held over the hole of the container, as shown. Surface tension will keep the oil flowing along yet clinging to the tool until it enters

the container. Steady hands and practice will enable you to return any liquid to its container without a mess. Wipe the tool dry when you're done.
 —William Roberts, Bend, Ore.

Homemade cabinet leveler

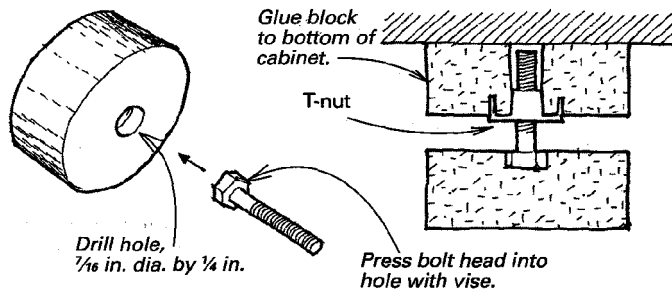

To make this cabinet leveler, slice $\frac{3}{4}$ in. off the end of a 2-in.-dia. hardwood dowel. Bore a $\frac{7}{16}$ -in.-dia. hole, $\frac{1}{4}$ in. deep, into the center. Now force a $\frac{1}{4}$ -in. hex-head bolt head into the hole with a vise. The dowel will fit surprisingly tight. To complete the adjustment mechanism, attach a T-nut to a hardwood block, and glue the block to the bottom of the cabinet.

—Mark Smith, Hamilton, Ont., Canada

Quick tip: Stair tread, which is usually 1-in.-thick clear yellow pine with a bullnose profile on one edge, looks better, costs less, is easier to find and is stronger than run-of-the-mill yellow pine. Trim off the bullnose to yield a usable width of about $10\frac{3}{4}$ in., or incorporate the shaped edge into your project.

—Thomas W. Chadwick, Estell Manor, N.J.

Making cork pads

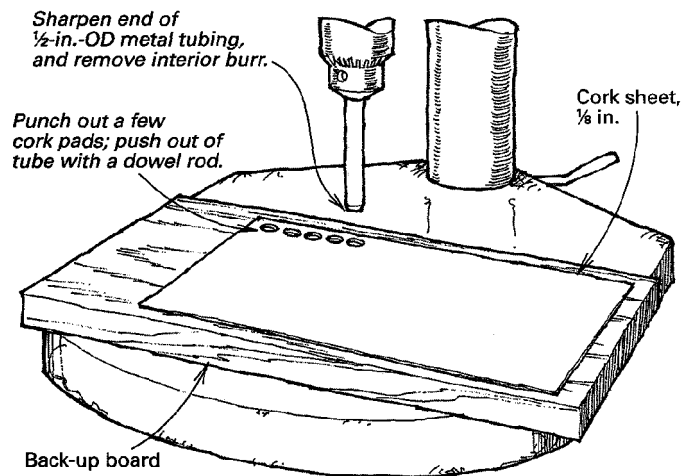

It seems wickedly extravagant to order a small package of cork disc furniture pads for my music boxes, pay inflated shipping and handling charges and wait a week or more when I can make hundreds in my own shop for pennies.

Start with a short length of $\frac{1}{2}$ -in.-OD steel tubing, which is easy to find in most machine-shop scrap bins. Grind one end of the tubing to a sharp cutting edge, and remove the interior burr. Now purchase a 1-ft.-sq. sheet of $\frac{1}{8}$ -in. cork at your local hobby shop. Insert the tube in your drill press, and then lower the quill just enough to score a circular impression on a piece of scrap lumber. (The indentation will allow the tube's sharpened tip to

completely pierce the cork.) Leaving the scrap as a back-up, start plunge-cutting discs. When you have cut about eight or so, remove the tube, and push out the cork buildup with a dowel rod. Attach the pads to your work with a dab of white glue.

—Jim Tile, Fayetteville, Ark.

Improvements for a drill-press auxiliary table

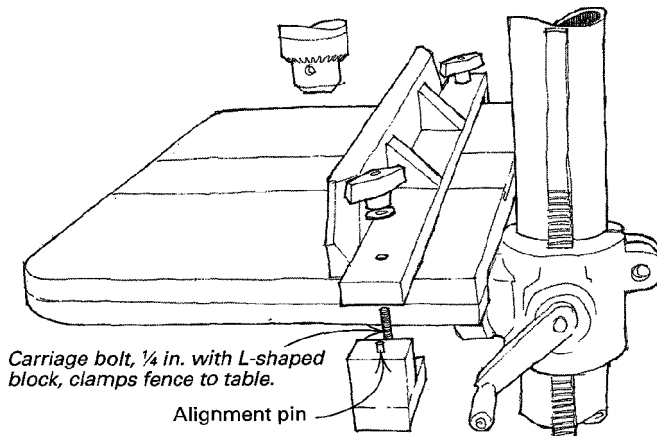

I was glad to see David Harvey's idea for an auxiliary drill-press table (*FWW* #101, p. 12) because I had recently purchased a floor-standing drill press. However, when I built my auxiliary table, I modified the fence so that it would position easily and have more range.

The primary modification to the fence is the clamping device. This is simply a 1/4-in. carriage bolt through an L-shaped block

that, when tightened, grips the bottom of the table. A steel guide pin, made from the shank of a salvaged bolt, keeps the block lined up.

—Arthur W. Griggs, Glencoe, Ill.

Simplified dust-collector switch

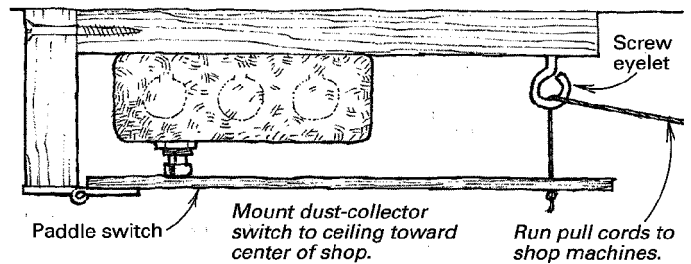

Over the years, I have seen several designs in *Fine Woodworking* for switching a dust-collection system on and off. All seemed too complicated or impractical for my situation.

My alternative is a simple mechanical system using a cord, much like what is used on a city bus to signal the driver for a desired stop. I located the switch box at a convenient central location on the ceiling of my shop. Then, by running several cords to different areas of the shop, I am able to turn the dust collector on or off simply by reaching up and pulling the cord from whatever machine I am using.

—Kim Anderson, Loyalton, Calif.

Methods of Work buys readers' tips, jigs and tricks. Send details, sketches (we'll redraw them) and photos to *Methods*, *Fine Woodworking*, PO Box 5506, Newtown, Conn. 06470-5506. We'll return only those contributions that include an SASE.

Scribing accurate kerf lines with machinist's dye

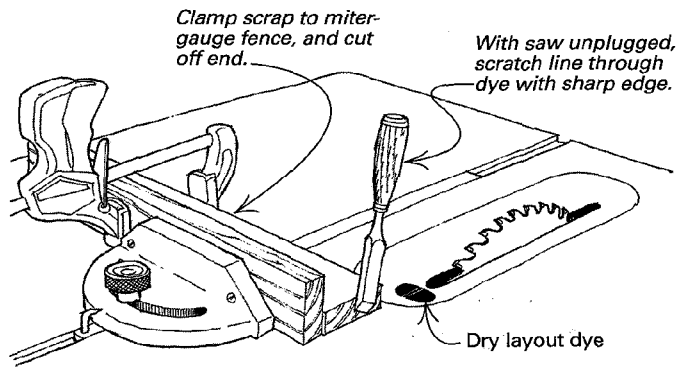

I have improved the speed and accuracy of my tablesaw cuts by scribing precise, easy-to-read cut lines on the throat plate. To make the lines, apply machinist's layout dye to a small area of the plate, and let it dry. Clamp a piece of scrap to the miter gauge, and cut it off. Using the freshly cut edge of the scrap as a guide, lightly scribe a line in the dye. Repeat this operation on the right side of the blade to give two lines. The dye makes the lines stand out, and it can be removed with alcohol and the process repeated when the blade is changed.

—Gladden Griggs, South Bend, Ind.

Double-headed combination square won't slip

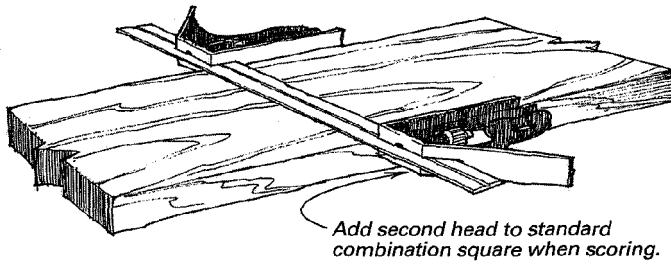

I added a second head to my combination square. By bringing this second head to bear against the parallel edges of a board, the possibility of slippage is reduced when I'm using the square as a marking guide or when scoring with a lot of pressure.

—Leonard H. Feldberg, Chestnut Ridge, N.Y.

Drum-sanding tool handles small work

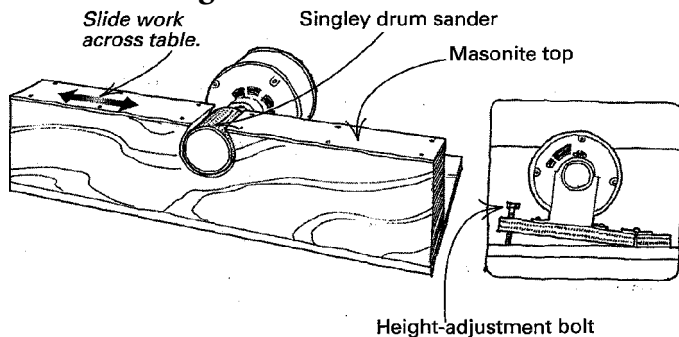

Sanding small pieces with an orbital or belt sander is a chore because there is no easy way to hold the pieces while sanding. So when I had to sand lots of little slats for a bed project, I was inspired to build this tool. I simply slide the workpiece across the sander's table. It sands narrow edges as well as broad flats and does not round over the corners, unless you want them rounded.

One of the advantages of a drum is that it contacts the work for only about 10° and has the remaining 350° to unload the dust.

That characteristic, combined with a vacuum attachment, makes for very clean sanding and long abrasive life. The big disadvantage of a drum is that any hesitation in the feed will put ripples in a flat surface. The table on this tool makes it easy to slide the work across at a controlled, uniform rate and avoids the ripples.

Construction is straightforward. I used 3/4-in. plywood for the base and covered the tables with 1/4-in. Masonite. Drum-height adjustment is provided by a hinged table under the motor. I use J-weight resin-bonded, resin-coated abrasive cloth on a Singley drum (Singley Specialty Co. Inc., P.O. Box 5087, Greensboro, N.C. 27403). The 3x3 drum I use has a 1/2-in. bore, which will fit common motor shafts. For work that has been planed, I start with 180-grit sandpaper and follow with 320-grit.

—Eugene C. Hise, Oak Ridge, Tenn.

A better dovetailing chisel

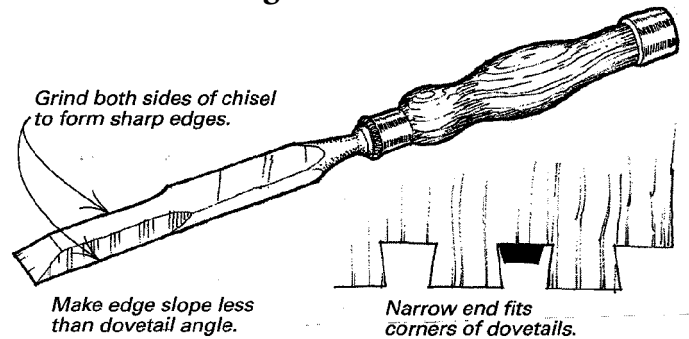

Ordinary chisels bought for the purpose of chopping out dovetails are beveled on the top. This bevel, however, is really more of a chamfer that leaves a flat of about 1/16 in. or so, which prevents pushing the chisels completely into acute corners. To correct this problem, grind both sides of a square-edged chisel across to a sharp cutting edge. Select an angle slightly less than your usual dovetail angle to allow the tool to trim right into the corner of the tails.

—Percy W. Blandford, Stratford-upon-Avon, England

Quick tip: To soak a hardened paintbrush, insert the bristles into a sandwich-sized freezer bag. Pour in a few spoonfuls of solvent, and close the bag around the ferrule with a rubber band. Stand the bagged brush in water up to the ferrule. This will squeeze out the air and ensure the solvent wets the whole brush.

—Don Stewart, Bellevue, Wash.

Trailer ball makes a machine mover

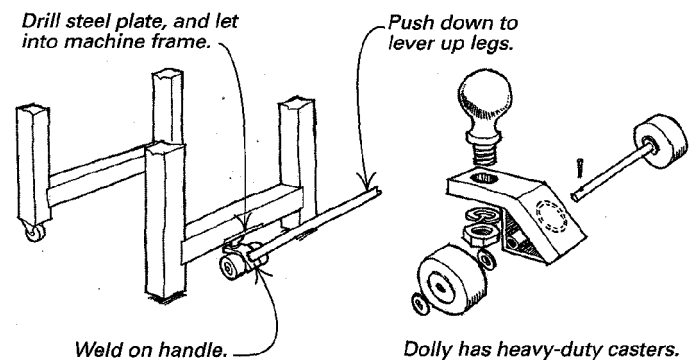

Many of the techniques for making machine tools portable involve putting wheels at one end, fixed legs at the other end and installing handles to lift and push the tool like a wheelbarrow. Here's a variation that came to me while watching boats on trailers being moved around in a boatyard with very little effort.

First build the tool base with heavy-duty casters on one end

and a crosspiece fitted with a steel plate at the other. If you have several stationary tools, make the height of the crosspiece the same on each tool. Now weld up a wheeled dolly bar, as shown in the sketch. Use high-strength structural tubing, such as ASTM A50, and solid bar stock. Water pipe is too weak and will bend. A welding shop will have these materials on hand and will probably do the job quite reasonably.

To move the tool, locate the trailer ball in the steel plate on the underside of the crosspiece. Push down on the handles to lever the legs off the floor. Now push or pull the tool into place.

—Glenn D'Onofrio, Downey, Calif.

Quick setup for routing grooves

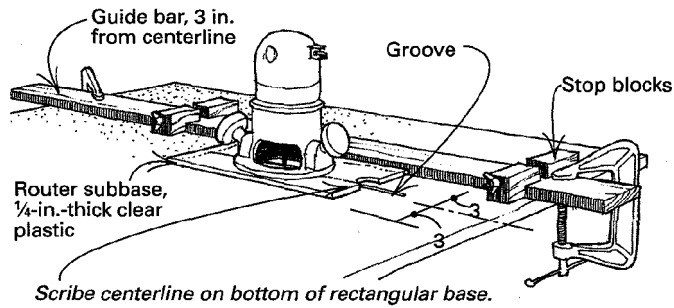

Recently, I had to rout some slots at odd angles for a display rack. Here's the method I devised. Lay out the grooves on the project, and draw a centerline through each one. Make a rectangular base for your router from 1/4-in.-thick clear plastic by scribing a centerline through the base centered on the bit. Then

trim both edges 3-in. away from the centerline. You can now use the base like a drafting template to set up the router.

To use the base, retract the bit below the base. Set the router over the centerline of the groove, and place a guide bar against the plastic base, parallel to the cut line. Clamp the guide bar in position. The guide bar should be 3-in. away from the center line. If the grooves are stopped, you can add stops to the guide bar. Mine are two L-shaped pieces of wood tightened with a bolt and wing nut.

—Richard Herst, Redondo Beach, Calif.

Cutting perfect miters on the tablesaw

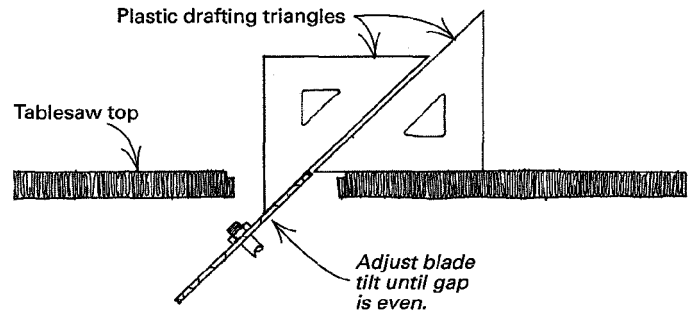

When trying to rip beveled miters or crosscut perfect miters on a tablesaw, the 45° blade setting is usually anything but. And if the angle is off even a little, the cumulative error makes that fourth corner gap in your assembly very noticeable. Here's how to ensure virtually perfect miters. Buy two 45° plastic drafting triangles, one clear and one colored (for better visibility), and set them up on the blade as shown. You will only be able to get

about 3 in. of the triangle down on the blade, but this should be enough. Hold the second triangle on the saw table, or clamp it between two pieces of scrap. Adjust the blade until the gap is even; the long bases of the triangles exaggerate the gap

—James H. Wolfe, Enumclaw, Wash.

Quick tip: To remove excess glue squeezed out of a clamped joint, first scoop up the bulk of the glue with one of the loose subscription cards found in each issue of *FWW*. Next, grab a handful of sawdust, preferably from the wood being glued, and rub it around, which will create little balls of glue and sawdust that will remove all traces of the glue.

—Phil Hall, N. Berwick, Maine

Straight line ripping fixture is fast, accurate

Set wheel at angle to push work against fence.

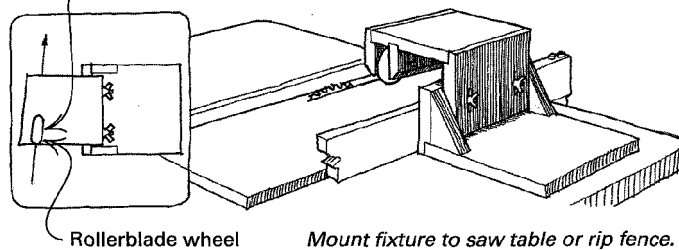

Here's a fixture I built for keeping work tight against the table-saw's fence. It allows accurate, fast ripping in production situations. The heart of the fixture is a common wheel from an in-line

skate or Rollerblade, which comes complete with precision bearings. When building the fixture, angle the wheel slightly toward the fence. This will apply inward and downward pressure on the workpiece as it rolls under the fixture.

—John Chung, Santa Barbara, Calif.

Honing jointer knives into perfect alignment

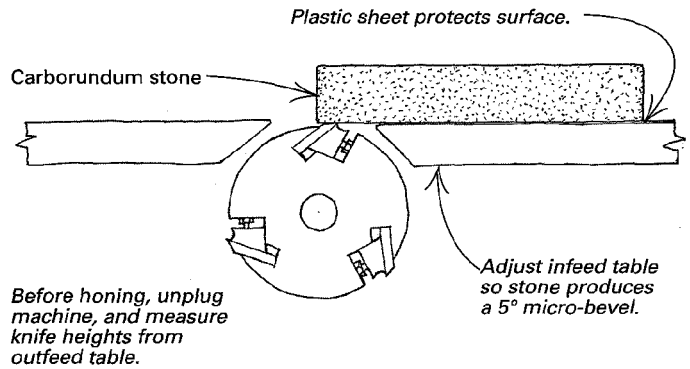

Most of the problems with jointer-knife setup happen after the blades have been perfectly aligned—when they are tightened. The tensioning of the holding screws invariably will cause some blade movement or distortion, which is virtually impossible to anticipate and counteract. My solution is to set the blades as close as you reasonably can, but still just a bit high, and then sharpen them to alignment.

With the machine unplugged, use whatever method you prefer to get basic alignment. Tighten the blades, and then measure

how high they are from the outfeed table using a dial indicator. Rotate the blade forward, lock in place and lower the infeed table, using it as a guide for a Carborundum stone to grind a micro bevel. Protect the infeed table with a thin piece of plastic. Grind the micro bevel until it is consistent along the knife's length. If you have aligned the knives to .003 in. high to begin with, for example, you'll need about 3 to 5 minutes per knife to hone the knives by hand to where you want them. After honing, I normally leave the knives about .001 in. high because the height will diminish as the blades wear.

The real beauty of this system is that you can custom-grind exact blade alignment even on bowed blades or on the out-of-round cutterheads of older machines.

—Thomas R. Schrunck, Minneapolis, Minn.

Drying board saves time in finishing

A simple drying board I make in seconds has saved me many hours during the finishing stages of my projects. To make it, just shoot staples from a staple gun through a piece of corrugated cardboard at regular intervals making a grid of staple points protruding through the other side. The spacing can be several inches for large projects or very close together for small ones. Lay the board flat, points up.

Apply the finish to the bottom of your project just as you normally would. While the Finish is still wet, set the bottom of the project on the staple points of the drying board, and then immediately apply the finish to the top side of the project (no waiting). The staple points allow air to circulate under the project to dry the finish, but the points leave little or no visible flaws on the bottom of the project. —Larry Wiese, Newport News, Va.

Routing the edges of odd-shaped pieces

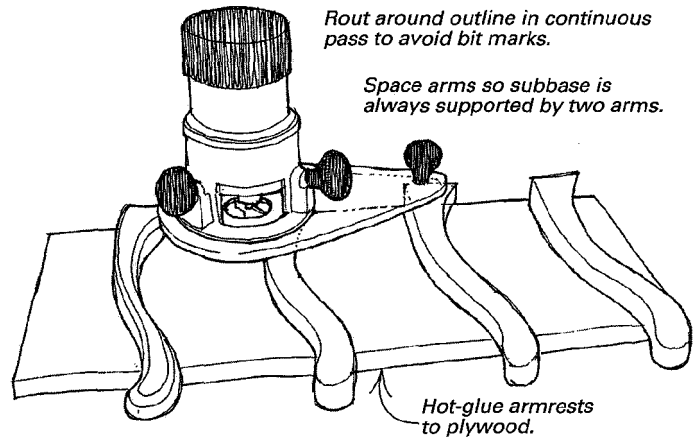

Shaping edges on small pieces with a router is always ticklish. I was recently faced with this problem when I needed to round over edges on some one-half scale tapered walnut rocking-chair arms. My magic mat wasn't stable enough. And because I wanted to round over the perimeter in one pass to keep the cut smooth, I didn't want to clamp and reclamp each arm. Also, I needed to prevent the router from rocking on the small surface.

I solved the problem by hot-gluing all four armrests to a scrap piece of birch plywood, spaced 8-in. apart, in line and parallel. I used the extended subbase on my router supported by the adjacent armrest to steady the router. After shaping one side, I pried the armrests off and flipped them over to rout the other side.

It took only two little dabs of hot glue on each armrest to hold them. The dried glue, and occasional flakes of plywood veneer, were easily removed with a scraper. I've since used this technique successfully on other small parts where I needed a stable base and didn't want to spend a lot of time clamping and reclamping each piece.
—Dave Coumes, Franklin, Tenn.

Shopmade miniature vise clamps small parts

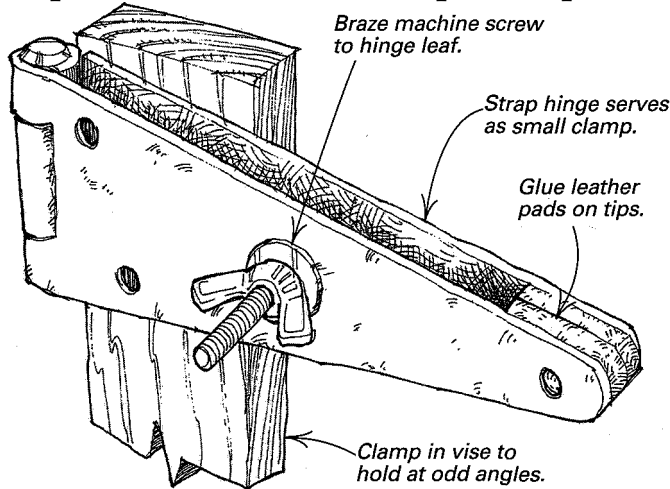

I saw a street jeweler using this homemade device as a ring clamp. It consists of a strap hinge, machine screw, wing nut, spring and two leather pads. Braze or silver solder the machine screw to the hinge. Then attach the vise to a length of hardwood so that you can clamp it in your bench vise at any angle.

—Ted Walton, Hilton Head Island, S. C.

Grinder tool-rest gauge makes setting easy

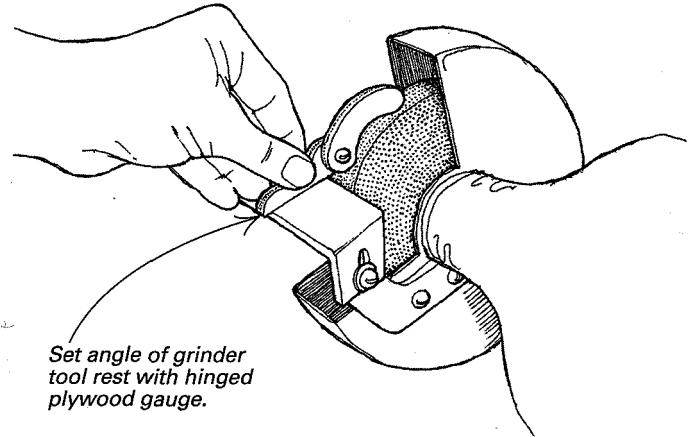

When going from the coarse to the fine stone on my bench grinder, I always had trouble getting the tool rests at the same angle. The solution was to develop a simple shop-built gauge. With this two-piece adjustable 1/4-in. plywood gauge, I can now align the tool rests with ease, assuming the grinding wheels are about the same diameter. Starting on the coarse wheel, I position the gauge to the tool rest I then move the gauge to the fine wheel and adjust the tool rest to the gauge.

—Robert Vaughan, Roanoke, Va.

Methods of Work buys readers' tips, jigs and tricks. Send details, sketches (we'll redraw them) and photos to *Methods*, Fine Woodworking PO Box 5506, Newtown, Conn. 06470-5506. We'll return only those contributions that include an SASE.

Horizontal vise lends an extra hand

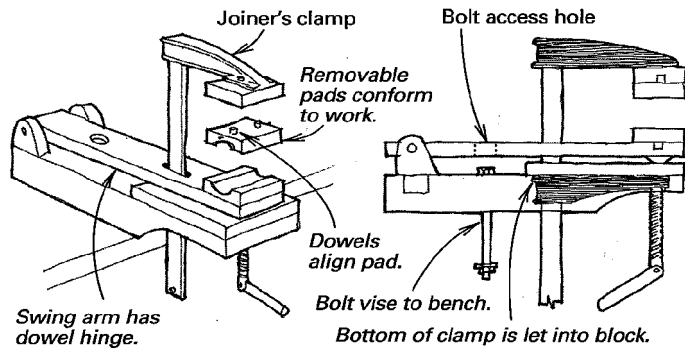

In the course of repairing furniture, I often need to hold irregular shapes in a horizontal position. So I made a horizontal vise using a Record joiner's clamp. I let it into an oak base, which I temporarily bolt to my bench when the vise is in use. Remove the stop pin from the joiner's clamp bar, so you can position the clamp with its fixed side above and its screw side below the vise. The lower side of the vise features a swing arm between the work and the vise screw. The swing arm pivots on a dowel hinge. Both the upper and lower jaws are drilled with two holes to receive specially shaped wooden jaw pads that have dowel-alignment pins. I have several pairs of pads shaped to fit the different profiles that I encounter.

To use the vise, I lift the fixed arm, place the work between the jaw pads and lower the fixed arm onto the work. A few turns of the handle secure it. —William. D. Edwards, Burlingame, Calif.

Quick tip: For turning small spindle stock between centers, buy an extra cup center, and use it on the headstock as the drive center. If you have a dig, it will act like a clutch, spinning in the workpiece. Also, if you happen to touch it when working close to the headstock, it will not eat your gouge like a spur centerwill. —Geordie Smith, Ruddell, Sask., Canada

Router-table mount allows height adjustment

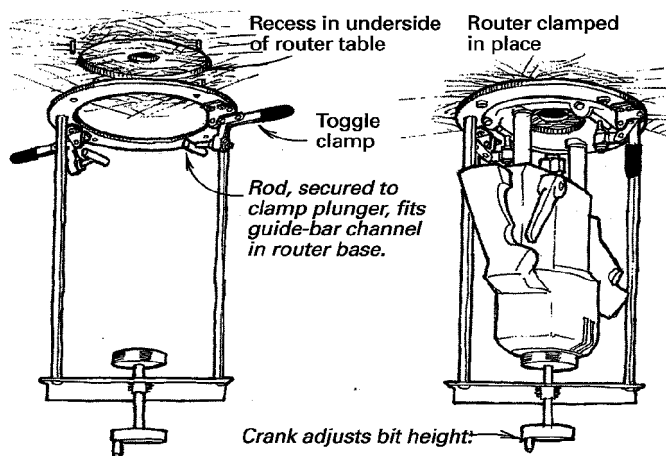

To enable me to rapidly insert and remove my router from my router table, I built the toggle-clamp fixture shown in the drawing above. I removed the rubber cushions from the clamps and substituted short sections of steel rod, tapped through the middle like barrel nuts. The rods clamp into channels (for edge-guided rods) molded in my router's base.

The fixture also features an easy-to-use height-adjustment screw, which is simply a length of threaded rod fitted with a crank on the bottom and a pressure-dispersing disc on top. The screw eliminates the problem of having to overcome the

combined force of the plunge router's weight and the spring pressure when making small height adjustments.

The all-metal fixture in the drawing does require moderate metalworking skills and access to some metalworking machinery. However, many of the components could be replaced by wooden counterparts. —Philip Blume, Albuquerque, N.M.

Edge-gluing setup handles angled boards

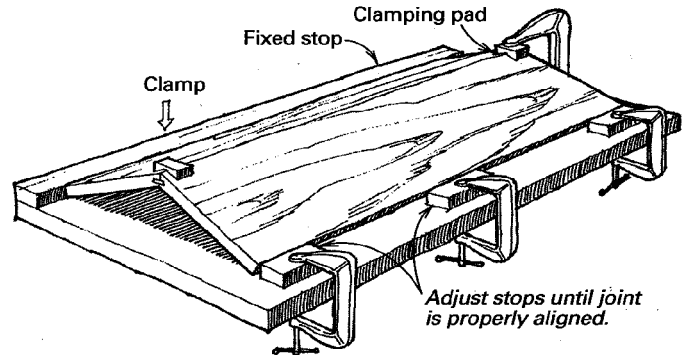

After many trials and some wasted materials, I finally discovered this effective technique for clamping boards that are at a slight angle. Dry-run the clamping until the stops are located perfectly. I'd recommend using a slow-setting glue such as Franklin hide glue. If needed, clamp the central area of the boards by running a caul across them with a clamp on each side.

—W.G. Sheard, Horseheads, N.Y.

Fluting jig guides router

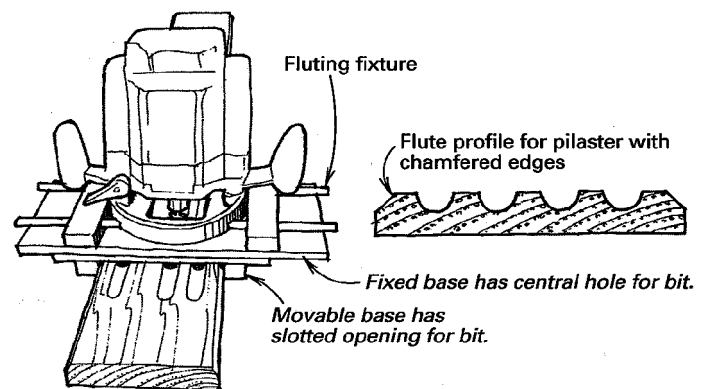

Fluting in flat surfaces adds grace to fireplace surrounds, doorway casings and the like. This router jig simplifies the process.

Start by building a guide carriage with two parts: a fixed base that attaches to the router and a movable base that straddles the workpiece. I used 3/8-in.-thick Baltic-birch plywood, but any similar dense material will do. It is possible to fasten the two parts of the jig together with wing nuts and slots. But because there are usually only two settings, I screwed the two parts together with six wood screws.

Tradition dictates four or five flutes. I like to use four flutes because I can get the maximum effect with the minimum of router settings. Either way, lay out the profile of your flutes on a piece of paper to determine the spacing of the flutes (the layout shows you the settings for the jig). Remember that you will be making identical cuts from both edges of the workpiece, so only two settings will yield four flutes. Draw index marks on the fixed base to show where you will attach the movable base.

Get the feel of your jig by making practice runs on a scrap cut-off. Take note of the following:

- The movable base must straddle the stock so that it slides

freely but with minimal slop in the fit. This requires the stock to be perfectly uniform in width.

- Use new or freshly sharpened core-box bits. Dull bits are hard to push and leave burn marks.

- Check the spacing of the flutes with only two of the six base screws in place. Adjust the settings of the movable base if necessary. When the spacing is perfect, screw the movable base to the fixed base with all six screws.

- Use a variable-speed router, if possible, and slow the speed at either end of the flute.

- Draw the router to you. Make several passes, and finish with a fine cut.

- Use a good respirator mask and a pair of goggles.

—William D. Lego, Rockford, Ill.

Cutting angled tenons on the tablesaw

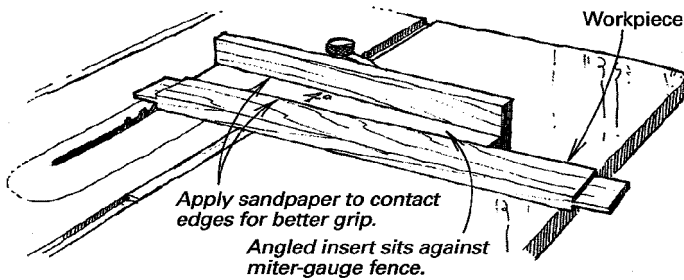

When cutting angled tenons like the kind needed on aprons of tapered-leg tables, using your tablesaw's miter gauge can be prone to error. And setting the miter gauge to the exact but opposite angle to cut the other side of the tenon is time-consuming.

An easy solution exists. Cut your desired angle in a long piece of scrap, and then insert the scrap to add or subtract this angle from your normal 90° setup. If the miter gauge's 90° fence is accurate, the opposites will match exactly. Add a strip of sandpaper to the contact surfaces of the scrap to prevent slippage.

—Robert J. Clark, Holland, Mich.

Tapering jig can handle small pieces

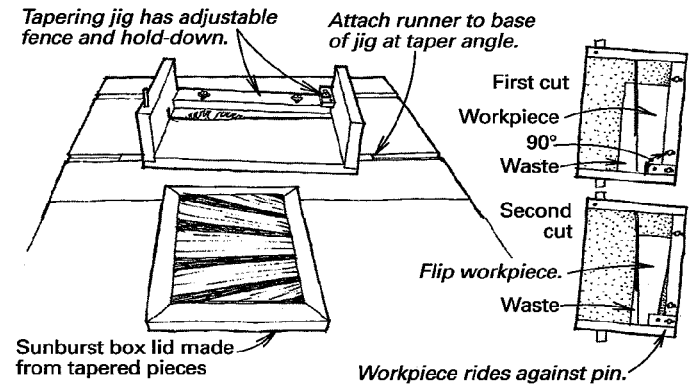

My jewelry boxes feature a sunburst pattern on the lid, which I make by gluing up nine or so tapered pieces into a fan shape. The jig that I use to cut these small tapered workpieces on my tablesaw is built like a miniature sliding crosscut table. One big difference, however, is that the runner (which fits in the table-saw's miter-gauge slot) is attached at an angle to the centerline of the jig. The runner angle should be half the desired taper an-

gle, which for my jig is 4°. An adjustable fence to the right of the kerf determines the width of the tapered piece's wider end. The lower end of this fence has an adjustable hold-down that registers the workpiece for the second pass. With this jig, you can vary the width of the workpiece but not the taper angle.

Equally taper both edges of the work. Here's how I do it: I draw each tapered piece to scale, and then I measure the dimensions. Next I set the jig's fence to the width of the workpiece's wider end (the end that meets the sawblade first), and I make the first taper cut. I place a brass pin (stored in the jig's rear cross brace when not in use) in the hold-down and adjust the pin to the width of the trapezoid's narrower end I flip the blank over and make the second cut.

—David M. Freedman, Cross Plains, Wis.

Make oval frames with only one cutting angle

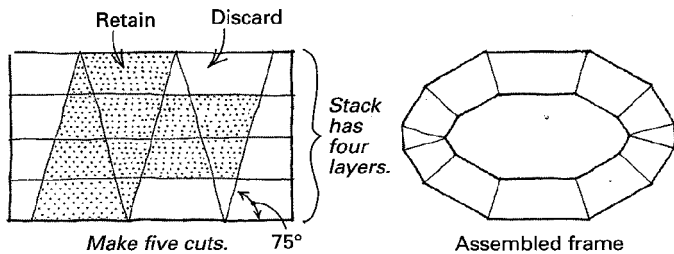

While building a small oval box, I worked up a system for elliptical frame construction that may be useful for oval mirrors and the like. It is basically a staving system, but the advantage is that only one miter angle is needed. Stack four layers, and make five

crosscuts through the layers at 75°. The resulting pieces will assemble into an oval-shaped frame, as shown in the drawing.

—Lee E. Dunbar, Elkton, Va.

Quick Up: To help visualize turned designs, hold a mirror at 90° to the outline of one-half of the turning. Change the position of the mirror until you like the design you see, and then mark along the edge of the mirror to record the centerline of the pattern.

—Virgil Martin, Orrville, Ohio

Crosscutting tapered legs on the radial-arm saw

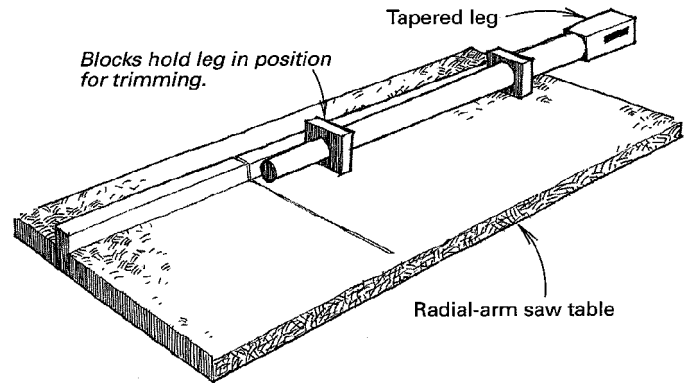

Recently, I had to shorten some factory-made tapered legs. To make sure the cut was perpendicular to the centerline of the legs, I used the following simple method: I cut two identical squares larger than the diameter of the leg. Then I drilled a different-size hole in each of the squares. When the squares

are pushed onto the leg, one is wedged near the small end and the other near the big end. When pressed against a radial-arm saw fence, the blocks will hold the leg in exactly the right position for cutting. The system can be used with round or square tapered legs.
—Bernie Badler, Castro Valley, Calif.

Quick tip: Use cooking oil (Mazola corn oil, for example) to safely remove spots of polyurethane from your hands. Simply rub about a spoonful on the area, and then wash with soap and water. Cooking oil is also a great solvent for pine pitch.
—Jim Van Dreesse, Wisconsin Rapids, Wis.

An all-wood winch

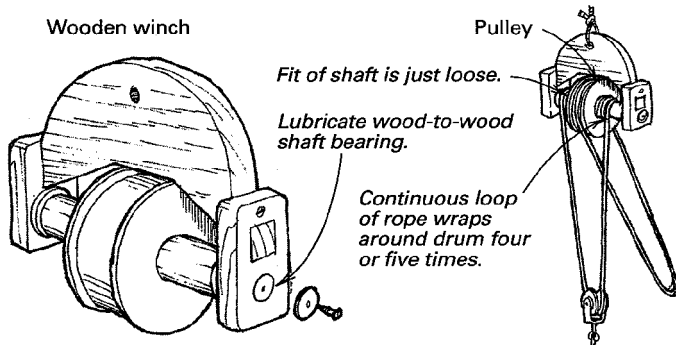

Lathe-tool pouch puts turning tools at easy reach

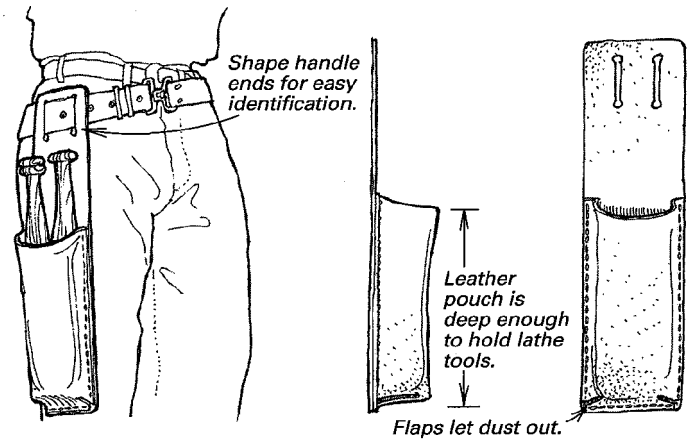

I have a very small workshop. So some heavy tools have to share a single stand. To make it easier to mount and dismount the tools, I built an all-wood winch. It serves its purpose well.

Most of my turning is done with only three lathe tools. When I got tired of losing them under mounds of sawdust, I designed a belt pouch like the knife pouch butchers use. The pouch is a rigid leather tube, closed at the bottom, that hangs from the tool belt at my side like a gunslinger's holster. I sized the pouch deep enough to contain all of a turning tool's blade and about half the handle, which is enough to prevent tools from falling out.

After you get a slightly loose fit of the shaft to its bracket, lubricate the wood-to-wood surfaces. To operate the winch, wind a rope around the inner drum four or so turns to provide a no-slip grip. Splice the other end of this rope so that it forms an endless loop. The force one has to apply to the winch rope is about one-fourth the weight lifted.

—Abe Peled, Ramat-Hasharon, Israel

I turn my own tool handles, so I made each of the handles distinctive enough that I can identify the tool just by touch. This allows me to quickly change tools without having to take my eyes off the work.

—Anthony W. Clarke, Moonta Mines, Australia

Wall-mounted saw hanger secures blades

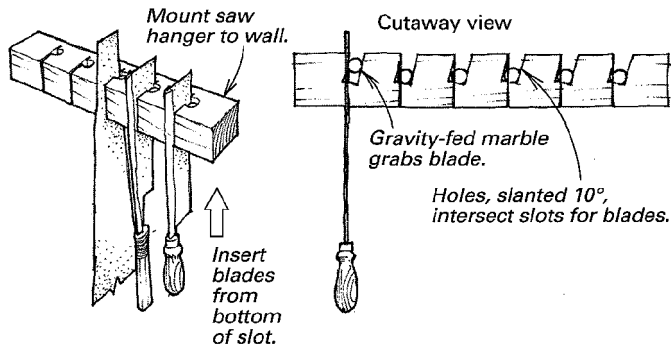

1/2

Gravity will pull the marbles down to pinch against the blade and hold it in place.

—Robert Andrews, San Diego, Calif.

Making a curved sanding block

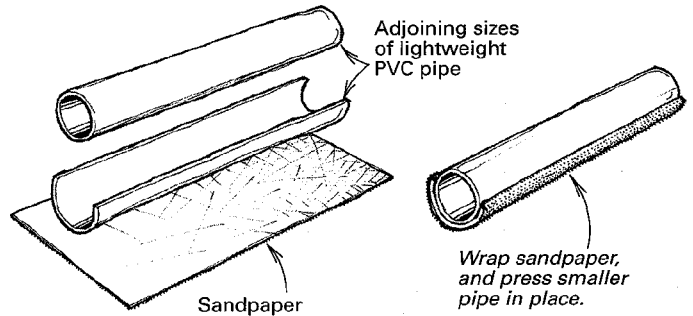

Here is an easy way to make a curved sanding block for cove or circular holes. Split a piece of PVC 20 (the lightweight, cheaper stuff) lengthwise on the tablesaw or bandsaw, so you have just over a full half cylinder. Size the sandpaper so that it wraps around the half cylinder with an extra 1/2-in. flap on both sides. With the sandpaper in place, snap the block over a length of the next smaller size pipe to hold the sandpaper in place. Because this works with any two steps in size, you can vary the radius from 1/2 in. to 2 in.

—Kenneth E. Vinyard, Medford, Ore.

Methods of Work buys readers' tips, jigs and tricks. Send details, sketches (we'll redraw them) and photos to *Methods*, Fine Woodworking, PO Box 5506, Newtown, Conn. 06470-5506. We'll return only those contributions that include an SASE.

Adjustable stop uses a T-slot

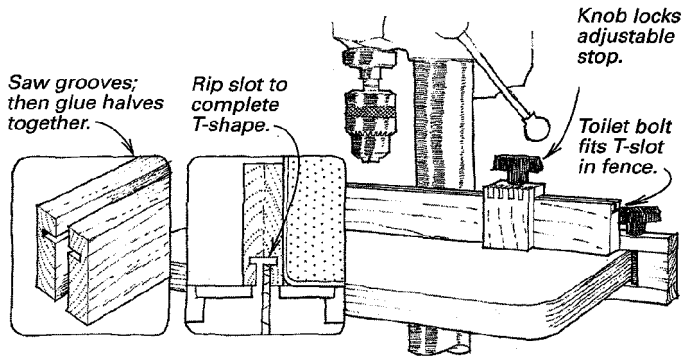

I use this fence stop on a drill press, but it could be adapted easily for another application. The stop is a finger-joined, L-shaped block. It locks to the fence by a knob and a toilet bolt that rides in a T-shaped slot in the top of the fence.

To make the slot, cut kerf-sized grooves into the faces of two fence halves using the tablesaw (see the drawing above). These grooves should be about 1/2 in. from the edge and deep enough to hold half the toilet-bolt head. Glue the two fence halves together, face to face, with a waxed spline in the slot to ensure perfect registration. Now saw into the edge of the fence to complete the T-slot. Center the slot, and size it to fit the shank of the toilet bolt.

—Arthur W. Griggs, Glencoe, Ill.

Vise-Grip stop block is quick and simple

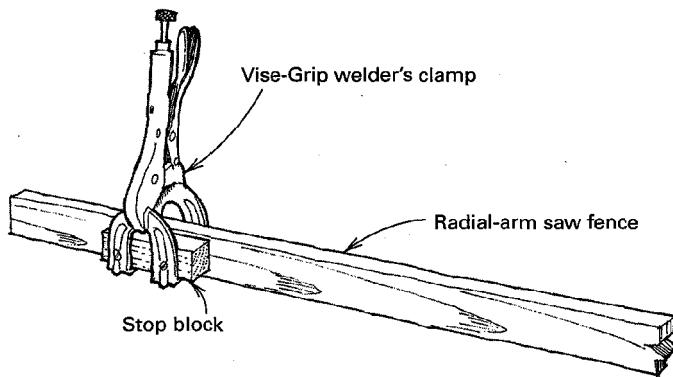

The stop block I use on my radial-arm saw fence is a Vise-Grip welder's clamp. Glue or screw a hardwood block to the L-shaped arms of the clamp. Then adjust the jaw gap until the cam action locks the device to the fence.

—K. O. Brown, Bessemer, Mich.

Quick tip: When storing nails or screws in sealed containers, add some rice to absorb moisture.

—Gary Gene Gautier, Surbiton, Surrey, England

Padded grip improves mallet-handle comfort

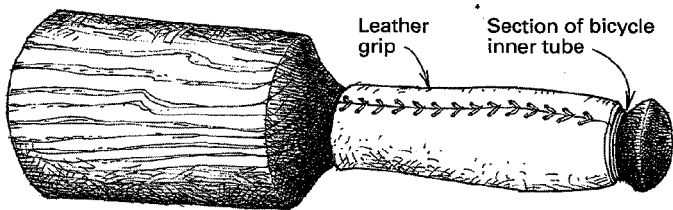

To improve the comfort of a wooden mallet, pad the handle with rubber, and cover it with leather. Cut a section of bicycle inner tube, and stretch it over the handle. Then cut the leather

covering to shape by trial and error. Leave a 1/4-in. gap where the edges meet. Punch rows of matching holes down each side of the joint, dampen the leather and, using waxed cord, lace the leather onto the padded handle like a boot.

—Tom Riley, Baltimore, Md.

Saw fence accurately positions crown molding

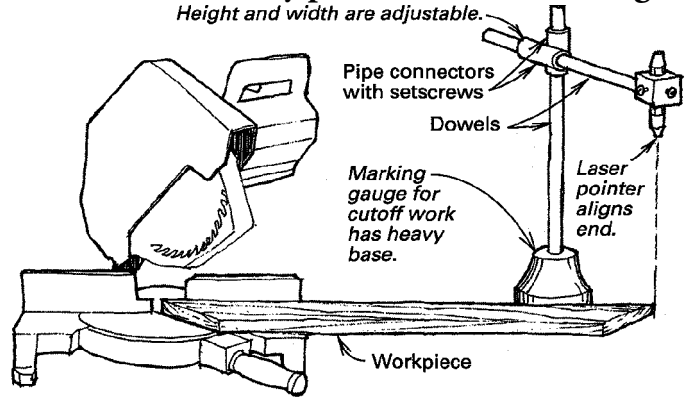

Making tight-fitting, precise joints on crown molding is a time-consuming and fussy task at best. The tall profile of the moldings combined with the low fence height on most chop saws make it nearly impossible to hold the molding in the correct cutting position. To solve this problem, I first added a taller fence to my saw, which helped considerably but did not eliminate the need for strong finger pressure to hold the alignment. Then I cut the fence's height to match the molding's height. This helped some more. But the last step, the addition of a little lip to the top of the fence, made the real difference. Now, light finger pressure suffices because the force from cutting pushes the molding securely into the fixture. I get accurate joints every time.

—Klaus W. Nielsen, Dunwoody, Ga.

Quick tip: Your lathe's tool rest deserves as much attention as your gouges. File the rest smooth and flat every so often, so your tools don't follow the dips and dents and transfer them to your turning. Rub a piece of paraffin wax along the rest occasionally. It makes the turning tools glide easily.

—Geordie Smith, Ruddell, Sask, Canada

Router-table uses easy toggle-clamp mount

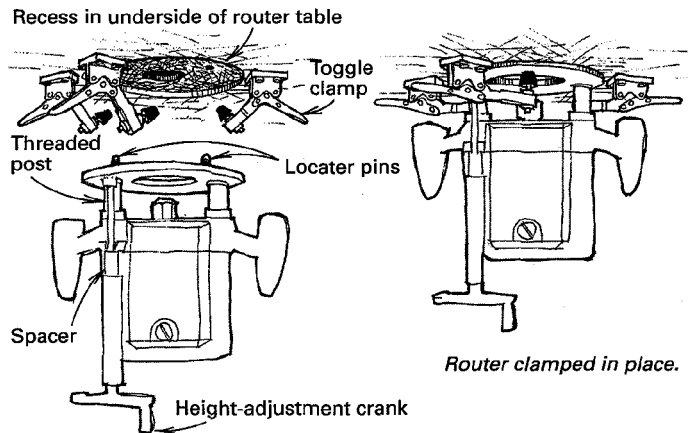

If you've used a router table, you know firsthand the annoyances that go with mounting, dismounting and adjusting the router under the table. So when I redesigned my router table, I wanted a mounting method that was quick, secure and convenient, not only for installing router bits but also for adjusting their cutting depth. The approach I settled on uses three toggle clamps to

hold the router under the table. The setup cost about \$30.

To use this approach, first remove the router subbase and all the miscellaneous hardware attached to the base—wing nuts, stop turret and so on. If you are using a plunge router, buy and install a crank handle to the end of the threaded adjustment column. Now recess the underside of the router table $\frac{1}{4}$ in. deep, and cut a $1\frac{1}{2}$ -in. hole in the center of the recess for the router bit.

Using the subbase mounting-screw locations, install locator pins in the base of the router, and drill mating guide holes in the router table. Make the pins by grinding the heads off machine screws. Screw three or four toggle clamps at convenient, equally spaced locations around the base of the router, and adjust their clamping action to hold the router firmly in place. Toggle clamps are available in several varieties and holding strengths, from 60 lbs. to 1,000 lbs. I'd advise some over-engineering here: for example, 200-lb. clamps with anti-vibration locks and horizontal handles.

Now I can dismantle the router and have it on the tabletop ready for a bit change in about 10 seconds, and I don't have a mounting plate to work around. Mounting takes approximately 20 seconds.
—Arthur Margolese, Santa Rosa, Calif.

Quick tip: Try dipping a flat magnet into your drawer of brads. It's much easier to pluck a single brad from the resulting metal sculpture than from the drawer bottom. When you're through with a project, brush the brads off the magnet and back into the drawer.
—Byron J. Thomas, Tulsa, Okla.

Routing stopped grooves for inlay strips

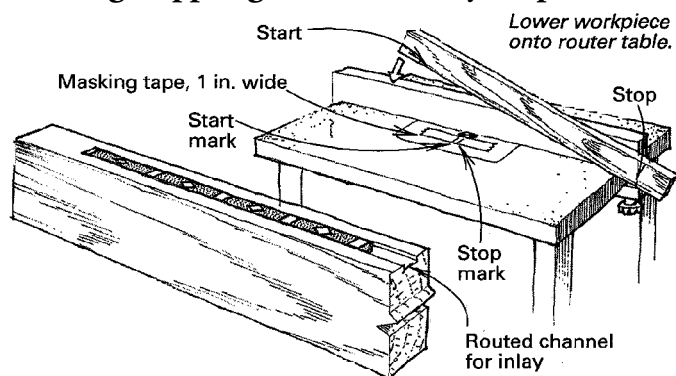

While I was pregnant with our first child, my husband, Marty Jack, and I made a crib. In addition to using the wood of our choice (maple), we wanted to personalize the crib with inlay strips. But we needed to find a place where the inlay would survive a baby's inquisitive fingers and teeth. For safety, we centered the inlays in the top of each drop-side rail under plastic teething protectors.

Choosing the inlay pattern from The Woodworkers' Store (21801 Industrial Blvd., Rogers, Minn. 55374-9514; 800-279-4441), we bought strips for the two rails, each $\frac{1}{4}$ in. wide by 36 in. long, plus extra length so the pattern would match at the ends. To create stopped grooves for the inlay strips, Marty used his router table, setting the depth of cut to 0.075 in., half again the $\frac{1}{20}$ in. thickness of the inlay. The extra depth kept the strips (with glue) below the top of the rail, which let us buff out the finish without damaging the inlays.

To show where to start and stop each cut, he laid a strip of masking tape on the table in front of the router bit. Setting a square against the fence and against the edge of the router bit, he marked off both sides of the $\frac{1}{4}$ -in. straight-cutting bit. Then he made corresponding start and stop marks on the side of the two top rails (see the drawing). The marks allowed him to see where the bit's edges were while the work was covering them.

To start each cut, Marty plunged the rail onto the router bit with the workpiece start mark in line with the tape's leading bit mark. He guided the work along the fence and then ended the cut by lifting the piece off when the tape's trailing mark and the rail's stop mark aligned. —Barbara Bazemore, Merrimack, N.H.

Compressed tenon fits tighter in socket

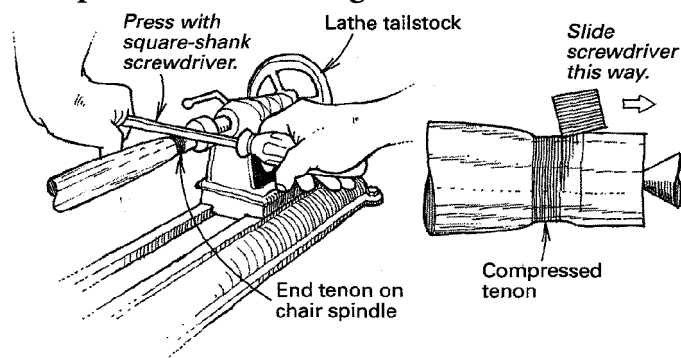

With the technique shown in the drawing above, I can get a tight-fitting socket joint without having to drive in a wedge. The secret is to compress the tenon while it's still on the lathe. Start by turning the tenon about $\frac{1}{32}$ in. oversize. Then, with the leg still turning in the lathe, use a large square-shaft screwdriver or similar tool to compress the fibers of the tenon. Push down hard on both ends of the tool while slowly moving it along the length of the tenon. This will compress the tenon so that it can slip easily into the socket.

When assembling the joint, spread glue in the hole, put glue on the compressed tenon and immediately insert it into the hole. Within 15 seconds, the wood will expand and lock the joint tighter than if you had wedged it.

—Tim Hanson, Tomahawk, Wis.

User-friendly sanding blocks

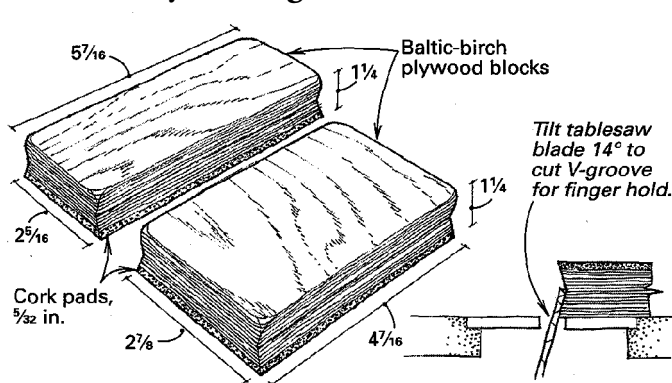

To make hand-sanding less tiring, our class at Anderson Ranch Arts Center analyzed and redesigned the common sanding block. After experimenting with a variety of materials and thicknesses, the consensus was that a relatively thick (1 in. to $1\frac{1}{4}$ in.) block laminated from hefty Finply or Baltic-birch plywood, is the most comfortable. We glued $\frac{5}{32}$ -in.-thick sheet cork, available from any building-supply store, to one side of slightly oversized blanks. Then we trimmed the blocks with the cork-side up to reduce tearout.

Opinion was split on whether the blocks should be narrow or wide. So to satisfy everyone's ergonomic needs, we came up with the two sizes shown in the drawing above. Each one uses a one-quarter sheet of sandpaper. After the blocks were cut to size, we sliced shallow V-grooves (finger holds) in both long edges of the blocks on the tablesaw. Finally, we rounded

the corners and then lightly sanded all the surfaces.

Our prototypes were reviewed by Nicole Vavuris, a safety engineer for the city of San Francisco. He said that the stress in the wrists caused by hand-sanding would be lessened by using these blocks, which encourage you to sand with the heel of your hand in a "power grip." Always avoid a fingertip grip.

—John and Carolyn Crew-Sheridan, San Francisco, Calif.
(and the class at Anderson Ranch, Colorado)

Dust-collecting sanding station

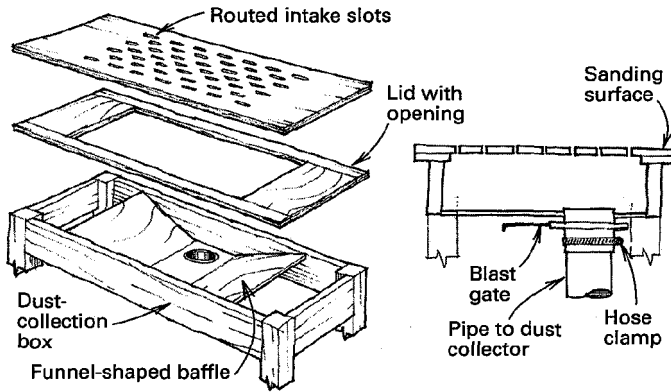

This sanding station, which I installed as an extension to my bench, has proved useful for sanding, routing and biscuiting. It pulls in most of the fine dust created by these operations. I brush any dust that remains over the slots and watch it disappear.

To build the sanding station, rout a number of short slots in $\frac{3}{4}$ -in. material. Then build up the underside of the top by lami-

nating in an extra $\frac{3}{4}$ -in. lid, leaving open the area where the collection box fits in. Attach a scrap-plywood collection box to the bottom, and add a blast gate and pipe to your dust-collection system.

—John Weidner, San Francisco, Calif.

Add a support to rip thin plywood

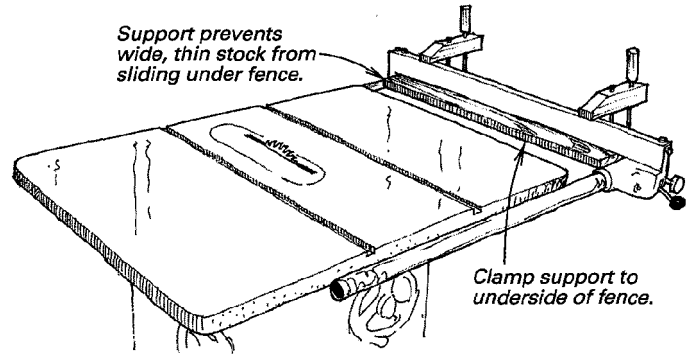

When ripping wide panels from thin sheet stock or plastic laminate, the edge next to the fence has a tendency to slip under the fence, which can be dangerous. To remedy this situation, clamp a piece of scrap under the fence, as shown.

—Edmond Valade, Goffstown, N.H.

Methods of Work buys readers' tips, jigs and tricks. Send details, sketches (we'll redraw them) and photos to Methods, Fine Woodworking PO Box 5506, Newtown, Conn. 06470-5506. We'll return only those contributions that include an SASE.

EDITOR'S NOTE: April's "Methods of Work" column (issue #111, p. 10) shows an incorrect drawing and headline with Klaus Nielsen's method for using a high, lipped fence for cutting crown molding on a chop saw. The drawing actually showed Taylor Fain's laser-pointer cutoff gauge. Here are the corrected methods and drawings:

Saw fence accurately positions crown molding

Auxiliary fence guides accurate compound-miter cuts on crown molding.

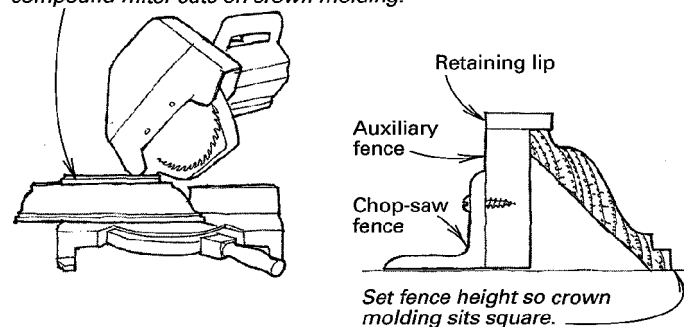

Making tight-fitting, precise joints on crown molding is a time-consuming and fussy task at best. The tall profile of the moldings combined with the low fence height on most chop saws make it nearly impossible to hold the molding in the correct cutting position. To solve this problem, I first added a taller fence to my saw, which helped considerably but did not eliminate the need for strong finger pressure to hold the alignment. Then I cut the fence's height to match the molding's height. This helped some more. But the last step, the addition of a little lip to the top of the fence, made the real difference. Now, light finger pressure suffices because the force from cutting pushes the molding securely into the fixture. I get accurate joints every time.

—Klaus W. Nielsen, Dunwoody, Ga.

Laser pointer makes an accurate cutoff gauge

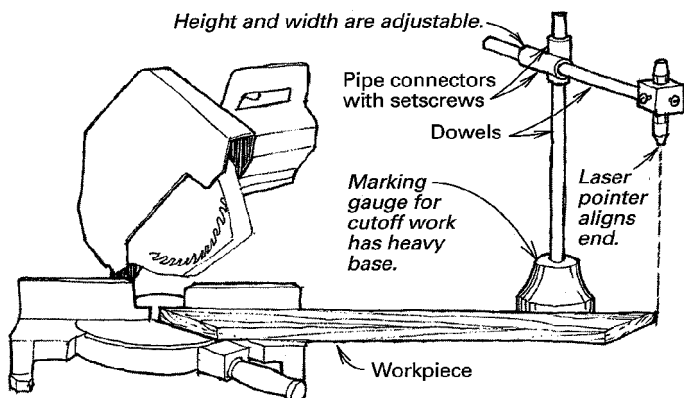

Here's a gadget that lets you set a reference point anywhere in your shop for extremely accurate measuring. This pointer is great for cutoff work when making lots of duplicate pieces. It uses a Radio Shack laser mounted on a homemade stand. Except for the laser pointer, which will set you back about \$50, you can make the rest of the gauge from stuff around the shop.

The spot projected by the laser pointer is about 1/8 in. dia. and remains so over 65 ft. Using the edge of the spot to position a piece, I obtain more than adequate accuracy. To use the gauge for making repetitive cuts, I measure and position the first piece in the saw and make the cut. Then I set up the gauge so that the laser touches the end of the piece. After that, I align each piece so that the tip hits the laser pointer and then I cut.

More expensive commercial laser gauges used in the furniture industry are available. But this version, though not cheap, costs much less and works just as well.—Taylor Fain, Clemmons, N.C.

Quick tip: If you're tired of using lung power or keeping a compressor running just to blow sawdust off a cutting line, use a rubber ear syringe. The molded rubber bulbs are about 2½ in. dia. and have pointed nozzles. The syringes are available at most drug stores.
—E.S. Martin, Montrose, Ala.

Plate joinery with a router

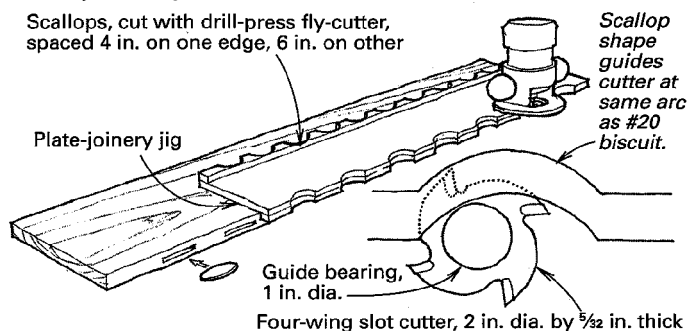

Richard Fryklund's budget-conscious plate-joinery jig (*FWW* #75, p. 12) inspired the jig shown above. This jig incorporates a series of scallops along both edges of a piece of Baltic-birch plywood to eliminate the tedious clamping and unclamping required when cutting a series of biscuit slots.

To construct the jig, start with a piece of plywood about 10½ in. wide and 42 in. long. Using a fly-cutter in a drill press and a fence, bore a series of equally spaced 3-in.-dia. holes, just touching each edge. I spaced the scallops 4 in. apart on one edge and 6 in. apart on the other to provide a variety of slot spacings. Now glue and clamp ¼-in. by 1-in. strips of plywood along the diameter of each line of holes on opposing faces of the jig. When the glue has cured, rip equal amounts off each side, leaving 5/8-in.-deep scallops and a fence on the edges. This size scallop, when used with a 2-in.-dia. wing cutter and a 1-in.-dia. guide bushing, will produce an arc that will cut a semicircular slot matching a #20 biscuit size.

To position the jig, line up the centerline of the jig with a centerline scribed on the edge of the workpiece.

—R. Brucken, Martinez, Calif.

Pinpointing router-mount and insert locations

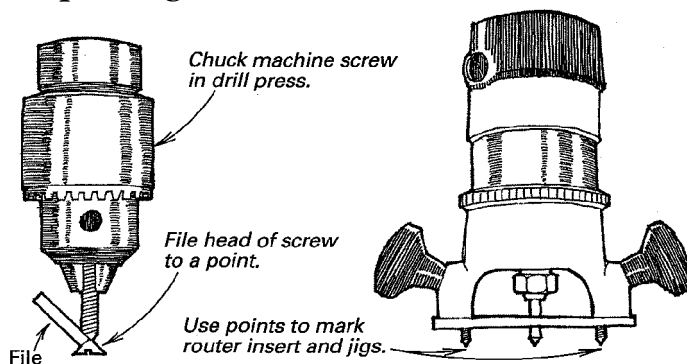

Here's a simple method for marking the drill holes for mounting a router to a jig or router-table insert. For each threaded mounting hole in the router base, purchase a 1½-in.-long machine screw. Install each machine screw in a drill press with the screw head down. Set the drill press to a slow speed, and use the edge of a flat file to remove the head of the screw and create a centered point. Use this same process to make an end mill

for the collet using the unthreaded section of a 1/4-in. bolt. Screw in the threaded inserts, points down, and chuck the end mill into the collet, adjusting its height to match that of the threaded inserts. Now carefully place your router on the router-table insert, and press down. The collet and all the threaded inserts will leave a mark pinpointing the exact drill sites.

—Mike Mullin, Manhattan Beach, Calif.

Fence stop locks with a cam lever

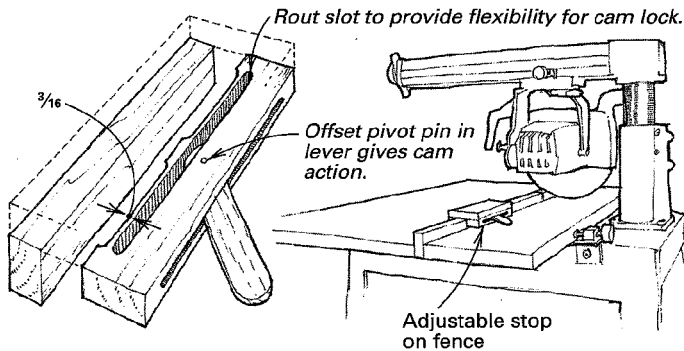

When I decided to make a fence stop for my cutoff saw, I remembered Dave Flager's (*FWW* #71). I used Flager's concept, but I revised the cam-locking action to better fit a fence stop.

The stop consists of three parts assembled into a U-shape. The only tricky part is the piece that holds the cam. I bandsawed the interior edge into a shape with three bearing surfaces, as shown. Then I cut a slot through the piece to give the middle of the stop the flexibility it needs to move away from the cam and lock against the fence. There are several ways to do this. You could plunge your tablesaw blade through the piece. But for safety, it's better to use a router. Leave about 3/16 in. of material. To assemble, clamp all the parts temporarily to the fence and mark positions. Screw the three parts together, and trim any overhang from the front or back. To complete the stop, install the cam. Fine-tune its position while the stop is on the fence. Then, when you have everything right, drill and install the pivot pin. I used a brazing rod for this.

—William A. Baker, Harpswell, Maine

Quick tip: To fit a tanged tool to a handle, drill a hole in the handle, heat the tool and push it into the hole. The tool will burn itself into the hole, making a solid, tight fit. No epoxy is required.

—Bob Dietz, Arroyo Grande, Calif.

Recycling broken golf-club shafts

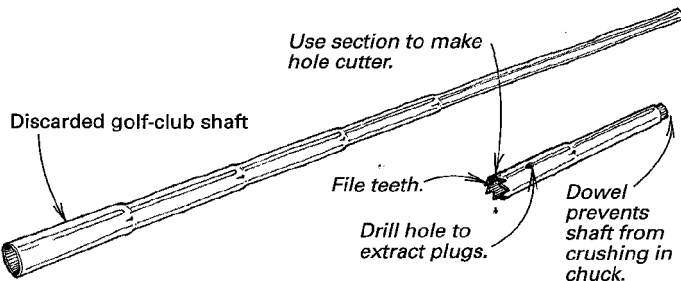

Frequently, you can find stepped-down-diameter club shafts that have broken off at the head in golf-shop trash bins. These shafts are made from hardened, high-quality steel and can easily be recycled into useful shop tools. For example, to make a punch, just cut a section off the handle with a pipe cutter, and grind a bevel on the outside of the bottom end. Or to make a small-diameter hole saw, file several small teeth around the circumference, and then set alternate teeth with a pair of sharp

nose pliers. To avoid crushing the thin wall shaft with the drill-press chuck, drive a tapered dowel in the chucked end.

—G. Woody Ferguson, Norcross, Ga.

Quick tip: Protect your work from pipe clamp bruises by attaching scraps of leather to the clamps with spray adhesive. If you don't have an old belt, scraps of shoe sole leather can be obtained at little or no cost by visiting your neighborhood shoe repair store.

—R. Tara, Willow Grove, Pa.

Attaching bed rails with shelf brackets

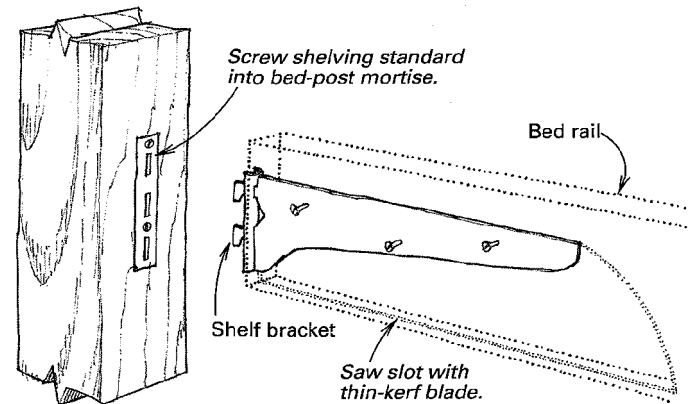

Ready-made bed-rail fasteners are expensive, so I designed this alternative using common shelf brackets. The brackets are designed for cantilevered book loads and aren't very stiff laterally. But, when captured snugly in a bed rail, as shown, they are significantly more rigid. Even so, you should not use this setup for bunk beds. It's really best for situations where you need a knockdown bed frame.

Start by fitting the shelving bracket into a sawkerf in the underside of the end of the bed rail. Most brackets are about the thickness of a thin-kerf sawblade and will fit snugly into the kerf. Align the end of the bracket to the end of the rail, and then pin in place with screws from the inside of the rail. Saw off a short length of the shelving standard (track), and screw it into a shallow mortise routed into the bed post.

The rail draws tightly to the post once the bracket is pushed into position. Because each rail attaches to the end post with two hooks, the bed cannot rock. A light tap on the underside of the rail disassembles the bed, and there are no nuts and bolts to lose during transport.

—Rick Officer, West Brunswick, Victoria, Australia

Strop gives mirror finish to cutting edges

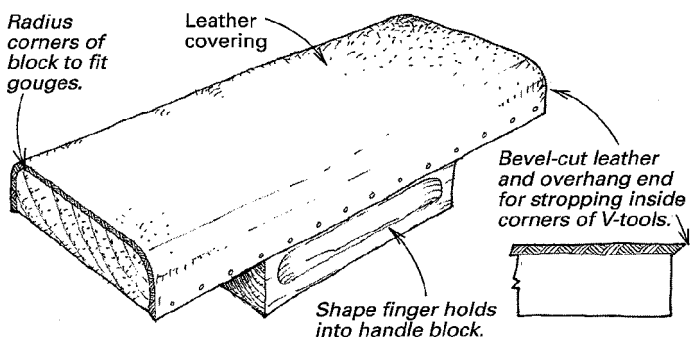

For a really fine cutting edge, tools should be honed on a leather strop. To make one, cut a piece of scrap softwood about 3 1/2 in. by 7 in. Plane a small radius along one side and a larger radius along the other to fit the curve of your gouges. Cut a piece of

smooth-surfaced leather to fit around the block with a bit of overhang off the end. Trim one end of the leather to a 45° bevel with a sharp knife. Glue the leather to the block, tack it along the bottom of the edges and attach a handle block to the bottom of the strop. Charge the strop by rubbing aluminum-oxide (fine abrasive) compound or chrome polish into the leather.

To use, always draw the tool's back across the strop, never push forward. Work the inside of gouges on the rounded edges and V-tools on the beveled overhang. The strop will put a mirror finish on your cutting edges, and remove even the smallest wire. Clean the leather with saddle soap every few months, and reapply the abrasive.

—Tom Riley, Baltimore, Md.

Flexible duct solves awkward dust hookups

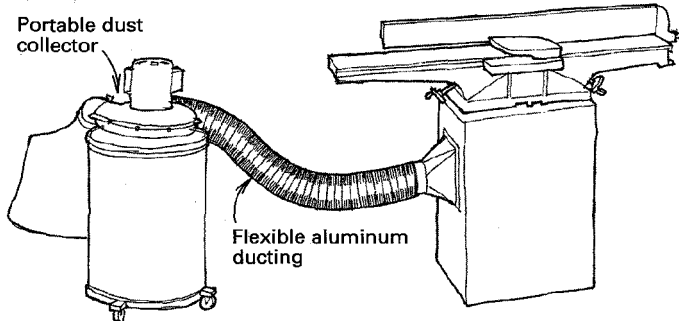

My dust collector is mounted on a dolly, which I roll around the shop, so I can hook it up to whichever machine I'm using. Flexible hose works well in this situation. I use flexible aluminum ducting, made by Dundas Jafine (available through your local

building supply dealer), which is spiral-wound from corrugated aluminum. The ducting comes in diameters from 3 in. to 14 in. Besides being flexible, it is much more durable than plastic film-over-wire drier duct. It also doesn't collapse under suction and is easy to cut to length.

Some flow capacity is lost because of the rough texture of this material, so I wouldn't run duct work for an entire shop from this product. But wherever you have a portable collector or need severe bends, it's ideal.

—Guy Lautard, West Vancouver, B.C., Canada

Picture-frame marking fixture is adjustable

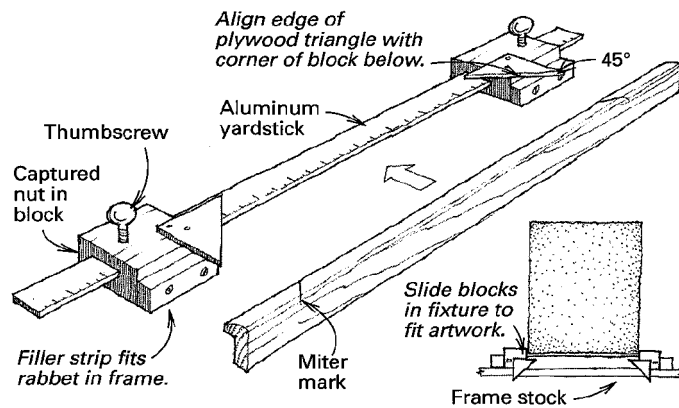

When I had to make a large number of hardwood picture frames, I designed this fixture to help me mark out miter lines on the frame stock. The fixture, which adjusts to fit the artwork

you're framing, consists of an aluminum yardstick and two shop-built sliding blocks. Each is equipped with a thumbscrew for locking a 45° thin-plywood triangle to mark the miters and a replaceable filler strip cut to fit the rabbet in the frame. It's important to align the edge of the triangle over the corner of the block below for proper registration.

To use, adjust the sliding blocks to touch each edge of the artwork, and lock the blocks into position with the thumbscrews. Place the frame stock in the jig, so the rabbet fits over the filler strip, and adjust the stock position until you have the grain pattern you want. Now mark the miter line on both ends of the frame by scribing against the triangle.

—Warren Bender, Medford, N.Y.

Folding infeed table quickly dismounts from saw

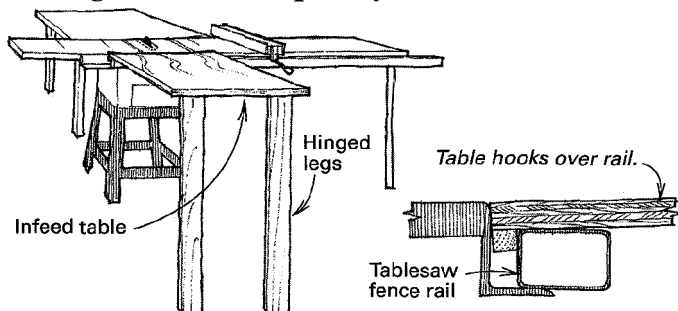

Because I'm older and work alone, I need all the help I can get when feeding big, clumsy sheets of plywood into my tablesaw. But I just don't have room in my cramped shop for another table. So I designed this folding table, about 2 ft. wide and 4 ft.

long, with hinged legs on one end and a ledge on the other end, which hooks over the rip-fence rail. The legs are a little longer than needed for a level table. The slightly upward slant seems to help hold the table in place. When I'm through ripping, I fold up the legs and lean the table against the wall.

—Cliff Nathan, Studio City, Calif.

Hanging tools with a toggle

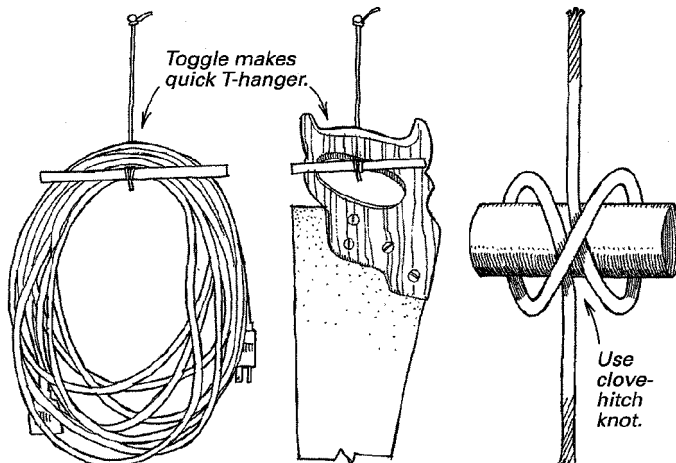

This simple hanging system, used by seamen to hang rope lines in lockers, is handy in the woodshop. Tie a short length of cord to a dowel using a clove hitch, and fasten the cord to the wall with a nail or screw eye. To use, pass the tethered dowel, called a toggle, through the handle of the tool. Various sized toggles

can be used for different tools. This system works especially well for handsaws and coiled extension cords.

—*Sherwood Schwartz, Palm Harbor, Fla.*

Dovetail marking template

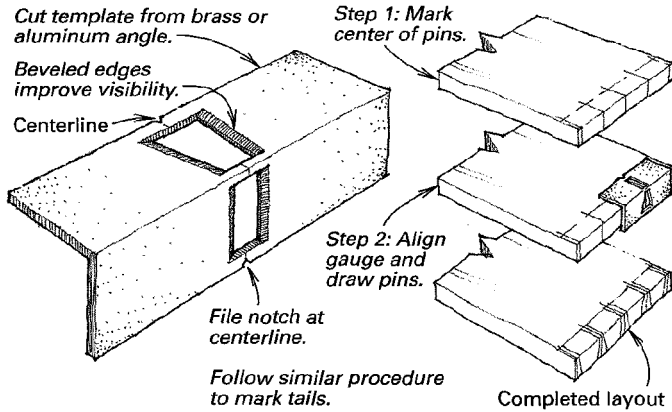

This template simplifies the process of marking dovetails. Start with a 5-in. length of 1 1/2-in. by 1 1/2-in. brass or aluminum angle. Square up the inside corner of the angle with a file. Mark the centerline of the pin, and file two notches, one on each edge. Cut and file two openings, one angled for the pin profile and one straight for the base of the pin. Leave a bridge between the two openings for rigidity. The two openings should be exactly the same width at their base where they touch the bridge.

—*Frank Norman, South Perth, Western Australia, Australia*

Substituting eyebolts for knobs

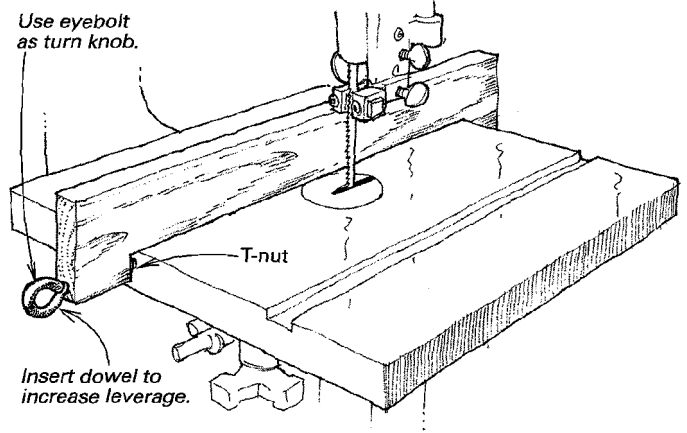

When you need some serious tightening, wood components just won't take the torque. Whenever possible, I substitute common threaded eyebolts for stud-type knobs and thumbscrews. Eyebolts are widely available in many sizes, lengths and thread pitches. And for maximum tightening, you can insert a length of dowel for a cross handle to exert as much force as you need.

—*Jeff Gyving, Point Arena, Calif.*

Methods of Work buys readers' tips, jigs and tricks. Send details, sketches (we'll redraw them) and photos to *Methods*, Fine Woodworking PO Box 5506, Newtown, Conn. 06470-5506. We'll return only those contributions that include an SASE.

Producing wavy shapes on the bandsaw

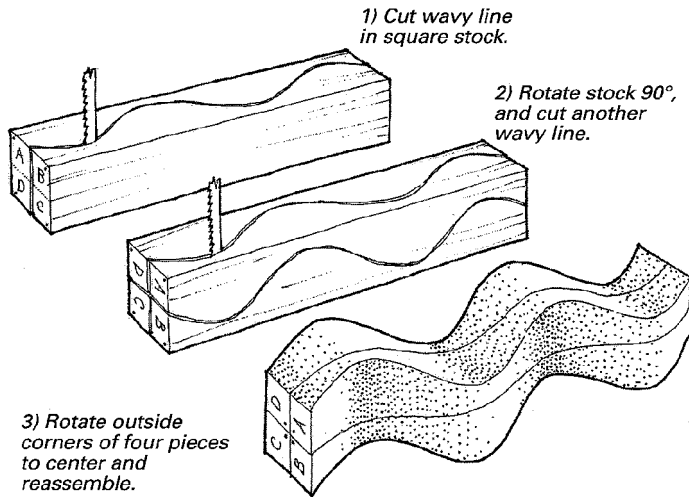

With this bandsaw technique, you can make lots of wavy shapes to use for lampposts, canes, balusters and newel posts. Start with a length of perfectly square stock. Cut the workpiece in two with a wavy line. Temporarily reconnect the two halves, turn the workpiece 90° and cut the workpiece again with a wavy line. Now rotate each piece 180°. Labeling the ends of the pieces will help with this step.

When you reassemble the pieces correctly, the four outside corners will be together at the center. The outer form of the stick will be a continuous undulating curve. Glue the four pieces together, and clean up the curves with a drum sander.

To get a square hole through the center of the piece (to allow for a lamp cord, for example), chamfer each of the four corners of the workpiece before bandsawing. I learned this technique from Rick Shirley of Kansas City, Mo.

—Kirt Kirkpatrick, Albuquerque, N.M.

Quick tip: Here is a nontoxic way to clean pitch and other residue from a sawblade. Sprinkle baking soda on the blade, spray with water and let the mixture sit for 15 minutes. Then scrub the teeth with an old toothbrush to remove the loosened residue.

—Mark Sloan, Farmington, Conn.

Feeler gauge for inside measurements

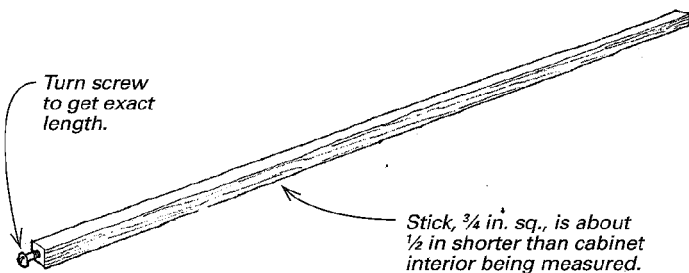

Here is a simple, accurate method for taking those awkward inside measurements, the kind you need to fit a shelf in a cabinet, for example.

Cut a scrap of 3/4-in.-sq. wood about 1/2 in. shorter in length than the inside dimension of the cabinet. Drive a round-head screw into the end grain of one end. You now have a feeler

gauge, adjustable with a screwdriver to the exact length needed. Once you have the correct length, there is no need to measure—just set the cut length directly from the gauge.

—Gary P. Westmoreland, Apple Valley, Calif.

Preserving finish with a wine vacuum

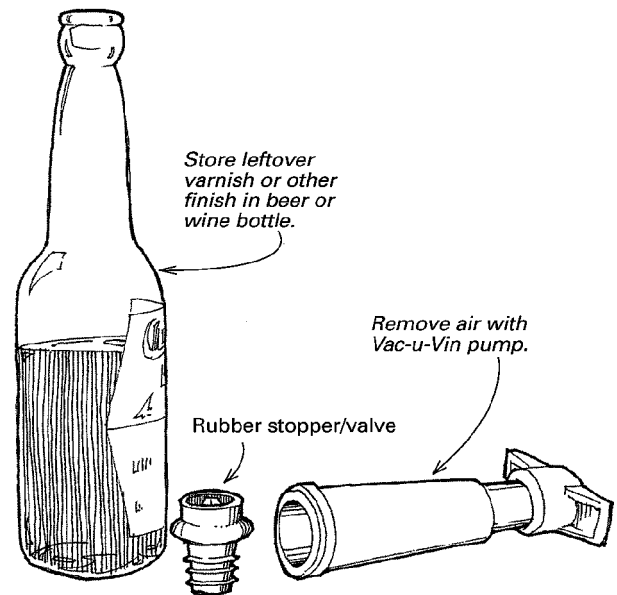

The traditional solution for keeping small leftover quantities of varnish or tung oil from skimming is to decant the finish to a smaller container to minimize the air space. Another approach, which is just as effective, is to transfer the varnish to a wine or beer bottle and apply a vacuum. Systems for evacuating the air from a wine bottle, such as Vac-u-Vin, cost less than \$15 and combine a rubber stopper/valve with a hand pump.

Before using the pump, clean and rinse the bottle, and put it in a microwave for a minute to dry it out. Transfer the leftover varnish to the bottle, insert the stopper, give it eight to 10 strokes, and then label and date the bottle.

—Dave Robinson, Ann Arbor, Mich.

Sizing round tenons on the lathe

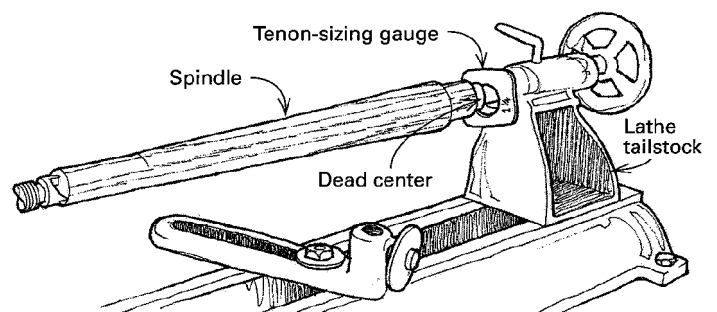

The turned legs on the stools I have been building require an exact 1 1/4-in.-dia. tenon on one end. The usual approach to sizing tenons is to turn them slightly oversize using a caliper gauge. Tenons are then trimmed to size gradually by dismounting the stock from the lathe and testing the tenon in the hole until it fits.

To streamline this routine, I drill a hole in a slip of thin ply-

wood with the same Forstner bit I use to drill the mortise. Then, before mounting the workpiece, I hang this slip in the gap between the lathe's tailstock and dead center. The slip hangs there out of the way until I need to check the tenon size by stopping the lathe and trying the gauge on the tenon. There's no need to dismount the stock. —Warren W. Miller, Slate College, Pa.

Biscuit slots accommodate wood movement

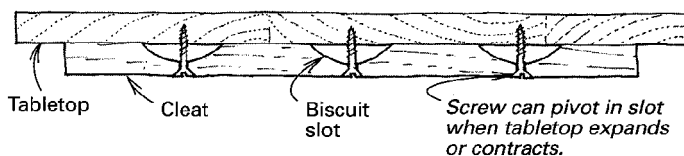

Use your biscuit joiner to make concealed screw slots that will allow wood movement. The screws will swing in the slots allowing a solid-wood tabletop or panel to expand or contract with humidity changes. —Davis G. Durham Jr., Landenberg, Pa.

Quick tip: To prevent clamp slippage -when clamping up curved workpieces, attach a small piece of two-sided adhesive mounting tape under the clamp swivel. The tape won't slip, and its foam core will serve as a cushion to protect your project.

—Dick Dom, Oelwein, Ia.

Use a calculator to figure compound angles

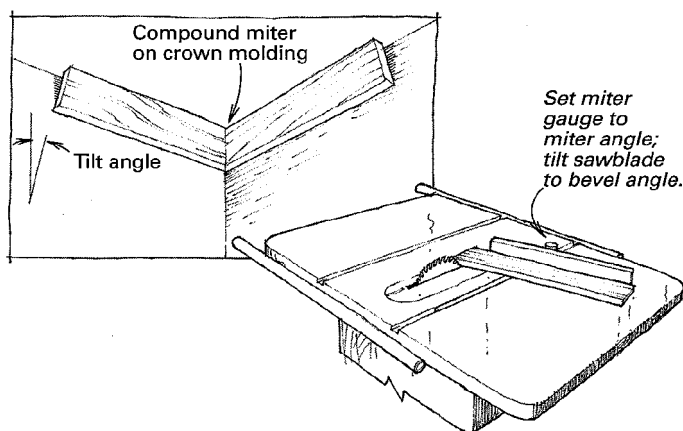

There are two ways to cut the compound miters on crown molding accurately. One way is to place the molding in the miter saw at exactly the same tilt angle as it will be when installed. With this method, you set the saw's miter gauge at 45°, and leave the blade tilt at 90°. Because most saws have a limited throat depth, this approach isn't practical for wide molding.

Another way is to lay the molding flat on its back and cut a compound miter. A compound miter requires you to set the saw's bevel and miter angles to odd calculated values that depend on the tilt of the molding away from vertical. If you have a scientific calculator you can calculate both angles easily using the formulas below:

$$\text{Miter angle} = \tan^{-1}(\sin \text{ tilt})$$

$$\text{Bevel angle} = \tan^{-1}(\sin \text{ tilt} / \tan \text{ tilt})$$

Don't be scared by the trigonometric terms. If you own a Texas Instrument calculator or one of a similar style, you can plug in the functions and numbers directly using the keys (they should be marked pretty much the same as they appear in the

formulas). Calculate the values in the parentheses, and store them. Then apply the rest of the function to them to get the angles you need. —LB. Magnusson, Paradise, Calif.

Guide for routing dados

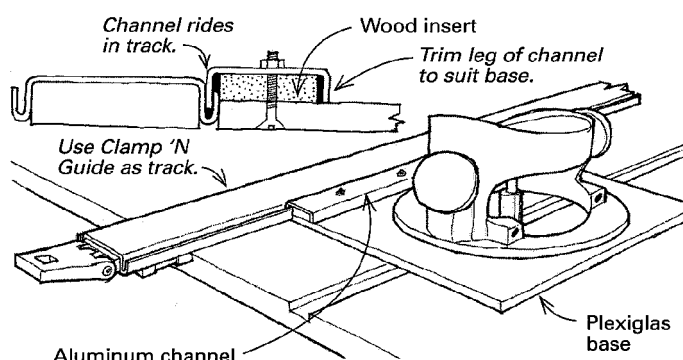

I had been looking for an easy-to-build jig to hold my router against a Clamp 'N Tool Guide (Griset Industries, Inc., P.O. Box 10114, Santa Ana, GA 92711; 800-662-2892). So when I read Skip Lauderbaugh's article, "Compact Tool Makes Dados a Snap" (*Fine Woodworking* #110, p. 86), the lights came on. Though I did not have the space for Skip's wall-hung jig, I saw within it the answer to my router-guiding problem.

That evening, I went out to the shop and gathered an aluminum channel that fit the Clamp 'N Tool Guide quite well and a leftover piece of Plexiglas. I cut off a 14-in. length of the channel and trimmed one leg, as shown. Then I milled a piece of oak to fit between the plastic and the channel. I assembled the parts temporarily with double-faced tape to keep everything in registration. Then I added three flat-head screws to hold things together permanently. In just a couple of hours, I was ready to cut my first dado.

Later, I realized that this idea would work equally well for a circular saw. So I made a similar fixture for my circular saw, substituting 1/4-in.-thick Masonite for the Plexiglas base.

—Jack Zabel, Cedar Falls, Ia.

Using blocks to duplicate hole patterns

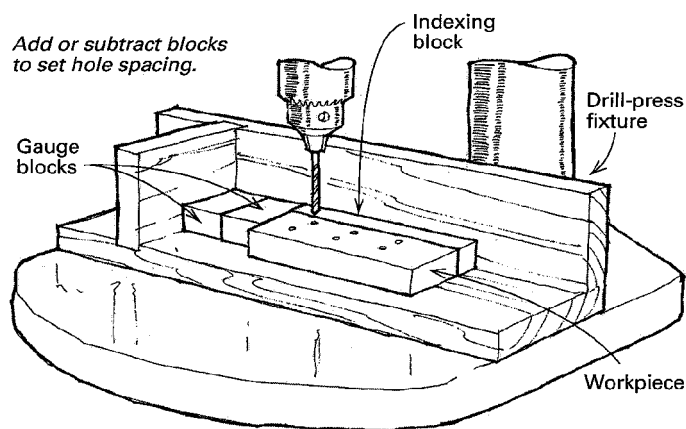

Here's an exact and reproducible way to drill rows of evenly spaced holes. The technique uses a drill press and a fixture that combines indexing blocks, a fence and gauge blocks.

Cut the indexing blocks the same width as the distance be-

tween the rows of holes you want. Place a block between the fence and your work, align the drill bit with the first hole and then drill the holes in series, removing and adding the gauge blocks as you go. Be sure to blow away any sawdust, which would reduce the accuracy.

—Michel Theriault, Ottawa, Ont, Canada

Quick tip: When you need to enlarge a tablesaw dado by just a bit, tape a piece of paper to the fence, and run the piece through again. Different-thickness papers will vary the adjustment in the dado. The results are much more accurate than trying to move the fence.

—Jack Kegley, Charlottesville, Va.

Modified dovetail saw works on the pull stroke

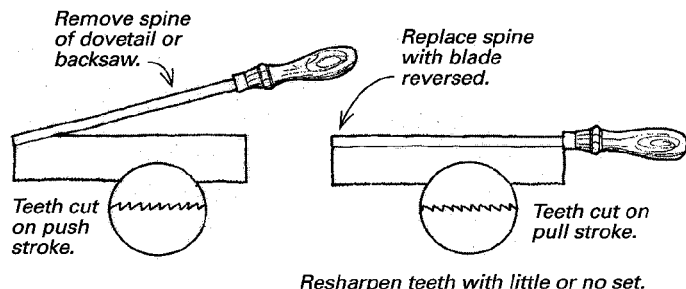

Take an ordinary fine-toothed dovetail saw, and clamp it in a vise close to its spine. Gently tap the handle up to remove the blade. Then reverse the handle, so the blade cuts on the pull stroke. Tap the spine back on the blade, and clamp the spine between the vise jaws. Sharpen as usual, but with little or no set. The result is not an authentic Japanese saw, but it is similar to a Chinese coffin-maker's saw and a lot easier to sharpen.

—Joe Santapau, Yardley, Pa.

Quick fence-reset fixture for the tablesaw

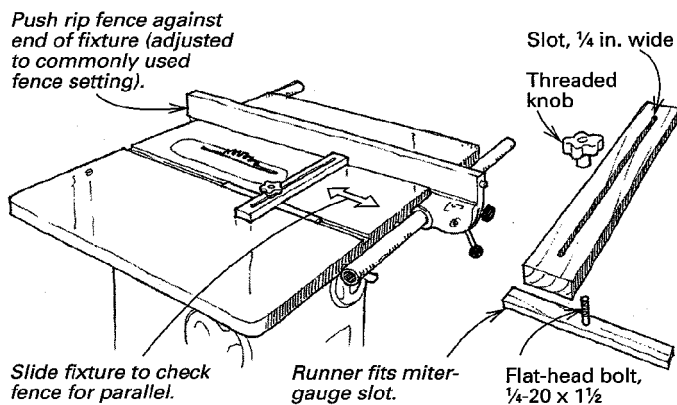

Forty-five years ago, I worked in a large shop where I cut out parts for store cases, 50 or so per tablesaw setup. In some instances, we had to mill special orders to slightly different dimensions and then return to the original saw settings. This required tedious machine changeovers, particularly setting and resetting the fence. In my home shop last year, I belatedly came up with an idea that would have been very valuable to me nearly a half-century earlier.

It is a very simple fixture, consisting of two hardwood bars that form an adjustable cross. I sized the bottom bar to fit the table-saw miter-gauge slot and routed a slot in the top bar. It slides

back and forth over a bolt and can be locked in place with a knob. To use the fixture, I push it into the miter-gauge slot, move the upper bar against the rip fence and tighten the knob. It's a good idea to check fore and aft on the fence to make sure it is parallel to the blade. To reset the fence to the original setting, I just pop the jig into place and slide and lock the rip fence against it.

—George S. Graham, Branford, Fla.

Strength table for wooden threads

I have noticed that most authors in *Fine Woodworking* will chose a T-nut or metal insert when they need threads in wooden parts. There are situations, however, where installing a T-nut is awkward, or the strength of metal threads is not needed. In these situations, I just tap the threads directly into the wood. Any reasonably sharp metal-cutting tap is satisfactory. To provide a snug thread, I like to use a tap drill nearer to the root diameter of the thread, instead of those used for tapping metals.

Thread Size	Tap (metal)	Tap (wood)	Ultimate load (lbs.)
8-32	#29	#31	130
10-24	#25	#29	150
1/4-20	#7	#11	200
3/16-18	1/4	5/16	240
3/8-16	3/16	19/64	290

The table above shows the tap drill I use and the strength for threads tapped into wood. The ultimate load values have been calculated in pounds for a 1/2-in.-long thread in black cherry, using a nominal shear strength of 500 lbs. per sq. in. parallel to the grain. Shear strength perpendicular to the grain is greater than parallel, so this table gives a good idea of minimum strengths.

—Clyde R Seitz, East Aurora, N.Y.

Quick tip: Remove the maker's label on your tape measure, and glue a circle of plastic laminate in its place with contact cement. You will always have something to write on.

—Kurt Schabell, Rockford, Ill.

Oscillating spindle sander uses a drill press

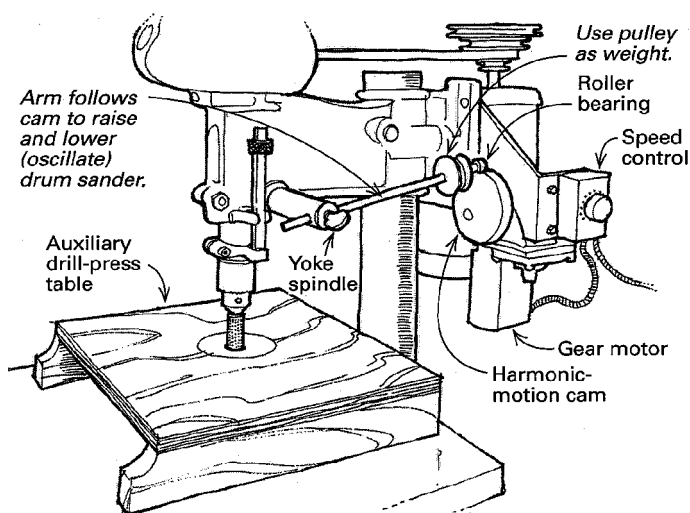

The oscillating spindle-sander attachment for a drill press described in *FWW* #109 appears to be a good substitute for a benchtop sander. I built a similar, less-expensive version that

I've been using for more than 20 years. The attachment uses a gear motor to drive a harmonic-motion cam (a circular disc rotating off center), which raises and lowers the quill by means of a follower arm. I made the cam from 1/2-in.-thick Garolite, a dense thermoset plastic, which looks like tempered Masonite. Aluminum or even hardwood could be substituted. The follower is a steel rod that fits in the feed-yoke hole in the drill press. It is fitted with a roller bearing that rides the cam. Sandwich the bearing between thin brass washers, and hold it in place with a slotted-head machine screw. Fasten a weight to the rod (I used a cast-iron pulley) to counteract the spindle-return spring so that the follower rides firmly against the cam as it revolves.

My gear motor is a forerunner of the current Dayton model 2Z803, 1/4 hp, 100 rpm. I reduce the motor to a workable rpm with a speed control. Other slow-speed or variable-speed motors could be used. No matter what motor is used, the only ingenuity required in this setup is in devising a mount for the motor that puts the cam in the right position for the follower arm.

—William E. Slaby, Royal Oak, Mich.

Holding multiples with hot glue

When I want to cut several identical pieces with my bandsaw, I secure the laminations with a crisscross of hot glue at the corners or across the ends. This is much quicker and cleaner than brads or double-faced tape. If the glue residue isn't removed in the cutting, just scrape it off.—Greg Byington, Brownsburg, Ind. and Carroll Caddel, Plano, Texas

Quick tip: In the winter, it is difficult and costly to keep our shop above 70 °F for proper setting of glue. So we drape electric

blankets over the work and then add a layer of regular blankets for insulation. While the blanket is on, we make sure the assembly is not left unattended.

—Michael Sykes, Raleigh, N. C.

Laminate closes gap under the rip fence

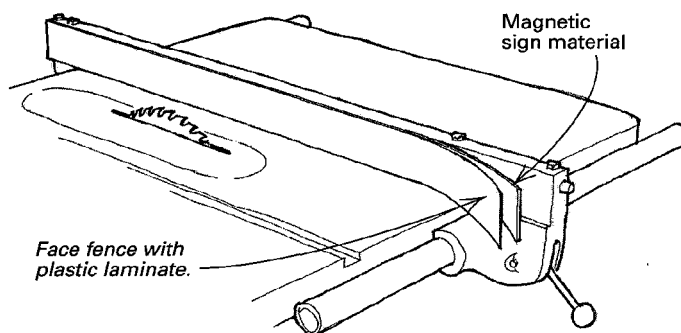

To prevent thin stock and plastic laminate from slipping under a rip fence, buy a scrap of magnetic sign material, and use spray glue to attach it to a strip of laminate that's the length of your fence. Stick the strip to the face of your rip fence, and slide it down, flush with the tabletop. —Rod Barnard, Seattle, Wash.

Methods of Work buys readers' tips, jigs and tricks. Send details, sketches (we'll redraw them) and photos to Methods, Fine Woodworking, PO Box 5506, Newtown, CT 06470-5506. We'll return only those contributions that include an SASE.

Ripping crooked stock on the bandsaw

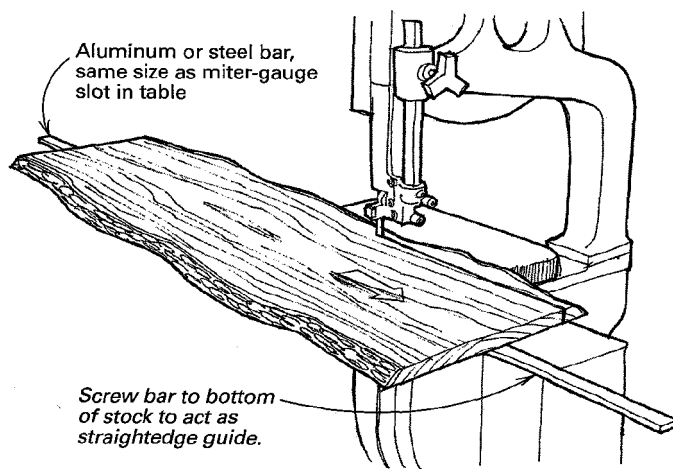

Here is a cheap, easy way to straighten a rough-edged or crooked board on the bandsaw. Screw a length of aluminum or steel-bar stock to the bottom of the board. Then push the stock through the saw with the bar riding in the miter-gauge slot to guide the cut. To know exactly where to fasten the bar, mark the cut line, and then space the bar over the distance from the blade to the table slot. Extend the bar several inches from each end.

When ripping on the bandsaw, you don't have to worry about kickback, which is a problem on the tablesaw. I prefer to use a $\frac{3}{4}$ -in. resaw blade for this operation because it doesn't deflect as much from the pressure of a heavy plank.

-David B. Bills, Fairport, NY.

Under-stair storage drawers

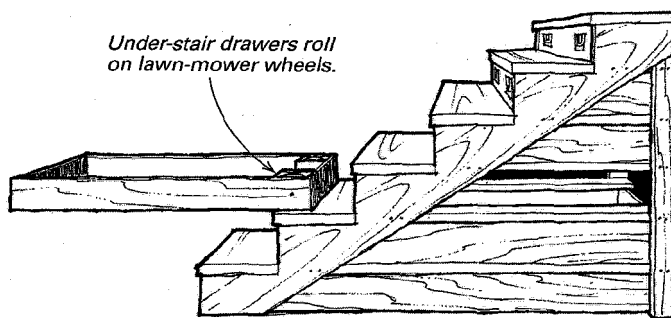

When I set out to add under-stair storage to my basement shop, my first idea was to build a set of drawers accessible from the side. But the drawers would be limited to a 40 in. depth (the width of the stairs), and I would have to keep the space in front of the drawers clear so they could be opened. My wife pointed out that if I turned things 90° and placed a drawer under each step, I could make them as deep as I wanted, and the drawers wouldn't waste any floor space. This approach really appealed to me because the stairway was probably the only space in the shop that was always clear and uncluttered. I could always get to the drawers, and I'd never have to move anything out of the way to open them.

The drawers are plywood boxes with poplar fronts and recessed handles. They vary in length, shorter on top, longer as you go down. The bottom drawer is 7 ft. long. Because the drawers are quite heavy, I mounted 4-in.-dia. lawn-mower wheels in the back corners, which roll on 2x4 tracks. There are

no wheels in front. To open a drawer, I lift the front slightly and pull. With gravity working as a latch, I don't have to worry about a drawer opening on its own. For safety, I keep the door at the top of the stair locked whenever I have a drawer open.

-William R. Robertson, Kansas City, Mo.

Dimensioning wood inlays

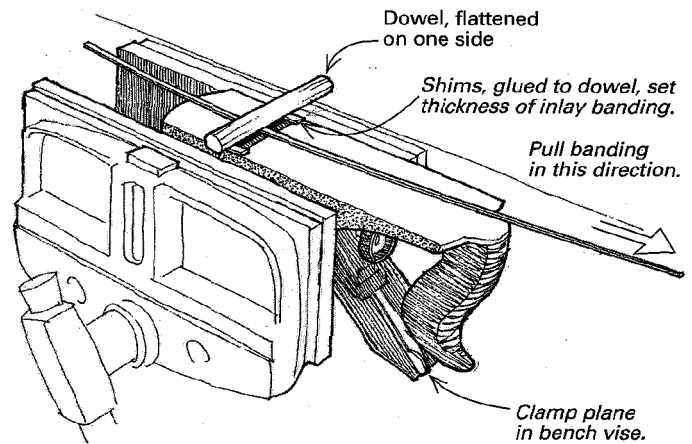

I recently discovered this low-tech but effective technique for planing strips of holly into $\frac{1}{16}$ -in.-thick guitar-edging inlay.

Clamp a sharp plane, sole up, in your bench vise, and adjust it for a fine cut. Glue two pieces of $\frac{1}{16}$ -in.-thick scrapwood to a 6-in. length of $\frac{1}{2}$ -in. dowel, flattened on the bottom. To dimension each strip of holly, hold it against the plane blade with the dowel while you pull the strip toward you. Repeat until the plane stops cutting. The scrapwood spacers will terminate the cut when the holly is precisely the same thickness as the spacers.

-Donnie Ross, Aberdeen, Scotland

A safer stop block for cutoff work

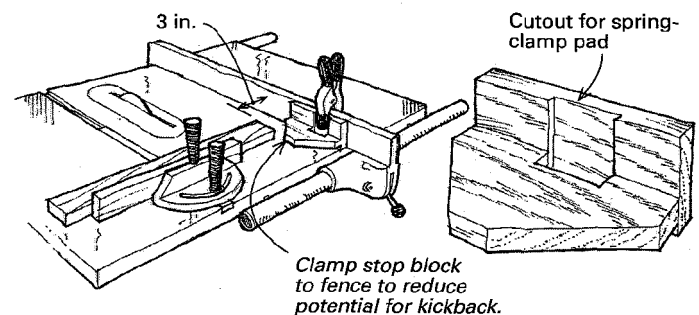

You might file this under the "what happened?" heading. I was making multiple crosscuts on a tablesaw with a miter gauge, using a 1-in. standoff (acting as a stop block) clamped to the rip fence. I had done it this way many times without incident. Anyway, I was cutting 5-in.-long blocks from 3-in.-wide stock. While removing a cutoff, I must have moved it in a twisting motion, so it touched the blade. The stock briefly jammed between the fence and blade. The block bounced off me and drove itself into the wall behind me. Recreating the accident, I found the diagonal measure of the piece exceeded the distance between the fence and the blade. Jammo-whammo.

So I made a 3-in.-wide standoff for the fence. It's nothing fancy: just two pieces of scrap, one vertical, one horizontal. I made

it exactly 3 in. wide, so I can clamp it to the fence and then set the fence 3 in. beyond the length desired. Now there is plenty of room to remove stock. There has been no repeat incident.

—Jim Wright, Berkley, Mass.

Lid support for a small chest

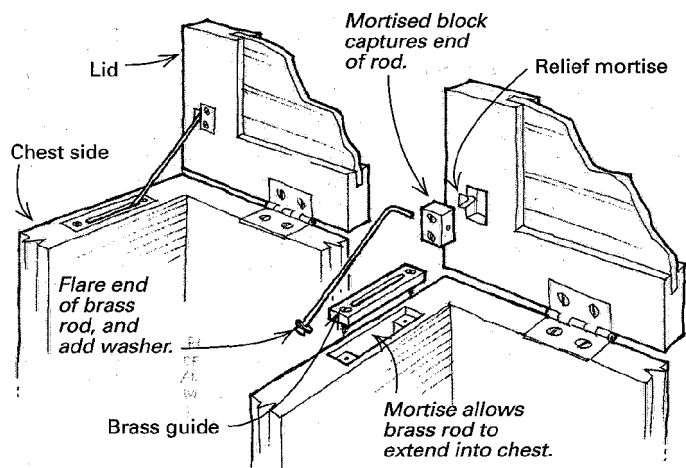

Here's how to make an inexpensive lid support for a small chest with 1/8-in. brass rod. Determine the length of the rod by making a life-sized sketch of the chest and lid. Bend the rod at 90° on one end, and flare the rod at the other end to catch a small washer. Insert the 90° bend into a wooden retainer block. Then fit the retainer block into a small mortise in the lid. Add a small relief mortise on the inside of the lid to accommodate the rod. Cut a deep mortise into the chest side, and cover the mortise with a slotted cover as shown. You can make the cover with brass or wood. The relief mortise in the lid and the deep mortise in the side should allow the rod to travel its full range as the lid closes.

—Mark Moffatt, Denver, Colo.

Quick tip: Remove pencil marks with lacquer thinner. It is easier and more effective than sanding, and it works in tight corners.

—Susan Caust Farrell, Searsport, Maine

Making faceted drawer pulls

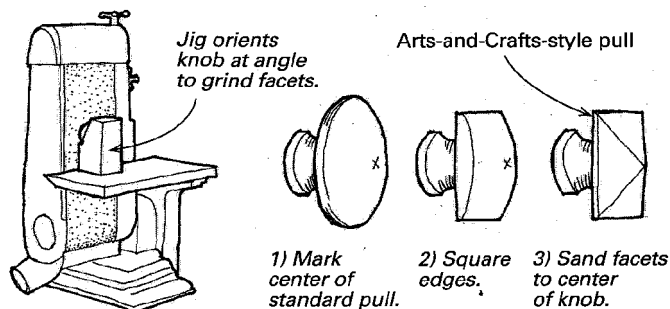

My wife wanted me to reproduce square-faceted wooden drawer pulls to match the ones on her grandmother's Arts-and-Crafts-era highboy. None of my hardware catalogs had any good replacements. Then I realized that I could adapt the common rounded pulls that most hardware and lumberyards sell.

I marked the center of each pull with an X and belt-sanded the edges on four sides. This left a nice square pull with a rounded top. Then I made a jig out of scrapwood to align the pull against the stationary belt sander at an angle of 10° or so. I made the jig

the same width as the foot of the pull, so I can get my fingers around the jig. I grip the setup with one hand to grind facets on the top of the pull. I push the jig into the belt sander, watching the facet grow until it reaches the center of the X. Next I flip the pull over to machine the opposite facet. Finally, I sand the remaining two sides, stopping when each facet approaches the center of the X.

—Robert F. Vernon, Indianapolis, Ind.

Quick tip: Use a dart sharpener to touch up your blunt awl. These sharpeners, which are 1-in.-long hollow cylinders made of Carborundum, sell for about a dollar in sporting-goods stores.

—John Burke, Northfield, N.J.

Modifying hand screws to clamp mitered frames

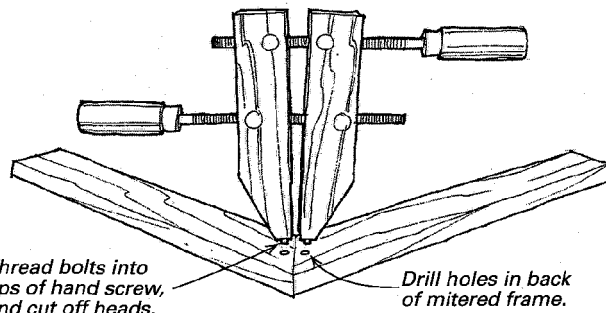

To clamp mitered frames, you can squeeze the joint via pocket holes drilled in the back of the adjacent parts. Two manufacturers offer clamps for this: Universal Edge-to-Edge clamp (W. MacNiven Conard, P.O. Box 250, Vershire, VT 05079; 802-685-4441) and Jorgensen adapter tips (Adjustable Clamp Co., 417 N. Ashland Ave, Chicago, IL 60622; 312-666-0640).

To make your own clamps, add metal pins to a hand screw, as shown. Make the pins by screwing bolts into tapped holes and then cutting or grinding off the heads. To use, drill holes in the back of the frame, and use the pins to apply pressure. Angle the tips toward the center of the work.

—Glen Carlson, San Diego, Calif.

Drilling adjustable shelf-pin holes

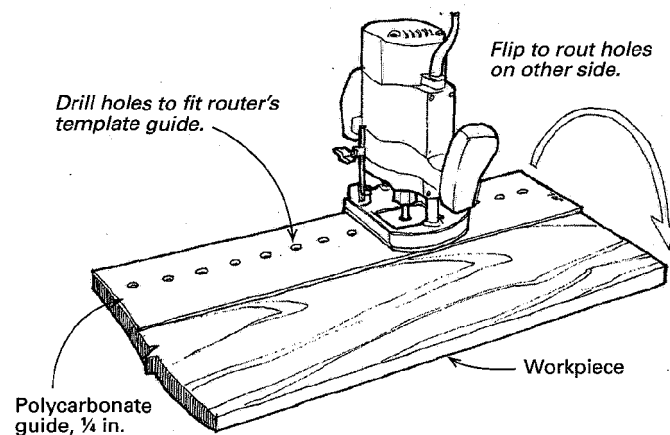

The best way to drill adjustable shelf-pin holes in cabinets is with a 1/4-in. bit in a plunge router. This is especially true for materials like melamine. You'll need a guide with holes to fit the router's template guide. M.E.G. Products (9) John Lenhardt

Road, Hamilton Square, NJ 08690; 609-587-7187) makes an aluminum template for this. Polycarbonate, 1/4 in. thick, also is a good choice for the pin-hole guide.

For my guide, I used a drill press to make 7/16-in. holes (to match the diameter of my router's template guide) on 1 1/2-in. centers. On one end of the template, write "top," so when you are setting up to bore holes in the workpiece, you can orient the template the same way.

To use, clamp the template along one edge of the cabinet with spring clamps and two pieces of double-faced tape. Then plunge the router in all of the pilot holes. When you are finished with one side, flip the template, and move it to the other edge, making sure "top" is at the top of the cabinet.

—L.L. ChipLutz, Puyallup, Wash.

EDITOR'S NOTE: This method also was submitted by Leslie O. Payne, Gaston, Ore.

Removable toolbox for a tablesaw

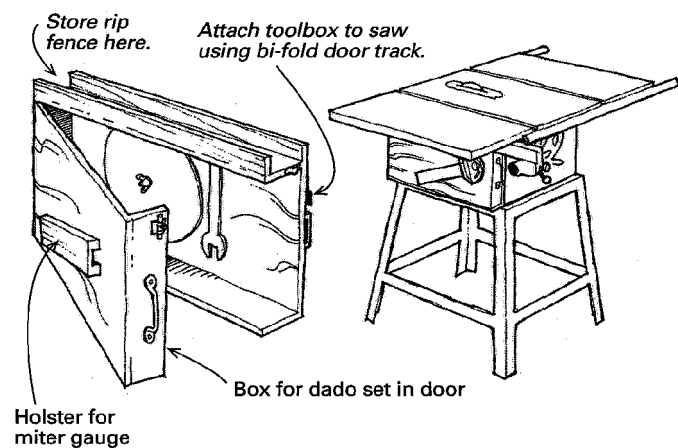

I made this removable tablesaw toolbox for easy portability on construction jobs. The 3/4-in. plywood box holds sawblades, a dado set, table inserts and so on. I added a channel to the top of the box to hold the rip fence when it's not needed. A hollow cleat on the side holds the miter gauge. I attached the box to the saw with a section of a used bi-fold door track so that I can slide the box off the saw.

—Harvey W. Byler, Burton, Ohio

Quick tip: Use the plastic lids from 35mm film containers as wood-protecting cushions under C-clamp pads.

—Orv Dunlap, Phoenix, Ariz.

Fold and layer sandpaper to make it last

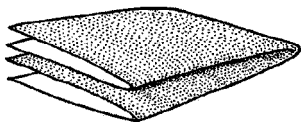

Traditional way of folding sandpaper causes it to wear out quickly.

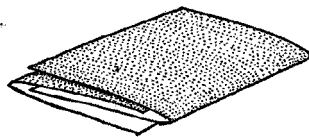

Cutting sheet in two and inter-leaving halves make sandpaper last longer.

Tear a piece of sandpaper in two, fold each piece in half and slip the pieces together (see the drawing at right above). The resulting sanding pad will hold its shape and last much longer than a pad made by folding a sheet in half and doubling it over again.

Having the paper side mate with the grit side eliminates the sliding and shifting that quickly breaks down sandpaper folded the more common way.

—Peter Moffa, Santa Barbara, Calif.

Getting tight-fitting back panels

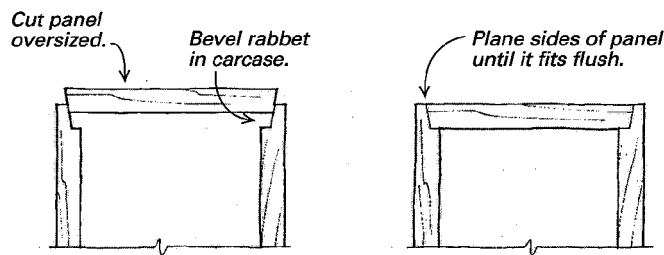

I like to finish the back of a cabinet neatly, so the buyer can use it away from the wall. But it is difficult to fit a back panel into the traditional square rabbet in the carcass without leaving an unsightly gap. You have only one good chance for a snug fit. An improved approach, which I discovered in Joyce's book *Encyclopedia of Furniture Making*, is to bevel both the rabbet and the back panel.

Start by cutting a rabbet, beveled 8° or so, in the carcass sides. You can use a router or your tablesaw to do this. Assemble the carcass. Now cut the back panel about 1/8 in. to 3/16 in. oversized. Bevel the edges of the panel to match the bevel in the carcass. For the first fitting, the oversized panel will sit proud of the carcass, so begin planing and test-fitting the panel into the carcass until it is flush. With patience and several test-fits, you should be able to achieve a no-glue joint on all four sides.

—Tony Konvaloff, Bettingham, Wash.

Snugging up dust-collector connections

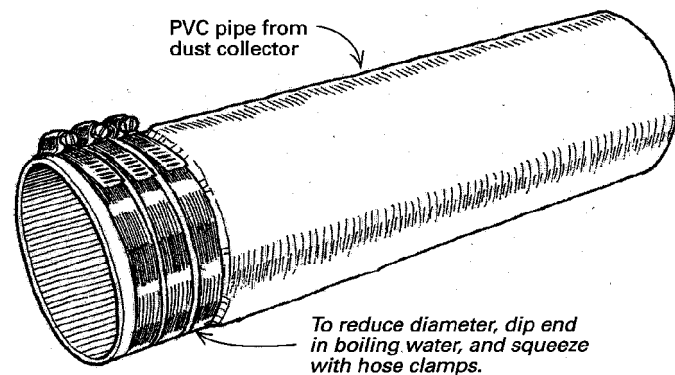

Installation of my new dust-collection system went well until I tried to connect the 4-in. flexible hose I had ordered to 4-in. Schedule 20 PVC pipe. The hose was too small for the end of the pipe. To reduce the diameter of the pipe, I attached three hose clamps to the end and dipped the pipe into boiling water. Then I tightened the clamps just enough to make the pipe the proper size. When it cooled, the PVC-pipe end had retained its smaller size. It fit snugly into the flexible hose.

—Ian Walker, Stonington, Maine

Methods of Work buys readers' tips, jigs and tricks. Send details, sketches (we'll redraw them) and photos to *Methods of Work*, Fine Woodworking, P.O. Box 5506, Newtown, CT 06470-5506. We'll return only those contributions that include an SASE.

Extension fence helps straighten crooked stock

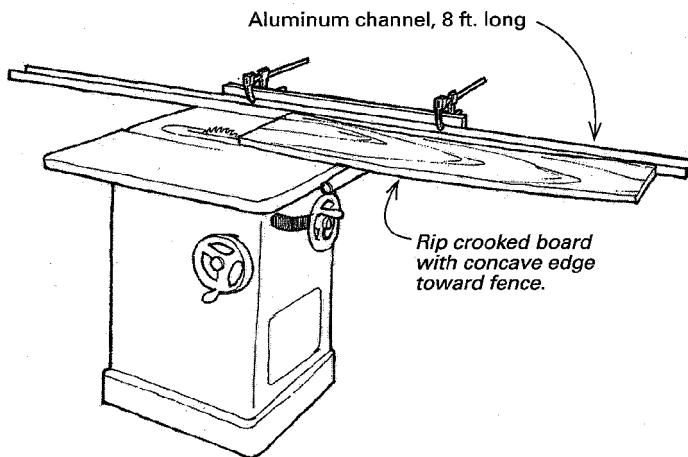

I put off building one of those carriage fixtures for straightening crooked-edged boards for several years. The fixtures require expensive hold-down clamps, and they reduce the possible depth of cut by holding the workpiece off the saw table. The real problem was that the length of the regular rip fence is too short.

Then I noticed an 8-ft-long piece of aluminum channel leaning in the corner of my shop. I clamped the channel to the rip fence, as shown, to produce an auxiliary fence that would guide fairly long stock in a straight line. To use the auxiliary fence, I just put the concave side of the board against the long fence and push it through. It works. —William Mondt, San Diego, Calif.

Aligning drawer slides with a square

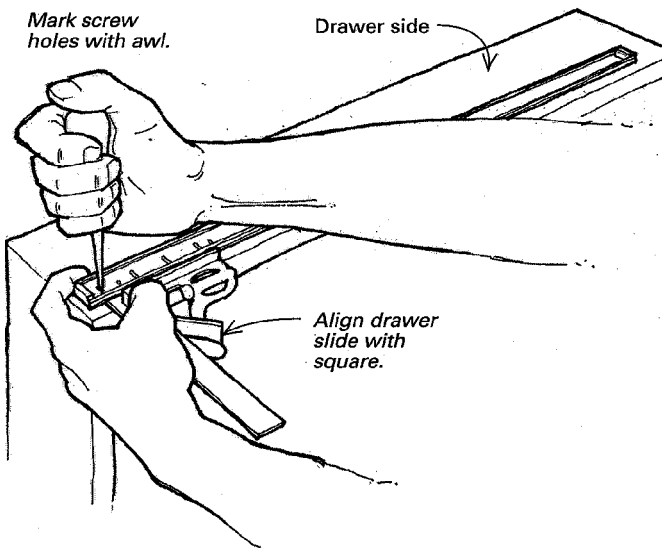

If I have to install a number of side-mounted drawer slides, I take the time to make up an alignment jig from scraps of wood. But if I'm doing only one or two drawers, I use a combination square as a quick-alignment jig.

I set the blade of the square to the distance I want to offset the slide hardware from the bottom edge of the drawer. Then with one hand holding the head of the square tight to the drawer box and the slide tight against the blade, I mark the forwardmost screw center through the attachment hole using an awl. I set a

self-tapping screw in the hole made by the awl, slide the square to the back of the slide, and mark and set a screw there.

—Jim Tolpin, Port Townsend, Wash.

Quick bowl mounting

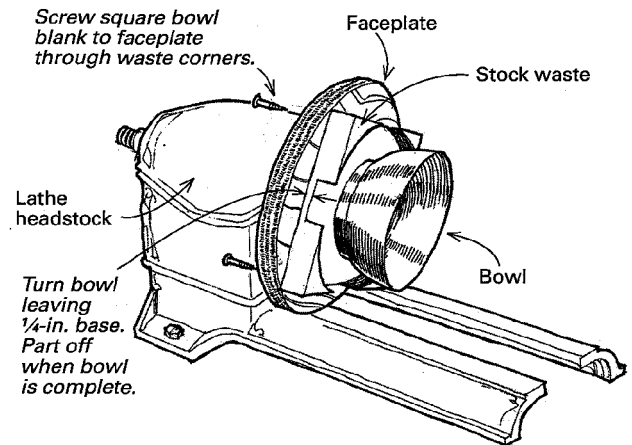

Here's a quick, simple way to attach a bowl blank to the lathe. The method requires a faceplate larger than the finished bowl.

Start by screwing the square bowl blank to a faceplate in the corners using the shortest screws that will attach the blank. I use 3/4-in.-long screws for all but the largest bowls. If your faceplate is too small, then enlarge it by attaching a 3/4-in. plywood disc. Now turn the bowl inside and out, being careful not to hit the screws in the waste corners. Leave the last 1/4 in. thickness of wood next to the faceplate.

The bowl is now complete except for the bottom. Continue turning at the slowest possible speed, carefully angling a parting tool to release the bowl from the lathe. The bowl will not fly across the shop; it can be picked from the lathe as it is parted off.

—Peter Sibbald, Lyndhurst, Ont, Canada

Quick tip: To fill cracks and defects in wood, pack sanding dust into the voids, and zap the filler with cyanoacrylate glue. After the glue sets, sand the surface flat, and repeat if necessary. Be sure to use safety glasses when using the cyanoacrylate adhesive.

—Dennis W. Hetzner, Canton, Ohio

Coat hanger makes a spring-clamp holder

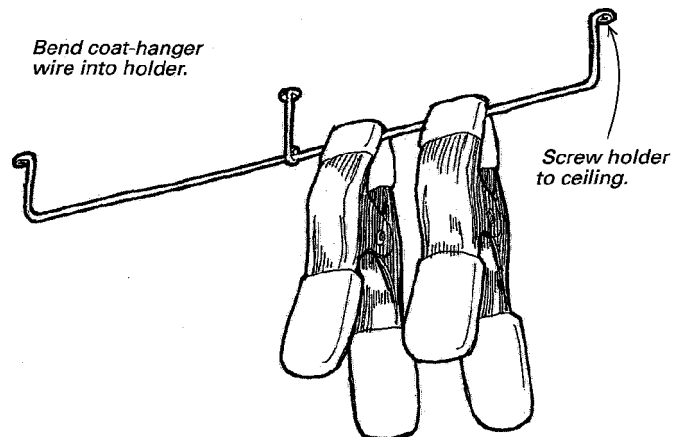

Here's how to make a convenient hanger for your spring clamps. Form a U-shaped bracket from coat-hanger wire using needle-nosed pliers. Screw the bracket to the ceiling over your

bench. The hanger has two advantages: First, the clamps are located close at hand, and second, the clamping springs aren't in tension when not being used. —Anthony Guidice, St. Louis, Mo.

Router setup for edge-jointing

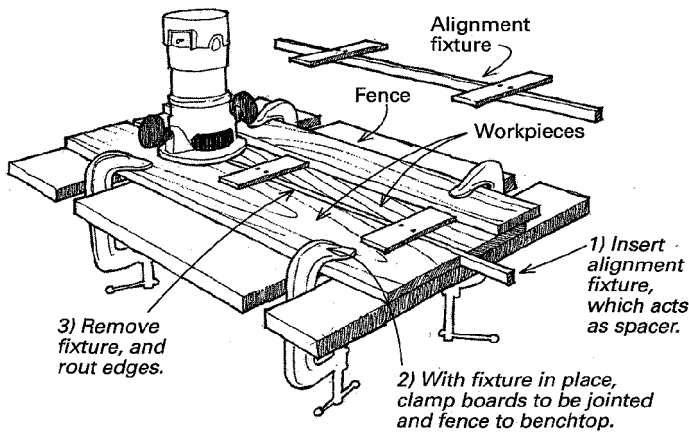

This method provides a quick and accurate setup for jointing the edges of stock with a router. Make a two-piece jig that consists of an alignment fixture and a fence. The fixture sets the proper spacing of the boards. A single pass of the router shaves a little off each board. The best spacing is about $\frac{3}{32}$ in. smaller than the router bit. The fixture also sets the location of the fence. This is accomplished by cutting the two cross pieces the same length as the diameter of your router base.

To use the jig, set the two boards to be jointed on the bench with the alignment fixture between them. Slide the fence against the cross pieces of the fixture, and clamp the boards and fence to the bench. Remove the alignment fixture, and make one pass with the router to joint the two boards.

Once the jig is made and tuned, you can joint two boards in less than a minute. The resulting pieces will mate perfectly.

—Jeff Colla, Eden Prairie, Minn.

Quick tip: To prevent bandsaw blades from rusting, store the coiled blades in an airtight cake pan along with a couple of those little moisture-absorbing (desiccant) packs.

—Paul Burri, Ventura, Calif.

Pocket-making jig for a router table

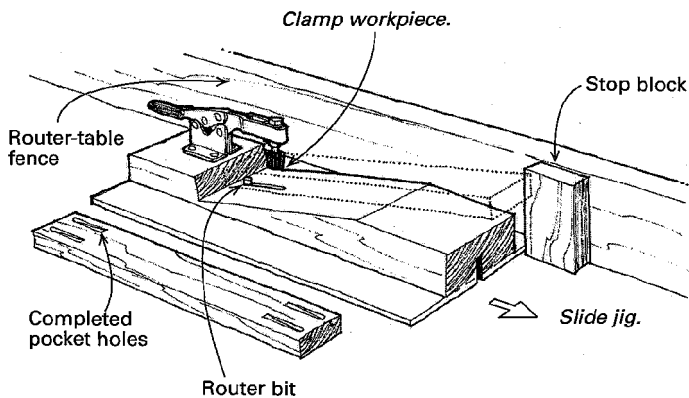

Here's a router-table technique for producing clean, precise pocket holes for joining face-frame members. First, construct a wooden cradle fitted with a lever-operated toggle clamp. The

cradle angles the workpiece as pocket holes are milled. To cut the pockets, mount a straight cutting bit in the router, and with the workpiece clamped in the fixture, slide the fixture along the fence on the router table. A stop clamped to the fence prevents the pocket from running out the end of the workpiece.

To complete the pockets, drill screw-shank-sized holes from the end of the board to meet the pockets. Face-frame assembly is simple. Just clamp the stiles and rails together with glue, and drive screws through the pockets.

—Paul K. Murphy, San Jose, Calif.

Hiding the wires in wooden light fixtures

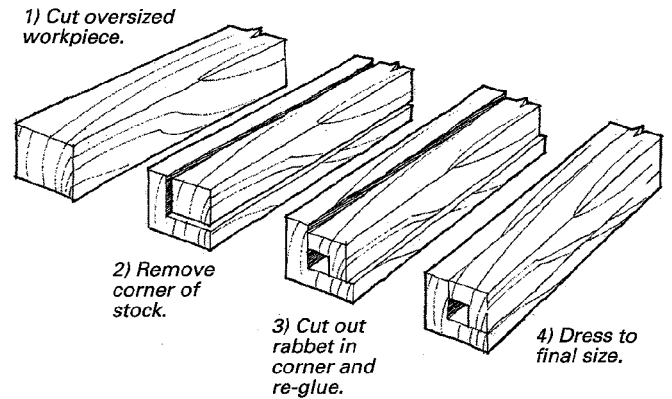

I needed to hide electrical wire inside one of four 4-ft. wooden sticks that held a Mission-style light. I wasn't about to attempt drilling a hole that long. So my solution was to cut the stick oversized, rip out one corner of the stick, rout a rabbet in the corner of the removed section and then glue up the two pieces. I then thickened the joined stick down to the desired $\frac{3}{4}$ -in. cross section. Now the stick can't be distinguished from its three neighbors, even though a hole runs through it straight as an arrow.

—Saul Isler, Cleveland Heights, Ohio

Replacing a spindle in a chair back

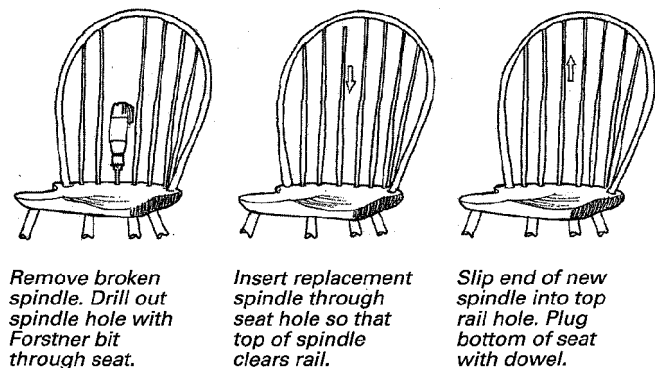

Here's how to replace a spindle in a chair back without having to disassemble the entire back. First remove the broken spindle. Then drill the bottom hole all the way through the seat with a Forstner bit. Slide a new spindle into the hole far enough to allow it to pass under the top rail. Then raise the spindle up into the hole in the top. Plug the hole in the seat bottom from the underside to complete the job.

—Jon Gullett, Washington, Ill.

Quick tip: The innards of a worn-out measuring tape make a great wire-fishing tool. You can use it to pull speaker wires into

the back of a cabinet or to pull Romex cable into a stud space for an outlet or switch. Simply push the tape into the space from one opening to another, hook on the wire and pull.

—Craig C. Steele, Carson City, Nev.

Hose clamps to the rescue

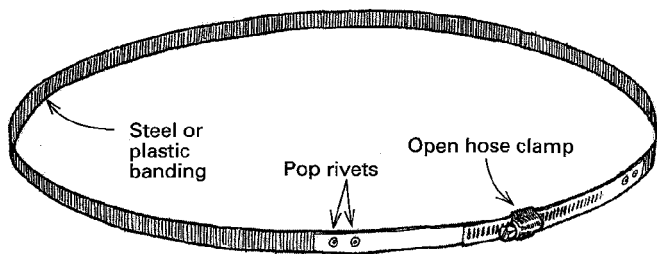

After several mishaps with the bag coming off my dust collector, I made up a new band with a hose clamp, as shown. Start with a 4-in. hose clamp. Cut it in two about midway, and pop-rievet a length of steel or plastic band (the kind used to secure shipping cartons) between the two ends to lengthen the clamp to whatever size you need.

—Ray Namiotka, Pittsburgh, Pa.

Quick tip: Smaller air tools can be operated at remote sites directly from a portable air tank, like the propane tanks used for barbecue grills. You can purchase air tanks ready to use or adapt a propane tank with a \$5 valve kit. Make sure the tank has a safety valve, and monitor the pressure with a gauge when you're charging up the tank.

—Sven Hanson, Albuquerque, N.M.

Removing raised-panel waste on the bandsaw

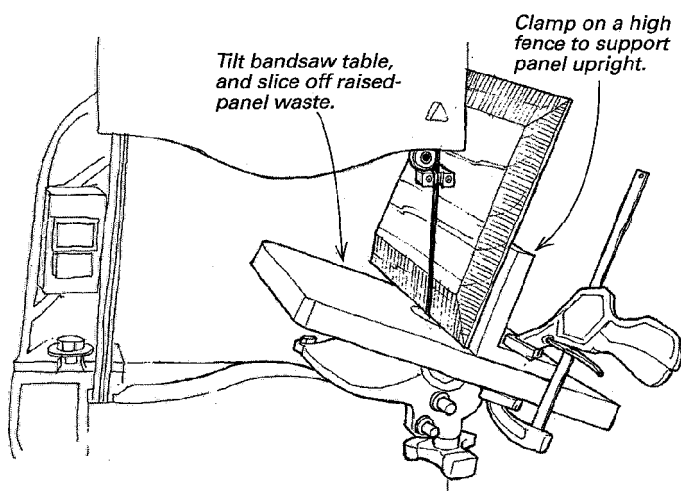

Although my shaper reluctantly will profile the edge of a raised panel with one pass, I feel that it is safer and more efficient to remove some of the waste stock first. I use my bandsaw, which is safer and faster than the tablesaw. Tilt the table, raise the guide, adjust the fence and have at it.

—D. Kenney, Middlesex, Vt.

Reducing slippage with moist paper towels

I discovered that a damp paper towel under a cutting board prevents the board from sliding around on the countertop. This method works equally well for anchoring an oilstone or a sheet

of plate glass to the bench. I do this when I'm honing the sole of a bench plane.

—James R. MacMahon, Maitland, Fla.

Sharpening guide for a grinding wheel

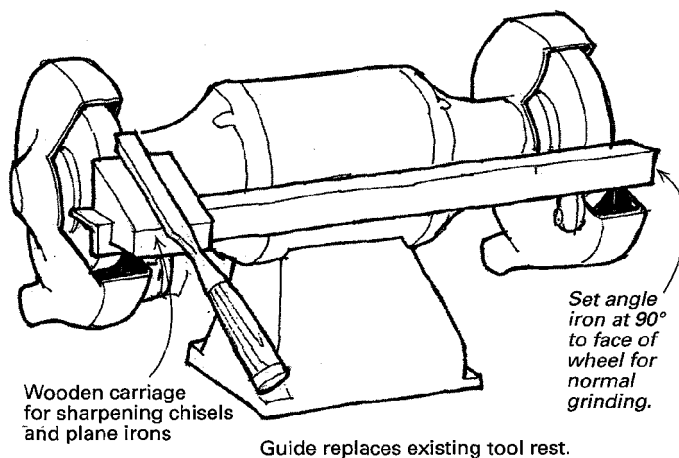

I removed the guides (tool rests) that came with my grinder and replaced them with a single piece of steel angle that spans both wheels. I use this guide for normal grinding. Then I made a sliding wooden carriage that correctly angles chisels and plane irons. This arrangement lets me switch quickly between straight and angled grinding. I use 80-grit, white aluminum-oxide wheels, which run cooler than standard wheels.

—Frank Norman, South Perth, Western Australia

Quick tip: Rub soapstone (welder's chalk) on a clean file to minimize clogging, especially with soft metals.

—Jim Good, Fox, Ark.

Space-saving router table mounts to bench

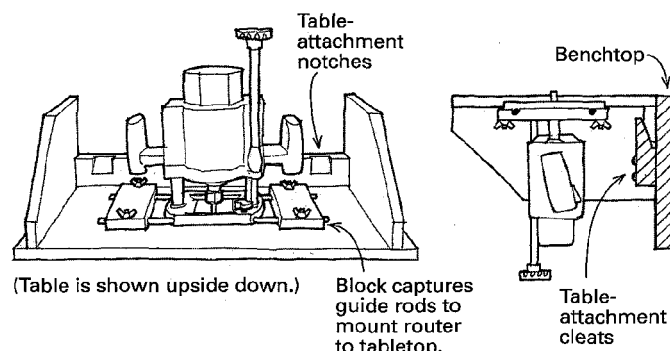

This router table is quick to set up and hangs on the wall when not in use. A plunge router attaches to the table's underside using the rods provided for the router's guide fence. Nothing need be removed from the router. Once the router has been attached to the table, you can flip it over and slip the table onto wedge-shaped blocks bolted to the front of your workbench. The table is held securely by the blocks. The total time for mounting or dismantling is minimal.

—D.A. Kennedy, Rugby, England

Methods of Work buys readers' tips, jigs and tricks. Send details, sketches (we'll redraw them) and photos to *Methods of Work*, Fine Woodworking, P.O. Box 5506, Newtown, CT 06470-5506. We'll return only those contributions that include an SASE.

Sandpaper cutter

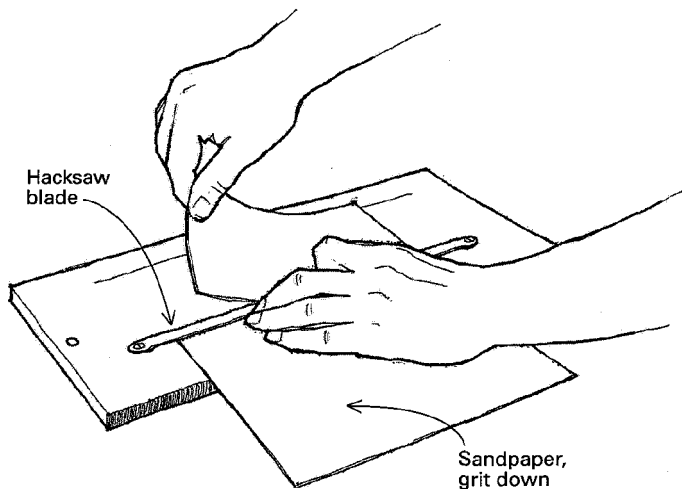

If you're like me, folding and tearing sandpaper along the crease isn't always successful. Try making this simple cutter. Screw an old hacksaw blade to a strip of scrap plywood. Insert a screwdriver under the blade, and twist the screwdriver to provide ample clearance for the sandpaper. To use the cutter, slide the sandpaper, face down, under the blade. When the sandpaper is in position, push the blade down, and pull the sandpaper up. The sandpaper will cut cleanly against the serrated blade.

—Anthony Guidice, St. Louis, Mo.

Quick tip: To organize the various scraps of paper around my shop (plans, receipts, user manuals), I glued spring clothespins to shelves, jigs, overhead beams and workbench legs. For a small investment, you can put a lot of order in your shop.

—Steve Tkaczyk, Gaithersburg, Md.

No-slip sanding board

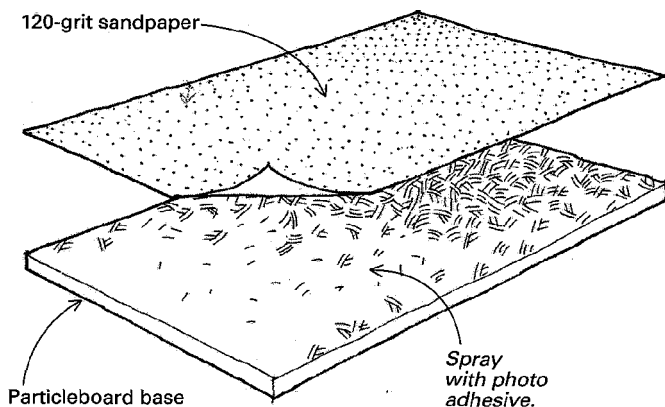

Here is a no-slip sanding board I use for sanding small pieces of wood with an orbital sander. It's always a daunting task when the pieces are too small to be clamped. I use 120-grit sandpaper glued to a piece of 3/4-in. particleboard or plywood—anything, as long as it is flat. I cut the plywood to the size of a full sheet of sandpaper and use 3M #77 spray adhesive for a quick mount. Place the sanding board on your benchtop, and lay your small workpiece on top of it. Hold with a finger or two, and sand away. Make a new one when the pieces begin to slip under the sander.

—Spider Johnson, Mason, Texas

Tandem spring clamps apply more pressure

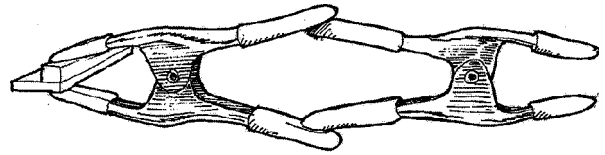

Spring clamps can be made to exert more pressure by compressing a second clamp and placing its handles between those of the first clamp. When you release the second clamp, its spring will add to the strength of the first.

—Paul K. Murphy, San Jose, Calif.

Tool for measuring inside frames for panels

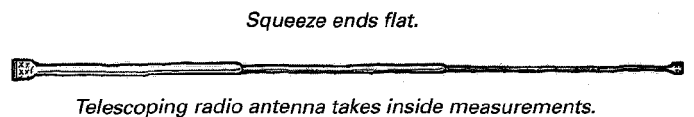

To size panels to fit a frame, it's important to measure the exact length and width of the frame space. But it can be difficult measuring from the bottom of the grooves in which the panel fits. My solution is to use an old car-radio antenna with tips that have been squeezed flat 1/2 in. or so on each end (clip off the tip at the small end first). I telescope the antenna until it bottoms out, top and bottom, in the panel grooves. Then I remove the antenna and transfer the measurement to a rule. The antenna sections have enough friction to hold a measurement.

—J. Kirkham Jenner, Grants Pass, Ore.

Quick tip: To coat wooden objects smaller than 10 in. across with an oil finish, pour a small amount of oil into a resealable plastic bag. Place the wooden object in the bag, and slosh the whole thing around. After removing the object, pour any remaining finish back into its original container.

—Carl R. Faix, Cherry Hill, N.J.

Flattening the bottom of turned bowls

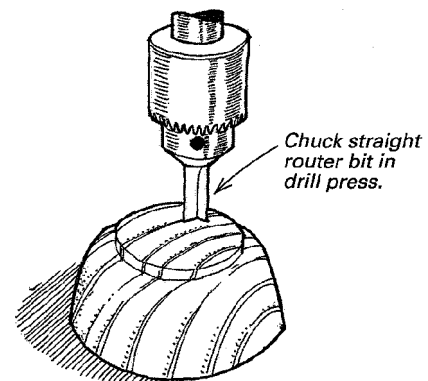

To trim down and flatten the base of a turned bowl, chuck a straight, dado-cutting router bit in the drill press. With the bowl inverted on the table, position the quill (or table) so that the bit takes a skimming cut off the bottom of the bowl, and then lock the quill. Use light cardboard between the bowl and the table to prevent damage to the bowl's rim. Slide the bowl over the table

to mill the base. Take light cuts, lowering the quill repeatedly until the base is at the desired height.

—Charlie Morrison, Powell River, B.C., Canada

Squaring the fence on a tablesaw cutoff box

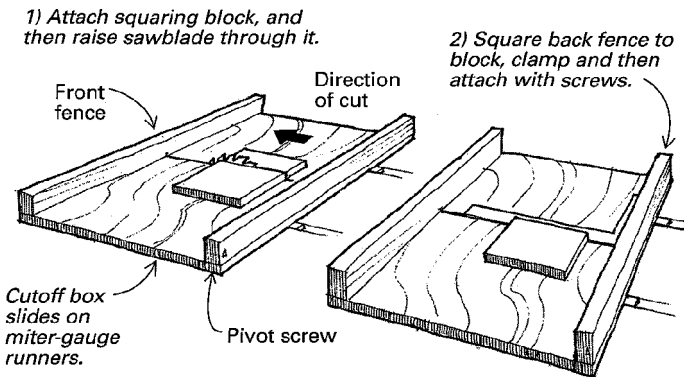

I've found an easy way to set the back fence on a tablesaw cutoff box perfectly square to the cut line: Build the cutoff box to the dimensions you need, attach rails to run in the tablesaw miter-gauge slots and attach the front fence securely to the box. (The front fence is the one farthest away from you when you're using the saw.) Attach the back fence with one wood screw through the bottom in the left corner to allow the fence to pivot.

Now attach a piece of scrapwood near the back fence with double-faced tape. This will be used as a squaring block. Raise the sawblade through the bottom of the cutoff box, and cut through the squaring block but not through the back fence. Remove half of the squaring block, and pivot the back fence until it is square to the remaining squaring block. Use an accurate framing square for this. Clamp the back fence in place, and attach it with screws through the bottom. Remove what's left of the squaring block, and you're set.

—Tony Busch, Port Orchard, Wash.

Carriage bolt joins bed rail to bedpost

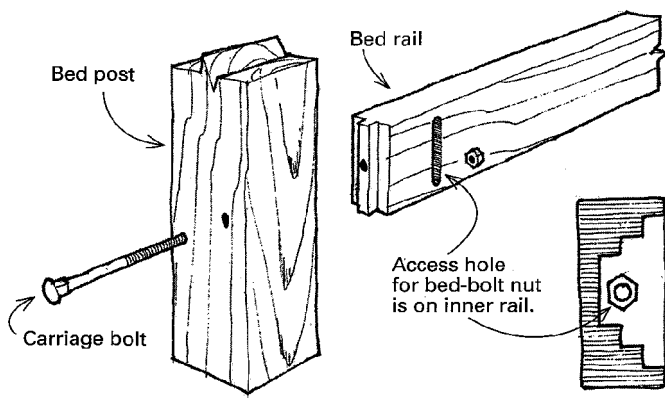

A carriage bolt can be used to fasten a rail to a post in a bed frame. It's a variation of another better-known approach that uses a captured nut in the rail and a bolt tightened from the post side. In the version shown above, a carriage bolt is captured in the post, and the nut is tightened in the rail with an open-ended wrench. To leave room to swing the wrench, plunge-rout a 1/2-in.-wide slot in stepped depths into the inner face of the rail.

One bolt will suffice for small rails, but wide rails will require two bolts. If you wish, recess the bolt heads so that you can cover them with bed-bolt covers.

—Andy Westerhaus, Bumsville, Minn.

Scrapers from old jointer knives

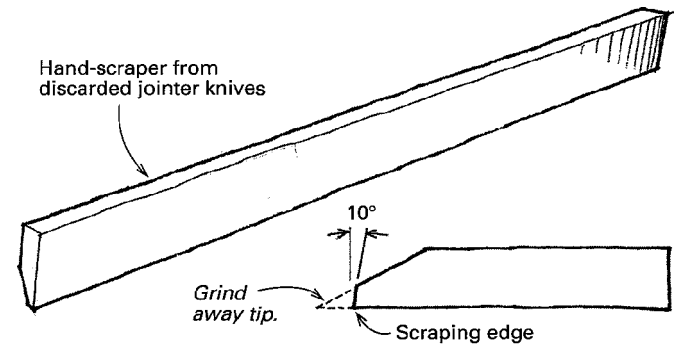

Instead of discarding old planer or jointer knives that are too narrow to use, make scrapers out of them. Grind the front edge to about 10°. Use a fence on the grinder's tool rest to get a straight edge, and use a fine grinding wheel to get a smooth surface with a slight burr. These scrapers won't flex like ordinary scraper blades, and the high-speed steel really holds an edge. There's no need for burnishing—just use the scraper right from the grinder.

—Robert Vaughan, Roanoke, Va.

Quick tip: To cut thin brass with a jigsaw or bandsaw, clamp the metal to a scrap of 1/4-in. plywood. This lessens the vibration and minimizes tooth clogging.

—Jim Good, Fox, Ark.

Shopmade bench screws from dowel rod

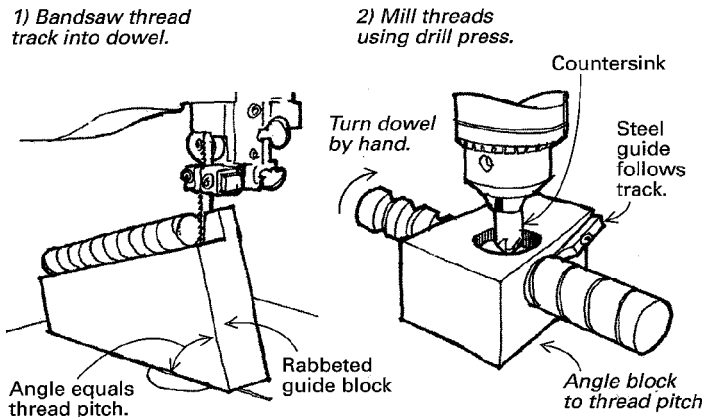

To make bench screws of any size and pitch using ordinary hardwood dowel, start by determining the dowel size and pitch for the threads. Make a rabbeted fixture to bandsaw a spiral kerf (the thread track) into the dowel. The angle of the fixture's base will determine the pitch of the thread, between 7° and 15°. For a right-hand thread, the right-hand side of the fixture must be higher. As you turn the dowel by hand, it will track up the incline.

Next drill a hole slightly larger than the dowel through a block of wood. The dowel should slide easily through the hole with no slop. Drill a larger hole on the flat top of the block. Angle one end of the block to match the pitch of the threads, and attach a steel guide to ride in the bandsawn track. To cut the threads, clamp the

block to your drill-press table, install a regular countersink (or grind one from an old spade bit) in the chuck, and align the block so the bandsaw kerf is directly under the countersink point.

With the drill press running, begin threading the dowel into the block. The spiral cut in the dowel is self-jigging. The countersink rides in the bandsaw kerf—about 1/4 in. deep—with no side-to-side movement. The countersink acts as a short tap. The depth at which you lock the quill sets the thread depth. You can make minor adjustments in the first 1/2 in. or so of length. But take care to get the right depth on the first pass because there is no second chance once a V-groove is formed.

—Dennis R. Brock, Rawson, Ohio

Quick tip: When learning to fold a bandsaw blade, use an old V-belt to practice with first. It's easier on the hands and face.

—Robert M. Vaughan, Roanoke, Va.

Tablesaw jig for making scarf joints

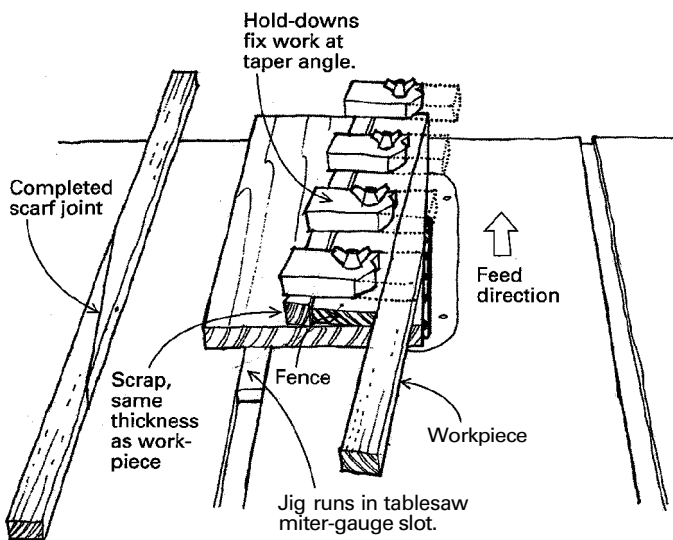

The scarf joint, which joins stock lengthwise without loss of strength, deserves more recognition outside its traditional domain of wooden boatbuilding. Here's how I make the joint for other woodworking projects.

Make a tablesaw jig from a scrap of 1/2-in. plywood, about 8 in. wide by 32 in. long. Attach a runner to the bottom of the jig to ride in the miter-gauge slot. Trim the edge of the jig with a pass through the sawblade. Now attach a 5/8-in.-high fence angled to the blade at 5° (a slope of 12:1). Install four or five hold-downs with machine bolts and wing nuts, as shown.

To use the jig, locate the piece to be scarfed tightly against the fence, and clamp with the hold-downs. Support the left side of the hold-downs with a piece of material the same thickness as the workpiece. With the sawblade set slightly deeper than the material to be cut, make a pass through the saw.

To keep the joint parts in registration during glue-up, drill a small hole through the splice, and drive in a small round dowel or bamboo skewer.

—William R. Fuller, Dewitt, N.Y.

Sharpen your hammer?

Many years ago when I was helping an old man install trim on kitchen cabinets, he stopped me and said, "Sharpen yer hammer first." I looked at him suspecting some ruse like a snipe hunt or left-handed monkey wrench. Instead, he showed me how to rub the face of the hammer on abrasive paper to make a non-skid

surface. Then he did the same with the nail set. Subsequently, there was a wondrous feeling of certainty and coupling in each blow. The non-skid finish doesn't last long on the hammer, but it doesn't take long to renew. Since that lesson, I almost never make a mule track or send a nail set spinning across the shop.

—Joseph Whitehill, Chestertown, Md.

Quick tip: To make a disposable felt buffing wheel, cut a 6-in.-dia. disc from 3/4-in. plywood, and enlarge the center hole to 1/2 in. Now attach felt weather stripping to the circumference of the disc with yellow carpenter's glue. Hold the felt in place with thumbtacks every few inches while the glue dries. Charge the wheel with buffing compound as you would a regular wheel. When the wheel glazes over, throw it away, and make another.

—R.B. Himes, Vienna, Ohio

Drilling table pins

Jig for drilling pin holes on edges of extension-table leaves.

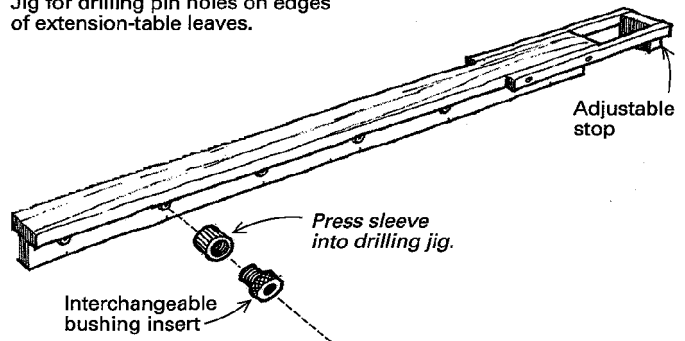

For years I used a doweling jig to drill holes for pins in extension tables and leaves. This approach, unfortunately, requires dozens of separate operations, each subject to the error of misalignment. So I came up with a jig that allows me to drill all the holes on each side of a table part in perfect alignment.

The jig is simply a wooden T-beam containing precisely spaced drill bushings. My jig is 48 in. long with bushings set 9 in. apart. I use two-part drill bushings that consist of a sleeve and a bushing insert (available in various sizes), which threads into the sleeve. Sleeves and bushings are available from the Woodworkers' Store (4365 Willow Drive, Medina, MN 55340; 800-279-4441). The jig, fitted with an adjustable stop on one end, can be centered on different-sized tabletops.

To use the jig, I lay out the tabletop halves and any leaves in their correct positions. Then I mark one end of all parts with an X. This is the reference end that I hook the jig's stop against. I clamp the jig into place, screw appropriately sized drill bushings into the sleeves on the exposed side of the jig and drill the holes. I move the jig to each leaf and drill all the edges in the same way. These are the holes for the pins. To drill matching pin holes in the corresponding leaves, I remove the drill bushings and screw them into the sleeves from the opposite side of the jig.

To make the traditional wooden pins, I use 3/8-in. dowel stock cut to 1-in. lengths. To keep them from binding in the pin holes, I mount the pins in a three-jaw chuck on the lathe and sand down half the length and round the ends. You can also use brass pins (1/8-in.-dia. brass pins that fit the sleeves require 5/16-in.-dia. holes). The pins are also available from the Woodworkers' Store.

—Chris Becksvoort, New Gloucester, Maine

Methods of Work buys readers' tips, jigs and tricks. Send details, sketches (we'll redraw them) and photos to Methods of Work, Fine Woodworking, P.O. Box 5506, Newtown, CT 06470-5506. We'll return only those contributions that include an SASE.

Safer sliding cutoff box

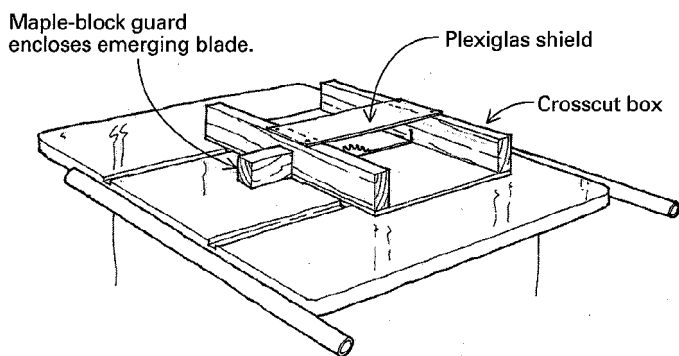

A sliding crosscut box is a big help when working with small pieces of stock on a tablesaw. But the sawblade emerges suddenly from the rear of the box at the end of a stroke just where your fingers could be. This hazard is greatly reduced by adding a hard maple guard (I painted mine red) to the jig where the blade emerges. When the jig is at the end of its stroke, the blade is still safely within the maple block. My guard is held by screws through the back fence. I also added a Plexiglas shield over the blade.

—Michael A. Covington, Athens, Ga.

Router fixture for dovetail pins

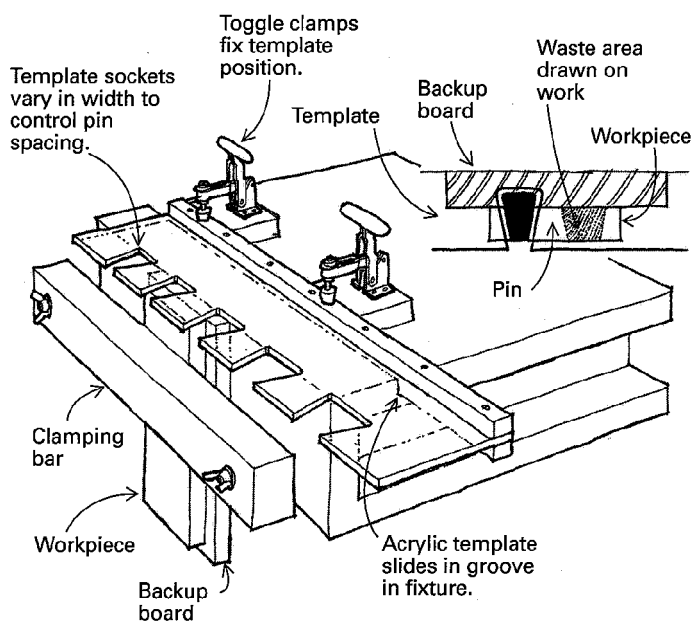

Rout pins with 1/4-in. straight bit and bushing.

My variation on routing dovetails involves cutting the pins with a router equipped with a 1/4-in. straight bit and a bushing that follows an acrylic template.

I mark the pins on the edge of the workpiece, and clamp the work to a fixture made of 1 1/8-in. particleboard. For through dovetails, sandwich a sacrificial piece of scrap between the work and

the fixture to prevent tearout in the workpiece and damage to the fixture. For blind dovetails, clamp the work directly to the fixture.

Slide the template into position over the workpiece. The template controls the spacing between the pins. I've cut several opening sizes on mine. They vary the pin spacing between 3/4 in. and 2 1/4 in., in 1/8-in. increments, depending on the bushing. For accuracy, make the template's angled cuts on the tablesaw.

Clamp the template into place with two toggle clamps, as shown. Set the router to the desired depth, and remove the material between the first two pins. Loosen the clamps, and reposition the template by eye to the layout lines for the next cut. It takes less than 5 minutes to cut the pins on one edge of a typical drawer. When cutting half-blind dovetails, the router bit leaves rounded inside corners that must be cleaned up with a chisel.

To complete the joint, I mark the tails from the pins and cut to the lines with a bandsaw. I chop out the waste with a chisel.

—Jim Hale, Saline, Mich.

Use a drywall screw to tap holes for hinges

I recently made a pair of display cabinets that required many solid-brass hinges. To avoid breaking the soft brass screws, I drilled pilot holes and coated each screw with wax before installing. Nonetheless, I hadn't gone far before I broke the first screw.

As I fumed over the task of retrieving the stub of the broken screw, I got the idea of tapping the screw holes. I ground the Phillips head off a 2-in. drywall screw, filed flats in the shaft to give my drill a gripping surface and began tapping the holes with my reversible drill. I completed the project, which contained 12 doors, without breaking another screw.

—Robert F. Reynolds, Columbia, Md.

Marking frame for hand-cut dovetails

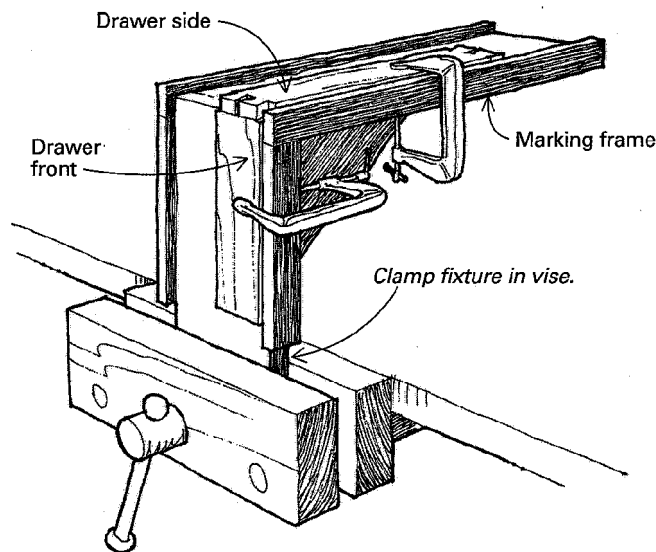

Inspired by the tool cabinets featured in *FWW* #105, I decided to construct a cabinet for my own tools. Because the design called for eight hand-dovetailed drawers, I needed a quick way to transfer

the dovetail layout from the drawer side to the drawer front. I also wanted to ensure that the edges of the top and sides were in the same plane to eliminate any twist in the assembled drawer. So I built a simple right-angle frame with short fences on both edges. This frame allows me to align and clamp the two pieces to be marked. The frame keeps them in perfect registration.

—Alan Cleven, Pointe Claire, Que., Canada

Quick tip: To speed up planing chamfers with a block plane, cock the blade so that one side cuts coarse shavings and the other fine. Use the coarse side to rough out and the fine side to finish up.

—Tony Konavaloff, Bellingham, Wash.

Ball-bearing guides for tablesaw cutoff box

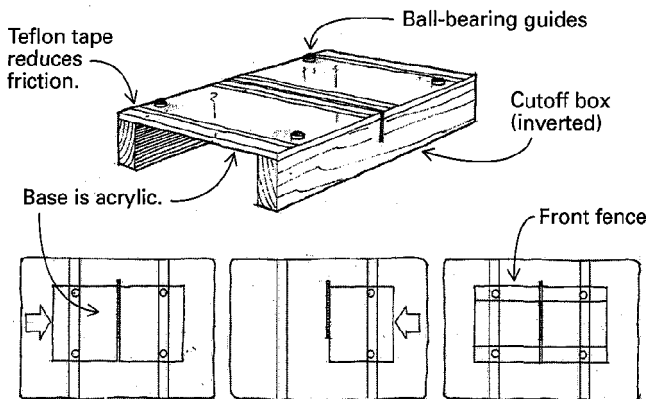

1) Push left two bearings against right side of miter-gauge slot. Cut base in two.

2) Push right side of base to left so bearings contact left side of slot, and cut again.

3) Clamp halves of base together, and attach fences.

The wooden puzzles I make require safe, accurate cuts of small pieces of wood. That's why I designed this cutoff box that uses ball-bearing guides, an acrylic base and Teflon tape.

Start with a 12-in. by 24-in. piece of ½-in.-thick acrylic. Drill four holes, and install bolts for bearing axles. Space the axles in pairs a distance equal to the center-to-center spacing of your saw's miter-gauge slots. The bearings don't need to be precisely located at this stage.

With the bearings mounted, flip the base so the bearings are in the saw's miter slots. Push the acrylic base to the right to cause the two left-hand bearings to contact the right edge of the left miter-gauge slot. Saw the base in half. Repeat this step for the right half of the base, but this time, push it left so that its two bearings contact the left side of the saw's right miter-gauge slot. You now have two pieces of acrylic separated by a sawkerf when the bearings are against the inboard edges of the miter-gauge slots.

Attach the front and back fences to the base using 4-in.-long bolts and washers in oversized holes to provide adjustment. Hold the base on the saw table with bar clamps while you're attaching the fences so you locate the bearings properly. To complete the box, add strips of Teflon tape to the underside of the acrylic base along both sides of the sawkerf and outside of each miter-gauge slot.

Use quick-action clamps to hold workpieces safely in place during cuts. Be careful that you don't push the box too far past the

blade because the box will lose lateral stability. However, stops clamped to the back side of the saw will prevent the bearings from coming out of the miter-gauge slots.—Wayne Daniel, Minden, Nev.

See-through guard for a radial-arm saw

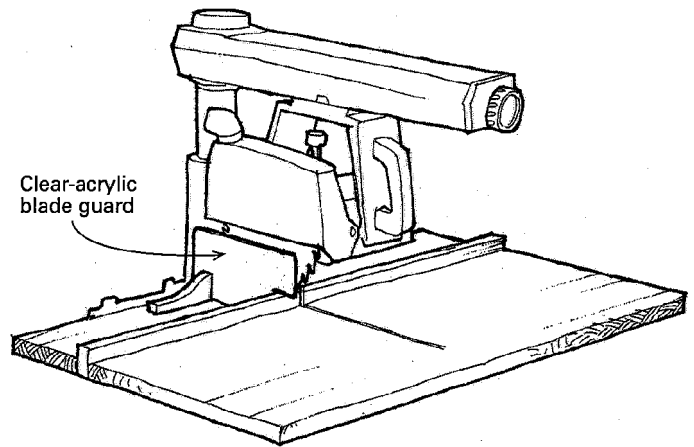

A simple guard made from acrylic plastic, screwed to the radial-arm saw table just to the left of the blade, protects the fingers of your left hand (see the drawing above), yet it still allows you to see the blade clearly. The idea for this guard occurred to me while crosscutting a run of face-frame stock. I noticed that as I slid boards past the carriage with my left hand, one moment of inattention might put my fingers into the spinning blade. With my new windshield guard in place, my hand would hit only the plastic.

—Paul K. Murphy, San Jose, Calif.

Weatherproofing outdoor furniture feet

Leg is shown inverted.

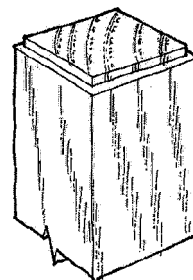

1. Notch corners on end of leg.

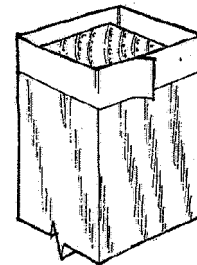

2. Make perimeter dam with tape; fill with epoxy.

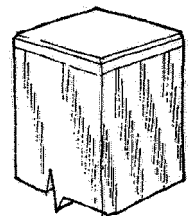

3. Smooth and shape hardened epoxy foot.

Last winter, I built a bench destined for a flagstone porch—a place that can pick up a bit of weather. To prevent the bench legs from wicking moisture and marking the flagstone floor, I devised this method of casting an epoxy cap on the end of each leg

Before assembling the bench, I notched the perimeter of each

foot by cutting a 1/8-in.-deep rabbet with the tablesaw. Then I placed the leg in a vise, foot up, and leveled the bottom in both directions. I wrapped 3/4-in.-wide masking tape around the foot to make a dam. Using West System epoxy, I wetted the bottom of the leg thoroughly with clear epoxy. Then I poured thickened epoxy over the bottom of the leg until the entire foot was covered at least 1/8 in. deep. The addition of the thickener (West System No. 406) is necessary because pure epoxy would be too brittle by itself and would chip or crack. After the epoxy hardened, I peeled away the tape and flattened the epoxy with a sander and a file.

This technique could be used on the legs of any wooden outdoor furniture and might even negate the need to add felt or plastic feet on indoor furniture, especially chairs used on a hardwood floor.

—Douglas A. Mirk, Islesboro, Maine

Polystyrene makes inexpensive pattern material

The pattern material I use for the chairs I build is white, high-impact polystyrene, available from plastic distributors. I get the .040-in.-thick material in a 40-in. by 72-in. sheet for about \$13.

To cut a straight or curved line, just score the surface with a sharp X-Acto knife, and bend the plastic at the line. It will snap cleanly. To cut a rectangular opening, score the outline, bend the line back and then forward. The plastic takes pencil lines and erasures well and cements together easily with acrylic solvent cement, which makes it ideal for scale-model work. The material becomes brittle after a number of years, but this is a minor disadvantage.

—Edward S. Koizumi, Oak Park, Ill.

Tapering on the jointer, revisited

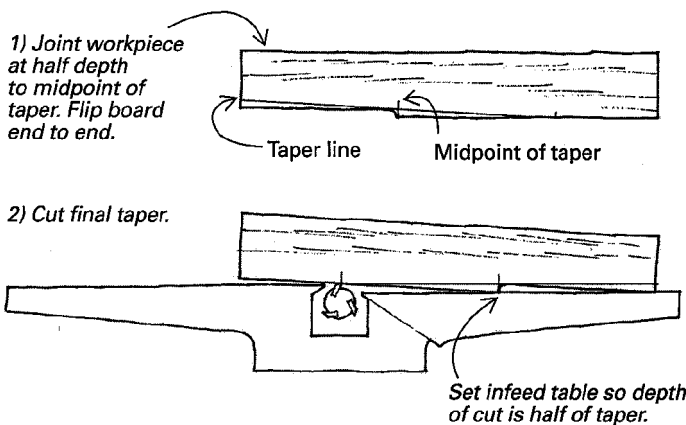

Here's another jointer-tapering method to add to those presented by Chris Becksvoort in *FWW* #112 (p. 32). First, make sure that the infeed and outfeed tables on your jointer are long enough to support the work the whole way through the taper. Second, your jointer should be heavy-duty, tuned and able to handle a hefty, 1/4-in. cut.

Draw the taper on the workpiece. Mark the midpoint of the taper, and set the jointer for half the depth of the taper. So if your taper is 1/2 in. over 22 in., you would set the jointer at 1/4 in., and mark the workpiece at 11 in. Push the end to be tapered into the cutterhead until the cut reaches the halfway mark on the piece. Re-

verse the workpiece, and with the two points resting on the infeed table, make another pass to cut the taper. Because of the heavy cut, push the workpiece through slowly and carefully. The results will be quite consistent from piece to piece.

—Edwin C. Hinkley, Provo, Utah

Using drill-bit shanks as depth gauges

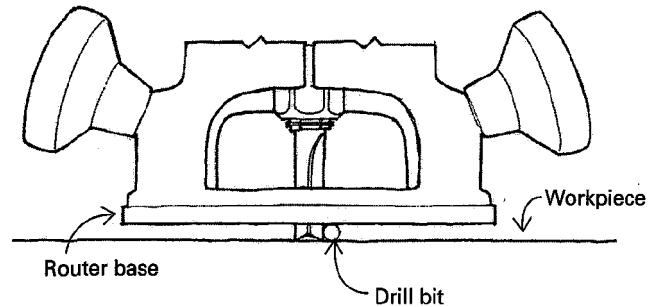

Twist-drill bit diameters are exact, so a drill laid on its side can be used to set a plunge router to an accurate depth. Put the bit on a flat surface, rest the router base on it, extend the cutter to touch the surface and lock the depth stop.—Percy Blandford, Stratford, England

Squaring the table on a disc sander

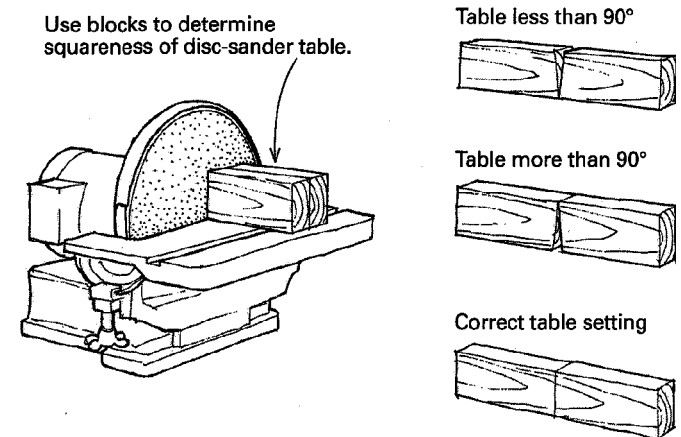

To get dead-square results from your disc sander, take a 2x4 about 1 ft. long, joint one edge and cut the block in half. After sanding the ends of the blocks, as shown in the drawing, bump both blocks together on a flat surface, end to end as they were originally. If there is a gap between the top of the blocks, the Sander's table is set at less than 90°. If there is a gap between the bottom of the blocks, the sander is set at more than 90°. Adjust the Sander's table, and repeat the process until you've removed any daylight from the joint.

—Kirt Kirkpatrick, Albuquerque, N.M.

Methods of Work buys readers' tips, jigs and tricks. Send details, sketches (we'll redraw them) and photos to *Methods of Work*, Fine Woodworking, P.O. Box 5506, Newtown, CT 06470-5506. We'll return only those contributions that include an SASE.

Jig for routing sliding dovetails in drawer fronts

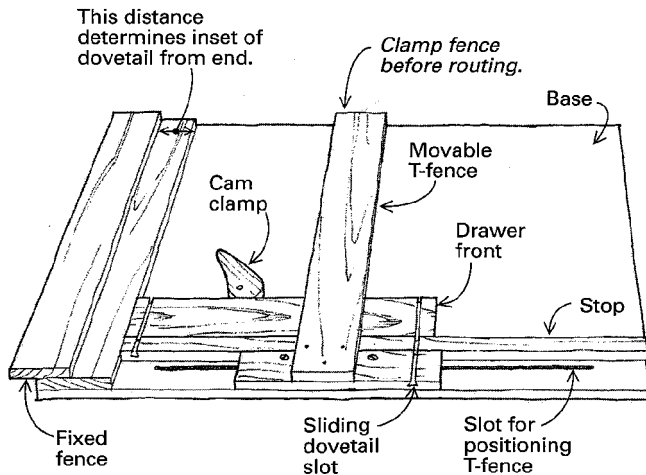

I recently received an order for drawers joined at the front with sliding dovetails. Because the drawers were of many different sizes, I needed to make a router jig that would accommodate drawer fronts of different lengths and widths. The jig I came up with consists of a base with a fixed fence on one edge and a movable T-fence on the other edge. The workpiece is aligned against a stop attached to the base at the front of the jig. The T-fence moves left and right to allow for various widths of drawer fronts, and it locks in place with bolts and wing nuts. I also clamp the T-fence front and back with C-clamps for extra rigidity. A cam clamp holds the work tightly against the stop.

To make through-sliding dovetails, clamp the workpiece in place, and rout both sides with the router. To make stopped-sliding dovetails, either make a stop or draw a stop line on the drawer front about 1/2 in. from the edge. —Robert S. Kummerow, Elmhurst, Ill.

Improved cabriole-leg pattern

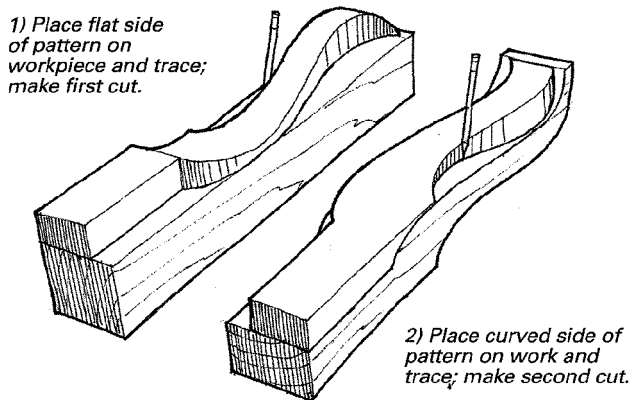

The way I mark and cut cabriole legs eliminates the need to save and reattach scrap pieces. The secret is to make a pattern that is flat on one side and curved to match the profile on the other. My pat-

tern is made of scrapwood, bandsawn and shaped with hand tools.

Place the flat side of the pattern down, and trace for the first cut. After sawing out the outline, rotate the stock 90°, and place the curved side of the pattern on the curved surface of the leg. Trace the profile of the leg, and make the second cut.

—Paul K. Murphy, San Jose, Calif.

Quick tip: When doing heavy work with a handplane or other hand tools, wear cyclist's gloves. The fingerless gloves allow for full dexterity, but the gel-filled pads protect the palms from blisters and bruising. —Broddie Newton, Richmond, Va.

Sawhorse with a vise

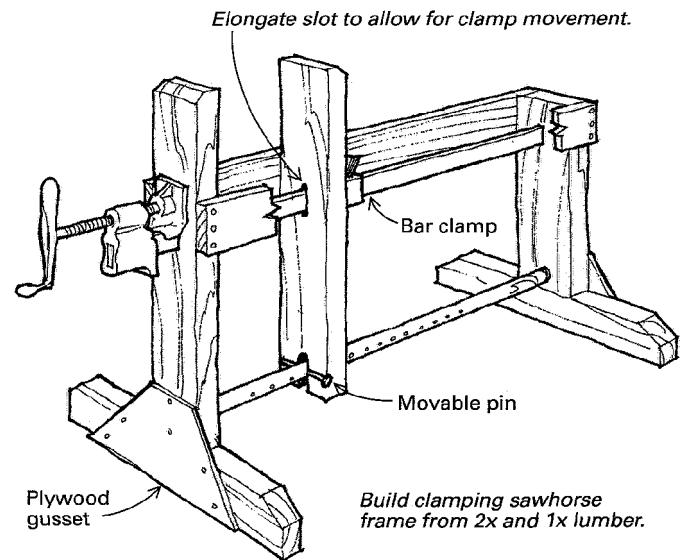

I use a wide variety of found wood for the turned objects I make. Collecting the wood is not as difficult as cutting it into suitably sized blanks for the lathe. The main problem is holding large and irregular pieces of wood safely while shaping them with a chainsaw. To solve this problem, I built this sawhorse/vise that uses an ordinary bar clamp to supply the clamping pressure. I have found it to be remarkably versatile and sturdy.

The two end supports have slots that cradle the bar clamp without pinching it. The mobile jaw has an elongated slot that allows the jaw to tilt to different angles as required by the irregular shape of the wood. The capacity of the jaw is adjusted using the pin on the lower bar and is limited only by the length of the bar clamp. I can easily slide the clamp out when I need it elsewhere.

—Neil Hendry, Gwelup, Perth, Western Australia.

Three-bath brush-cleaning system

I used to dread cleaning oil-based stains and finish from my brushes until a professional painter introduced me to his three-bath system. Here's how it works:

Fill three wide-mouthed bottles (48-oz. juice bottles work well) two-thirds full with solvent. Label them 1, 2 and 3. Put the dirty

brush in a tin can, and add the solvent from bottle 1. Clean the brush, wipe it with paper towels and pour the dirty solvent back into bottle 1. Repeat the process using the solvent from bottles 2 and 3.

Your brush should be nice and clean now, so reseal and store the solvent containers. Continue using this approach any time you clean a brush. When bottle 1 gets an inch or so of sludge in the bottom, carefully pour the remaining clean solvent into bottle 2, and relabel it 1. Change the label on bottle 3 to 2, and prepare a new bottle 3. This method is environmentally sound because you reuse the solvent.
—James W. Miller, Milan, Ill.

Folding sandpaper, revisited

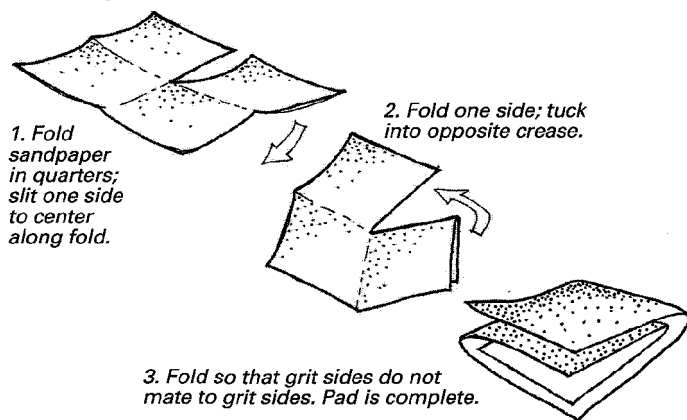

After seeing Peter Moffa's method for folding sandpaper in *FWW* #114 (p. 18), I wanted to share this solution that my father, a carpenter, showed me in 1940.

Take a sheet of sandpaper, fold and crease it in half in both directions as though preparing to cut quarter sheets. Cut along any crease, stopping at the center of the sheet. It does not take a rocket scientist to figure out how to fold the sheet so that you don't mate a grit side to a grit side.

—Rex Headland, Pasadena, Newfoundland

Catching glue squeeze-out with tape

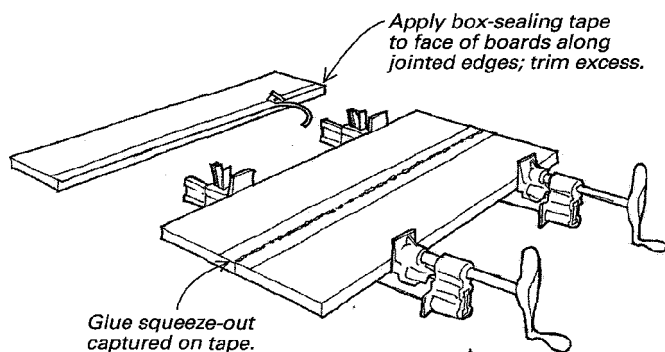

Here's a technique that keeps squeeze-out off the wood when you're gluing up panels. When the boards have been jointed, just before gluing, apply a strip of box-sealing tape on the face of each

board along the jointed edge. Let the tape overhang the jointed edges by 1/4 in. or so. Press the tape tightly along the corners. Then trim the overhang with a new safety razor, taking care not to nick the jointed edges. Glue as usual. Any glue squeeze-out will go onto the face of the tape and not onto your panel.

After the glue cures, remove the clamps, and pull the two pieces of tape off the joint. There may be a hairline bead of glue at the seam, but this is easily removed. Don't let the tape stay on the work too long because the adhesive may become hard to remove.

Exhaustive tests (not really, I just like the sound of that phrase) have determined that the best tape for this job is 3M's Scotch premium commercial box-sealing tape. Avoid using duct tape, masking tape, cheap packing tape or regular Scotch tape.

I much prefer spending the time applying tape than scraping glue residue, which can cause finishing problems. Taping also has the advantage of isolating clamp bars from the stock, thus eliminating iron stains.
—Jim Wright, Berkley, Mass.

Quick tip: To brighten your shop's work surface without adding one extra watt of light, paint the undersides of the cabinets or shelves that hang over your work areas with a light-reflective color. White or aluminum-silver are best. For even more reflectivity, tape aluminum foil or aluminum-faced insulation under these areas.

—R.B. Himes, Vienna, Ohio

Circular-saw cutting template

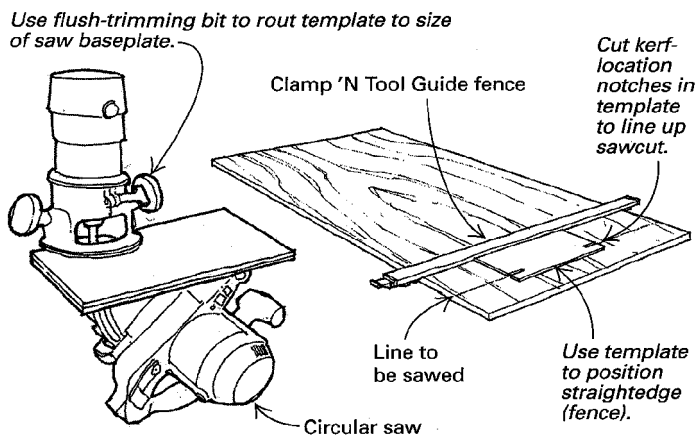

I often cut sheets of plywood with my circular saw, but it can be difficult to place a fence the correct distance from the cut line to guide the saw. To solve this problem, I made the template shown above. It's much easier to position a fence using the template than using the saw base.

To make the template, I clamped a 1/8-in. piece of hardboard to my saw's baseplate. Then I trimmed the hardboard to the exact size of the plate with a router and a flush-trimming bit. Using a saw, I ripped cuts in the front and rear of the template to show the location of the blade.

Now when I want to cut plywood, I just draw a pencil line where I want the cut and then align the fence (I use a Clamp 'N Tool Guide, made by Griset Industries; 800-662-2892). It's quick, and

it's easy to place the fence on either side of the cut with the kerf on the waste side of the line. —*Rasjad Lints, Vancouver, Wash.*

Improving tablesaw dust collection

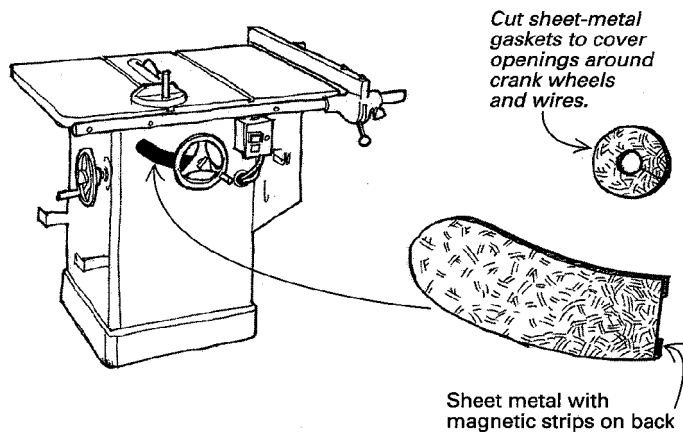

I wasn't getting enough suction at the sawblade on my Delta Uni-saw for efficient dust collection because of the large openings around the crank wheels and the switch wire. So I sealed the openings. I cut a scrap of sheet metal the same shape as the slot around the arbor-tilt wheel but 1/2 in. larger than the opening. I added some rubber magnetic strip (available at most craft-supply stores) to the outside edges so that I can remove the cover easily. I added sheet-metal gaskets to block other openings around the blade-height crank wheel and wire ports. —*Ted Asousa, Broomall, Pa.*

Lumber rack leans against a wall

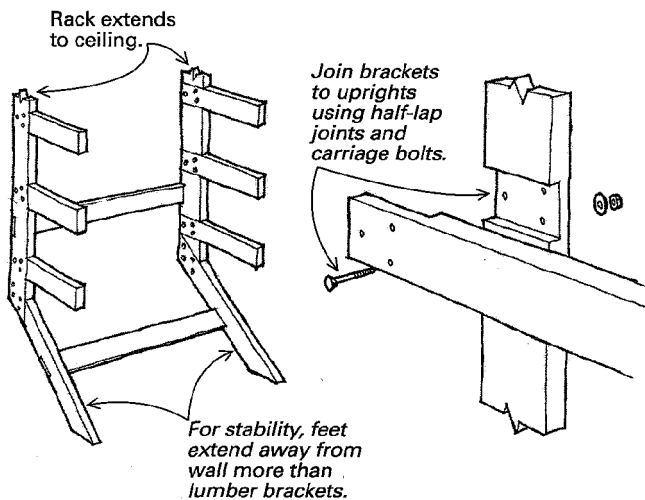

If you have to move frequently or you just like to reorganize your shop now and then, a portable lumber rack has merit. This rack is unique in that it leans against a wall and remains stable. The rack's feet are farther away from the wall than the end of the brackets, so

the load is counterbalanced. Even though the rack is fairly strong, don't overload it. It won't support as much weight as a post-and-spar lumber rack.

If you're concerned that the rack might kick out (though I've never had this problem), put non-skid pads on the bottom of the feet or tack them to the floor. If wall space is at a premium, you can make two racks and bolt them together back to back to form a freestanding unit.

I constructed the rack with 1-in.-thick, 3-in.-wide oak boards. Half-lap joints were used throughout, each reinforced with three or four carriage bolts. —*Gerald C. Lauchle, State College, Pa.*

Quick tip: When you are restoring older machines and you find that the nuts you have are smaller than the originals, ask a machine shop or industrial supplier for "heavy" nuts. Their threads fit the bolt, but the outside of the nuts are one size larger, both in width and in thickness. They're much easier to turn for repeated loosening and tightening. —*Craig Mooslin, Arcata, Calif.*

Cutting angles greater than 45° on a chop saw

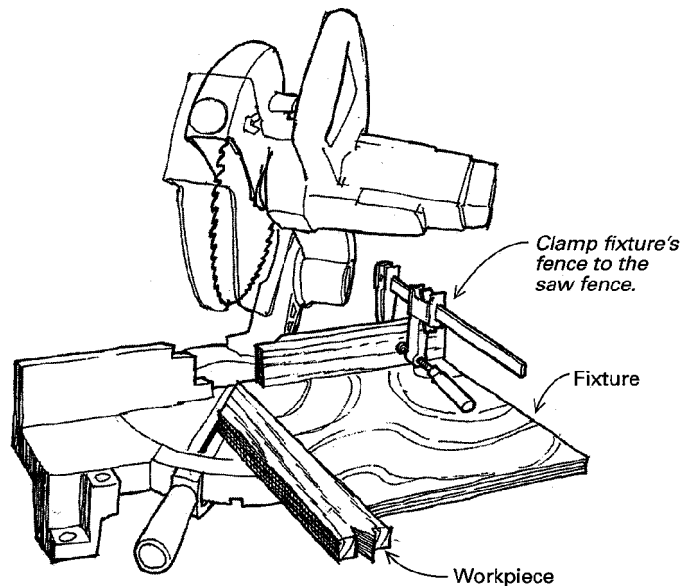

For a recent project, I needed to make 50° miter cuts, but my power miter saw cut only up to 47°. So to remedy that problem, I made a fixture that clamps to the main fence with the working edge 90° to the saw's original fence.

Now, to cut large angles, all I have to do is set the saw at the reciprocal of the angle (90° minus 50° gives a saw setting of 40°). When you cut angles more than 60°, it is a good idea to use a workpiece hold-down to keep your fingers away from the blade.

—*Richard A. Menin, Meadowbrook, Pa.*

Methods of Work buys readers' tips, jigs and tricks. Send details, sketches (we'll redraw them) and photos to *Methods of Work*, Fine Woodworking, P.O. Box 5506, Newtown, CT 06470-5506. We'll return only those contributions that include an SASE.

Threading wood without taps

Pilot hole should be just less than root diameter of bolt.

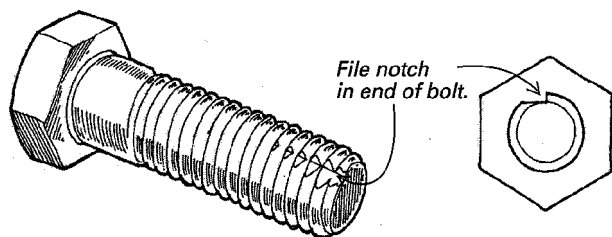

Use bolt to cut threads in wood.

I agree fully with Clyde Seitz's comments (*FWW*#113, p. 20) that T-nuts are not always needed. Threads tapped right into the wood are acceptably strong for most purposes. And you don't really need a tap to cut the threads. In softer woods like pine and spruce, just drill a pilot hole, and screw the bolt into it. The bolt threads will compress the wood. In hardwoods, simply file a notch into the end of the bolt, as shown. File the notch slightly into the threads, and drill the pilot hole a little smaller than the bolt diameter so that some compression occurs. I have done this for many years in jigs and fixtures without any failed threads.

—Fred Reeves, Cambridge, Ont, Canada

Quick tip: A hot-melt glue gun is useful for making temporary attachments, such as workpieces to templates. But then these pieces must be separated. A few drops of acetone will make the glue loosen the glue's grip.

—Milliard Stone, Irving, Texas

Determining grain direction for handplaning

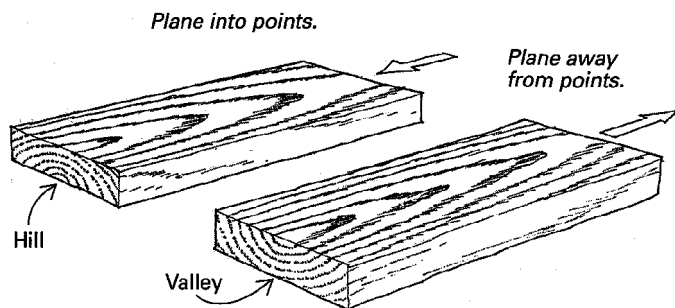

When handplaning boards, it is sometimes hard to know which direction to choose to avoid tearout. Checking the grain on the side of the board is a help, but that doesn't always tell the whole story. Here is an additional method that works very well.

Look at the end grain of the board. With flatsawn lumber, you get one of two patterns: hills or valleys. Then look at the surface of the wood to see where the grain forms rounded points (called cathedrals). If the end grain is a hill, plane into the points. If the end grain is a valley, plane away from the points.

To help me remember the somewhat complicated directions, I think of an imaginary battle where a band of warriors charge up the hill and into the points of their enemy. The warriors retreat and run back into the valley with the enemy's points at their backs.

—Billy King, Oldhams, Va.

Quick tip: To hold oddly shaped items while drilling, put several handfuls of small dry beans in a heavy-duty resealable plastic bag. Put the bean bag on the drill-press table, and place the part to be drilled on top of it. Press down so the beans conform around and support the part. When the bag wears out, just drop the beans into a new bag, and you're back in business.—R.B. Himes, Vienna, Ohio

Improved miter-slot runners

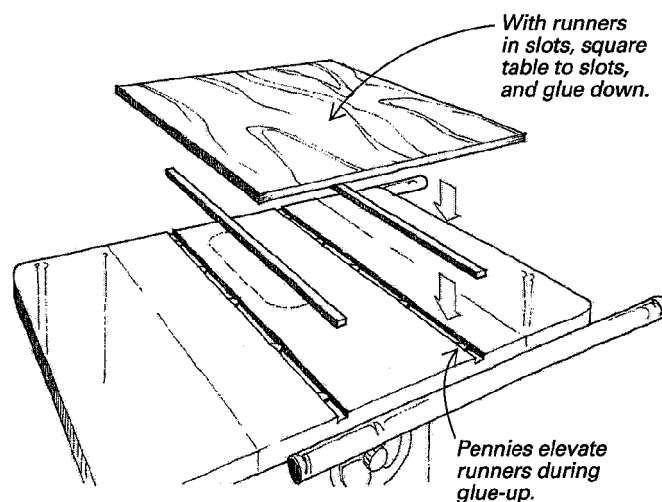

As anyone who has ever tried to make a sliding table for a table-saw knows, aligning the runners to the sliding table correctly can be frustrating. The trick is to do it in place. This drastically simplifies the process and virtually ensures a perfect fit and smooth sliding action.

First cut and fit runners for the miter-gauge slots. Make the runners a little shorter than the total length of the slot and slightly thinner than the depth of the slot. The runners should be hardwood (red oak or hard maple is a good choice). Sand or plane the runners until they move freely but snugly. The runner size typically will be $\frac{3}{4}$ in. wide by a little less than $\frac{3}{8}$ in. thick. The runners should not touch the bottom of the slots when the table is finished.

Attach the sliding table to the runners. The runners should be elevated until they are just proud of the table surface. I use pennies. I evenly distribute four or five stacks of two pennies along the bottom of each slot to raise the runners.

Align the ends of the runners with the front ends of the slots, and shim or wedge the runners to force them to the edge of the miter slot closest to the blade. This removes any remaining slop. Apply glue to the top of the runners, and carefully set the sliding table on top, aligning the front edge of the table at 90° to the miter slots. Finally, add weight to the top of the table over the runners for a good glue bond. I generally use a good stack of bricks.

After the glue has cured, remove the sliding table, pennies and shims from the saw. For insurance, screw the runners to the table

from below, countersinking the heads. Apply a coat or two of paste wax to the table bottom and runners, and you'll be in sliding heaven.

—Mike Smith, Smyrna, Ga.

Erasable pattern material

Sign shops have a product very useful to woodworkers—a rigid plastic board made from expanded PVC foam. The board is excellent for drawing patterns and making full-sized layouts. You can shape it easily with woodworking tools, trace around it repeatedly without wear, draw and erase pencil lines on it, and even use it for a router guide. You can glue directly on it because glue does not stick to it. The brand of board I use is Trovical. A 1/8-in.-thick, 4x8 sheet costs approximately \$40.

—Peter LaMontagne, New Britain, Pa.

Handsaw cabinet

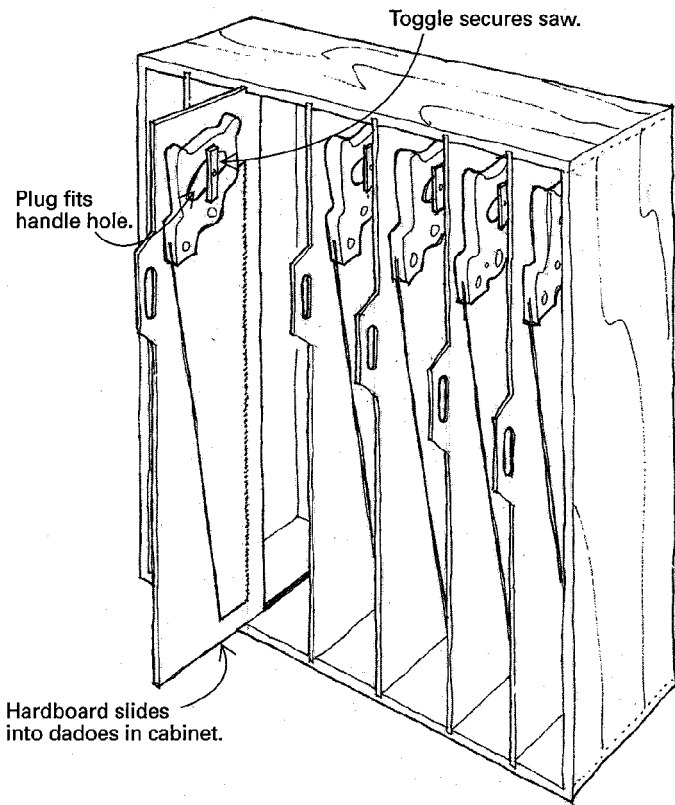

Storage of handsaws is always a problem, especially when your shop is as small as mine. So I designed this space-saving cabinet that has hardboard slides to hold the saws. I constructed the carcase of the cabinet from 5/8-in. plywood and the back and saw slides from 3/16-in. hardboard. Each saw rests on a custom-shaped 1 1/4-in.-thick plywood block that fits the space inside the saw handle. I added a small hardwood toggle to hold the saw in place.

The dimensions of the cabinet vary according to the number of saws you have and their length and width. In my case, I sized the cabinet about 32 in. tall, 8 in. deep and 14 in. wide, which gives space for six saw slides, each spaced about 2 in. apart.

—Adam van Sertima, Montreal, Que., Canada

Making discs on the router table

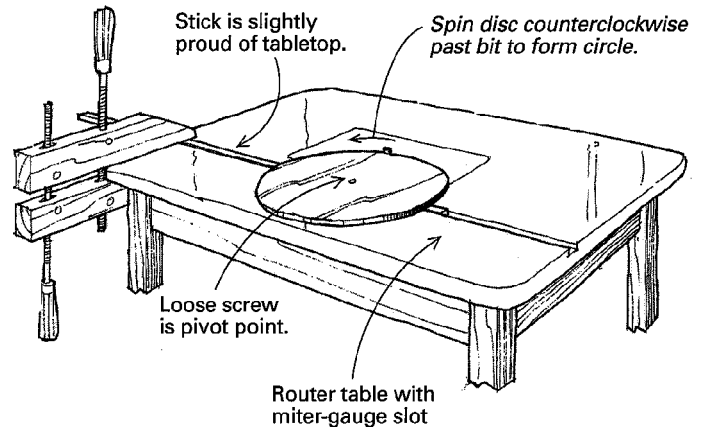

To cut smooth, accurate circles, make a sliding wooden strip to fit in the miter-gauge slot of your router table. The strip should protrude just slightly above the surface of the table so a clamp will hold it in place. Put a screw through the center of the workpiece into the wood strip. The screw should be just loose enough so the work will rotate. The screw can be driven up through the strip and into the bottom of the work if you don't want a visible hole. Turn the piece counterclockwise to make the cut. Slide the strip right or left to adjust the radius. The size of the disc can range from 8 in. or so to about 24 in., depending on the router table.

—Tom Rausenberg, Dayton, Ohio

Quick tip: I use a towel under my waterstones to pick up all the muck and slurry generated by the sharpening process. One day, I used this muck-permeated rag to wipe a rusty square and was amazed to find that it polished the blade with very little effort. Now whenever rust appears on my metal tools, I remove it with a few quick rubs of my muddy rag. —Ben Thompson, Montezuma, N.M.

Using Quick-Grip bar clamps as hold-downs

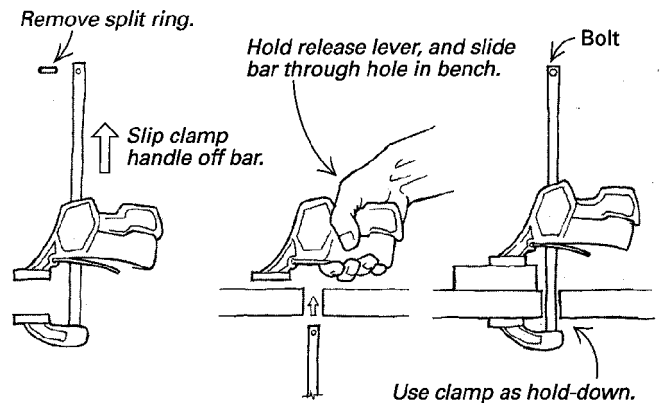

Here's how to use a Quick-Grip bar clamp as a hold-down: Locate the bench-dog hole where you want to position the hold-down, or drill a 3/4-in. hole through the benchtop. Now punch out the split ring on the end of the bar, hold down the release lever of the pis-

tol grip and slide the grip assembly off the bar. Don't let go of the release lever, or you will have to realign the retention washers and spring inside the grip. Guide the bar through the hole in the bench, and slide the grip assembly back onto the bar. Replace the split ring with a 1/4-in. bolt and wing nut to facilitate future changeovers.

—Matt Valikoski, Campbell River, B.C., Canada

Web-clamp work holder

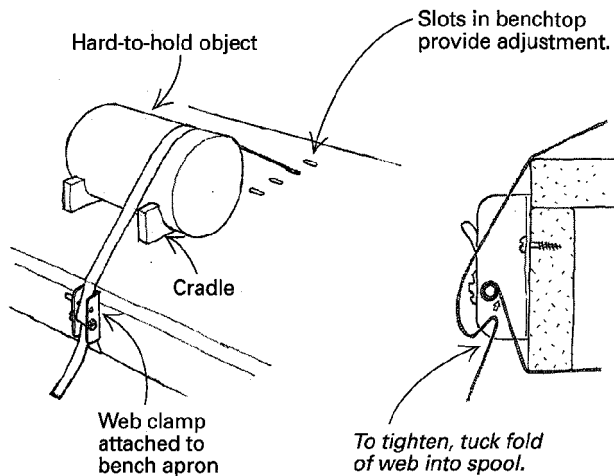

Because of their size and shape, the musical instruments I build are difficult to hold securely on the workbench for carving and routing. So I use this simple web-clamp system to hold instruments, or any other oddly shaped object, quite securely. Screw two or more web clamps to the apron of your workbench, as shown in the sketch. When you need to secure a workpiece, grab the loose end of the web strap, thread it from below through one of several pre-cut slots in your bench, bring the strap up over the workpiece and back to the clamp. Now stick a fold of the web into the spool so that it is caught by the wrap around the tightening axle. Then tighten the clamp to secure the workpiece. If necessary, make a cradle, as shown, to hold the object. —Jeffrey Lee Gaynor, Rootstown, Ohio

Repeatable divider settings

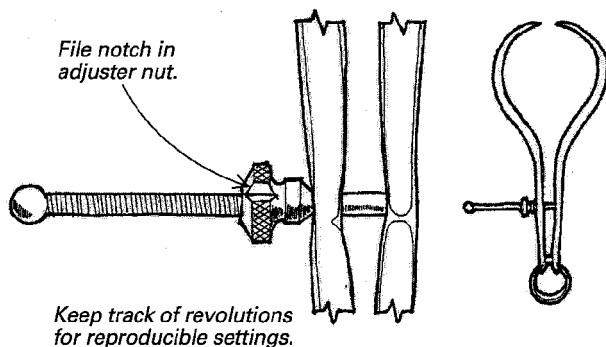

Calipers and dividers are great when you want to gauge a thickness, such as the wall of a turned bowl. But because there are no calibrations on many of these tools, it's difficult to repeat settings.

You have to transfer distances to wood or read the measurement against a scale. A simple solution is to file a notch into the adjuster nut so that you can keep track of the number of turns. Because the threads are fine, returning the nut to an exact position will reset the calipers to a previous position with great precision.

Put the dividers in place, and tighten the nut until the tips of the dividers touch the material you're gauging. Now back off the dividers. Count the number of revolutions by watching the notch. Remove the dividers from the work, and return the dividers to their original position by counting revolutions of the nut.

—George R. Estano, Braintree, Mass.

Quick tip: While cleaning my shop, I happened upon a hardened tube of silicon caulk. I removed the rubbery plug from the tube and discovered, after pressing the silicon against the running belt of my sander, that it cleans the belt every bit as well as the commercial rubber bar made for that purpose.

—Dwayne Roeder, Skamania, Wash.

Ellipse drawing aid

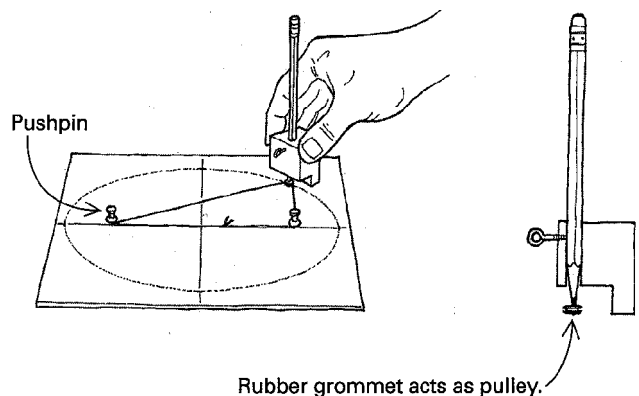

Here's a simple little device that makes drawing an ellipse easier and more accurate. To lay out the ellipse, first draw the vertical and horizontal dimensions of the ellipse on a pattern board. Now drive two pushpins into the pattern material along the long axis of the ellipse. Tie a loop of string loosely around the pins, as shown. After some trial and error, you should be able to vary the position of the pushpins and the length of the loop so that the string, when taut, touches the vertical and horizontal dimensions of the ellipse.

Now you're ready to use the drawing device. Mount a pencil in the device, catch the pencil in the loop and, keeping the loop taut, trace the circumference to draw the ellipse. The device will keep the pencil perpendicular to the paper, which is hard to do without assistance. Use a screw eye to lock the pencil at the right height. To keep the string taut and down near the surface, place a small rubber grommet, available from auto-parts stores, on the tip of the pencil. The string will ride in the groove of the grommet as you move the pencil.

—Robert J. Gabor, Pittsboro, N. C.

Methods of Work buys readers' tips, jigs and tricks. Send details, sketches (we'll redraw them) and photos to *Methods of Work*, Fine Woodworking, P.O. Box 5506, Newtown, CT 06470-5506. We'll return only those contributions that include an SASE.

Another way to taper on the jointer

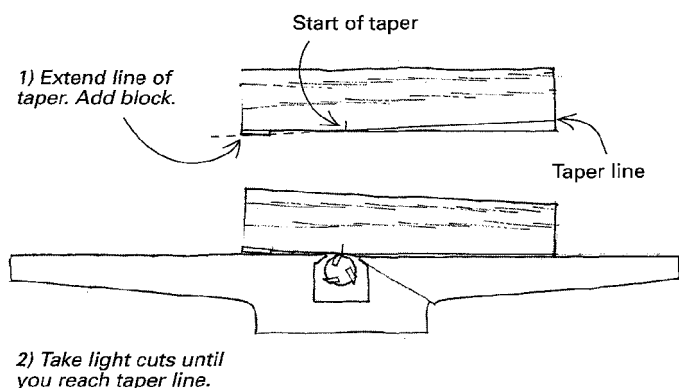

If you want to cut leg tapers on the jointer without fuss and adjustments, all you really need is a small block of 1/4-in. or 1/2-in. plywood. Lay out the taper on the leg, and with a straightedge, extend a line beyond the start of the taper. The line will be off the stock. Position the block on the leg so that the corner of the block touches the extended taper line. You can tack the block in place with hot glue.

Before jointing, take a trial pass to make sure the block doesn't fall off the bed at the end of the cut. Now place the leg on the jointer with the block on the outfeed table (past the cutterhead) and the taper start line over the cutterhead. Push the leg through the cutter and repeat, taking light cuts until you reach your line.

—Dick Tuttle, Marietta, Ohio

remove the clamps and the tape. Sometimes the masking tape will pull away small strips of veneer, so use caution. I've discovered that Anchor brand tape leaves less residue and is easier to remove than other brands of masking tape. To complete the veneered column, put it in the lathe for sanding and finishing.

—Vern Ziebart, Rapid City, S.D.

Plywood cutoff aid

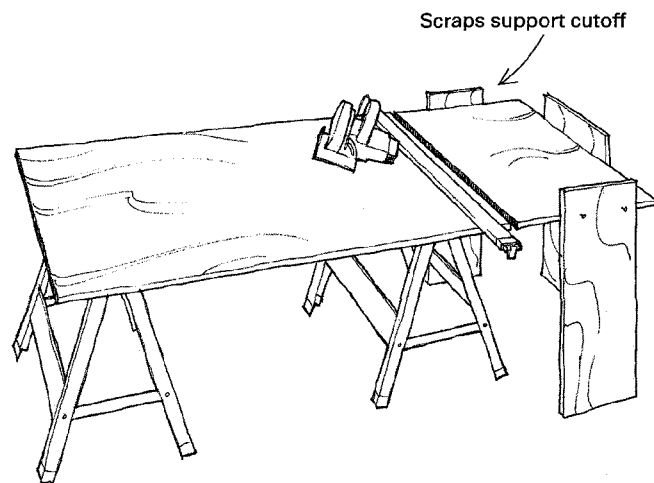

It is often easier to cut large sheets of plywood with an edge guide and a portable circular saw than to wrestle the sheet onto the tablesaw. To support the piece being cut off, tack two or three scraps to the edge of the piece, as shown, to serve as legs.

—Thomas Broderick, Tallmadge, Ohio

Veneering columns

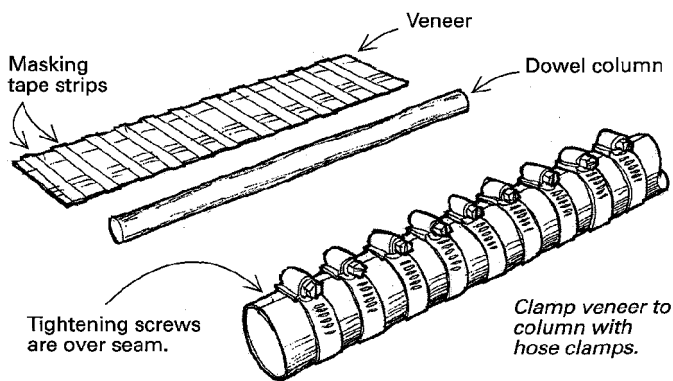

I use columns veneered with crotch mahogany and other exotic woods on the grandfather clocks I build. The veneer is strengthened with strips of masking tape every 3 or 4 in. and then wrapped around a glue-coated dowel. I hold the veneer in place temporarily with masking tape or veneer tape. Radiator clamps slip in place with the tightening part of the clamp over the veneer seam. Normally, you can space the clamps about 1/2 in. apart, but some veneers may require closer clamp spacing. When the glue has set, I

Edging plywood

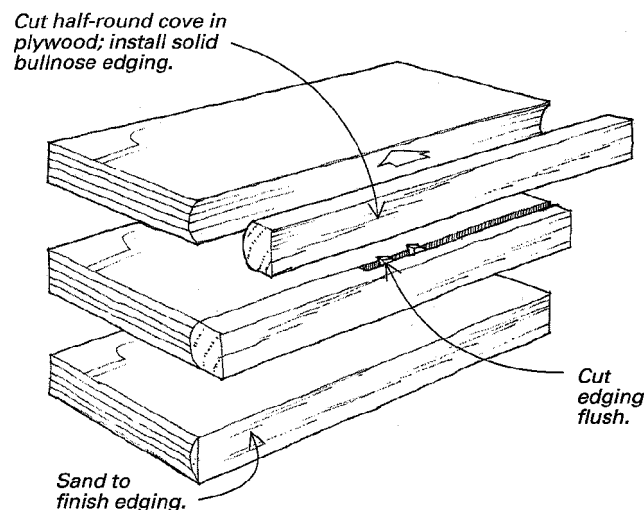

Most of my cabinetry includes doors and drawer fronts made of plywood. I refuse to use veneer tape to cover raw edges, and solid edging, which I used for a while, is too conspicuous. So I came

up with edging that's strong, easy to set up and nearly invisible.

Start by installing a 1-in. half-round flute cutter in the shaper, centered precisely on the plywood stock. Adjust the depth of cut to produce almost, but not quite, a feather edge on the top and bottom edges of the plywood, as shown in the sketch on p. 12. There should be just enough flat left after the cut to support the edge against the outfeed fence. The fluted edges are not quite as delicate as they look, but they do require careful handling.

There is usually a plentiful supply of solid hardwood edging in the scrap bin. Install a 1-in. half-round bullnose cutter in the shaper. Center the cutter on the stock, and adjust the outfeed fence to the finished cut. If you prefer, bullnose both edges of the hardwood, so you can glue up two plywood blanks at once.

Glue and clamp the edging in the flute of the plywood panel. Or, if you bullnosed both sides of the edging, sandwich it in the flutes between two plywood blanks. After the glue sets, separate the plywood blanks by ripping the edge piece. Leave a little extra—this is not the final cut. Trim any tails, and dress the face to final thickness. With a sanding block, slightly round over the edges. The last step eliminates the slight groove between the plywood and the edge trim.

—Max Whitaker, Silverton, Ore.

Quick tip: An extremely effective and durable bag for vacuum veneering can be improvised from a waterproof storage bag used for kayaking and white-water rafting. The bags are heavy-duty plastic and have excellent closure systems that are airtight. They can be modified for veneering by adapting the air tube (used for blowing up the bag) to fit the pump hose.

—Mark Moffatt, Denver, Colo.

Kaleidoscope patterns in wood

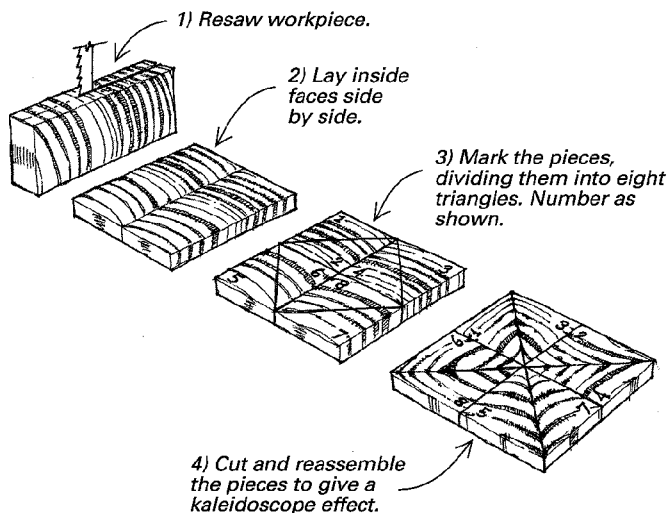

I've been making book-matched boxes ever since reading about them back in 1982 (FWW #32, p. 14). I've wondered about other ways to create grain patterns. Recently, I tried a variation that produces interesting kaleidoscope-like designs.

First resaw your stock in half, and cut the pieces in two to form square quarters. Split each square along the diagonal, as shown.

(A thin-kerf blade in a miter saw works well for this step.) Recombine the pieces using the numbering shown in the sketch. The more complicated the grain of the original pieces, the more interesting the result. No matter how wild the grain, a perfectly matched pattern will result.

—W. Esser, Los Angeles, Calif.

Jig cuts slots for corner splines

Mount jig to router-table fence.

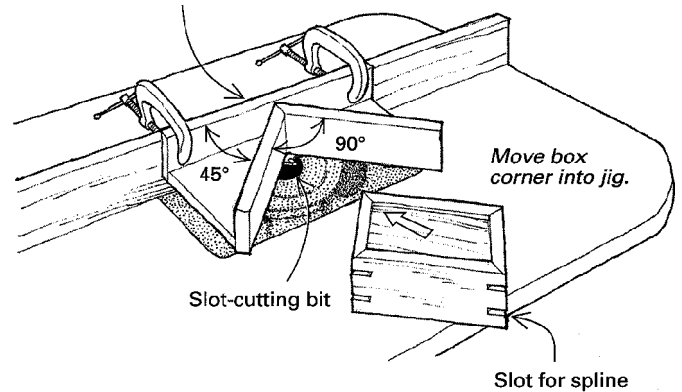

A commission for six identical boxes led me to develop this router-table jig for cutting spline mortises in outside corners. The jig is used with a slot-cutting bit. To make the jig, mount two 1x3s joined at a right angle to a backing board at a 45° angle. Clamp the backing board to the router-table fence so that the jig is directly above the bit. Adjust the fence in or out to get the right spline depth. To cut the slot, guide the box corner into the jig until it stops at the vertex. Using the jig, I cut 48 slots in less than 10 minutes.

—Mark Maiocco, Spotsylvania, Va.

A work holder that swivels

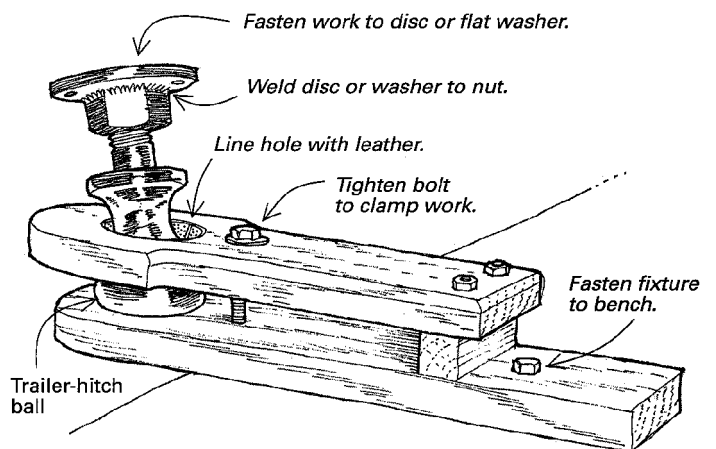

I recently needed a swivel-type work holder—the kind carvers use. Because the price for a commercial holder was about \$125, I decided to make my own with a trailer-hitch ball and some shop

scraps, as shown on p. 14. The fixture is simply two pieces of hardwood that lock the hitch ball in place when a bolt is tightened. Line the hole in the top board with leather so it will grip better. For the workpiece plate, weld a large washer or disc to the nut, or attach it with screws tapped into holes in the nut.

—Harry J. Gurney, Taunton, Mass.

Quick tip: Shave buildup off the cutting edges of your router bits with a disposable razor, and then wipe the bits clean with turpentine. If you do this each time you use your router, you'll get cleaner cuts and prolong the life of your bits.

—Wells Mason, Austin, Texas

Drilling long holes with gun drills

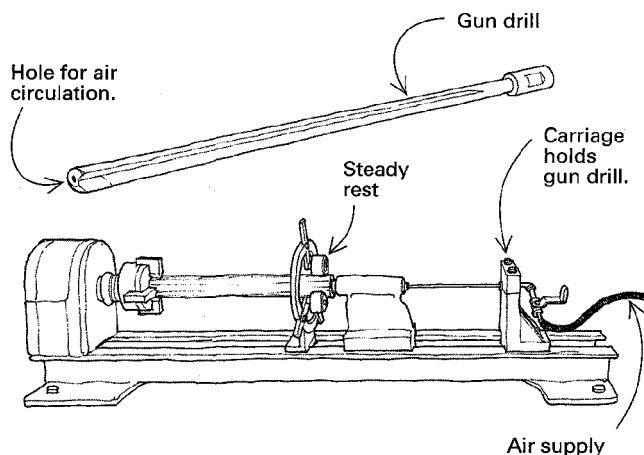

Chris Becksvoort's answer to the long-hole end-grain drilling question (*FWW* #116, p. 26) is right on target for woodworkers who do this occasionally. But if you are doing production drilling of long holes, a gun drill is the way to go. Gun drills are special bits made for drilling steel gun barrels. They are available in several lengths and diameters useful to woodworkers. One source is Danjon Manufacturing Corporation (1075 S. Main St., P.O. Box 212, Cheshire, CT 06410-0212; 203-272-7258).

The cutting edge of the gun drill uses a scraping action that will not wander in end grain. The most useful feature of the gun drill, however, is a hollow shank that permits the flow of pressurized air into the cutting area. The flow of air flushes out chips, allowing uninterrupted boring of smooth, precise holes.

I hold the drill shank in a carriage that slides on the lathe ways. The bit goes through a special hollow in the tailstock, dead center into the wood. I pump 100 psi pressure into the drill, and use a steady rest made by Andrew Shimanoff Tool Design (P.O. Box 1318, Ashland, OR 97520; 514-488-3059) to support the blank on the out-board end. With this setup, I can bore a 3/16-in.-dia., 15-in.-long hole in extremely hard wood, like African blackwood, in about 90 seconds. The bits are expensive, but drilling holes does not get any faster or more accurate than this.

—Michael A. Dow, York, Maine

Quick tip: To clean up shavings after drilling, filing or machining steel, place a plastic bag, inside out, over a magnet. Attract the shav-

ings with the magnet, and turn the bag right-side out. The shavings will be neatly contained in the bag.

—Alan L. Garst, Salem, Va.

Collecting bandsaw-table dust

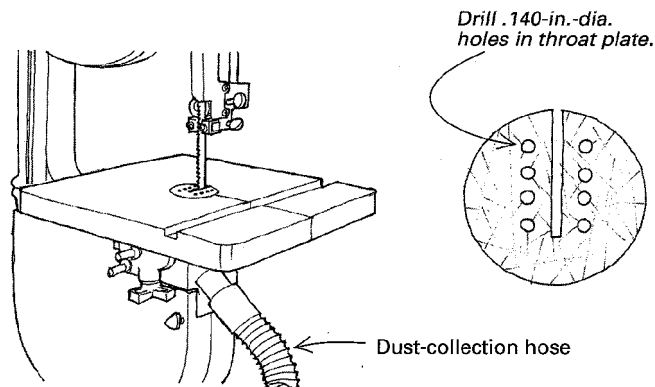

My bandsaw is equipped with a hose attachment to collect sawdust. But the space between the throat plate and the blade is so small that dust collection is not very efficient. I tried removing the aluminum throat plate. That helped, but offcuts would often fall into the gap and jam the blade. To overcome this, I drilled holes in the throat plate. Now the dust is collected efficiently, and the offcuts don't jam.

—Gil Warmbrodt, St. Louis, Mo.

Router mortising jig

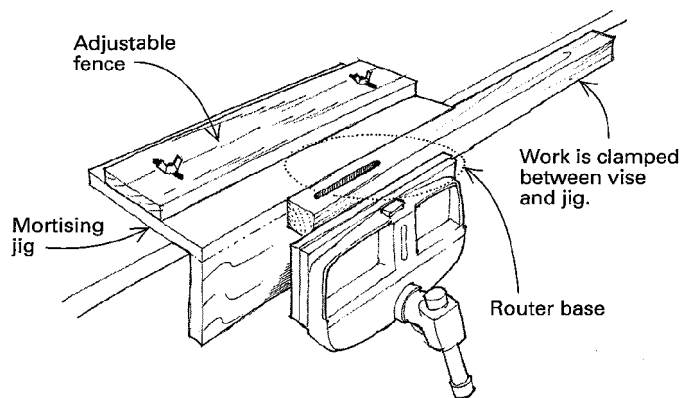

With this simple jig and a plunge router, you can rout mortises or panel grooves in any size leg or rail. The work is held between the jig and your bench vise, clamped flush with the surface of the jig. The jig provides a stable base for the router. Adjust the fence back or forth to orient the router cut to the workpiece. For longer pieces, make a longer jig, and clamp the workpiece at each end.

—Anthony Guidice, St. Louis, Mo.

Methods of Work buys readers' tips, jigs and tricks. Send details, sketches (we'll redraw them) and photos to *Methods of Work*, Fine Woodworking, P.O. Box 5506, Newtown, CT 06470-5506. We'll return only those contributions that include an SASE.

Sandpaper cutting fixture revisited

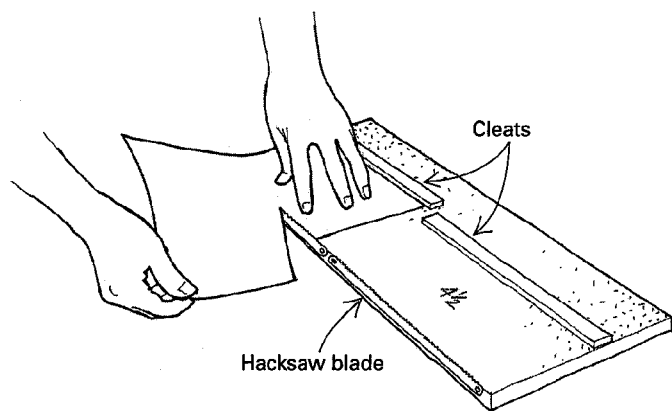

Here's a sandpaper cutting fixture that is similar to the one presented by Anthony Guidice (*FWW*#116, p. 14). It has a few refinements that make it quicker to use and more versatile. Take a piece of scrap plywood, approximately 10 in. by 24 in., and screw down two cleats about 12 in. long, as shown in the sketch. One cleat should be 4½ in. from the edge and the other 5½ in. This allows you to cut a piece of sandpaper in two either horizontally or vertically. Now screw a used hacksaw blade opposite each cleat along the edge of the plywood with the teeth slightly over the edge.

To use, let the fixture hang over the edge of your workbench. Butt the sheet of sandpaper against the 4½-in. cleat, hold the sandpaper in place with one hand and tear down with the other. The sandpaper will be torn accurately into a half-sheet that's ready for use. To make a quarter-sheet for most palm sanders, tear again with the paper butted against the 5½-in. cleat.

—Lee Holdren, Bellevue, Wash.

Bending wood with a clothes iron

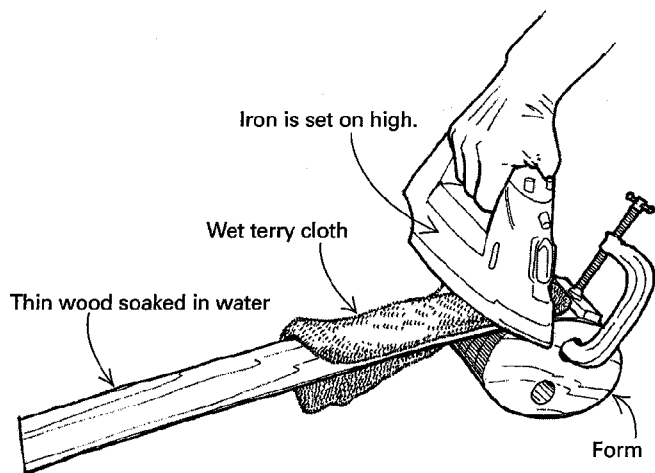

You can use any one of several methods to bend thin wood for bent-wood boxes. But things get more difficult with thicker material (about ¾ in.). Recently, I found a way to bend thicker stock using an ordinary clothes iron, eliminating the need for a steambox.

Start by soaking the wood overnight in water. Clamp it to your

form, place a wet terry cloth over the wood and, using a clothes iron set on high, iron the wood around the form. The iron will force steam into the wood. Keep the cloth wet, take your time and concentrate on getting the shape right. As you bend the piece around the form, the wash cloth and the iron act as a caul to prevent tearout of the outer fibers. —Gary H. Johnson, Dalton, Ga.

No-space drying racks

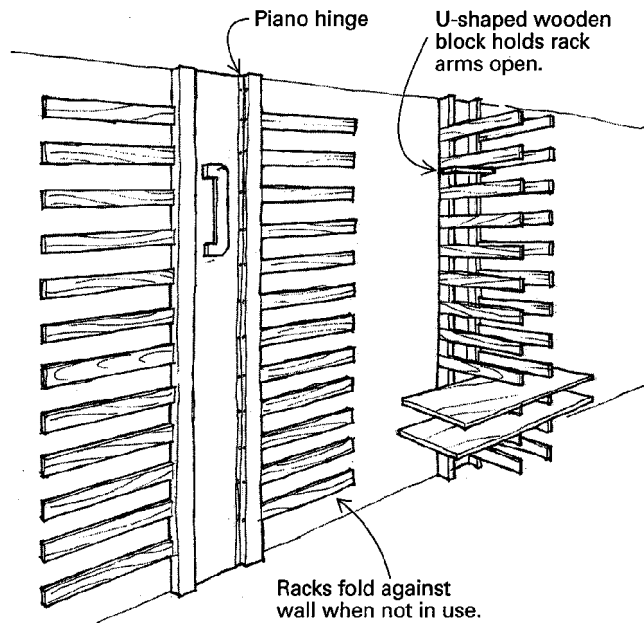

The advantage of these drying racks is that they lie flat against the wall when not in use, so they occupy none of your shop's valuable real estate. The racks consist of two comb-like arms that pivot on piano hinges. A U-shaped wooden block fits over the arms and locks them in the drying position. Two racks, side by side, can hold long workpieces.

—Michael Dugan, Bohemia, N.Y.

Fastening a tabletop

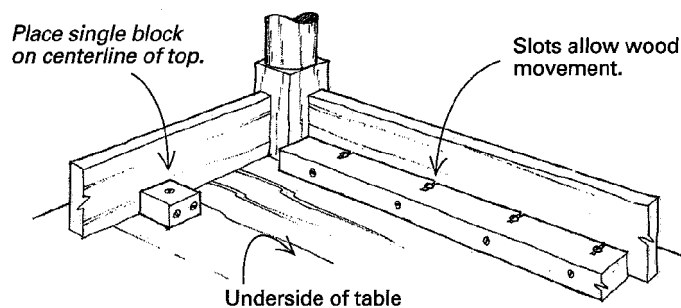

This tabletop fastening technique is quick, convenient and looks better than buttons or clips. Cut 1-in.-thick wood strips, and screw the strips into both the table apron and top, as shown. Use two fastening approaches to accommodate wood movement. On the

ends of the table, use short blocks rigidly screwed to the centerline of the tabletop. On the sides of the table, use longer strips slotted with a series of 1/2-in.-deep sawcuts. Screw the strips to the apron rails, and then attach the top with pan-head, sheet-metal screws inserted about the midpoint of the slot. Don't cinch these screws down. They should be loose enough to move when the top expands and contracts. —Walter L. Owens, Bloomington, Ind.

Wall-hung battery chargers

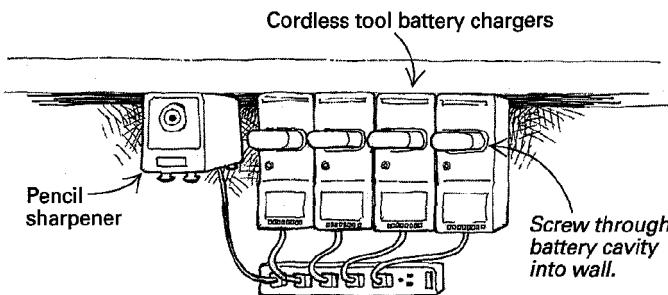

When I finally got tired of my bank of battery chargers taking up benchtop space, I hung them on the wall below a cabinet. This arrangement frees up your workspace, prevents dust from settling inside the chargers, allows one-handed battery insertion and puts the indicator lights where I can see them.

Before mounting a charger to the wall, remove the baseplate to make sure you're not drilling through anything electric. Pilot and countersink screw holes through the charging cavity for proper battery seating. The arrangement works so well I added an electric pencil sharpener next to the bank. —K. Hertik, Bohemia, N.Y.

Making crowned caul strips

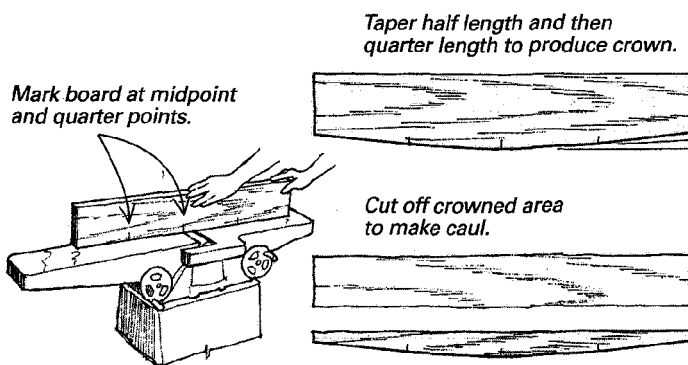

When you need to glue solid-wood edging to plywood, a crowned caul will let you do the job with a minimum of clamps. Properly made, the caul will apply consistent pressure along its length when a clamp is applied to each end. Cutting the subtle curve in the caul can be tricky, though. Here's how to do it simply and quickly on your jointer.

Select a springy, tough wood like ash. Cut a piece as long as you want the caul and about 6 in. wide. Make sure both edges are par-

allel. Visualize the amount of crown you want, say, 1/4 in. over a 3-ft. length. Set the jointer to cut half this depth, 1/8 in. in this example. Divide one edge of the workpiece in half and that space in half again to give four equal sections along the length. Mark a pencil line at these divisions on both sides of one edge.

To cut the crown, use the jointer to cut four tapers on the workpiece: two one-half the length and two one-fourth the length. Place the workpiece on the jointer with the middle line on the outfeed table right behind the cutter, and push through. The jointer will take a progressively deeper cut to taper half the workpiece at 1/8 in. Now repeat this tapering process starting at the one-fourth division line. This will cut another 1/8-in. taper but only on the last quarter of the workpiece. Reverse the workpiece, and repeat the process to cut two tapers on the other end. The result will be a crown that is 1/4 in. proud of the ends. Take the workpiece to the tablesaw, and rip from 1 in. to 2 in. off the crowned edge to produce the caul. The thicker the caul, the more pressure it will apply.

—Jim Richey, Katy, Texas

EDITORS NOTE: The method above was inspired by a submission sent in by Caleb Carlson of Sandpoint, Idaho.

Quick tip: Dried out masking tape often can be renewed by putting it in a microwave oven for 10 to 15 seconds.

—Robert M. Vaughan, Roanoke, Va.

Stone hook

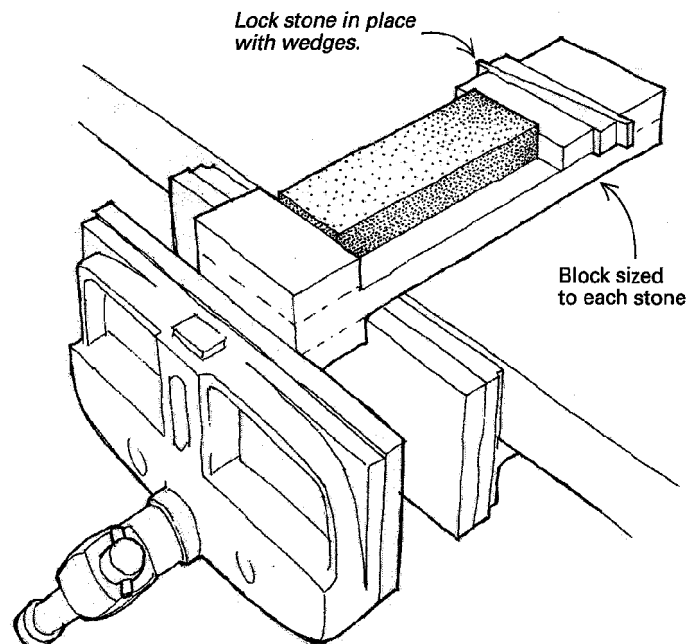

For years, I have collected sharpening stones from yard sales and happily used them in my workshop. Because no two stones are the same size, I built a simple device that I can adapt to hold stones of different length and width. I call it a stone hook, and the design

is based on a bench hook. The device is a simple wooden block fitted with a fence at each end. A pair of wedges lock the stones into the block against a spacer piece sized for each stone. Wedge the stone into the block, and then clamp the block onto the workbench with the bench vise. —James Scalone, San Diego, Calif.

Using Quick-Grip bar clamps as brad setters

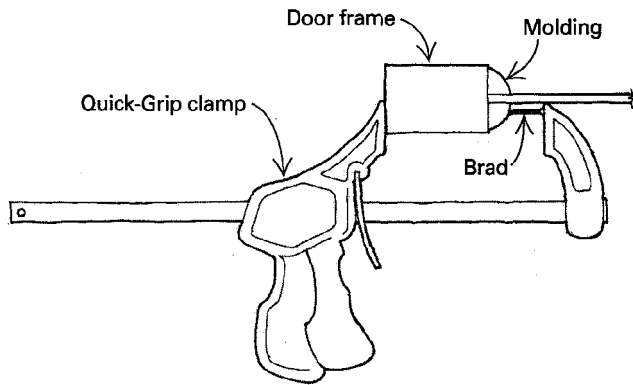

For setting the brads in the back of a picture frame or securing the glass-retaining molding in a display cabinet, try a Mini Quick-Grip bar clamp.

Remove the outboard jaw protector, and then press the brad into place by squeezing the pistol grip. Drill pilot holes for the brads to prevent splitting. This method is much better than trying to tap the brads into place with a hammer, where one errant blow can shatter the glass. —John Adams, Maumelle, Ark.

Easy-to-reach Unisaw switch

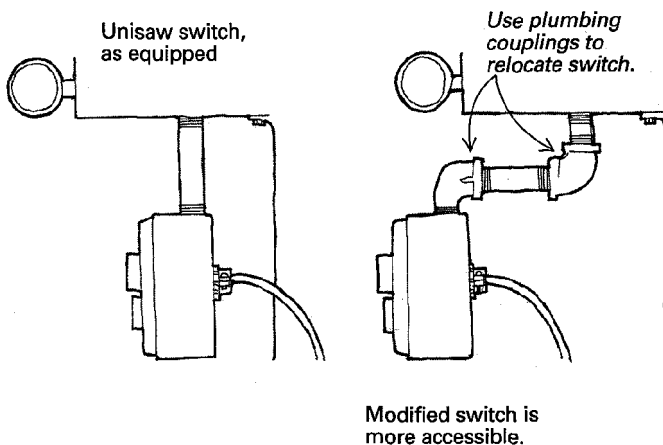

Here is a simple modification I made to my Delta Unisaw that provides much better access to the on/off switch. The factory-delivered Unisaw has its switch suspended below the table on a 5/8-in. by 4-in. pipe nipple. One end of the nipple screws into the bottom of the saw's cast-iron table, the other into the switch housing. To start or stop the saw, you must grope under the table and back about 8 in. from the edge.

By adding several elbows and a 1-in. nipple, I brought the switch

near the front of the saw where it's plainly visible and accessible. The wire doesn't go through the pipe, so there's no wiring change.

—Ron Kent, Kailua, Hawaii

Making multipaned windows

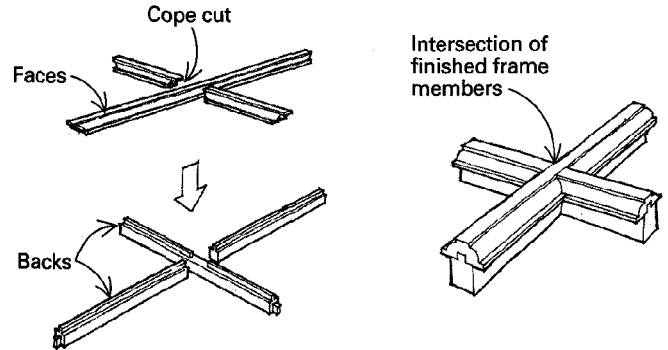

This is a way to use commonly available matched stile-and-rail router bits to simplify the complex joinery in multipaned windows. The key is to make up the frame parts in two pieces: faces and backs. Shape the faces with the stile-and-rail bits, making cope cuts for the joints where face pieces intersect. Cut and shape the back pieces on the tablesaw. Now glue the faces to the backs, interlocking the butt joints to produce a strong and straight frame.

—Yves Barbaroux, La Varenne Saint Hilaire, France

Shopmade bandsaw fence

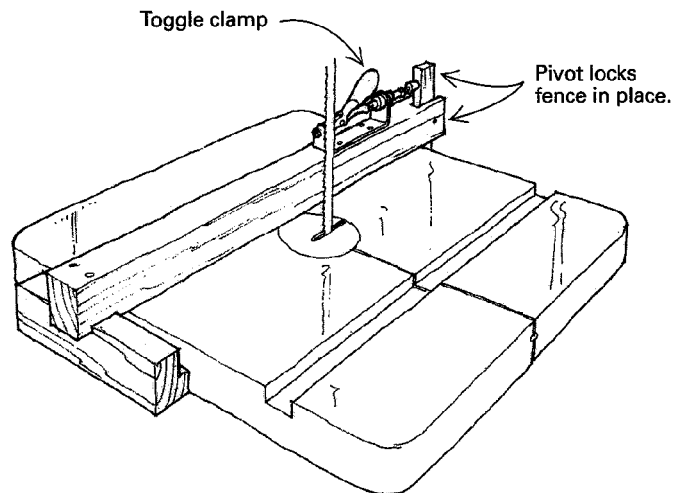

This bandsaw fence, made from scrap hardwood, locks in place with an ordinary horizontal toggle clamp. Size the components to fit your table and cutting requirements. It is easy to fine-tune the locking pressure with the threaded adjustment provided on the toggle clamp.

—Larry Griech, Ridgway, Pa.

Quick tip: An ordinary carriage bolt makes a surprisingly effective glue spreader. Squeeze a bead of glue on each joint face, and use

the bolt's threads to distribute the liquid evenly, like a notched trowel metering out adhesives for floor tiles. After a quick rinse, the threads are clean for the next use. —Hank Schoch, Fruita, Colo.

Cutting hinge mortises

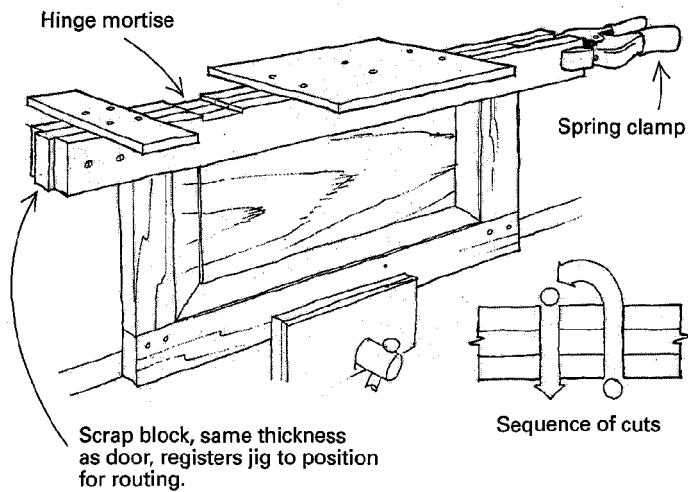

Periodically, I build Colonial-style kitchen cabinets with flush-mounted doors. One kitchen can have at least 20 or so doors with

relatively small butt hinges mortised into the edge of each door. To cut the hinge mortises, I use a router and a simple jig made from scrap. It consists of two arms spaced apart by a block the same thickness as the door frame. This spacer block also serves as a stop block in positioning the jig on the doors. I attach two 1/2-in. plywood fences to the top of the arms. The distance between the fences determines the size of the hinge mortises. Calculate this distance by adding the base of the router plus the width of the hinge minus the width of the mortising bit. Secure the jig to the door with a spring clamp.

To use the jig, put a door in the bench vise. Place the jig on the door with the stop block placed snugly against one end, and clamp it in place with the spring clamp. Set your router to a depth slightly less than the thickness of the hinge.

Reduce tearout by cutting the first and second passes, as shown in the drawing at left, and then clean out the remainder in the middle. Reverse the door in the vise, clamp the jig to the other end and cut the second mortise.

This jig is so easy to build that I don't bother to make it adjustable. I just keep one on hand for each size hinge I use.

—Jeff Lind, South Berwick, Maine

Methods of Work buys readers' tips, jigs and tricks. Send details, sketches (we'll redraw them) and photos to Methods of Work, Fine Woodworking, P.O. Box 5506, Newtown, CT 06470-5506. We'll return only those contributions that include an SASE.

Quick tapers on the tablesaw

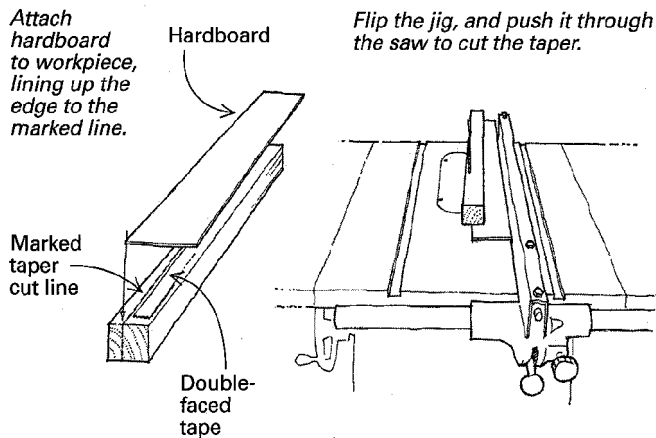

Here's a quick and foolproof way to cut tapers. First draw the desired cut line on the workpiece in pencil. Set the saw fence to a width slightly greater than the workpiece, and cut a scrap of hardboard to this width. Using either double-faced tape or tacks, affix the hardboard to the workpiece, carefully aligning the edge of the hardboard to the pencil line. Run this assembly through the saw without resetting the fence.

The saw will cut a precise taper, right to the line.

—Leigh Jerrard, Los Angeles, Calif.

Quick tip: If you store your waterstones in water, add a few drops of household bleach to it. The bleach will prevent algae from growing in the water and will not damage the stones.

—Robert Thayer, Brewster, Mass.

A beveling fixture for the planer

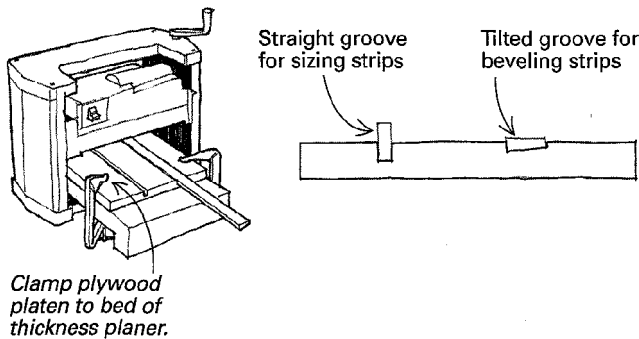

I wanted to use Tony Konovaloff's technique of using beveled hardwood strips for glazing cabinet doors (*FWW* #116, p. 49), but I didn't want to handplane all the strips. So I designed a technique to do the work using my thickness planer and a plywood platen. I'm sure that this method could be easily adapted to many other small-stock-milling needs, making them simpler and safer.

Start by milling the rough blanks and surfacing them to thickness. Then make a platen to fit the bed of your thickness planer by cutting grooves in a piece of plywood. In the drawing, there are two grooves—one to hold the stock on edge and a second groove

to bevel the strips. I cut this second groove by tilting the tablesaw blade 5°. The platen grooves support the blanks on two or three sides and guide them through the planer.

To use the fixture, clamp the platen to the planer bed, and pass the blanks through, taking light cuts.

—Bruce Gillies, Aurora, Ont., Canada

Drill-press sharpening tree

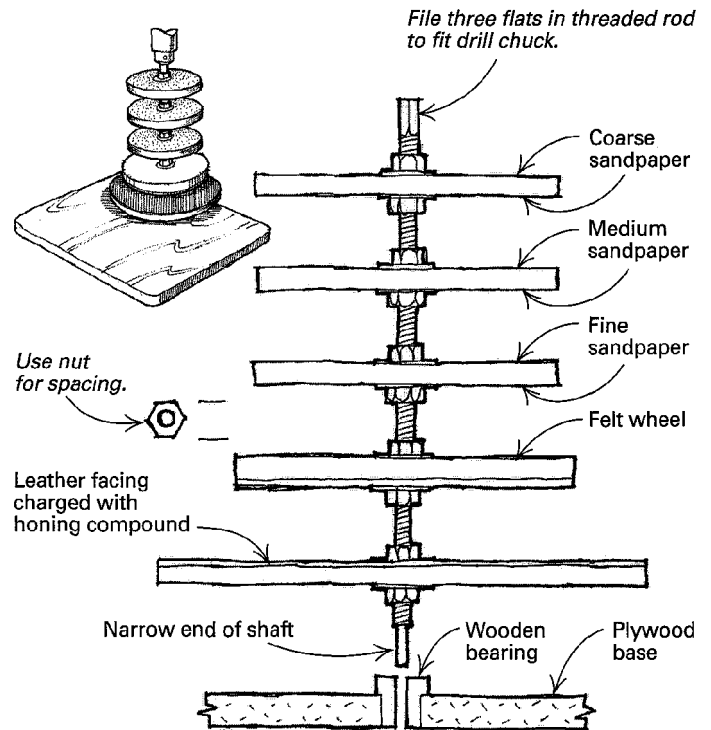

Sharp tools are fundamental to woodworking, but it should not take a lifetime of practice or involve a large cash outlay to sharpen them. This drill-press powered sharpening tree not only satisfies these requirements but also eliminates any worry about ruining the temper in tools by overheating them.

The device consists of a series of medium-density fiberboard (MDF) discs mounted on a central shaft. Each disc is covered with a progressively finer abrasive. The whole gadget is mounted on and driven by a drill press. To make it, cut three 5-in. discs and one 8-in. disc from 1/2-in. MDF. Buy a 6-in.-dia. hard felt disc, and cut a 1/2-in. plywood disc to support it. Glue coarse, medium and fine sandpaper to the three 5-in. discs, and attach a disc of thin tooling leather to the 8-in. disc for stropping.

Start with a 12-in. length of 1/2-in. threaded rod. Remove the threads from the bottom 1 in. of the rod with a belt sander or a grinder, and file three flats on the top to fit the jaws of the drill-press chuck. Cut out a plywood base to bolt to the drill-press table. Bore a hole in the base, and insert a hardwood dowel to serve as a bearing—it will last longer. Drill a hole in the dowel to accept the bottom of the threaded rod.

Now you are ready to assemble the tree. Slide the discs onto the

rod, and hold them in position with nuts and flat washers on both sides. Slide the bottom of the rod into the hardwood bearing, adding a little grease for lubrication. If you prefer, add a tool rest ladder (not shown) to complete the device.

To use, set your drill press at a low speed. Start sharpening at the top of the tree, and work down through the progressively finer abrasives. Finish up on the felt or strop, which has been charged with honing compound. —*Herbert Stait, Dundas, Ont, Canada*

Adding cushioned handles

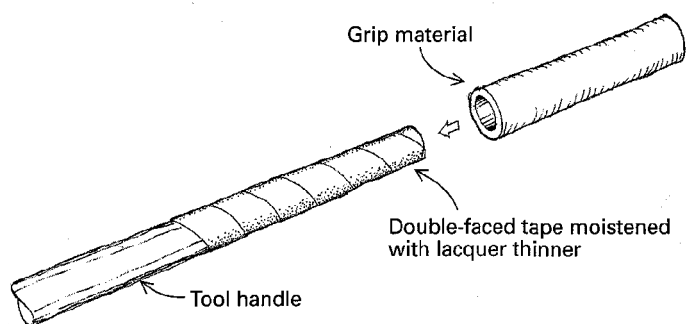

To attach a rubber or plastic handle over a wood or metal shaft, you can borrow a trick from golf club shops. Wrap the shaft with double-faced tape, and then moisten it with lacquer thinner to make it slippery. Slip the handle over the shaft. When the solvent dries, the handle will be locked in place.

—*Henry Fisher, Columbus, Ohio*

Inlaying strips in pre-finished wood

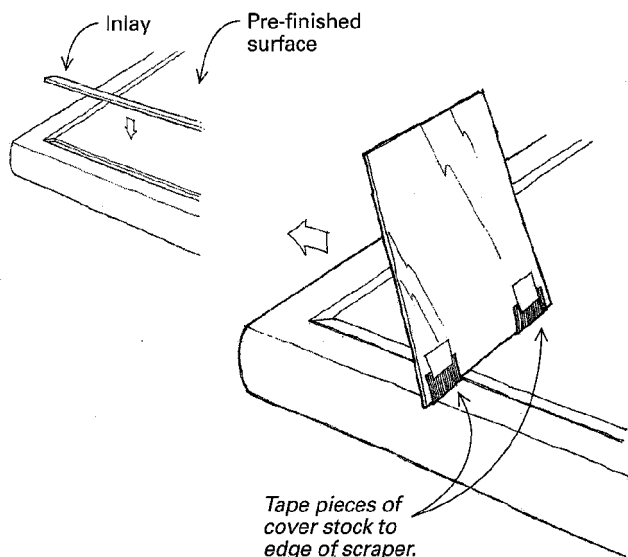

When inlaying a decorative strip or a medallion in a tabletop, I've found that it's helpful to stain and apply one coat of varnish on the top prior to cutting the grooves for the inlay. This preserves the contrast between the strip and the background, and it keeps glue smears from ruining the finish by blocking the stain. But in

leveling the strip, it's possible, inadvertently, to tip the scraper slightly and remove the layer of finish.

To avoid this problem, I tape two pieces of paper around the cutting edge of the scraper, leaving space between them for the inlay strip to be leveled. I can scrape the inlay nearly to the level of the substrate without ruining the finish. Good-quality coated paper, such as the cover of *National Geographic* magazine (.0045 in. thick), is ideal for this purpose.

—*John M. Van Buren, Herndon, Va.*

Quick tip: Some woods like poplar and cherry are difficult to carve, even when your tools are sharp. The wood seems to stick to the tool. Next time you are finishing up a carving in one of these woods, paint the surface with a good coat of mineral spirits. The solvent will soak in and lubricate the wood to make all those final smoothing cuts much easier to make. After evaporation, the mineral spirits won't affect the finish.

—*Michael Burton, Glorieta, N.M.*

Two resawing techniques

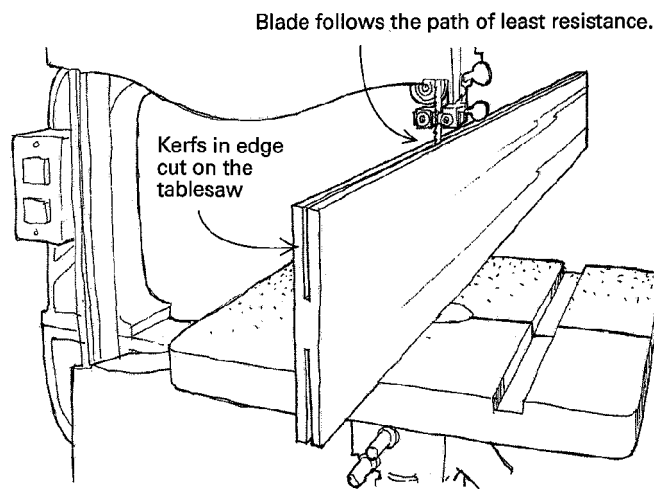

As a student at the School for American Craftsmen at the Rochester Institute of Technology, I learned a useful procedure to keep a bandsaw blade from wandering when resawing large planks. Start by kerfing both edges of a board on the tablesaw, centering the cuts on the resaw line. Be sure to register the same side of the board against the fence when making these cuts into the edges. The deeper the kerf the better. But if the wood pinches the blade, it's safer to make several passes.

Pass the board through the bandsaw, cutting the waste between the two kerfs. The interior edges of the kerfs act like blade guides to keep the blade from cutting into the surface of the two new boards. Finally, plane the waste from your two new planks.

—*William Crocca, Rochester, N.Y.*

To resaw, I make rip cuts in both edges of the timber, taking care to flip the timber end over end, so the cuts line up exactly. Although I have a 12-in. tablesaw that gives me a depth of cut of just over 4 in., I leave a narrow, unsawn strip separating the two cuts. Then I run

my reciprocating saw through this narrow strip. The blade takes the line of least resistance and never cuts into the surfaces sawn on the tablesaw.
—Roger Kirby, Emu Park, Queensland, Australia

Fastening a tabletop with brackets

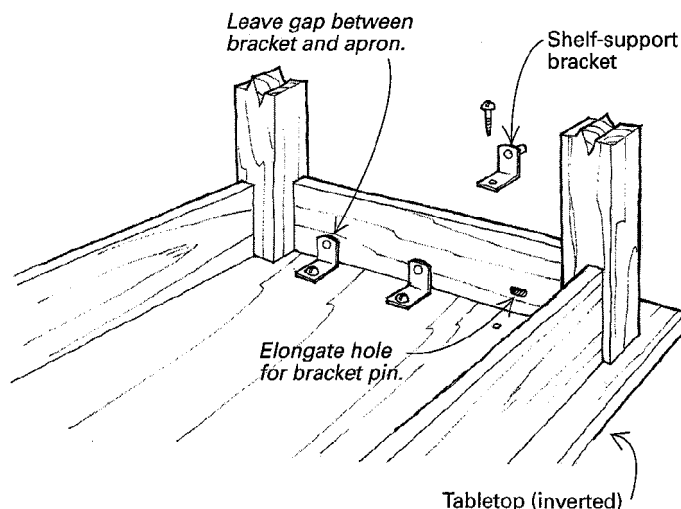

While building a small table with my daughter, I came up with a new way of attaching the top to the aprons using shelf brackets left over from previous projects. I drilled a hole in the tongue of each bracket for a screw. The bracket's pin fits in a hole drilled in the apron. To accommodate wood movement, I left a bit of space between the bracket and the apron, and I elongated the hole in the apron to allow the bracket to pivot. When the pin was inserted in the apron slot, I screwed the bracket to the underside of the table. The brackets are designed to support shelves loaded with books, so they should be sturdy enough to hold down a tabletop.

—Andrew J. Lenhart, Royal Oak, Mich.

Making bulls-eye knobs

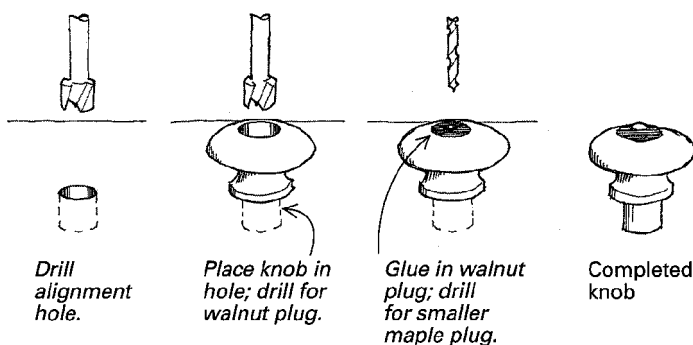

Here's how to make knobs with concentric rings of alternating woods. First turn or buy some maple knobs with round tenons on the back. Clamp a flat piece of stock to the drill-press table, and bore an alignment hole using a bit that matches the diameter of the tenon. Place the knob in the alignment hole. Now chuck a 1/2-in. Forstner bit in the drill press, and bore into the top of the knob

about 5/8 in. deep. Be careful not to weaken the knob by drilling too closely to the narrow waist. Glue a walnut plug in the hole, keeping the grain consistent with that of the knob. Trim and sand the plug so that it's a little proud of the knob and curved to match the contour.

With the knob back in the drill press, bore a 3/16-in. hole in the walnut plug, and glue in a maple plug. Trim and sand the maple plug to a rounded button about 1/16 in. proud of the walnut surface. Chuck the knob in the drill press, adjust the speed to about 800 rpm and use a piece of 000 steel wool to smooth the concentric plugs. The heat caused by the friction will darken the maple and give the entire top of the knob a beautiful patina.

—William Shepard, Cambridge, Ohio

Quick tip: Foam water-pipe insulation makes a great pipe clamp cover. It is inexpensive, comes pre-split and can be cut to length with scissors.
—Bill Kershaw, East Haven, Conn.

Router-height adjustment fixture

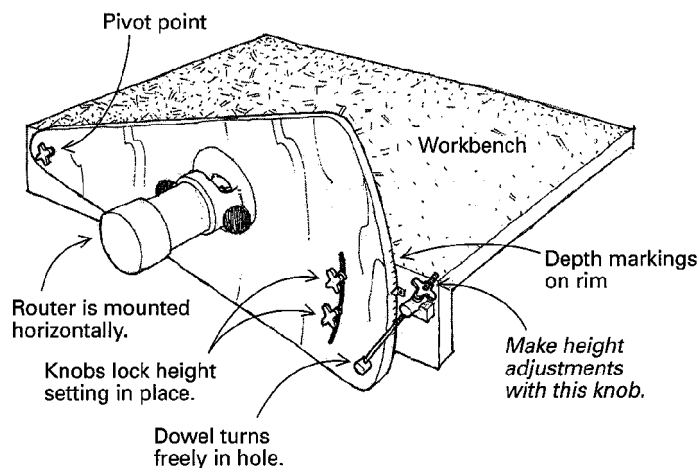

To make panels using vertical panel-raising bits on a traditional router table, you have to slide the panels on edge along a fence. This approach can be awkward, and the fence settings are hard to replicate accurately.

I found that I could get better results by mounting the router horizontally, as shown. This fixture allows you to make extremely fine height adjustments and accurate repeat settings. I made the wedge-shaped section that holds the router from 3/4-in. birch plywood. It pivots on the edge of a bench. To use, loosen the three locking knobs, adjust the router up or down with the adjustment knob and then clamp the router in place with the three locking knobs. The weight of the router keeps tension on the threaded adjustment rod.

Markings on the rim of the router piece allow adjustments (1/64 in. or less) and accurate repeat settings. Because travel at the rim is greater than travel at the bit, you must widen the spacing between the adjustment marks.
—Sid Ladenson, Tustin, Calif.

Methods of Work buys readers' tips, jigs and tricks. Send details, sketches (we'll redraw them) and photos to Methods of Work, Fine Woodworking, P.O. Box 5506, Newtown, CT 06470-5506. We will return only those contributions that include an SASE.

Smooth-running drawer guides

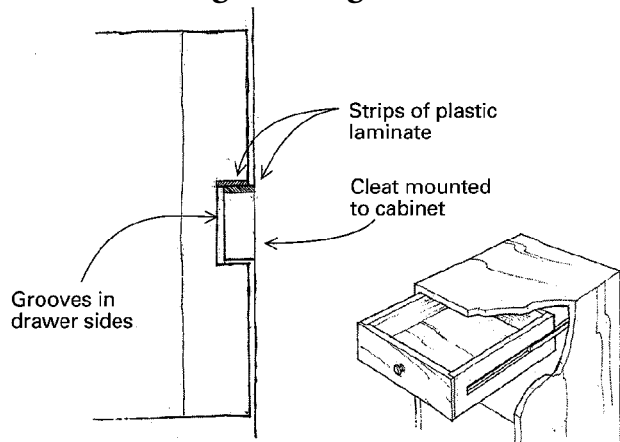

Here's an elegant way to make a smooth-running drawer without using those expensive metal drawer slides that take up too much space. The technique is a twist on the classic cleated-drawer approach—grooves on the sides of the drawer mated to corresponding cleats on the sides of the cabinet case. The twist is to glue a strip of plastic laminate on top of the cleat and on the underside of the top of the groove. The drawer slides smoothly on the surfaces of the laminate.
—Andrew Gibbs, West Palm Beach, Fla.

Quick tip: To patch the kerf line on a radial-arm saw table that has grown wide over time, mix sawdust and epoxy, and putty-knife it into the slot. After the epoxy sets, scrape and sand the area even with the table, and get back to work.

—M. Felix Marti, Ridgway, Colo.

Auxiliary switch for power tools

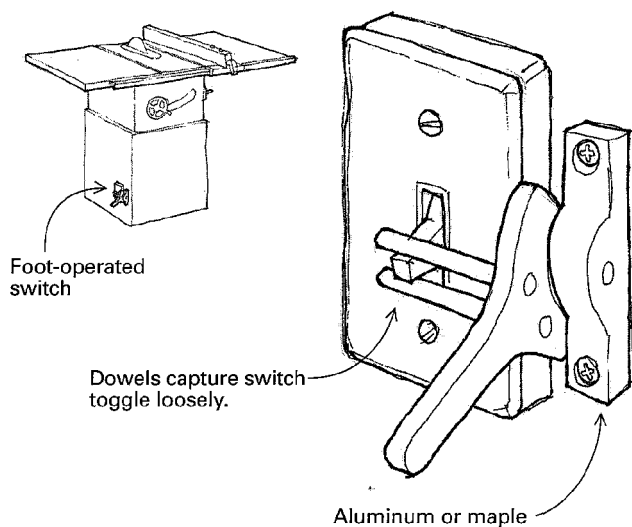

After experimenting with a dozen or so locations and types of tablesaw power switches, this is the one I find most convenient and safest to use. I mounted a standard 20-amp light switch low to the left side of the saw, as I face the blade. I added an auxiliary, foot-

operated lever to the basic switch, so my hands are free to handle the stock. The fingers of the auxiliary-switch lever only loosely trap the actual switch lever in both the on and off position, preventing any damage. I fabricated my latest edition of the switch lever from aluminum, but the original one I made from maple served me long and well.
—Dario Brisighella, Oak Creek, Wis.

Under-bench router-storage drawer

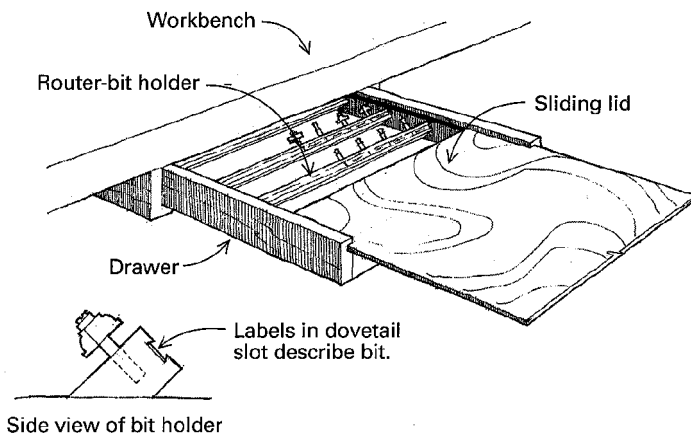

Space is at a premium in my garage shop. So I built this router-bit storage drawer that fits under my workbench. Make the case from 3/4-in. stock with routed slots to accept the bottom and the sliding lid. Cut the bit holder strips at a 45° angle on the bottom edge, and rout the top face of each strip with a 1/2-in. dovetail bit to hold labels describing each bit. The labels can include bit size and type (1/2 in. roundover, for example). The case is supported when partially withdrawn, or you can remove it completely for bit selection.

This storage system has been so effective that I added another drawer under the bench to store files.—Bob Bowles, Oxnard, Calif.

Adjustable router-table insert

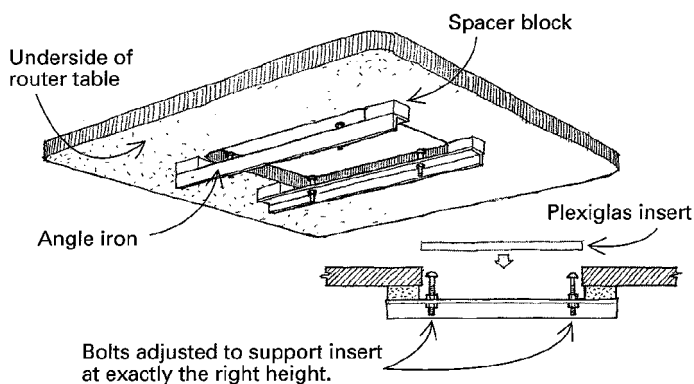

When I installed the insert in my router table, I didn't bother to rabbet the cutout hole to support the insert. Instead, I attached spacer blocks and two lengths of angle iron (mine came from an old bed frame) to the bottom of the router table. The edges of the angle irons protruded into the cutout about an inch. I drilled a pair of

holes in each iron and inserted a carriage bolt in each hole, as shown in the sketch on p. 28. The four round-head bolts stick up into the cutout space to support the plastic router insert at all four corners. The height of the insert can be adjusted perfectly to match the tabletop by adjusting the height of the four carriage bolts.

—Mike Holzhauser, Weare, N.H.

Clamping aid for odd angles

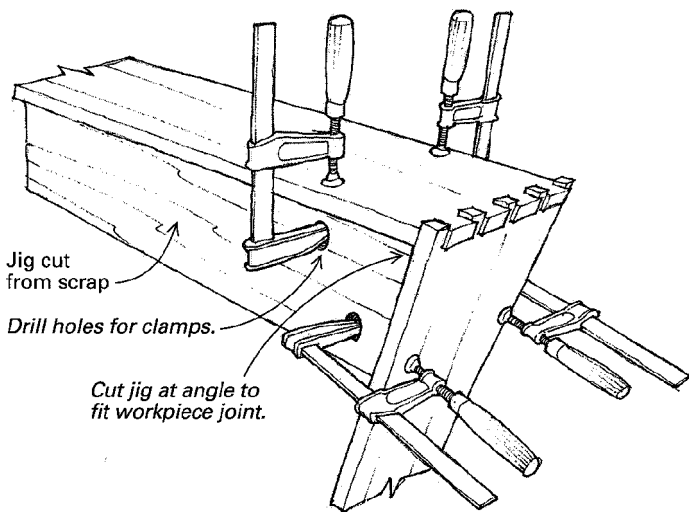

It is frustrating to clamp together two boards precisely at an odd-angled corner. This jig, which can be made quickly from scrap lumber, will help. Cut a generous scrap of hardwood to the appropriate corner angle, and drill holes through the scrap, as shown, to accommodate the head of a clamp.

Use two clamps for each jig piece, one on each of the two boards forming the corner. Make sure the inside corner of the joint is firm against the jig. One jig should suffice for joining narrow boards. Wider pieces will need two jigs, one on each edge, as shown.

—Keith R. Alien, Cedar Grove, N.C.

Using washers for drawing curves

Keep stack of different-sized washers for drawing arcs and rounding corners.

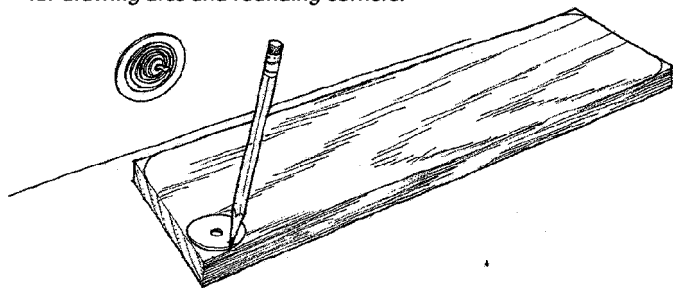

I keep a stock of washers in many sizes to use as templates when drawing rounded corners. Buy one washer of every size from the hardware store, and hang them on a nail in your shop. For larger

curves, use jar lids and paint can lids. They're all true circles and less trouble to use than a compass when only part of a circle is needed.

—Percy Blandford, Stratford-upon-Avon, England

Quick tip: I like to coat screws with beeswax to make them easier to install. To make a handy dispenser, melt the wax in a double boiler, and pour the melted wax into an old stick-deodorant dispenser. After the wax cools, slip a knife between the wax and the side of the dispenser to break the seal.

This handy dispenser keeps the wax clean. It also keeps the wax off your hands as well as your project. Just be sure that it doesn't end up in your medicine cabinet.

—Vincent J. Rucinski Jr., Wilmington, Del.

Tape measure glue-insertion tool

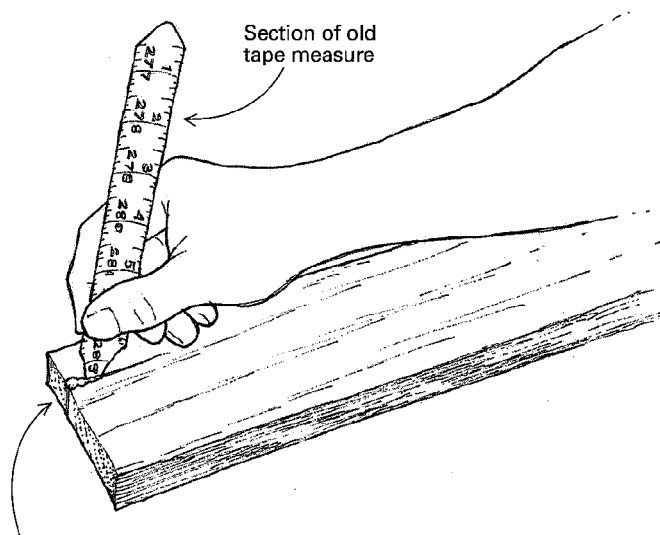

Cut profile on end to work glue into crack.

I'm sure most woodworkers have been faced with the problem of trying to force glue into a tight split or crack in the workpiece. My solution for this problem is to cut a 6-in. or so section from an old tape measure. Then I cut a profile on the end of the tape, varying the shape for different applications. The tape section is thin but stiff, and it's ideal for working glue into a crevice.

—Gregory H. Joy, Lincoln, Neb.

An alternative to winding sticks

The traditional method to determine if a workpiece is twisted is to use two winding sticks, as illustrated on the cover of *FWW* #120. I've found two difficulties with that approach. First, it's not easy to find perfectly straight sticks that won't warp. Second, it is not easy for those of us who wear bifocals, or thick glasses, to focus on both sticks at the same time.

My wife had another idea—use a carpenter's bubble level. Set the workpiece flat on the bench. Place the level on one end of the workpiece, and with a small wedge, level that end of the workpiece. Now, move the level to the far end of the workpiece. Any twist or winding will show up as an out-of-level condition. Using

my level, I'm convinced that I get better results than I would by using winding sticks.
—Winfield Sample, Eureka, Calif.

Custom-made fasteners

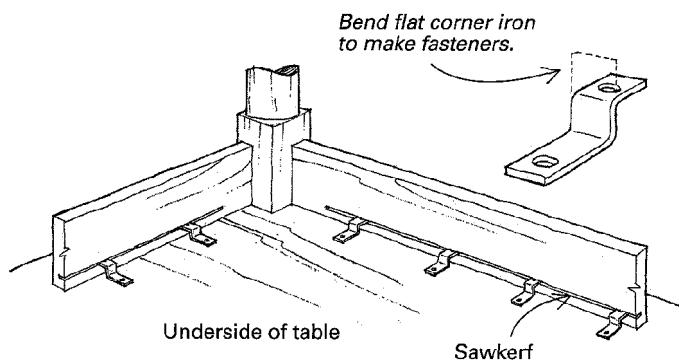

I make tabletop fasteners from steel corner irons. First I bend one leg of the iron at a right angle, as shown in the sketch. Then I cut a thin kerf in the table apron that this new bend will fit into. I just stick the end of the iron in the kerf and screw the other leg to the underside of the top.

This technique is quick and easy, and it allows plenty of wood movement.
—William D. Murrey, Madison, Tenn.

Making wood-dust filler

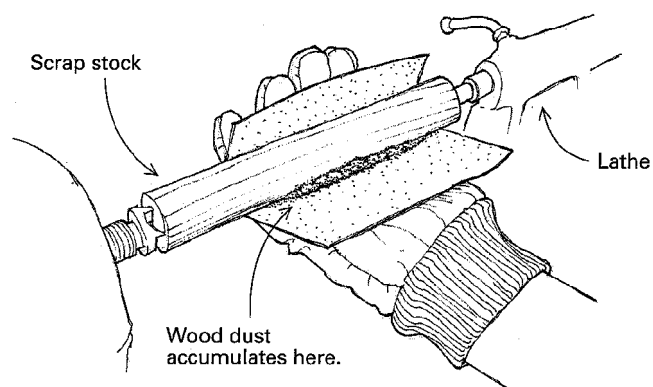

An easy way to generate dust to make wood filler is to turn a piece of wood on a lathe. With a gloved hand, hold a piece of sandpaper against the rotating piece. Sanding dust will quickly pile up on the sandpaper.
—Bill Kadi, Hayward, Calif.

Methods of Work buys readers' tips, jigs and tricks. Send details, sketches (we'll redraw them) and photos to *Methods of Work*, Fine Woodworking, P.O. Box 5506, Newtown, CT 06470-5506. We'll return only those contributions that include an SASE.

Easily aligned jig for routing shelf dados

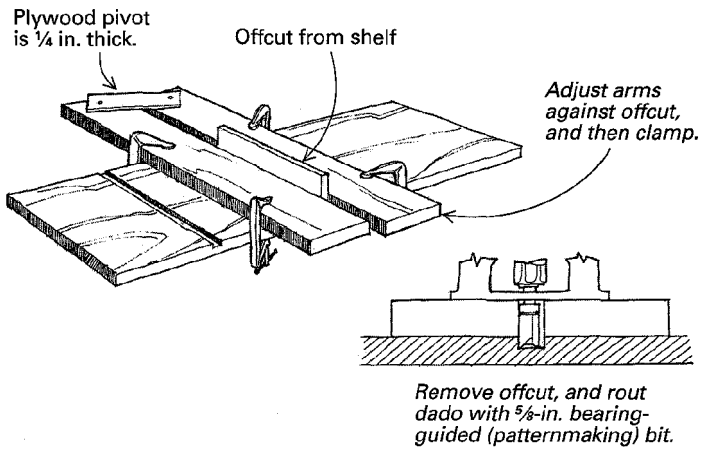

Recently, I had to rout lots of dados in cabinet sides for 3/4-in. plywood shelving. I came up with a method built around a 5/8-in. patternmaking router bit (with the bearing located above the bit) and a simple jig made from two pieces of 1-in.-thick plywood about 6 in. wide. The two pieces of plywood are joined by a small piece of 1/4-in. plywood at one end that pivots.

To use the fixture, clamp one side to the cabinet side along the index line you have drawn for the shelf location. Position an offcut of the same material you will be using for the shelf between the two parts of the jig. Swing the second fence toward the first fence so that it sandwiches the offcut, and clamp it in place. Now remove the offcut, and rout the dado, running the bit's bearing against the sides of the jig's arms.

This system is more accurate than any other method I've used. It even adjusts for minor variations in sheet thickness.

—Robert R. Knights, Woombye, Australia

Safer split turnings

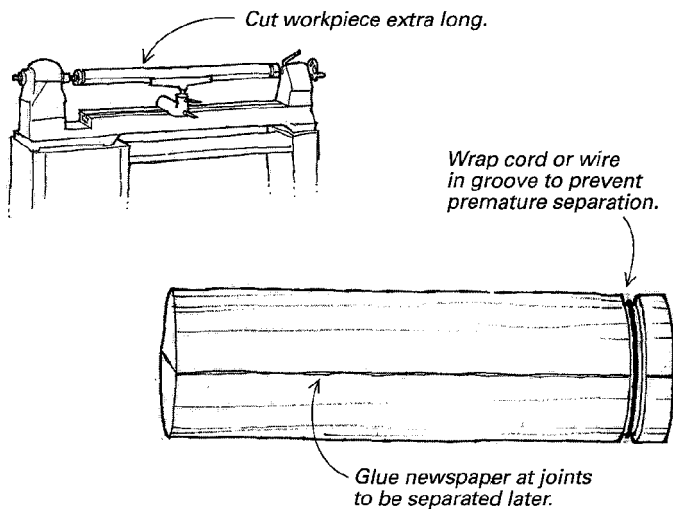

When a half- or quarter-section of a turned spindle is needed for a project, the usual method is to glue up sections of stock with a

sheet of newspaper between them. The newspaper layer allows the sections to be easily separated later. This approach works fine, but it is mighty disheartening—and sometimes scary—to have the turning come apart at the newspaper joint before it's finished. To avoid this, I make my blank extra long and turn a deep groove with my parting tool at each end of the stock. Then I wrap stout cord or wire around the groove and tie it off to prevent the pieces from flying apart. Once the turning is done, I cut the grooved ends off and separate the sections at the newspaper layer with a sharp chisel.

—Ken Picou, Austin, Texas

Quick tip: Kerosene is a great lubricant for sharpening stones. It is inexpensive, commonly available and has a slightly oily quality that lubricates well. I use it on my water, oil, ceramic and diamond stones. In addition, kerosene is a great brush-cleaning solvent, safer than gasoline and cheaper than mineral spirits.

—Robert E. Steel, Allegan, Mich.

Tablesaw extension fence

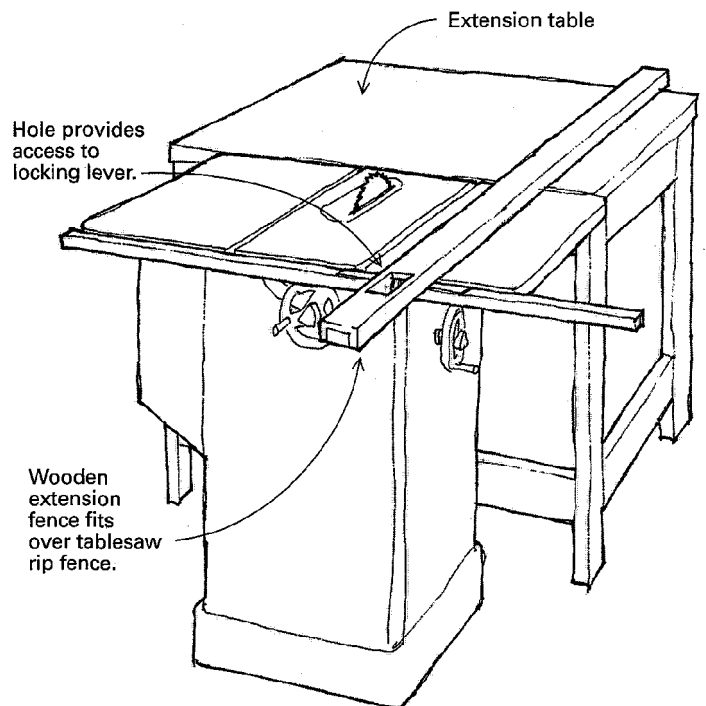

This wooden extension fence slips over the tablesaw's regular fence and more than doubles its length. It is an indispensable accessory when extended contact with the rip fence is necessary. Mine is sized to fit my tablesaw's Biesemeyer fence, but the concept could be adapted to other rip-fence designs.

To make the fence, build a U-shaped channel that fits neatly over the rip fence. Add pieces to close off both ends. Add baffles on the inside for strength and to lock the extension in place over the rip fence. Assemble the extension with glue and plenty of screws. I cut an access opening directly above the locking lever of the rip fence so that I can operate it from above or below. Two coats of varnish will protect the fence for years. To use the extension, just slip it

over the regular fence when you need it. Add an outfeed table at the back to support the extension fence and the workpiece.

—Dick Dorn, Oelwein, Ia.

Quick clamps for the drill press

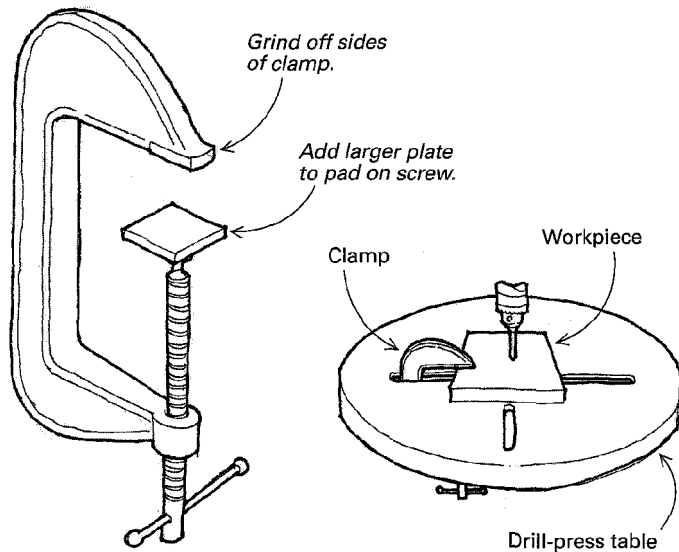

If your drill-press table has slots that go all the way through, you can make a quick clamp for securing smaller work to the table by grinding down the sides of a C-clamp. You will also need to enlarge the pad on the screw of the clamp. To use, simply slip the clamp through a slot, and tighten the workpiece. This approach is more convenient than trying to clamp the workpiece from the outside edge of the table.

—Dennis R. Brock, Rawson, Ohio

Plywood scoring fixtures

Fixtures raise work so blade scores plywood veneer on first pass.

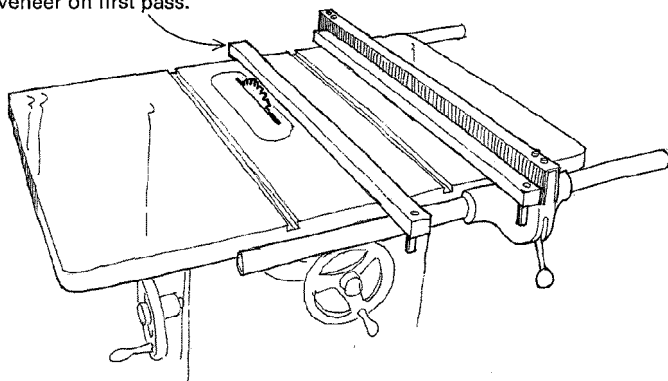

You can greatly reduce the fuzzing and tearout that goes with ripping plywood across the veneer grain by first scoring the lower side of the plywood with a shallow cut of less than 1/8 in. But this requires lowering the blade to make the scoring cut then raising it again to make the finish cut. These fixtures allow you to make a

scoring cut without all this fuss. Just put the two fixtures in place, one against the fence and one near the blade, and push the panel through to make the scoring cut. Then remove the fixtures to make the finish cut. Dowels on the ends of the fixtures prevent them from sliding forward during a cut.

—M. Dugan, Bohemia, N.Y.

Quick tip: It's hard to see pencil lines on darker woods like walnut or bubinga. I found a perfect solution in my drawer of computer supplies: Avery brand laser printing labels. I cut a portion of the sticky-backed paper from an 8½-in. by 11-in. sheet and stick it to the workpiece. A pencil line shows up well on the paper. And the paper can be easily removed after cutting or machining the workpiece, without leaving residue.

—James L. Hall Jr., San Francisco, Calif.

Jig for drilling cabinet shelf holes

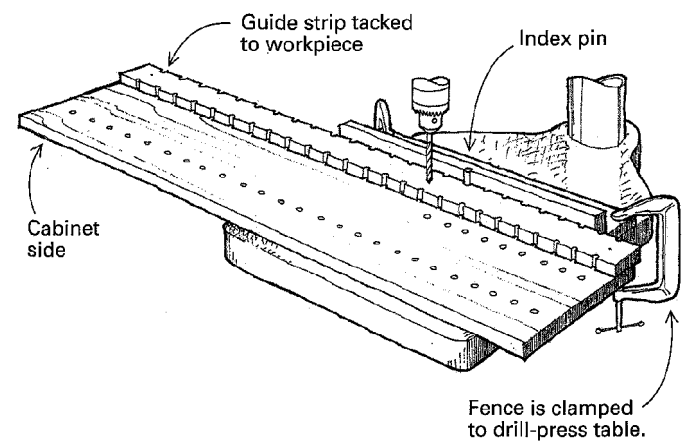

Here's a method for drilling the holes in cabinet sides for adjustable shelves. The jig consists of two parts: a guide strip temporarily tacked to the workpiece and an index pin in a fence clamped to the drill-press table. To make the guide strip, start with a length of 3/4-in. plywood about 3½ in. wide. Drill two parallel rows of 1/4-in. holes about 1¼ in. apart and spaced at the desired shelf-adjustment intervals. Take care at this stage to align and space these pilot holes accurately because they will determine the accuracy of the final shelf holes in the cabinet. Rip the guide strip through the holes so that half the holes remain on each side. The two outer ribs are scrap.

To make the index-pin fence, attach a length of 2-in.-wide plywood to a base that can be clamped to the drill-press table. Now drill a half-hole in the face of the fence by temporarily clamping a scrap piece to the front of the fence and drilling a hole that's half in the scrap and half in the fence. Remove the scrap, and glue a short piece of 1/4-in. dowel in the half-hole to produce an index pin.

To use, clamp the fence at the appropriate distance from the bit, and set the bit depth stop. Tack the guide strip to the workpiece with the top of the strip flush with the end of a cabinet side. The guide strip should overhang the side of the cabinet slightly more than one-half the diameter of the hole. This setup will allow the half-holes in the guide strip to mate with the index pin and position the workpiece correctly for each hole. One hand operates the

drill press and the other alternately holds and then advances the workpiece. When you establish a rhythm, you can drill a hole about every two seconds.

—Robert A. Loos, Medford, N.J.

Quick tip: Methyl ethyl ketone (MEK) will soften aliphatic-resin glues (like Titebond). Use a long-point squeeze bottle, and wet the joint from all edges for five to 45 minutes. If necessary, work a chisel in from an edge, and wet the resultant void, repeating that process frequently. With patience, the glue will soften, and you will be able to disassemble the parts at the glue joint.

—Chip Minck, La Mesa, Calif.

Making curved cauls on the tablesaw

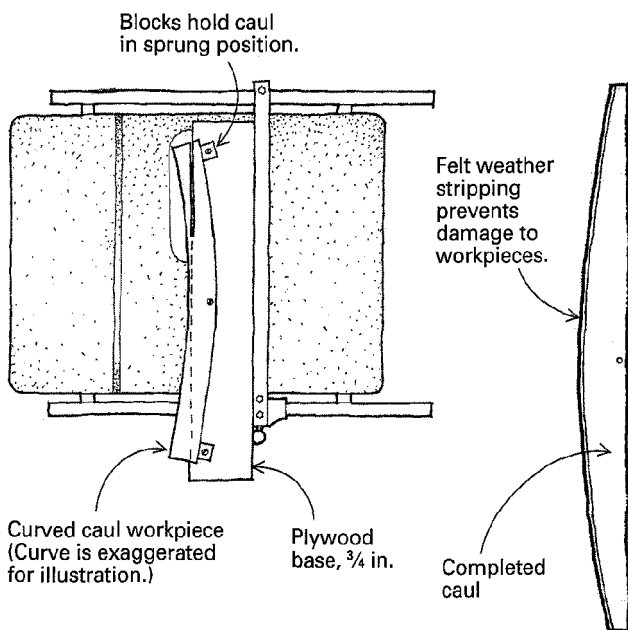

Recently, when I needed a dozen or so curved cauls for gluing solid wood banding to plywood shelves, I came up with this jig. The base is simply a strip of 3/4-in. plywood a few inches longer than the longest caul you want to cut. Rip the strip to 6 in. or so. Select the caul material. I used 1-in. by 1 1/2-in. oak. Ash or hickory would also work well.

Mount the caul material to the jig with one screw at its center point, placing it on the jig so that one edge is flush with the plywood edge. Move one end of the caul so that it overhangs the edge of the jig about 1/8 in. per foot of the length of the caul, and screw a scrap block in position behind it. Spring the opposite end to an equal amount of overhang, and screw another block in place. Now run the jig with the caul attached through the tablesaw to rip off the overhang. The fence is set to the width of the jig.

When the caul is removed from the jig, it will spring back to a gentle natural curve that provides uniform pressure when clamped down. Cauls of any length can be made by repositioning the stop blocks. This method is so quick and easy that I now have cauls in many sizes. To provide a cushioned pressure surface, I glue on weather-stripping felt to the face of the caul.

—Rick Hodges, Deer Park, Wash.

Masking tape dispenser

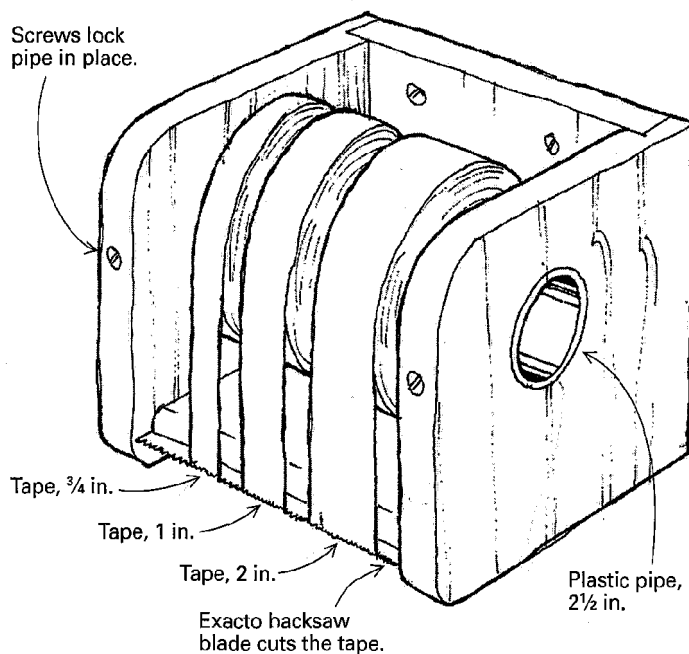

I use a lot of masking tape in my work, often in different widths. Not being the neatest woodworker, I used to spend a lot of time looking for a misplaced roll of tape just to tear off one little piece. So I built this wall-hanging tape dispenser to hold the widths of tape that I use. The axle is a length of 2 1/2-in.-dia. plastic pipe held in place with screws. I experimented with other tape cutters—an old jointer knife and a hacksaw blade—before discovering that an Exacto backsaw blade works best. I fixed the backsaw blade into the rounded edge of a piece of wood and set that about 1/2 in. from the front of the dispenser. This way, the blade does not stick out in front. To use, I just pull down on the tape and tear at the blade.

—Bob Gleason, Hilo, Hawaii

Quick tip: Cover bar or pipe clamps with split-plastic shower-rod covers to prevent those black stains you get when iron contacts wet glue on the wood.

—Davis G. Durham Jr., Landenberg, Pa.

Simple star construction

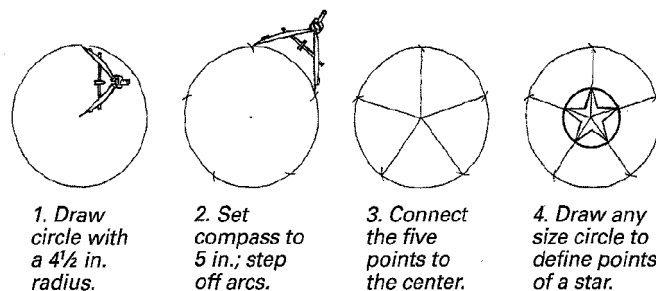

Here's a simple way to construct a five-pointed star. It's easy to remember, and it doesn't require a protractor or a math degree. Draw a circle with a radius of 4 1/2 in. Set the compass to 5 in., and

step off arcs around the circumference. That's it. The arcs will divide the circle into a perfect pentagon. Draw lines from the center point through these arcs. Where any circle cuts these lines, you have the five points for a star or pentagon.

—Bruce Revell, Magill, South Australia

Framing-square calipers

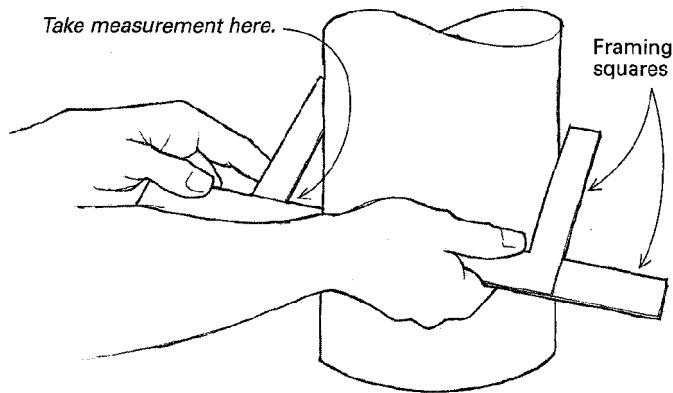

This may be an old trick, but I thought of it myself and was smiling the rest of the workday. My spring calipers measure only up to 6 in. One day, I needed an exact measurement of a wooden column that

was several inches larger than that. It occurred to me that I had two small framing squares the same size. I mated the bodies together, as shown in the sketch, and took the measurement where the tongue of one square intersected the interior scale of the other one.

—Mark Dichiaro, Atlanta, Ga.

The last lap: honing steel with aluminum

After 60 years of sharpening chisels and plane irons, I thought I'd achieved the ultimate edge when I finished off the job with an 8,000-grit Japanese waterstone and a leather strop. That was before I discovered that I could achieve an even finer edge by lapping the blade on aluminum.

Start with a section of extruded structural aluminum about the size of a benchstone. Apply a little mineral spirits to the flat, and stroke the tool on the aluminum just as you would on a regular whetstone. The aluminum will lap a tiny amount of steel from the cutting edge.

The resulting edge is incredibly sharp—so much so that I almost feel as if I'm working without a blade in the plane.

—James R. Thomson, West Vancouver, B.C., Canada

Methods of Work buys readers' tips, jigs and tricks. Send details, sketches (we'll redraw them) and photos to *Methods of Work*, Fine Woodworking, P.O. Box 5506, Newtown, CT 06470-5506. We will return only those contributions that include an SASE.

Inexpensive bench vise

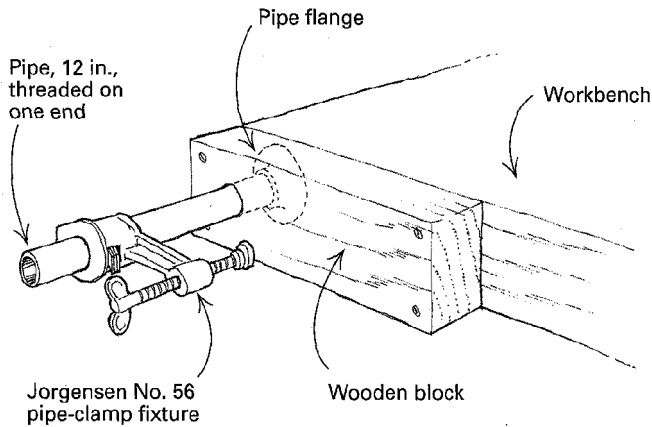

This inexpensive substitute for a left-handed workbench vise allows you to clamp a panel all the way to the floor, if necessary. It has no guide rods or screws to interfere with a vertical workpiece, as with a metal vise. It probably doesn't match the quality of a left-handed vise from a top-end woodworking bench, but it is surprisingly useful and easy to build.

To make the vise, first secure a pipe flange to the bench edge. Use long screws because the vise exerts a lot of pressure. Fit a 2-in.-thick block over the flange, as shown. Screw the block to the workbench. A 12-in. pipe threaded on one end and the movable end from a Jorgensen No. 56 clamp fixture complete the assembly. If desired, you can attach a wooden block to the end of the clamp screw pad to gain more surface area and even out pressure. Take care not to walk into the pipe. —Anthony Guidice, St. Louis, Mo.

Fold-away tool racks

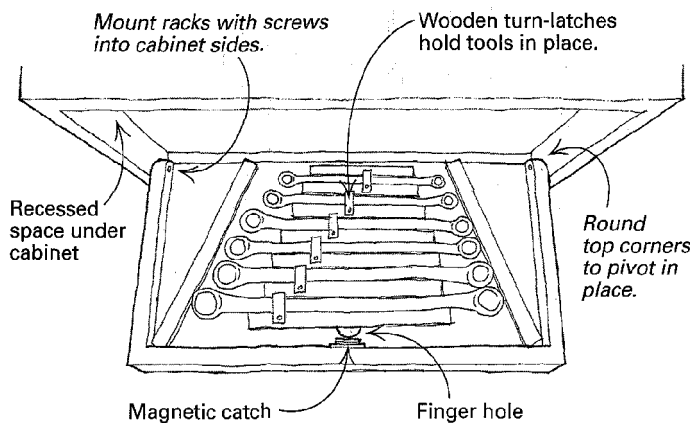

Upper kitchen cabinets are usually constructed with a 2-in. or so recess in the bottom. When I built cabinets for my workshop, I used this space to install pull-down tool racks. The racks are ideal for holding relatively thin and commonly used tools, such as chisels, wrenches and screwdrivers.

Pin the back corners of the rack to the cabinet sides with wood

screws, and shape a radius on the top corners to allow clearance for the racks to pivot. Bore a finger hole to open the racks, and install a magnetic catch to keep them closed when not in use. Hold the tools in place with suitably spaced strips of wood and wooden turn-latches.

I'm in the habit of closing the racks when all the tools in the set have been returned. So an extra bonus is seeing at a glance if any tool has been misplaced. —Adrian Jones, Youngsville, N.C.

Avoiding end-grain tearout

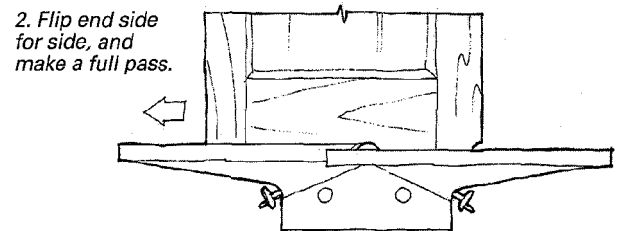
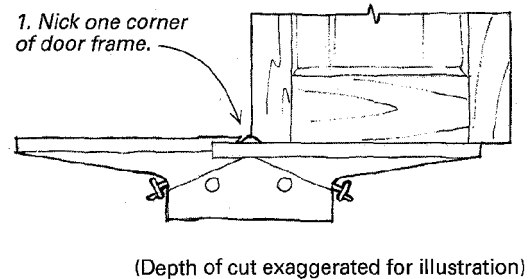

In our sash and door shop, we use a jointer to clean up top and bottom edges of frame-and-panel doors. To avoid end-grain tearout, nick approximately 1/4 in. of one corner of the end-grain edge at the jointer setting to be used. Then flip the piece, side for side, and make a full pass along the edge. After the end-grain sections are jointed, you can joint the long edges with the grain. This sequence will produce crisp corners.

—Chip Minck, La Mesa, Calif.

Symmetrical drawings

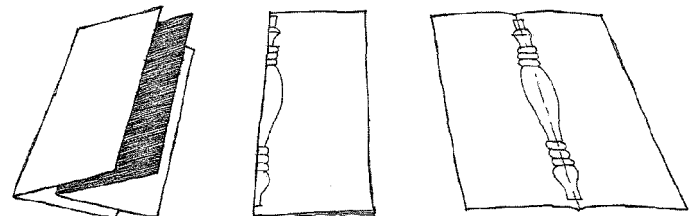

Insert carbon paper, ink side out, at fold of drawing paper.

Draw half-image of design pattern.

Open to see full symmetrical pattern.

Here's a simple method for drawing an intricate turning to see what the finished product will look like. It also works great for drawing symmetrical patterns often used in wood carving or scroll

sawing. Fold a piece of paper in half. Insert a folded piece of carbon paper, inked side out. Sketch half of the design on the outside of the folded piece of paper with the fold at the centerline. When you are satisfied with your half-design, remove the carbon paper, and open the folded paper. Your full drawing will appear on the inside.

—John Saggio, Little Neck, N.Y.

Quick tip: The quickest and easiest way to cut foam upholstery material is with an electric carving knife.

—James B. Lemyre, Saugerties, N.Y.

Making a steambox

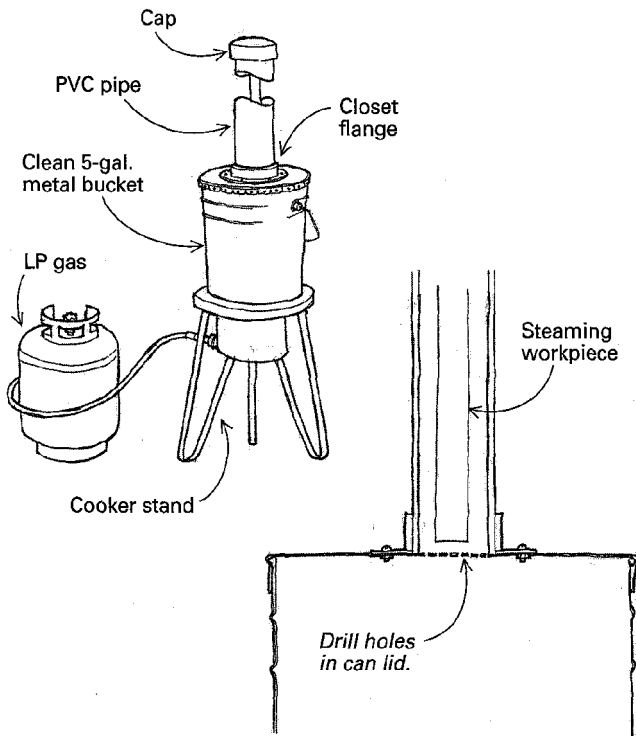

This steambox is made with a liquid propane gas cooker, a common 5-gal. metal paint can (scrubbed clean), a closet flange (the plumbing fixture for mounting a toilet onto the floor) and a length of 4-in. PVC pipe. Bolt the metal closet flange to the lid of the can, and drill numerous holes through the lid within the circumference of the collar. Set the PVC pipe on the collar to make a chamber for the wood being steamed. Because I steam mostly chair posts and strips for Shaker boxes, I cut the PVC pipe 48 in. long. But you can vary the length of the tube to suit the workpiece. While the steambox is working, I set a PVC end cap loosely over the tube.

The vertical configuration is quite efficient because it allows the condensed steam to return to the boiler. Chair posts are steamed and ready to bend in about two hours.

—Thomas A. Heffernan, Shaker Heights, Ohio

Threading wire through a hollow casting

Getting stiff work-light cord through the hollow top casting of older bandsaws is easy. First cover all openings with tape except for

the cord input and exit holes. Next put a vacuum cleaner nozzle to one hole and then feed in some string through the other. Eventually, the vacuum will pull the string through. The cord can then be pulled through with the string. The same trick works well for getting any stiff wire through a hollow cavity.

—Robert Vaughan, Roanoke, Va.

Threaded handle replaces thumbscrew

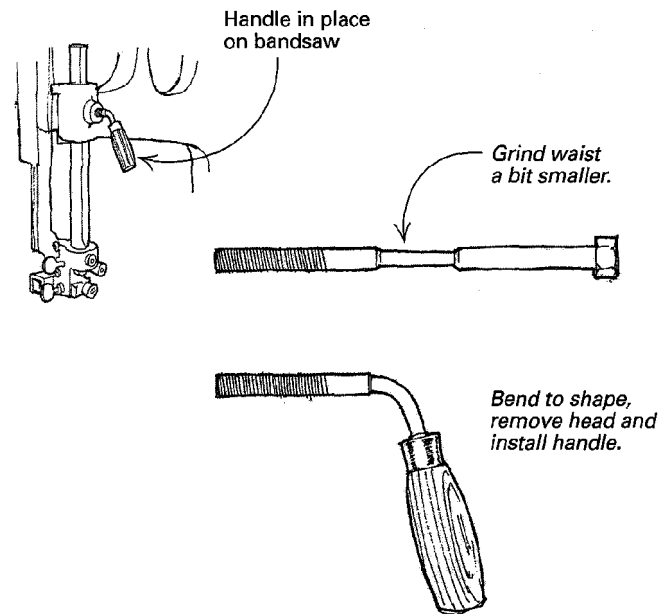

In Ronald Volbrecht's resawing article (*FWW* #122, pp. 74-79), I noticed that he had added *Vise-Grip* pliers to a thumbscrew to gain additional leverage. A more permanent alternative is to make a handle from a regular $\frac{3}{8}$ -in.- by 4-in.-long bolt. Grind the waist of the bolt behind the threads a little thinner, and bend the shank into a dogleg angle of 80° or so. The bending will go easier if you first heat the shank with a torch. Cut the head off the bolt, add a nice wooden handle and replace the thumbscrew with the threaded handle. Your *Vise-Grips* will now be available for other uses.

—Lloyd Litt, Sauble Beach, Ont., Canada

Freeze-drying veneer

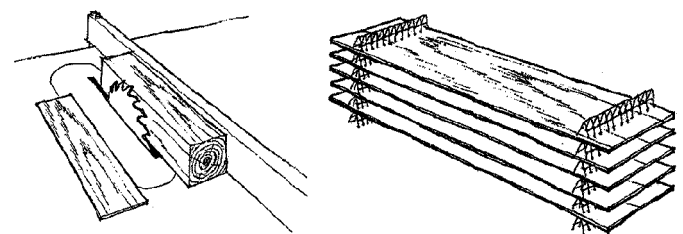

Slice $\frac{3}{32}$ -in. pieces of veneer from squared-up tree branch.

Stack veneer in freezer, separated by hardware cloth stickers.

Here is a great way to make perfectly flat $\frac{1}{16}$ -in.-thick veneer from fruit tree prunings and other freshly cut local woods. I use this

method to make madrone veneer for the natural keys on harpsichords. Use only the freshest material. The best branches are 3 in. to 4 in. round by 1 ft. long. Square three sides on the jointer, sizing the parallel sides just short of the maximum cut on your tablesaw. You can go thicker if you have a bandsaw. Now cut as many $\frac{3}{32}$ -in. slices as safety will allow. Brush away the sawdust, and rush the fresh veneer to the nearest frost-free freezer.

Keep the slices separated (I use stickers made from strips of $\frac{1}{2}$ -in. hardware cloth to do this), and stack the wood in the freezer. The slices will quickly freeze in the same position as they were cut. Leave the veneer slices in the freezer until they dry, which will take some time—six weeks to three months, depending on the species. To test for dryness, place one slice on the kitchen cabinet overnight. If it twists it's not dry. After you remove the dried veneer from the freezer, stack the pieces between layers of paper towels, and press flat until needed. Slices thicker than $\frac{3}{32}$ in. won't work.

—Roger Russell, Anderson Island, Wash.

Quick tip: When spraying small items, I catch the overspray in my wheelbarrow. It keeps the wheelbarrow from rusting and is more environmentally friendly than some of the alternatives.

—Arlo Ames, Albuquerque, N.M.

Thickness sanding on the drill press

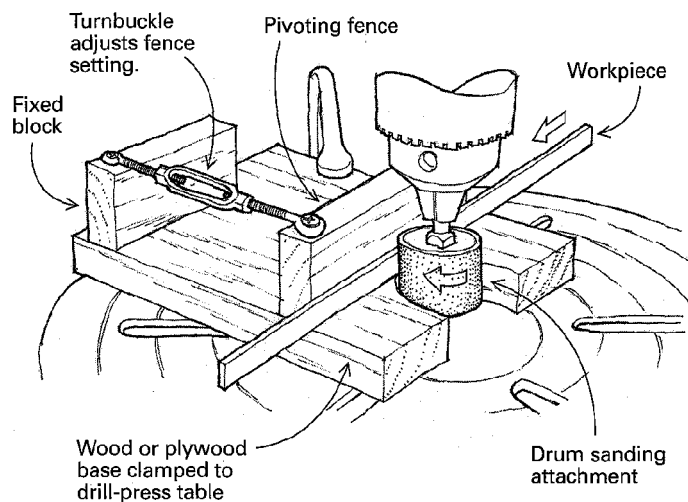

One day when my large thickness sander was down for repairs, I needed to make a length of very thin banding for an antique I was restoring. Within an hour, I had made the drill-press thickness-sanding fixture shown above from scraps around the shop. It works exceptionally well. With it, I can turn out a length of $\frac{1}{32}$ -in.-thick banding in a minute.

The fixture consists of a plywood base, cut on one edge to receive the sanding drum, and a pivoting fence that adjusts via a small turnbuckle. The other end of the turnbuckle is attached to a fixed block glued to the base. I brushed some shellac on the threads to prevent the turnbuckle from vibrating and turning during use.

To use the fixture, I cut a rough strip on the tablesaw and feed it against the rotation of the sanding drum with one hand while pulling with the other. The trick is to keep the strip flat against the

fence and feed it steadily. I give the turnbuckle a half-turn on each pass until I sand the strip to the proper thickness. The device is safe to use and will sand down a strip of wood to a thickness almost like that of paper. I now use the fixture for making guitar binding and purfling. —E. Richard Goodall, Salmon Arm, B.C., Canada

Glue spreader for biscuit slots

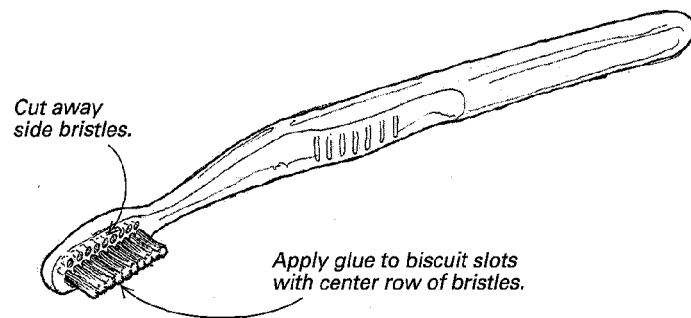

To spread glue in biscuit slots, cut off the outside rows of bristles from an old toothbrush, leaving the center bristles intact. This brush works almost as well as those special-purpose biscuit-slot glue bottles. —Quentin E. Smith, Eugene, Ore.

Wall-mounted hanging system

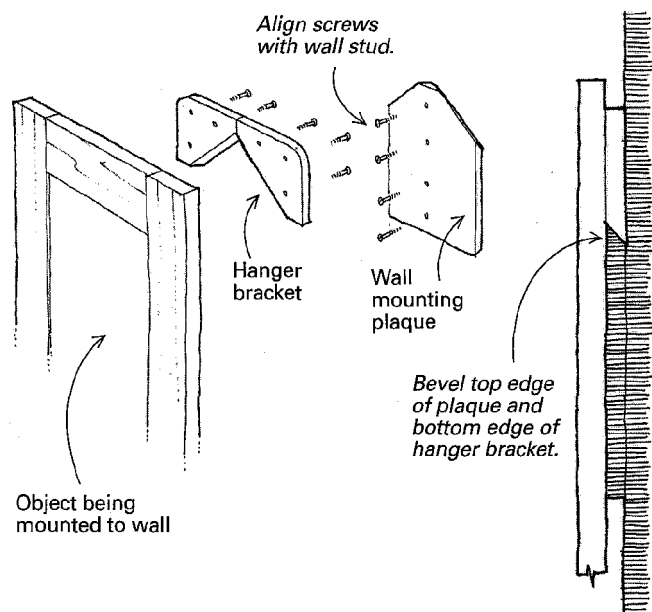

I use this system to mount small cabinets, mirrors and shelves to a wall. With this approach, you can lock the piece securely to the wall and lift it on and off easily. There are two parts, both made of $\frac{3}{8}$ -in. plywood: a mounting plaque that is screwed to the wall and a hanger bracket that is screwed to the back of the cabinet. Both parts are beveled on the edges where they meet, as shown in the sketch. This system is especially well-suited for mounting into stud walls because all the screws fall in a line along a single stud. Provided the hanger bracket is carefully squared when it is attached to

the cabinet back, plumbing the cabinet is just a matter of placing a level against the wall plaque when you attach it to the wall.

—Tom Svec, Lock Haven, Pa.

Wedge quick-clamp

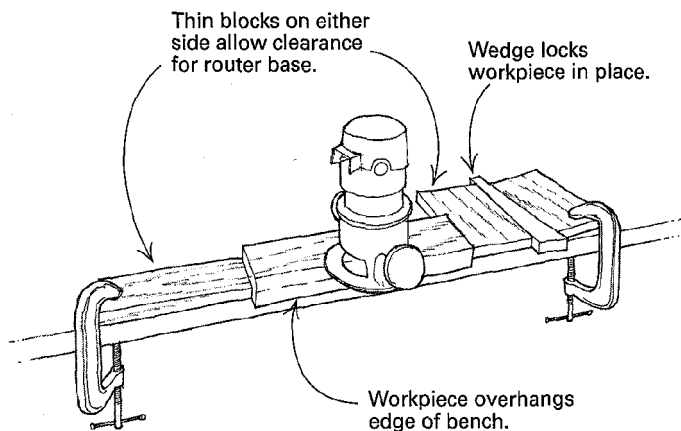

On many of my projects, I round over the front edges of large numbers of identical pieces of wood, such as shelves. Often the router-bit bearing extends below the bottom edge of the workpiece.

With a simple wedge-clamp system, I can quickly secure a work-

piece. The setup allows clearance for the router-bit bearing, and the thinner end blocks on each side of the workpiece allow clearance for the router base. I tap a wedge into place between the end block and an angled wedge block to hold the workpiece in place.

—Jean V. Rensel, Sanborn, N.Y.

Sanding tip for turnings

This may sound backward, but if you apply paste wax to a turning *before* sanding, you'll sand faster and cooler, reduce dust and increase the life of the sandpaper. Apply a generous layer of paste wax to a completed turning, and then start sanding immediately with a piece of 80-grit paper. Yes, the paper will fill with wax and dust, but it will continue to remove wood efficiently. Even those areas of the paper that look hopelessly loaded will continue to cut.

With this method, you get very little airborne dust and the workpiece stays considerably cooler. After sanding with 80-grit, I step through 120-, 220- and on to 400-grit. By the end of the sanding process, most of the wax has been removed and the finishes I use (Waterlox transparent finish or Behlen's Salad Bowl finish) don't seem to be affected.

—Al Vincent, Rochester, N.Y.

Methods of Work buys readers' tips, jigs and tricks. Send details, sketches (we'll redraw them) and photos to *Methods of Work*, Fine Woodworking, P.O. Box 5506, Newtown, CT 06470-5506. We will return only those contributions that include an SASE.

Cutting sheet goods with a circular saw

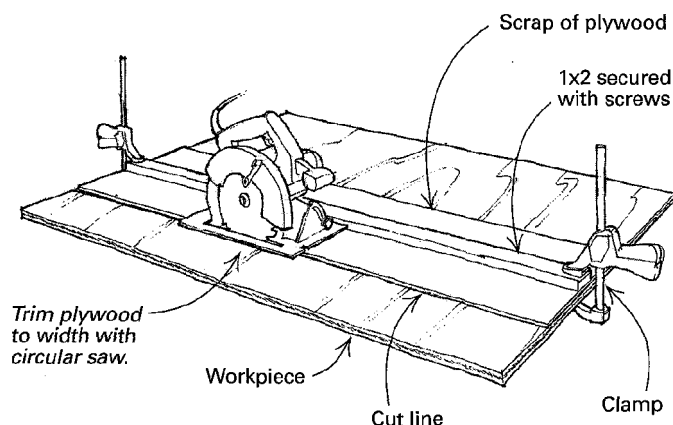

This fixture for cutting sheet goods with a circular saw is simple to make and gives accurate results. Attach a 4-ft. or 8-ft. length of 1x2 lumber to the middle of a piece of plywood that's the same length and about 12 in. wide. With the saw's base bearing against the 1x2, which is the fence of the fixture, rip off the edges of the plywood. You're done. Attach this jig to anything at any angle, putting the edge of the jig right on the cut line. You will know exactly where your saw will cut. Splintering is eliminated underneath the guide. Rip one edge at 45° if you like—it could come in handy.

The accuracy of this fixture depends on a straight fence, so pay attention when you attach the 1x2. Use a 4-ft. or 8-ft. straightedge, or just use the factory edge of a piece of plywood.

—Gary Allan May, Seattle, Wash.

Cove molding on the tablesaw

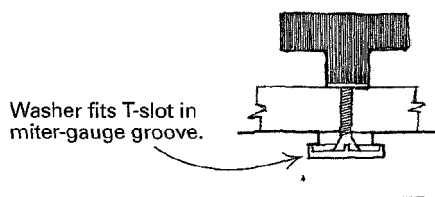
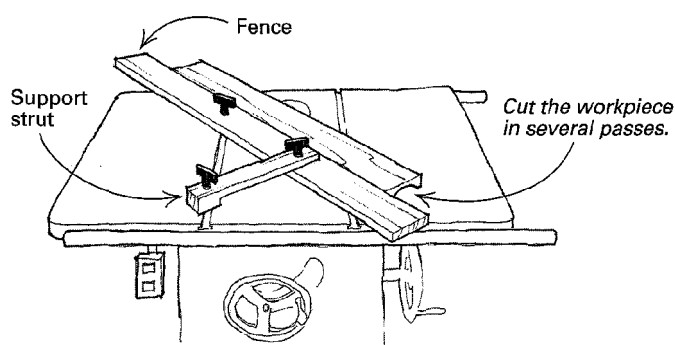

If you cut lots of cove molding on your tablesaw, this fixture will certainly repay the time invested in making it. The fixture requires a T-shaped miter-gauge slot, which is found on most newer table-

saws. To make the fixture, start by selecting a flat washer that fits the T-slot. Countersink two washers to fit the head of a machine screw. The washers and screws will provide hold-downs for adjusting and locking the fence in place. Select a clear, straight 1¼-in.-thick board for the fence. Assemble the fence and the support strut with the hold-downs and knobs, as shown in the sketch. You can buy the knobs or make your own.

To adjust the fence, set the sawblade at the full height of the finish cut. Move the fence to the near side of the blade. With a second straight edge held just tangent to the far side of the blade and parallel to the fence, vary the angle of the fence until you get the correct width of the cove between the fence and the straight edge. Tighten the knobs to lock the fence in place, lower the blade until about ⅛ in. protrudes above the table surface, and make the first pass to produce a small concave cut. Make successive cuts raising the blade ⅛ in. on each pass until you reach the desired cove depth.

—Roy H. Hoffman, Oriental, N.C.

Quick tip: To trace the outline of solid-wood inlays accurately, stick the inlay to the wood with double-faced tape, and trace the outline with a fine X-Acto knife. The tape will keep the inlay piece from slipping during tracing and will create a perfect cut line.

—Michael Fiedler, Clifton Heights, Pa.

Making wooden dowels

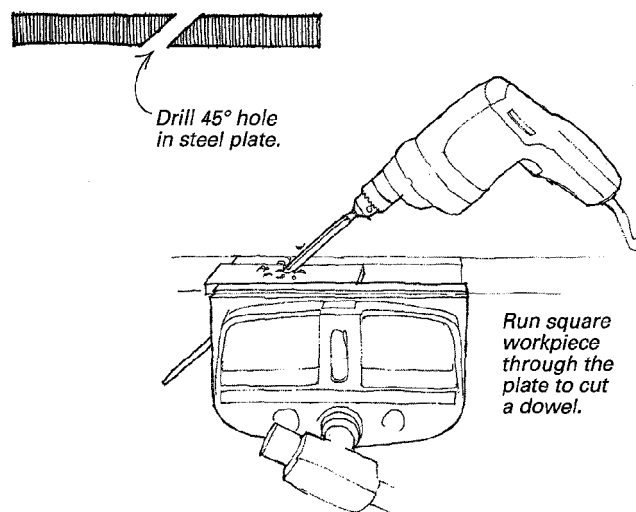

When I needed dowels in sizes and wood species not commonly available, I first tried making dowels the age-old way. I forced a square wooden rod, tapered on the end and chucked in a drill, through a hole drilled at 90° in a metal plate. This process was slow and unsatisfactory. So I drilled an angled hole through the metal plate, which created a sharp cutting edge on half of the circumference of the opening. The sharpened portion of the hole pares the wood off the rotating workpiece and cuts the dowel smoothly and quickly.

To drill the angled hole in the plate, start with a pilot hole, and then follow with the appropriate drill bit. You may have to clamp another piece of metal to the plate to provide enough support to get the bit started. This will keep the bit from skating off the

surface as you start drilling. Use steel plate that is sufficiently thick to act as a channel for the dowel—I used $\frac{3}{16}$ in.

To use the dowel maker, chuck a square blank into your drill. Taper the end by sandwiching the blank between two pieces of medium-grit sandpaper while the blank turns in the drill. Insert the tapered end into the hole in the plate, turn on the drill and push the blank through the hole. —Richard L. Runyan, Louisville, Ky.

Sanding block for inside corners

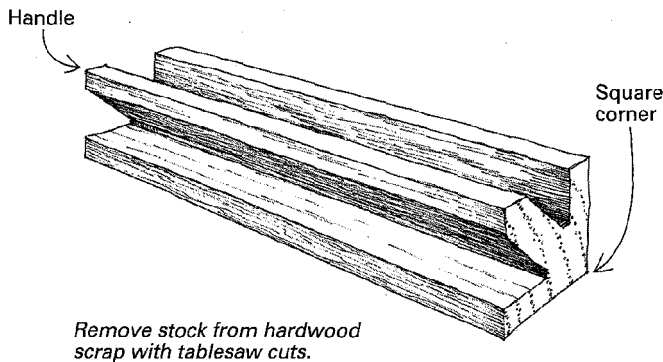

After gluing up a little shelving unit for my daughter's bathroom, I found that I needed to do a little light sanding in the corners. With a traditional sanding block, I could concentrate only on one surface at a time. So I made a sanding block that allows me to sand both surfaces of an inside corner at the same time.

Making the block takes only two different settings and four passes on the tablesaw. Starting with square stock, sized to fit your hand comfortably, make two cuts parallel to the outside edges. Then tilt the blade to 45° , reposition the fence and make two more cuts to define the handle. —Al Ching, Huntington Beach, Calif.

Burl inlay from tree bark

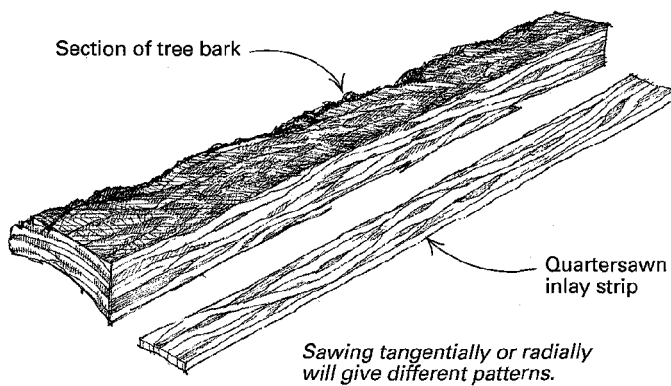

Most of the time, tree bark is wasted or turned into mulch. But not around here. I cut hemlock bark into $\frac{1}{8}$ in.-thick, $\frac{3}{4}$ in.-wide strips and inlay it into boxes and borders. When cut radially (quartersawn), the material shows a striped pattern. When cut tangentially (plainsawn), the grain has a curious burl effect.

To finish, wet-sand using 80-grit wet-or-dry sandpaper. This will

create a paste that acts as a filler. Continue sanding until nearly dry, letting the paper fill so it makes a smooth surface. When the bark veneer feels dry, coat it with as much lacquer sanding sealer as it will take. The result will look terrible at this stage. Let it sit for a few days, and then sand until the grain shows.

Add one light coat of sealer with a cloth, and finish up with extra-fine steel wool and wax. —Roger Russell, Anderson Island, Wash.

Quick tip: When spreading glue, I like to use a 3-in. paint roller. Its nap and diameter are perfect for applying the proper thickness of glue. The store-bought 3-in. rollers are relatively expensive, so I make my own by cutting 9-in. rollers into thirds. A single roller can be made to last several weeks by covering it with plastic wrap after each use. —Garrett K. Spitzer, Jamestown, N.Y.

Biscuit-joined edge-banding

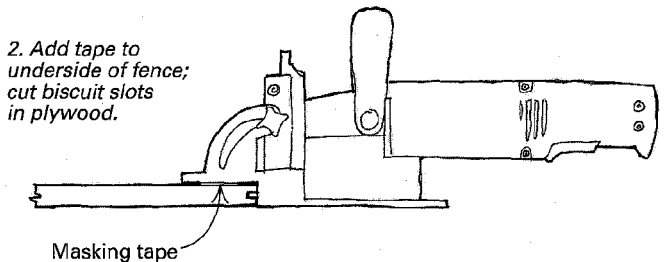
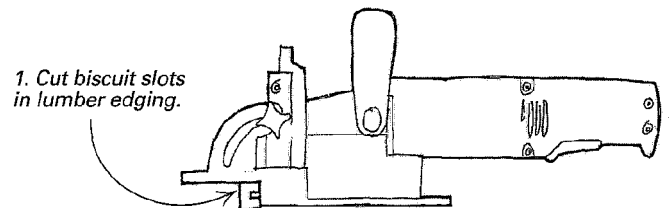
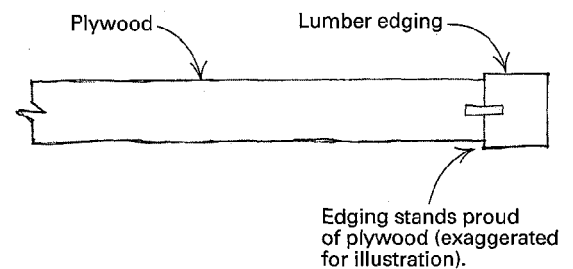

Biscuit joints are an effective way to attach solid-wood edging to plywood or medium-density fiberboard (MDF). But I like to offset the biscuit slots a bit to ensure that the edge-banding is slightly raised above the surface of the plywood. Otherwise, the edging will sometimes dip slightly below the surface of the veneer.

You may be tempted to offset the slot by adjusting the fence, but don't do it. It's not only time-consuming but risky, because the fence can sometimes end up slightly out of parallel to the first slot. Cut the slots in the edging first, and then add one or two layers of masking tape at the front and the back of the fence before you cut the slots in the plywood.

The masking tape will slightly offset the slots by just the right

amount. A skewed block or smoothing plane will trim the edging flush to the veneered plywood. —Ken Shaw, San Diego, Calif.

Miter clamping blocks

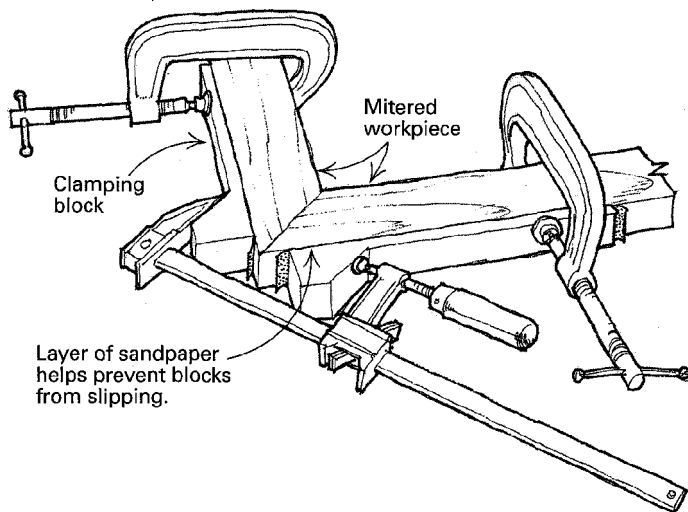

These auxiliary clamping blocks provide an easy and inexpensive way to clamp mitered workpieces. Bandsaw the blocks from a piece of hardwood scrap the same thickness as the stock being glued. For 90° corners, angle the face of the clamping block at 45°. For other odd angles, cut the face at half the angle of the finished joint.

To use, secure a clamping block to each side of the miter joint with a C-clamp. Add a strip of double-faced sandpaper between the clamp block and the workpiece. I make the sandpaper strips by gluing 180-grit sandpaper back to back. The sandpaper layer eliminates slippage with no harm to the workpiece. Spread glue on the joint surfaces, and clamp across the joint with a quick-acting bar clamp. —Ilmars Vilmanis, St. Petersburg, Fla.

Shop magnets from old speakers

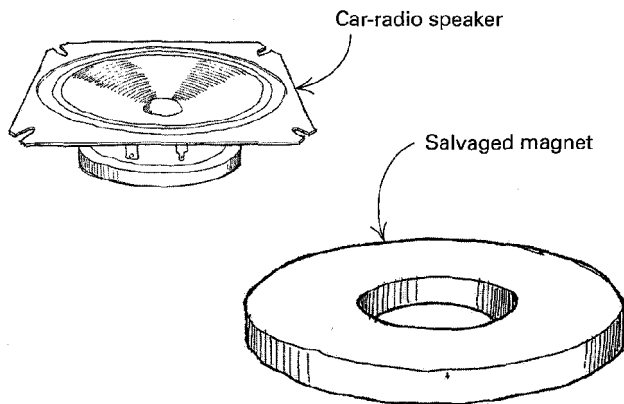

Old car-radio speakers yield various sizes of circular magnets, which can be handy in any shop. I use large ones to hold fences in place on the bandsaw and tablesaw and to secure pivot points in

place on the bandsaw table for cutting curved pieces. They're also good for holding steel rulers and wrenches in handy positions. The magnets can be slapped onto any convenient flat metal surface; the larger ones are very strong. To disengage them, slide them to an edge, and tilt them.

—Alan J. Wilson, Nelson Bay, N.S.W., Australia

Quick tip: The shank of a solid-carbide router bit makes an excellent burnisher for cabinet scrapers.

—Roger Russell, Anderson Island, Wash.

Low-budget composition castings

Latex mold material applied to similar section of frame

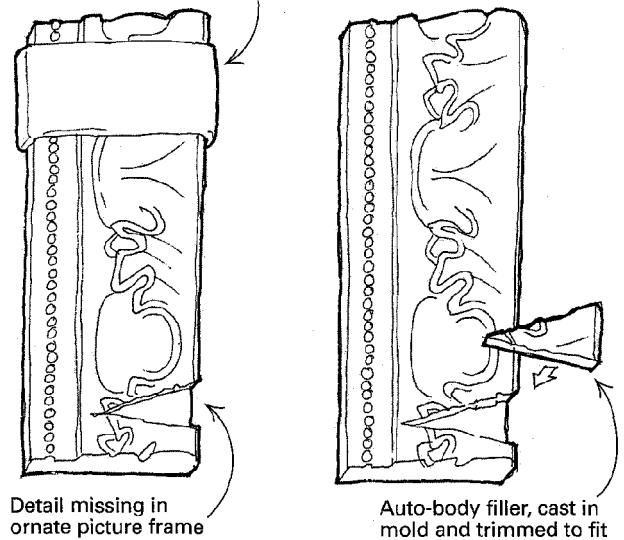

I recently restored a 75-year-old mirror frame that had much of the composition floral detail missing. Because of a tight budget, I had to find a low-cost way of duplicating the missing decoration. After several trials, I found a method that worked.

First make a mold of the existing decorative elements using latex mold material, commonly available at craft stores. Fill the mold with plastic auto-body filler. Just after the body filler starts to set up but is still in a plastic state, remove the cast from the mold. Trim the cast with a razor blade to make a piece that fits the missing section. The piece can be formed to fit a curved frame. Set the new piece in place, and weight it down with a bag of sand until it is fully cured.

To ensure the cast does not stick to the frame prematurely, sprinkle talcum powder on the frame. After the cast has cured, you can easily cement it in place with a new batch of body filler. Then you're ready for finishing. —Scott R. Carnegie, Downers Grove, Ill.

Methods of Work buys readers' tips, jigs and tricks. Send details, sketches (we'll redraw them) and photos to Methods of Work, Fine Woodworking, P.O. Box 5506, Newtown, CT 06470-5506. We will return only those contributions that include an SASE.

Knife-setting jig

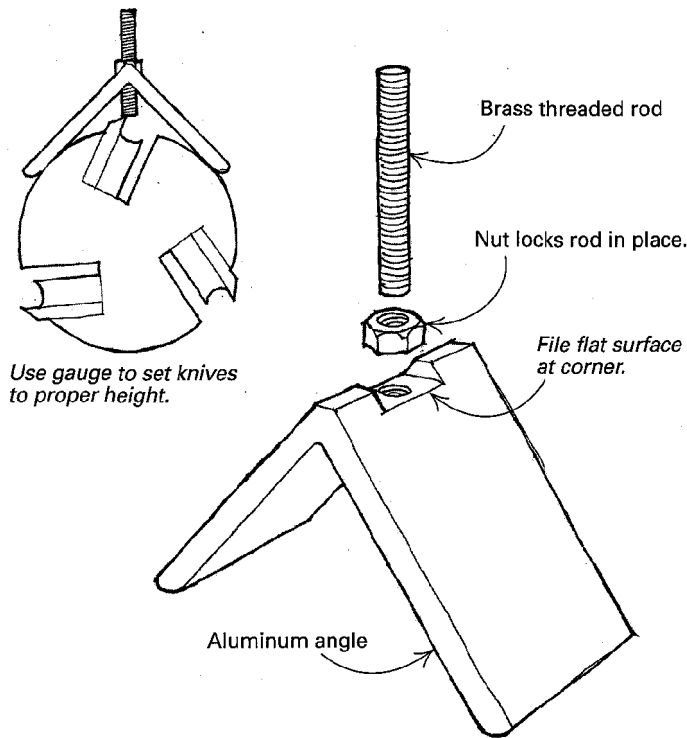

Here is a simple jig for setting planer or jointer knives. This aluminum and brass jig (both soft metals) will not damage the knives during the setting process.

To make the jig, cut a 1½-in.-wide section from 2-in. by 2-in. aluminum angle. File a flat surface on the corner of the angle. Using a drill press, drill through the flat spot, and tap the hole to fit the threaded brass rod. Screw a piece of the threaded brass rod in the hole, adjust the height and lock the rod in place with a jam nut, as shown in the drawing above.

These jigs are quick and inexpensive to make, so you can have one for each machine, fixed at the proper setting.

—Ronald E. Young, Chattanooga, Tenn.

Holding router bits with clay

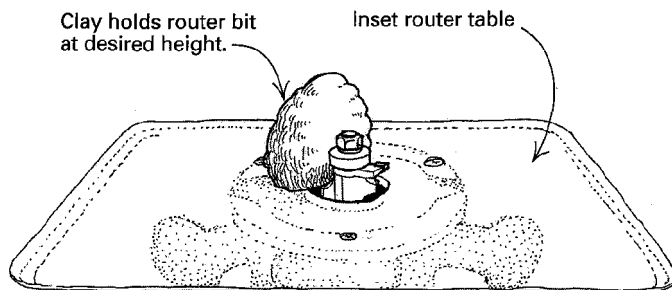

With my router mounted upside down in a router table, I use a golf-ball size blob of children's clay or modeling compound to temporarily hold a router bit in place while I tighten the collet nut.

The material has just the right consistency to do this job, and it will not leave a residue on the router bit or the table. Pressed onto the router table and against the bit, the clay acts as a third hand to keep the bit from dropping too far into the collet.

This method gives me better control over making fine adjustments to the bit height than I get by dialing the router up and down. I store the material in a plastic bag to keep it from drying out.

—Bob Kelland, St. John's, Newfoundland, Canada

Quick tip: My shop is heated only when I'm using it. So to keep my paints and stains from freezing, I use an old junk refrigerator heated by a 40-watt bulb. Even when the outside temperature is in the teens, the heat from the bulb keeps the inside of the "defrigrator" around 70°F. I guess the old question "will the light go off when the door is closed?" doesn't apply in this case.

—Jeff Householder, Vincent, Ohio

A micro-adjustment for the saw fence

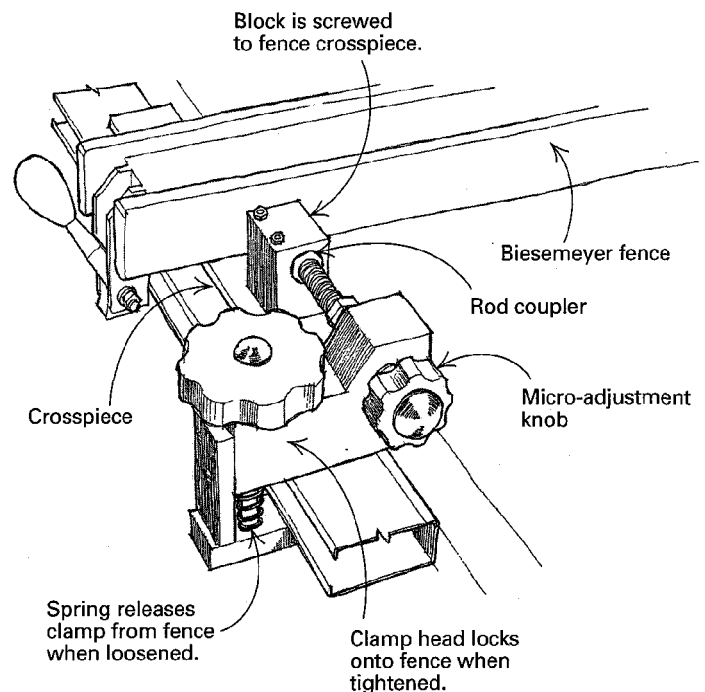

This micro-adjustment fixture enables you to fine-tune the settings on a Biesemeyer-style tablesaw rip fence. The fixture consists of two main parts: a block that attaches to the cross piece of the rip fence and a clamp head that locks onto the front rail of the fence.

The adjusting device itself is a 6-in.-long, ½-in. carriage bolt with a wooden knob glued to its head with epoxy. The bolt runs through a slightly oversized hole in the clamp head and into a rod coupler that has been press-fit into the block. The length of the rod coupler, as opposed to a standard hex nut, helps prevent the adjusting bolt from binding as it is turned. The range of adjustment is about 1 in., more than enough for most applications.

To use the device, leave the fence-locking lever up, and then clamp the head to the fence. Twist the micro-adjustment knob as necessary to locate the fence where you want it. Then lock the

fence in place with the regular locking lever. The whole setup works smoothly and is a pleasure to use.

—Timothy D. Anderson, Chippewa Falls, Wis.

Overhang marking gauge

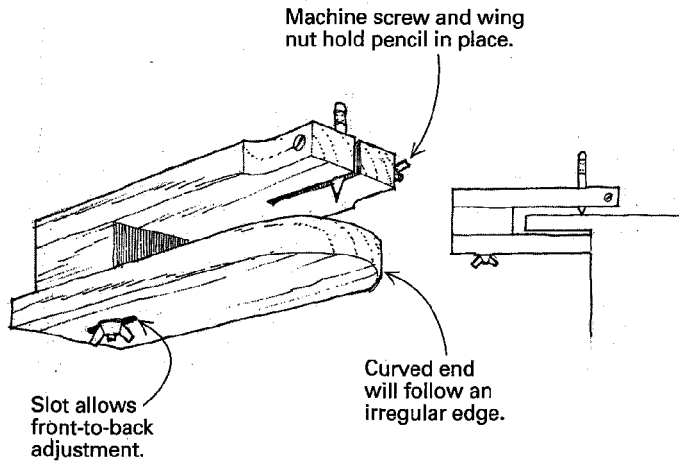

Originally, I made this jig to mark some laminate slightly oversized for trimming. Then I realized how handy the jig would be for other tasks, like marking a cutting line on the edges of an irregular deck. For a one-time job, it's easy to make up a jig with a few scraps held together with a C-clamp. Or you can make a more permanent adjustable version, as shown in the drawing above.

—Leon G. Wilde, Andover, Mass.

Foolproof drawer face installation

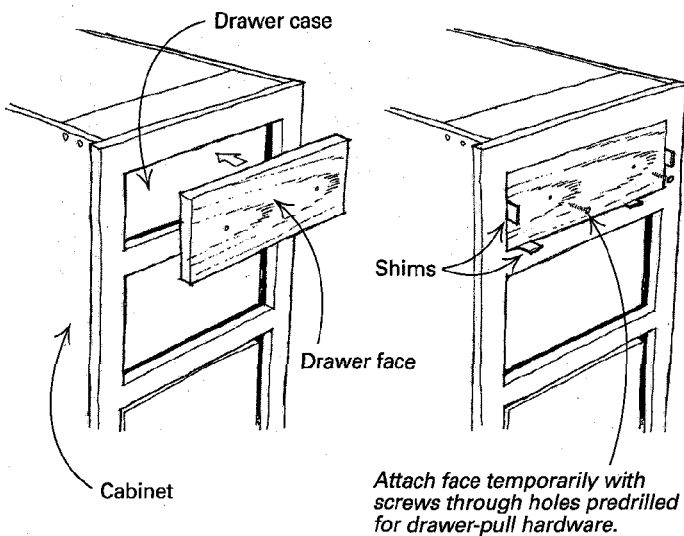

Here's a method for accurately installing applied drawer faces. It replaces the normal method that requires three hands, vigorous cursing and a lot of luck.

The method works as long as you are using drawer-pull hardware that is mounted with screws through the face into the drawer case. Install the drawer case in the cabinet. Drill two holes for

the hardware through the drawer face, and place it against the drawer case, shimming as necessary. (I use strips of plastic laminate for shims.) With the face in position, drive screws through the hardware holes, temporarily attaching the face to the drawer case in the correct location.

Pull out the drawer, and permanently attach the face with screws through the inside of the drawer case. It's a good idea to clamp the face to the drawer case to prevent any slight movement when you drive the screws. After removing the two holding screws, you can use the predrilled hardware holes as guides to drill through the case for screws that secure the drawer pulls.

—Peter Rippon, New York, N.Y.

Quick tip: Keeping the threads of clamps and woodworking machinery clean and greased is not always practical. Another alternative is to clean the threads with a wire wheel and then spray them sparingly with Sandaro's TopCote product. This is a spray lubricant that leaves a dry, waxy film that stays cleaner than greased threads.

—Robert Vaughan, Roanoke, Va.

Sanding block for small chamfers

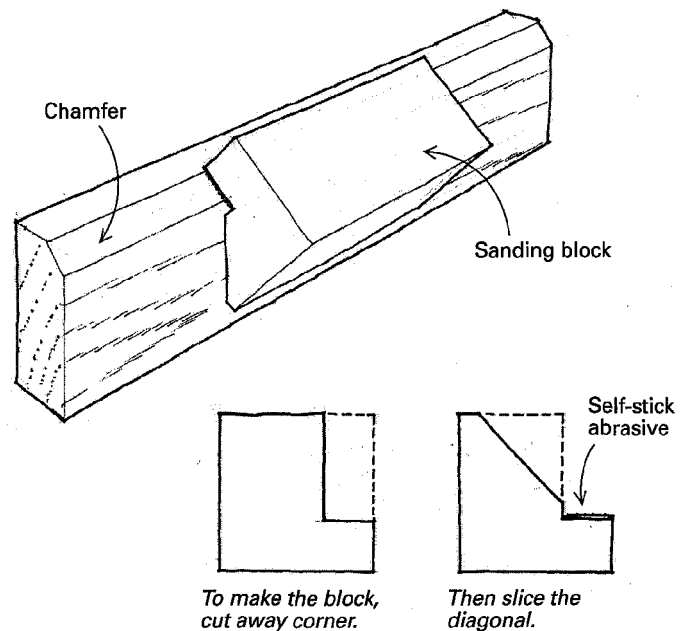

Here's how to sand a small chamfer without rounding it over. Make a sanding block by first cutting away one corner of a hardwood block. Then cut through the body of the block at 45°. Add self-stick abrasive paper along the edge of the block, as shown.

—Paul Davis, Renton, Wash.

Rubber mats in the shop

My dairy farm friends contributed a rubber mat to my new workshop. These pads are about 3/4 in. thick. They are made from shredded car tires and are used in dairy barns to protect cows' legs from injury on cold and wet floors. I find that the pads work equally

well for human legs: They provide relief for tired leg muscles and increase the length of time you can stand on your feet. Another benefit is that a cast-iron plane or a spokeshave dropped on the floor will bounce harmlessly, rather than shatter.

If you live in dairy country, the mats are commonly available at farm supply and co-op stores. Elsewhere, call Global Rubber (610-640-4292). They can ship you a mat directly or direct you to a distributor in your area. The mats cost \$25 to \$50 and weigh up to 100 lbs. each, depending on size.

—Richard Bird, Belleville, Ont., Canada

Making dados with a dog board

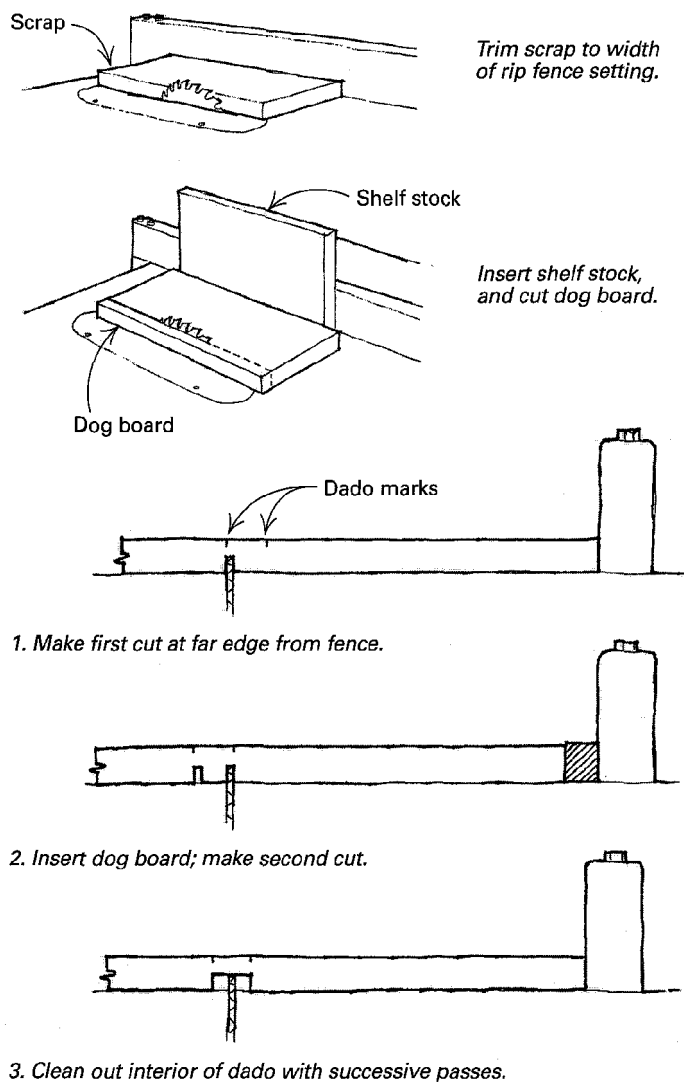

I devised this method so that I could cut a few dados quickly and accurately without having to adjust a set of dado cutters to an exact width with paper shims. The key to this method is a strip of scrap, which I call a dog board, that shifts the workpiece the exact distance needed to cut both sides of the dado.

To make the dog board, trim a piece of scrap to a random width with the rip fence so that the sawblade cuts a clean surface along

the edge of the scrap. Insert a piece of the shelf stock between the scrap and the fence. Run the scrap through the saw, and save the cutoff. You now have the strip—the dog board—that will move a workpiece over the thickness of the shelf stock, minus a sawkerf.

To use the dog board, mark the dado locations on the workpiece, and set the rip fence and blade height for the first cut, the one farthest from the rip fence. Make the cut. Now insert the dog board between the workpiece and the fence, and make the second cut. Nibble out the waste between the two cuts with successive passes. The dado will fit the shelf stock perfectly.

I wouldn't recommend this technique for long production runs. But when you need to cut only three or four dados, it will definitely save you time.

—James Kimbriel, Batavia, N.Y.

Quick tip: I have several 10-in. sections of railroad track in my shop that I use as anchors for all sorts of chores. They are especially useful at the radial-arm saw, where I use a section to hold down a row of identical pieces of wood for cutting dados. They serve like another pair of hands, and they're more predictable than a shop assistant.

—Ted Welchert, Tucson, Ariz.

Retracting shop table

Closed position

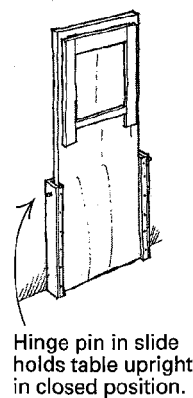

Open position

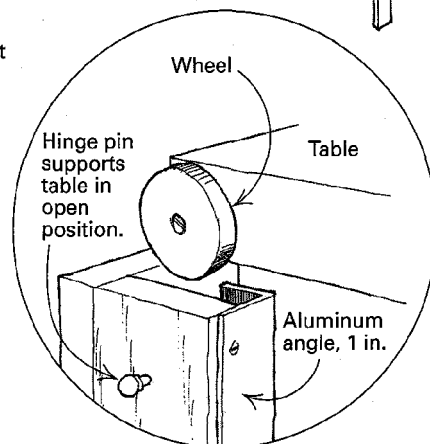
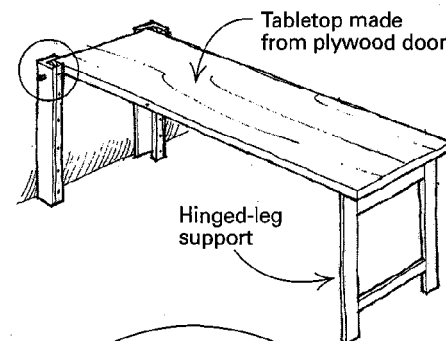

I've been using a retractable table in my small shop. It serves as an assembly platform for cabinets and furniture and as a drawing table. It is large enough to accommodate the full-sized drawings that I use with my projects.

The tabletop is an old flush door (32 in. by 84 in.) fitted into a slide that holds it upright against the wall when not in use. The

table swings down to a comfortable working height that is the same height as my radial-arm saw table. I use the table for additional support when I'm cutting long boards.

I made the slide by attaching aluminum angle to the front edge of two wooden wall brackets. The slide captures 2-in. wheels that are screwed to the back corners of the door, so the door opens from a stowed position smoothly and safely. When stowed in an upright position, the door is locked in place with some pins I borrowed from a pair of door hinges. The hinge pins slide under the wheels to hold the door at the right height when it's in an open position.

—*Dave Gillis, Milwaukee, Wis.*

Positioning laminate over contact cement

When you apply contact cement to a large piece of plastic laminate and a substrate, it's a challenge to position the laminate accurately, especially if you work alone. I've found that using metal shelf standards work well. Spaced about 16 in. apart, they keep the laminate from coming into premature contact with the cement-covered substrate (after which it won't move). Yet they are thin enough to allow very accurate positioning.

When the laminate is positioned correctly, press the center down first to keep the piece from shifting. Then lift one end at a time, remove the standards and press the laminate from the center out. Any glue residue on the standards will wipe off easily with lacquer thinner or acetone.

—*Daniel Silverman, Wellfleet, Mass.*

Cutting dowels with a tubing cutter

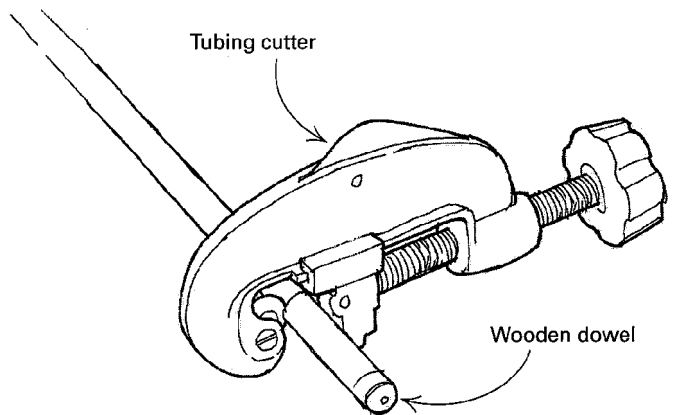

I use a tubing cutter (the kind plumbers and electricians use) to cut wooden dowels. Roll the cutter around the dowel a few turns, and snap off the dowel. For cutting just a few dowels, this is faster and more accurate than using a saw. —*Howard Moody, Upper Jay, N.Y.*

Methods of Work buys readers' tips, jigs and tricks. Send details, sketches (we'll redraw them) and photos to *Methods of Work*, Fine Woodworking, P.O. Box 5506, Newtown, CT 06470-5506. We will return only those contributions that include an SASE.

Box assembly jig

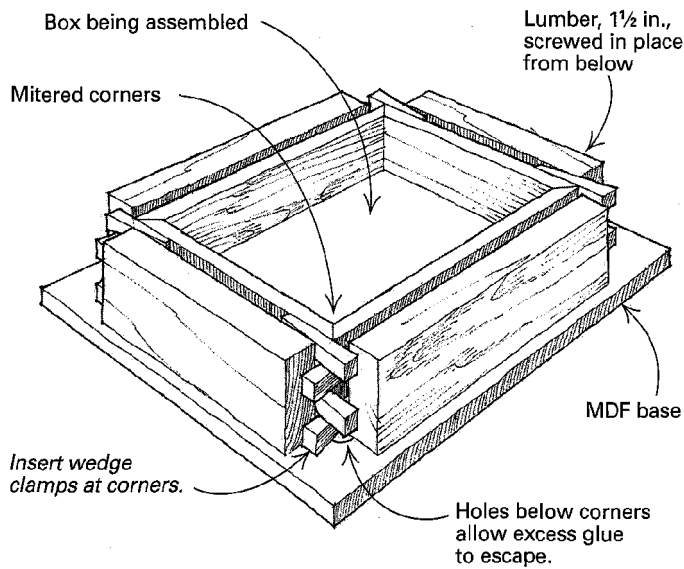

A commission for six identical boxes led me to develop this assembly jig. The jig consists of four 1½-in.-thick pine supports mounted to a ¾-in. medium-density fiberboard (MDF) base with long, beefy screws. I cut each support ½ in. shorter in length than the corresponding box side to allow space into which I drive wedges that do the clamping.

To use the jig, I apply glue to the four mitered corners of the box and place the box in the jig. Then I insert pine wedges between the supports and the box sides to compress each corner of the box. A 1-in. hole in the base directly under each corner keeps excess glue from bonding the box to the base.

With this jig, I can glue and assemble a box in less than 10 minutes with virtually no racking. The corners are tight and uniform.
—Mark Maiocco, Spotsylvania, Va.

Un-sticking machine parts

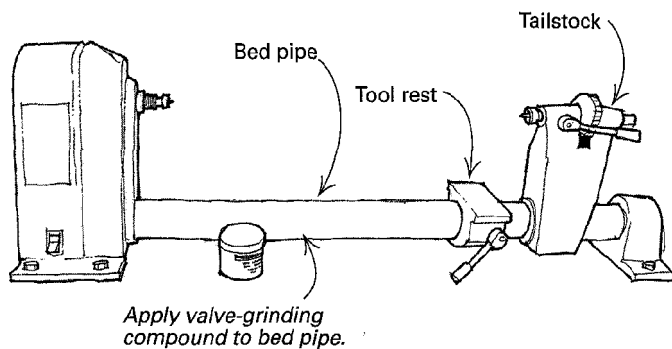

The tool rest and tailstock on my lathe were difficult to slide back and forth on the cylindrical bed. At times, I had to tap them with a mallet to make an adjustment. I finally solved the problem with automotive valve-grinding compound.

I applied a thin coating of the grease-based compound all over the bed pipe. With the levers unlocked, I moved the tool rest and the tailstock back and forth over the bed, essentially grinding off the high spots that were causing the trouble. I kept up the grinding action until the fixtures moved freely on the bed.

After cleaning off the compound with a degreaser, I applied car wax to the entire bed. I suspect this same procedure would loosen up a stubborn tablesaw rip fence as well as solve other similar machinery problems around the shop.

—Bob Kelland, St. John's, Newfoundland, Canada

Quick tip: For an improvement over waxed paper or newspaper to protect your work surface, try some mirrored Mylar film used on windows. The stuff is nearly indestructible, comes in different widths, and glue drips and finish spills wipe right off. The material is a bit pricey, but you might be able to buy some leftovers at a discount from a car-windshield or glass supplier.

—Ben R. George, Long Beach, Calif.

Aid for marking dovetails

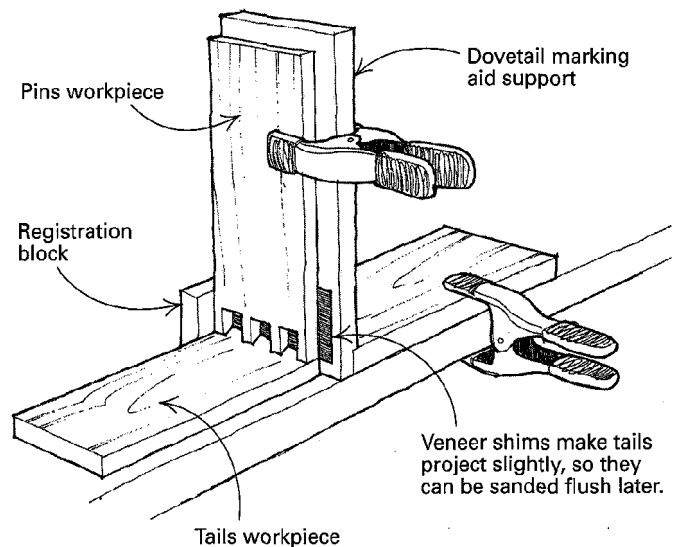

When making dovetails by hand, it is easy to introduce errors while marking the outline of the tails from the pins. This is the sort of three-handed job that requires keeping the workpieces aligned perfectly in two different directions while holding everything rock-steady. It further complicates things if you want to shift the registration slightly so the tails will be a bit long for sanding off later.

I have found that by using a simple right-angle support, I can reduce these marking errors. The support is simply a couple of scrap pieces screwed together at 90° with a stop block added on one edge to align the edges of the two workpieces. I clamp the support to the workbench, align the two workpieces and clamp the vertical workpiece to the support with spring clamps. I place a piece of veneer (about 1/32 in. thick) behind the vertical workpiece so the tails will protrude a bit.

I like to mark lighter woods with a pencil that has a chisel point sharpened down to the center of the lead on one side. This allows

precise tracing of the pin outline. On darker woods, a knife scratch is easier to read.
 —John M. Van Buren, Herndon, Va.

Pivoting panel mover

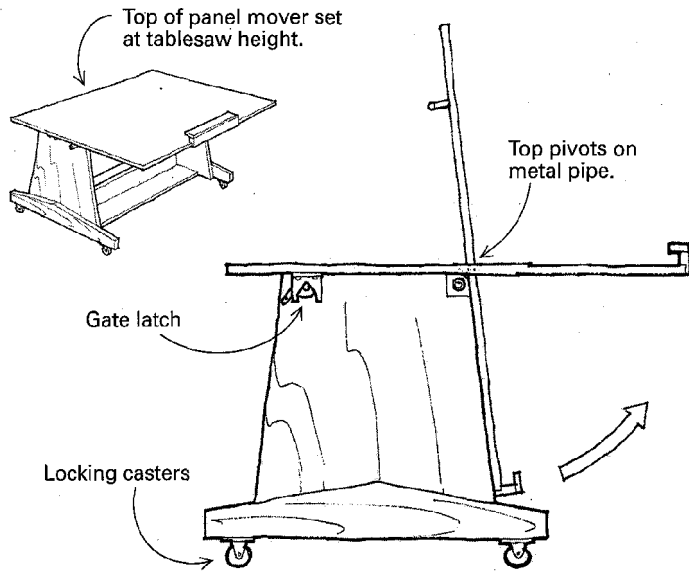

This panel mover enables one person to easily load a full 4-ft. by 8-ft. sheet of plywood, move it around the shop, raise the panel to horizontal and lock it securely at the right level to push it through the tablesaw. The top pivots on a metal pipe mounted through holes in the vertical supports and into lumber attached to the underside. The unit also serves as a fine movable workbench. One unique feature of the fixture is the use of a gate latch to lock the pivoting panel at horizontal. Other construction details are shown in the sketch.
 —David Carter, Victoria, B. C., Canada

Adjustable shopmade clamps

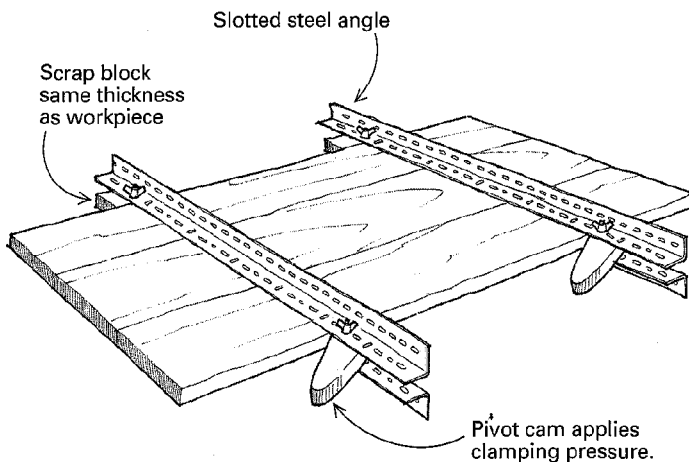

Woodworkers needing to edge-join boards on a regular basis should consider using slotted-steel angle to construct a clamping

jig. The slotted angle is available in a variety of weights and strengths for use in shelving systems in libraries and warehouses. Holes or slots are punched along the length of the material for a variety of bolt placements.

A clamping jig can be made by fixing two pieces of the angle together with bolts and wing nuts at each end. One bolt secures a fixed spacer the same thickness as the planks to be edge-glued. The other bolt holds a cam clamp, also of the same thickness, which applies pressure to the plank edges when the whole clamp is assembled.
 —A. W. Clarke, Moonta Mines, Australia

Quick tip: I like to unplug my stationary power tools when I leave my shop. So I tied a short length of orange plastic surveyor's ribbon to the plug end of each cord. A quick glance around the shop at the end of the day reveals any tools that are plugged in.

—Croxtton Gordon, Machipongo, Va.

Using a belt sander as an edge sander

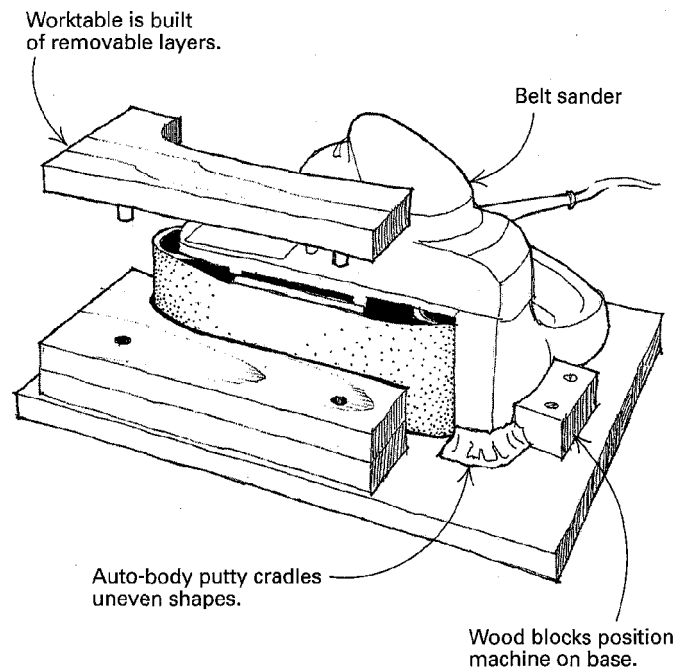

To mount a portable belt sander for edge-sanding, start by placing the sander on a piece of 3/4-in. plywood so that the platen is square to the plywood. Attach small blocks to keep the sander in position, and press small amounts of freshly mixed auto-body putty under and around the sander to form a customized cradle. Be careful not to build up the putty in such a way that would prevent the sander from being removed from the cradle. Apply the putty in thin layers, and allow each layer to set before applying the next. Be sure to coat the sander with oil, or enclose it in a plastic bag to prevent the putty from bonding to the tool.

After the cradle is complete, trim the base and add a worktable. I made one by stacking several scraps of wood in front of the belt, as shown in the sketch. The layers allow me to use the full width of the belt and can be shaped around the front of the belt to provide some curve sanding. Each of the layers of wood has

two dowels in the bottom that engage a matching set of holes in the layer below it. —Omar V. Showalter, Harrisonburg, Va.

Quick tip: After running out of commercial pitch remover to clean my sawblades, I gathered some suggestions for home remedies from a newsgroup on the Internet (rec.woodworking). I tried almost all the suggestions I received. One of the most effective is to place the blade in an old cake pan, sprinkle baking soda on it and add a teapot full of boiling water. It works amazingly well.

Dark green, professional 409 glass cleaner and automotive carburetor cleaners both remove heavily burned pitch from router bits and sawblades, and they're much less expensive than commercial pitch removers. —Mike Vincent, Littleton, Colo.

Blade changing made safer

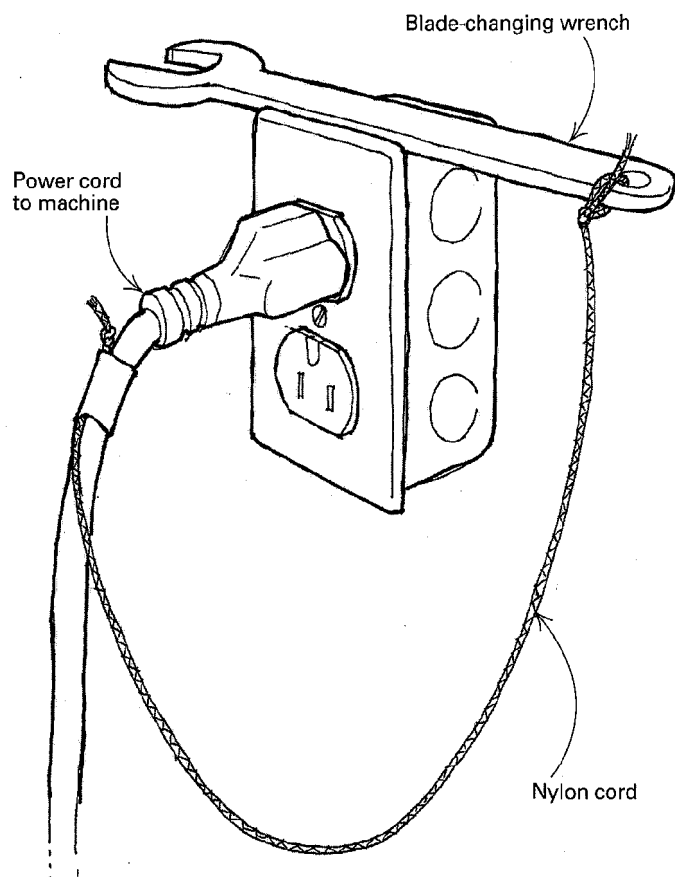

This simple arrangement ensures that I never forget to unplug my machines before changing blades or cutters. I've tethered each blade-changing wrench to the power cord for that machine, close to the plug. This means that to change my sawblade, for instance, I must pull the plug and take the wrench and the plug to the saw. For the tether, I use a length of thin nylon cord about 18 in. long. I knot one end of the cord through a hole in the wrench and tape the other end to the cord.

Because I have surface-mounted electrical outlets, I can set the wrench on top of the outlet. With flush outlets, you could use a small nail or screw to hang the wrench so its weight is not on the cord.

You'll get a few very desirable bonuses from this idea: You won't have the disaster of switching on the machine with the blade-changing wrench still engaged, and you'll never misplace the wrench. —B. Butters, Doncaster, South Yorkshire, England

Quick tip: I have reached the age where getting down to retrieve dropped nails and screws is becoming more and more difficult. So I made a magnetic sweeper by attaching a 12-in. length of flexible magnetic strip to a wooden block fitted with a handle.

—Don Anderson, Sequim, Wash.

Cutting wedges

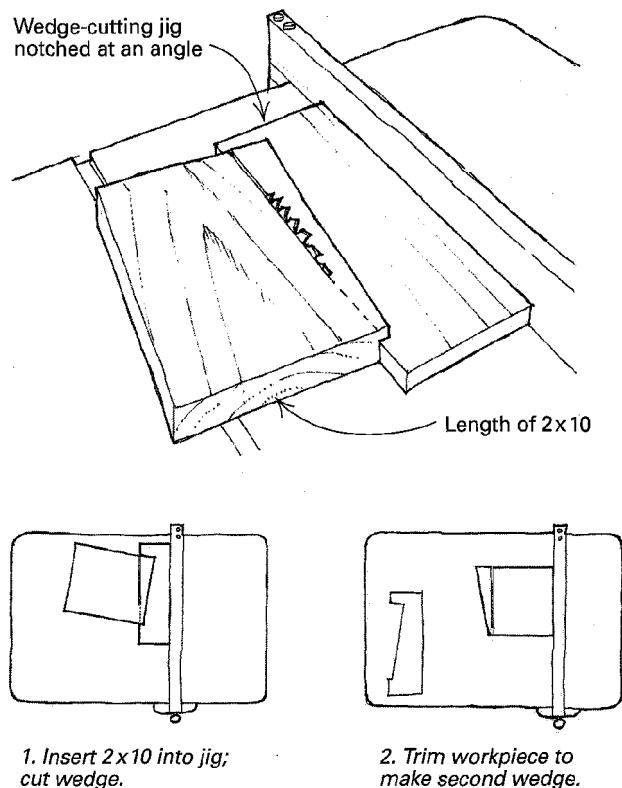

I just glued up three large cherry panels using the vertical press described by Jim Tolpin (*FWW* #112, pp. 58-59). The press works great but relies on a lot of wedges. Here's how I cut the wedges quickly and accurately with a simple jig.

Start by notching a scrap of plywood with the desired wedge shape, as shown in the sketch. Cut a short length from a 2x10 to fit the notch in the plywood snugly. Place the workpiece into the notch, and run the plywood against the fence to slice off a wedge. Remove the wedge from the jig, and run the uncut edge of the 2x10 against the fence to produce a second wedge. Continue this sequence of cuts until the 2x10 is too small to handle safely.

—Karl Kirchofer, Seattle, Wash.

Methods of Work buys readers' tips, jigs and tricks. Send details, sketches (we'll redraw them) and photos to *Methods of Work*, Fine Woodworking, P.O. Box 5506, Newtown, CT 06470-5506. We will return only those contributions that include an SASE.

Methods of Work

EDITED AND DRAWN BY JIM RICHEY

Using a carving gouge for surface repairs

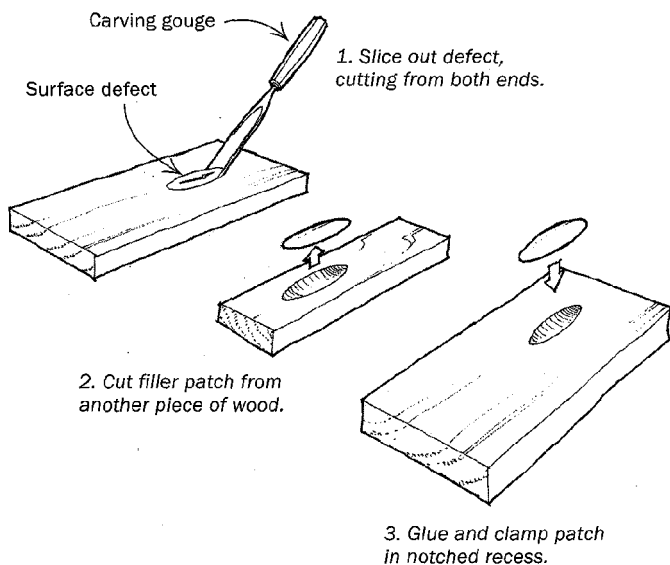

Here's how to repair voids, scratches, chips or small dents in wood that are parallel to the grain. Pick a carving gouge that will take a cut bigger than the void being filled. Start from both ends of the defect, and slice into the wood toward the middle of the defect. Remove the gouged waste piece.

On another piece of wood with matching grain, slice out a filler strip of wood slightly deeper than the gouged void. Cut the filler strip from both ends, just as you did the defect. Glue and clamp the filler strip in the void and sand flush. It makes a nearly perfect repair without obvious gluelines, especially if you use a gouge with a deep, rather than a shallow curve.

—Gary Rosquist, Salt Lake City, Utah

Humidity stick

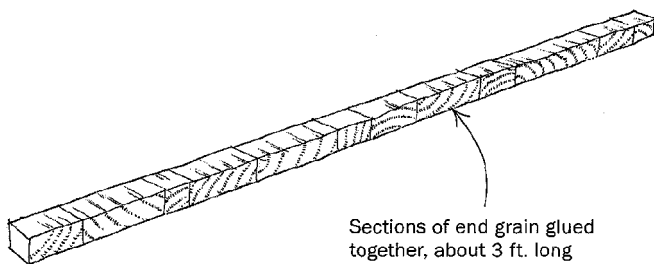

To judge the humidity in my workshop and to determine the approximate gaps necessary for drawer clearance and panel movement, I keep a device I call a humidity stick hanging on the wall. It is simply a number of scraps of end grain, about 1 in. wide by 1 in. thick, glued together to form a stick 3 ft. long. Every few weeks, I measure the length of the stick and write the measurement on the front side, along with the date.

This historical data helps me to estimate the amount of cross-

grain wood movement I should experience from season to season. A bit of quick math will scale the movement in the stick to the dimension of a furniture part. The stick also gives me a physical gauge that helps to estimate where the wood in my shop stands in the yearly expansion and contraction cycle.

—Garrett K. Spitzer, Jamestown, N.Y.

Making bending molds from router-cut plywood

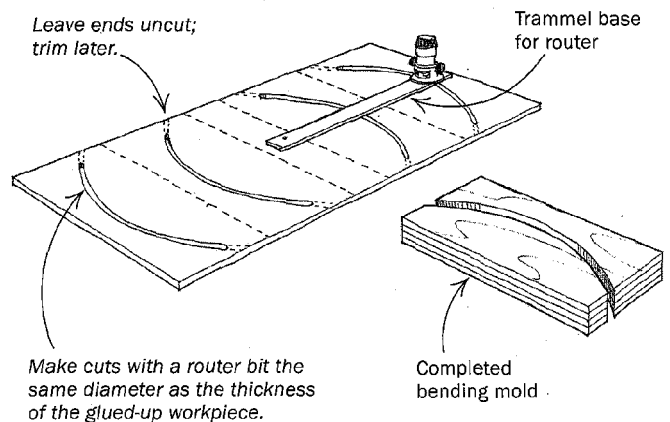

When I made some plywood forms to laminate a curved headboard, I discovered this trick. If you cut the forms with a router bit the same diameter as the thickness of the laminated workpiece, you will automatically have the slightly different curves needed for the inside and the outside molds. They will fit perfectly when clamped up.

To make a matched pair of bending forms, screw a wooden bar to your router base to act as a trammel. Mark a centerline on a sheet of plywood, and lay out the locations of the slots. Rout the arcs, leaving a small piece uncut at the end of each radius to hold the sheet together. When done, cut the pieces to size. Stack the cut parts for inside and outside molds, and screw them together.

—Ken Shaw, San Diego, Calif.

Lining shelves with felt

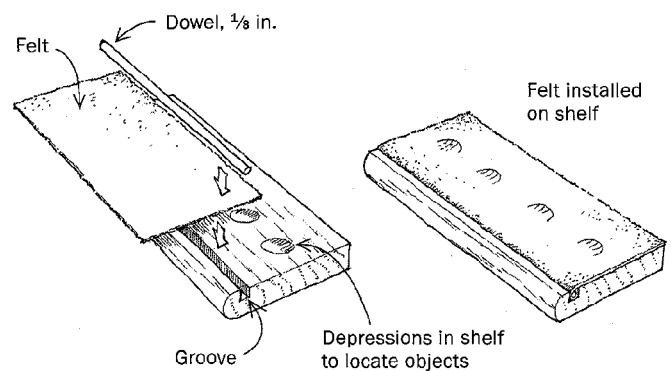

When I accepted a request to build a display case for 100 golfballs, I had no idea how to line the shelves with felt. I did know, though, that I did not want to glue the felt to the shelf with a raw edge

Methods of Work (continued)

showing at the front. I came up with a method that works well.

I cut the shelving pieces, bullnosed the front, drilled shallow indentations for the golf balls (with a modified spade bit ground to shape), and stained and finished all exposed surfaces. Then I cut a groove about 1/2 in. back from the top edge of each shelf to accept a 1/8-in. dowel and two thicknesses of felt. After spreading a light coat of white glue in the groove, I folded the edge of the felt around the dowel and pressed it into the groove. I used a wooden wedge to seat the dowel where needed. Later, I glued the flap of felt to the shelf and trimmed the sides and back.

—Carl Reiser Sr., Ada, Mich.

Quick tip: To make a flush-cutting saw for plugs and dowels, I ground the set off the teeth on one side of a hacksaw blade. To use, I hold the sawblade with my fingers and place the blade's teeth against the dowel with the smooth side down on the workpiece.

—R.B. Himes, Vienna, Ohio

Jig for making beveled notches

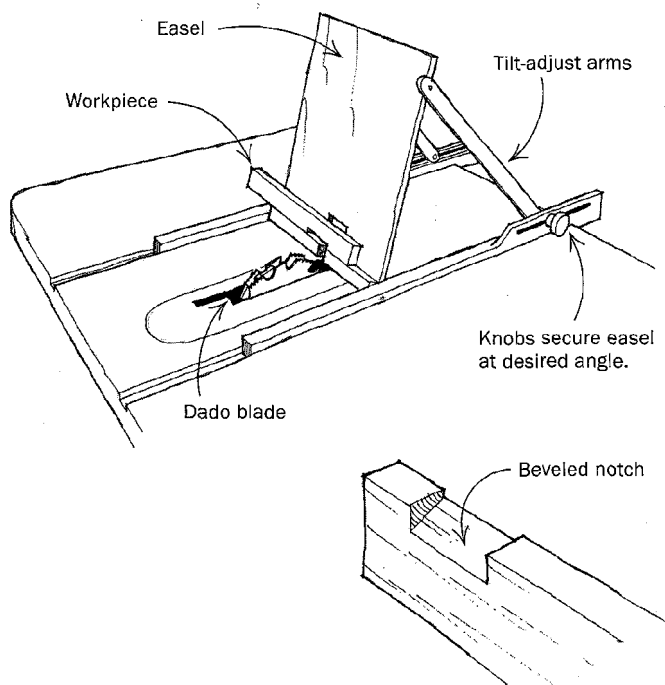

For a recent production run of toys, I had to cut several beveled notches on each toy. My first thought was to use a simple beveled block attached to my miter gauge that would tilt the workpiece at the appropriate angle for a dado-blade cut. But then I realized I'd have to try several different angles when building the prototype, requiring many trial-and-error setups. So to save time, I designed the variable-angle, notch-cutting jig shown in the drawing.

The jig consists of a sliding frame that runs along the miter-gauge slots in the tables. The frame includes a work-support easel mounted on a tilt-adjust mechanism. When the easel is set at the desired angle, the tilt-adjust mechanism clamps it in place.

I adjust the dado blades to the proper height for the desired

depth of cut, and push the whole frame forward to make the cut. I slide the workpiece to the left or right and make another pass to widen the cut of the beveled notch.

—Jack Hall, Newport Beach, Calif.

Quick tip: There is no better tool to use for setting the fence on a tablesaw than a good machinist's stainless-steel rule that has a satin finish. My favorite is a Starrett 18-in. rule. It has four sets of gradations: 32nds, 64ths, 10ths and 100ths. I keep it clean with a dish-washing abrasive, so it's always bright and readable.

—Donald R. Lewis, Owasso, Okla.

Enlarging routed dados

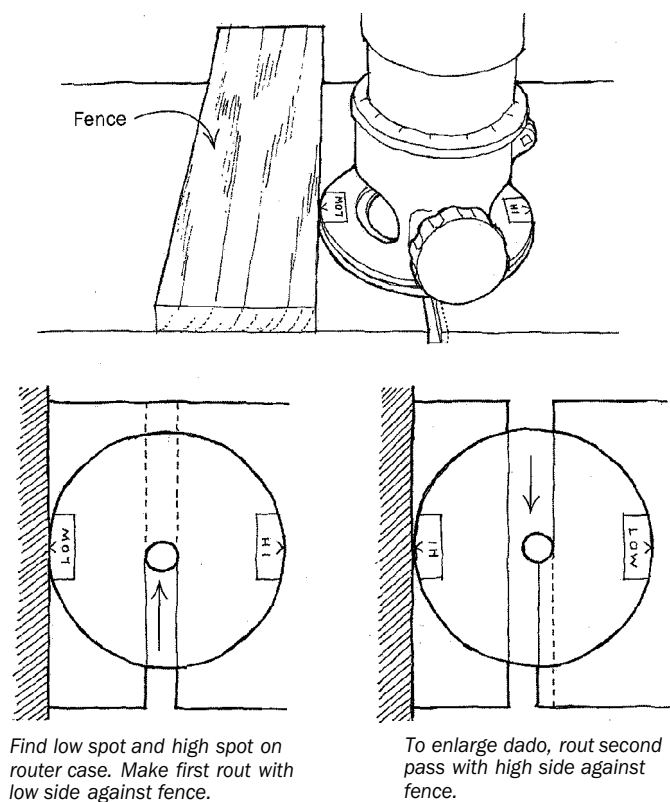

Find low spot and high spot on router base. Make first rout with low side against fence.

To enlarge dado, rout second pass with high side against fence.

I recently had to rout a series of dados slightly wider than the router bit into some large panels. To accomplish this, I took advantage of my slightly eccentric router base. In relation to the collet, most router bases are less than perfectly centered.

Through trial and error, using pieces of scrap, I determined the high spot (the one farthest from the collet) and the low spot (the one nearest to the collet) on the base. I marked these locations with masking tape. I also marked several intermediate locations between high and low.

With a fence clamped in place, I made a single pass, keeping the low spot against the fence. Then I rotated the router base, placing the high spot against the fence, and made a second pass to enlarge the original dado slightly. The second pass added about 1/32 in. of width to the dado—just the right amount for my application. If

Methods of Work (continued)

your router base is one of the few that happens to be concentric, you can accomplish the same effect by adding layers of tape as shims on the outside edge of your router base.

—Scott Bowen, Salt Lake City, Utah

Brad box

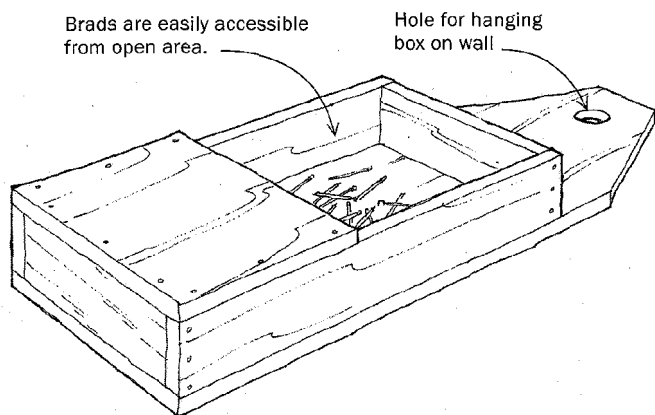

Here's an idea I got out of a patternmaking handbook published in 1907. Make up brad storage boxes from thin scrapwood in sizes to suit, as shown. When laid horizontally on the bench, the brads are accessible in the open area. When hung on the wall, the brads will fall into the lower portion of the box.

—Anthony Guidice, St. Louis, Mo.

Approximating 64ths on a tape measure

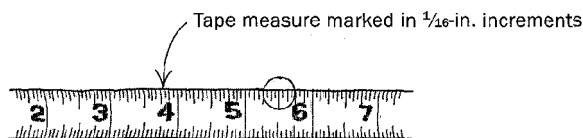

I usually carry a tape measure graduated in $\frac{1}{16}$ -in. increments. A fellow named Drummond Reed taught me a system to see and to communicate measurements down to $\frac{1}{64}$ in. If the measurement

falls between two marks, call it plus or minus. If it falls a quarter of the way between two marks, call it long or short. With a little practice, you can see the measurements at a glance.

This system is accurate, and it eliminates the need for hard-to-see tiny lines and complicated measurements expressed in 32nds or 64ths.

—Gary Allan May, Seattle, Wash.

Quick tip: To quickly identify lathe tools on a shaving-covered lathe bed, paint the ends different colors to designate different functions: for example, green for skew chisels and yellow for parting tools.

—Robert M. Vaughan, Roanoke, Va.

Double miter-gauge jig for cutting angles

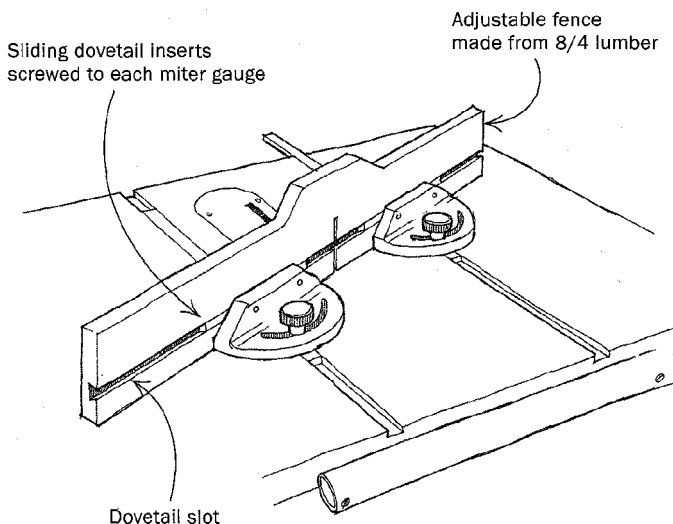

Frustrated by the inaccuracies and trial-and-error test cuts that seem to go with using a regular miter gauge on the tablesaw, I had set the gauge aside and relied on dozens of auxiliary fences preset to specific angles. But now, after years of not using that one miter gauge, I discovered all I really needed was two miter gauges connected by a hefty fence.

To make the jig, I set one miter gauge in each slot and screwed a 2-in.-thick oak fence, 2 in. wider than the maximum height of the blade, to both of the gauges. To allow the fence to move slightly when the angle is changed, I cut a dovetailed slot, centered where the screw holes for the miter gauge go into the fence. Then I made some mating dovetail pieces, slid them in the dovetail slot and added screws through the miter gauges into the mating pieces.

With the jig, I can measure the cut angle directly between the fence and the blade and hold angles more accurately. When I need to cut a complementary angle, I simply slide the workpiece along the fence and make a cut on the other side of the blade.

—Joseph M. Santapau, Yardley, Pa.

Methods of Work buys readers' tips, jigs and tricks. Send details, sketches (we'll redraw them) and photos to *Methods of Work*, Fine Woodworking, P. O. Box 5506, Newtown, CT 06470-5506. We will return only those contributions that include an SASE.

Methods of Work

EDITED AND DRAWN BY JIM RICHEY

Clamping boards for planing

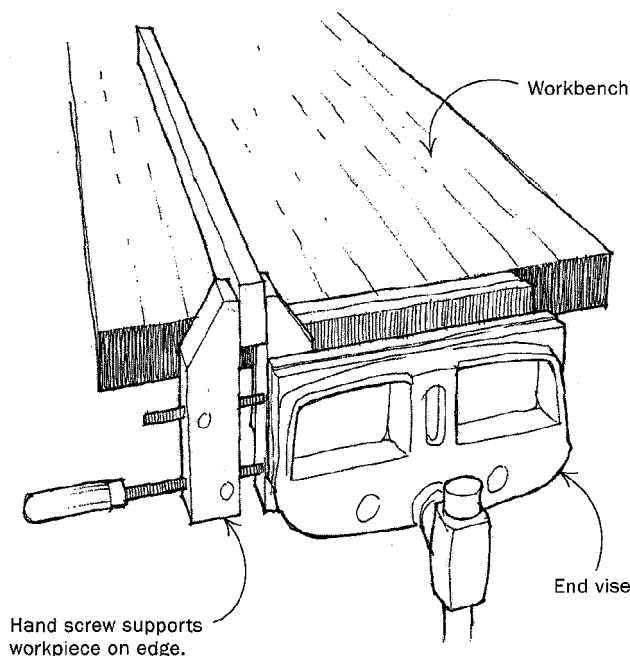

To hold boards on edge on your workbench for handplaning, clamp a small hand screw in the end vise, and tighten the hand screw to the workpiece. This arrangement works well because the benchtop takes all of the downward pressure of planing.

—Anthony Guidice, St. Louis, Mo.

Quick tip: A caning chisel, with its $\frac{1}{8}$ -in. curved blade, will easily remove a stuck biscuit from its groove before the glue sets.

—R. Rix, Washington, D.C.

Turning a straight taper

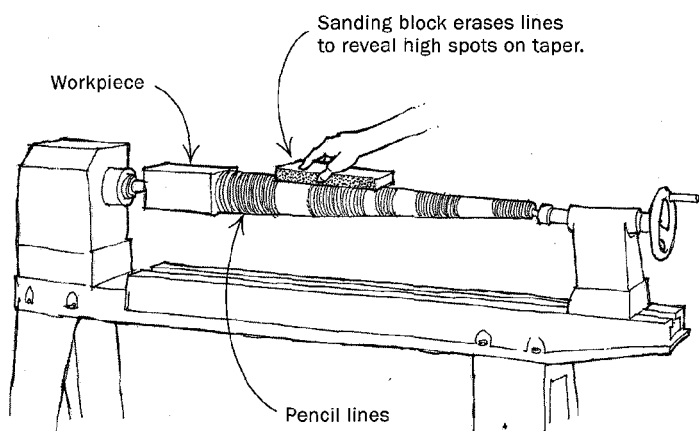

Straight tapers and cylinders are difficult to turn on the first try. To locate the high spots, mark the entire length of the workpiece with a pencil while the piece is turning on the lathe. Then hold a flat

sanding block (with 60- or 80-grit sandpaper glued to the bottom) against the spinning workpiece. The sandpaper will erase the lines on the high points to show you where you need to shave off a little. When the taper is true, the sandpaper will erase all the pencil lines evenly.

Ken Picou, Austin, Texas

Cutting lumber for miniature furniture

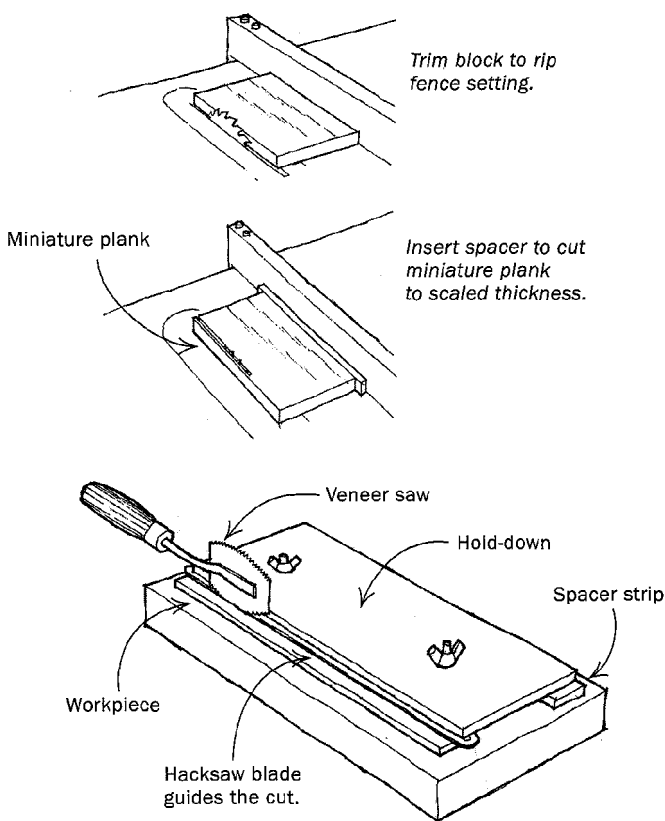

In my shop, I have two simple devices that allow me to cut miniature lumber at the frequently used 1:12 scale. I use the first to slice miniature planks from stock lumber and the second to rip the miniature planks to the desired width.

Select a suitable piece of wood about 12 in. long and 5 in. to 6 in. wide, free from knots and other blemishes. Trim the edges of the block lightly with the saw. For the finish cut, place a spacer strip between the block and the fence. This moves the block over so that the strip removed is of the desired thickness.

I use spacer strips about 12 in. long and as thick as the sawblade plus the thickness of the miniature board. So to cut a miniature board $\frac{1}{12}$ in. thick (a scale thickness of 1 in.), the spacer strip would be $\frac{1}{12}$ in. plus the width of the sawblade. To make a second plank, move the rip fence over, trim the block as before, insert the guide strip and slice another plank.

A piece of standard $\frac{3}{4}$ -in. stock, 12 in. long by 6 in. wide, will make 12 to 15 miniature planks that scale to 12 ft. long, 8 in. wide and 1 in. thick. I have several permanent spacer strips that allow me to cut miniature planks of varying thicknesses.

The second device for ripping the planks to width is a hold-

Methods of Work (continued)

down that uses the smooth edge of a hacksaw blade as a cutting guide. I clamp a plank in the device and run a veneer saw against the straightedge to rip the miniature plank to width. A knife blade tends to follow the grain of the wood and give an uneven cut. The serrated teeth of the veneer saw produce a much better result.

—Don Anderson, Sequim, Wash.

Shopmade horizontal boring jig

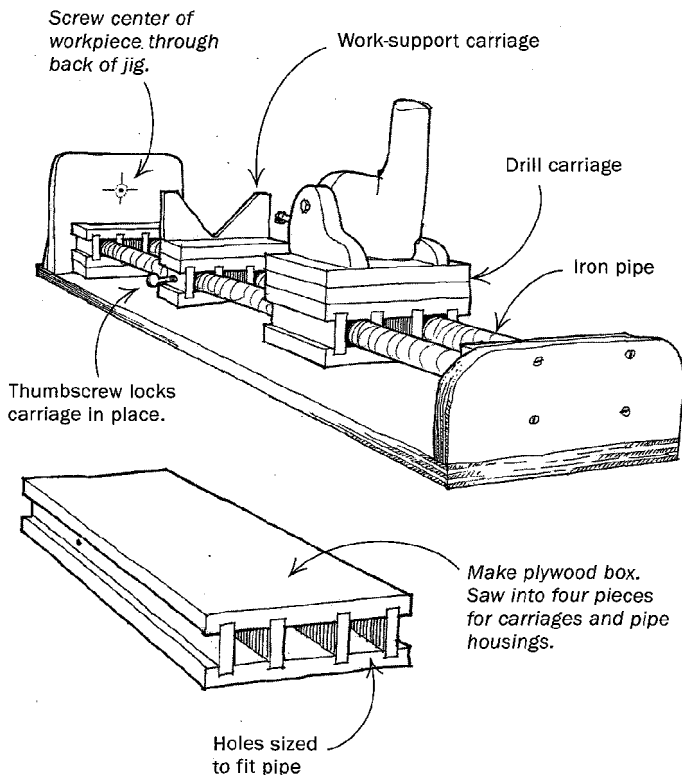

I was faced with the challenge of drilling precisely centered holes along the centerline axis of some turned posts. Because the bed of my lathe wasn't long enough to accommodate the posts, I built a horizontal boring jig using plywood scraps and common iron pipe.

The jig consists of a bed and two carriages, one for the drill and another for supporting the work. First I glued up a hollow plywood box, 16 in. long, with three compartments running the full length. I routed grooves for the vertical walls into the top and bottom of the box. Then I carefully spaced and sized the plywood pieces so that the iron pipe would fit snugly in the openings. Later, I cut this box into four sections to make the two carriages and two pipe housings in the bed.

I wanted to be able to lock the work-support carriage in place to the pipe bed, so I drilled holes and installed T-nuts in the walls of the box before gluing it up. After the glue had cured, I cut the 16-in. box into four sections—two longer sections for the carriages and two shorter sections for the pipe housings in the bed.

I added spacer blocks to the top of the drill carriage to raise up and support the drill. I took advantage of the holes tapped into each side of the drill handle to screw the drill in place on top of the

carriage. By adjusting the drill in place with shims, I was able to get it set to cut holes perfectly centered into one end of the turned posts. I also drilled a small pilot hole through the back of the boring jig for a screw to hold the other end of the workpiece steady.

—C.M. Williams, Newport News, Va.

Quick tip: Much comment has been made about the difficulties of adjusting a plunge router when it is mounted under a router table. The simple solution to this problem is to remove the return springs. These springs are located in the base columns. Removing them is a five-minute job at most. You will be able to raise and lower the router with ease.

—Charles D. Honl, Burnsville, Minn.

Precise cutoffs with a miter saw

Mark lines at 3 in. and 6 in. from sawblade.

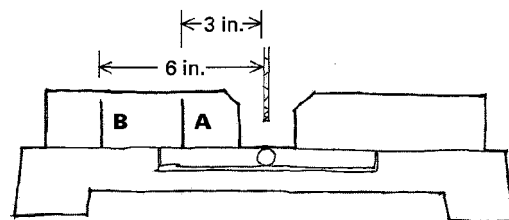

Line up cut line with A, and transfer B to workpiece.

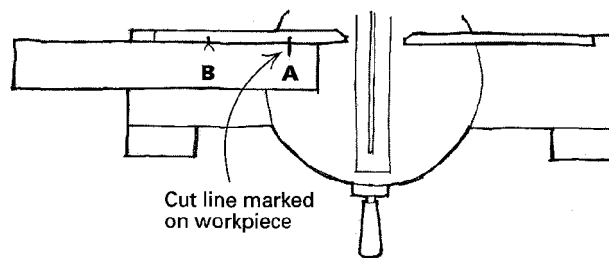

Move transferred line to A, and make the cut.

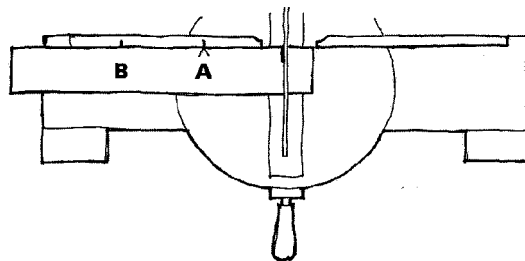

Blade guards on miter saws make it difficult to line up the cut lines marked on a workpiece with the sawblade. I've developed a solution to that problem: Draw a line on the left side of the back fence exactly 3 in. from the blade. Then draw a second line exactly 3 in. to the left of that, or 6 in. from the blade.

To make an exact cut, align the cut line on the workpiece with the first line on the fence. Transfer the second line to the work-

Methods of Work (continued)

piece. Shift the workpiece to the right until the second line on the workpiece lines up with the first line on the fence, and make the cut.

—Dave Basch, Chatsworth, Calif.

Photocopy machine dovetail layout

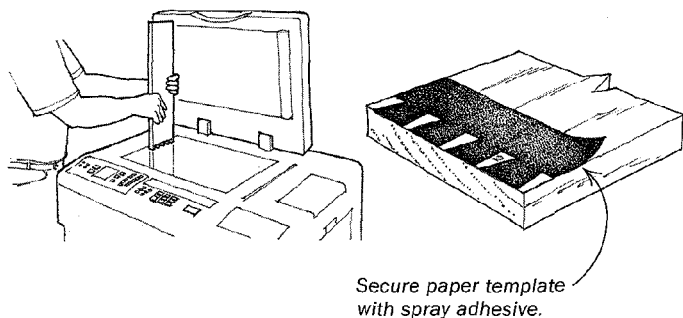

This technique simplifies one of the most awkward and error-prone procedures in making dovetails—marking out tail locations from the pins. First cut the pins. Then, with the pin workpiece standing on end, make a photocopy of it. Be sure to mark it with an identifying number that will reproduce in the copy.

Now glue the photocopied pin pattern to its mating workpiece to give a perfect cutting guide for the tails. Use rubber cement or 3M Spray Mount repositionable artist's adhesive. Aligning the pattern is easy because the photocopy will clearly show the edges and ends of the pins.

You can now either cut directly from the photocopied pattern, or you can use a straightedge and knife to mark through the pattern onto the wood. The result is accurate, tight, perfectly aligned joints every time.

—J.P. Moss, Jamaica, N.Y.

Safety bumpers from tennis balls

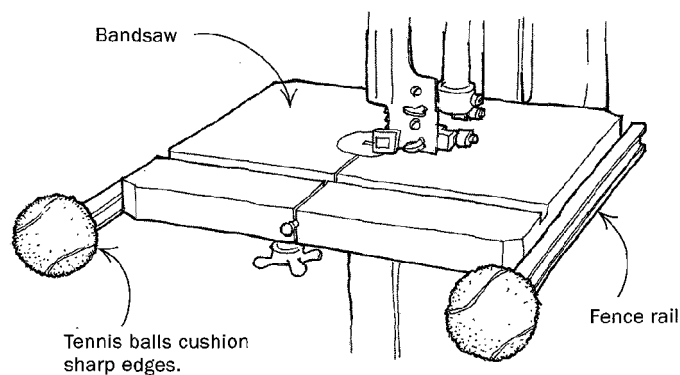

In smaller shops like mine, where space is at a premium, there's the constant danger of bumping into protruding fence rails, like those on my bandsaw. A used tennis ball slipped over the end of a fence rail serves as a bold visual reminder of possible danger and as a cushion against the inevitable bump. Simply cut an X-shaped incision with a hobby knife, and press-fit a ball over the fence rail or similar protruding object.—Robert R. Llewellyn, Memphis, Tenn.

Blemish-free nail holes

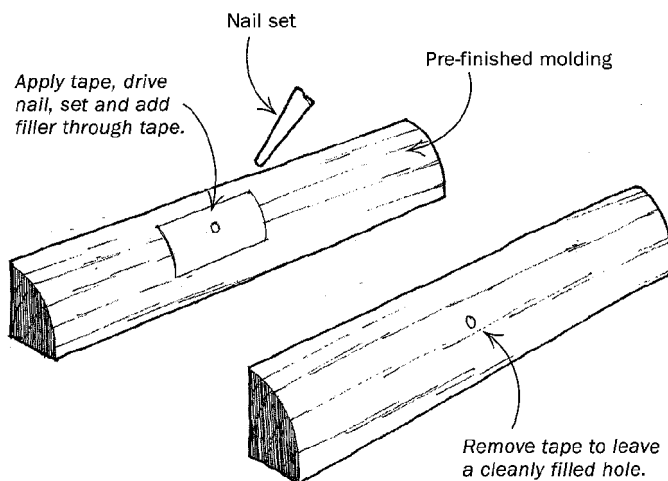

I recently milled some oak molding and before installation stained and finished it to match the existing woodwork. After spending hours to obtain a beautiful finish, I wanted to avoid the inevitable wood-filler smudges that occur when filling the finish-nail holes. So I came up with this simple idea.

Place a short piece of masking tape where you wish to nail. Hammer and set the nail right through the tape. Apply the wood filler over the tape. When you peel away the tape, you have a perfectly filled hole, and the filler does not ruin the finish on the surrounding area.

—James Vasi, Williamsville, N.Y.

Dressmaker's tape is handy in the shop

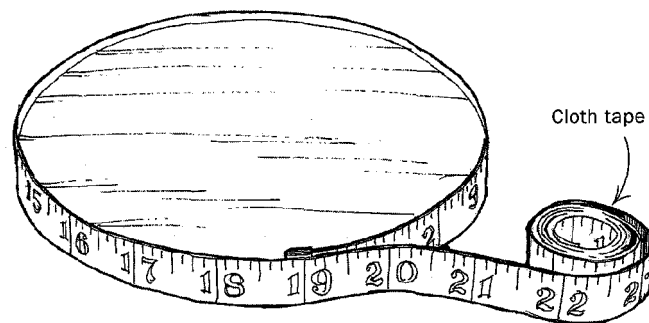

A cloth dressmaker's tape, available from any sewing store (or swiped from a nearby household sewing machine), is a good addition to the woodworking shop. Use it for measuring those curved items that defy a metal tape. When necessary, attach it with masking tape. To find centers, just fold the tape in half.

—Roger Russell, Anderson Island, Wash.

Methods of Work buys readers' tips, jigs and tricks. Send details, sketches (we'll redraw them) and photos to *Methods of Work*, Fine Woodworking, P.O. Box 5506, Newtown, CT 06470-5506. We will return only those contributions that include an SASE.

Methods of Work

EDITED AND DRAWN BY JIM RICHEY

Finishing stands for large doors

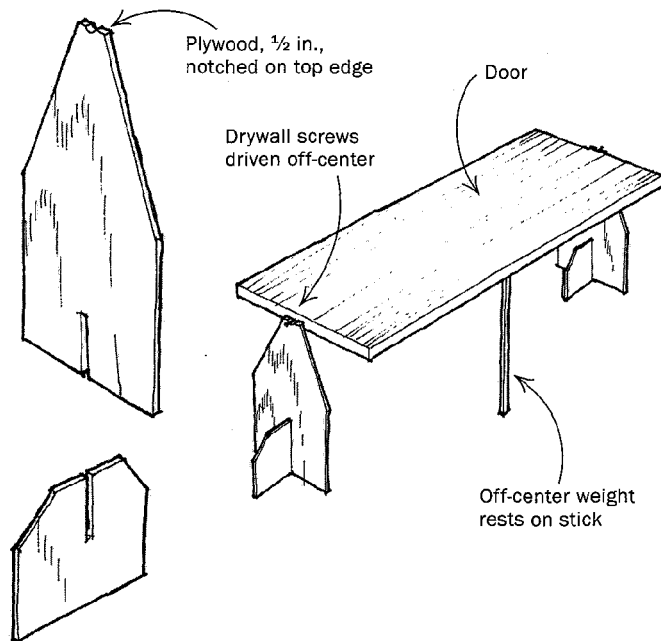

These knockdown stands make it easy to put a finish on doors. Cut the stands from $\frac{1}{2}$ -in. plywood in two pieces that slip together, as shown in the sketch. Drive a 3-in. drywall screw halfway into the top and bottom of the door, 1 in. off the centerline. With the screws as a pivot point, place the door on the stands. Prop up the heavy side with a stick cut to the correct length. The off-center weight of the door will rest on the stick to present an unobstructed horizontal surface ready for finishing. After the finish has set and there's no risk of sag, take the stick out, and swing the door to a vertical position to dry.

—Brad Lewis, Edwardsville, Ill.

Dowel center finder

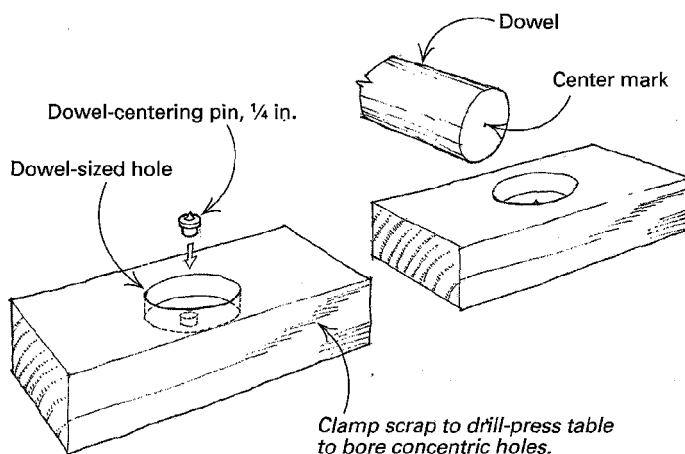

Here's how I made a center finder for dowels that use one of those readily available metal dowel-centering pins.

Clamp a scrap of wood to your drill-press table. Drill a hole the same size as the diameter of the dowel, $\frac{3}{8}$ in. deep, using a Forstner bit. Without unclamping the wood, remove the Forstner bit, substitute a $\frac{1}{4}$ -in. brad-point bit, and drill a hole in the center of the original hole about $\frac{5}{16}$ in. deep.

Insert a $\frac{1}{4}$ -in., metal dowel-centering pin in the center hole. Make sure it is seated securely. Place the dowel in the hole, and press down firmly. The indentation left by the point of the centering pin should be exactly in the center of the dowel.

Because the flange diameter on the $\frac{1}{4}$ -in. metal pin is $\frac{3}{8}$ in., you're limited to finding the center of dowels larger than that.

—John Saggio, Little Neck, N.Y.

Radiused corners on countertops

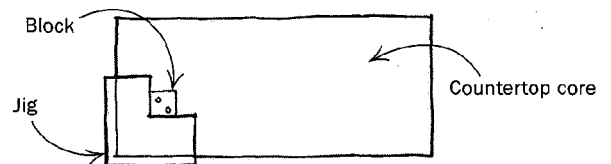
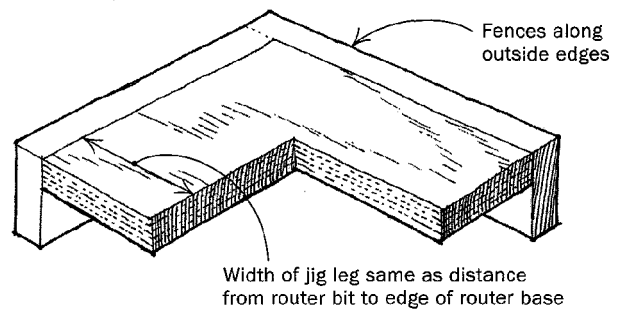

1. Position block with jig and fastener.

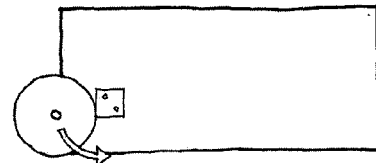

2. Pivot router against block, making light plunge cuts.



3. Finished countertop is ready to laminate, after removing block.

I like to put a radiused corner on any countertop that projects into a traffic area: The corner won't hurt as much when you bump into it. This simple jig, used with a scrap block and a plunge router with a round base, helps me cut the corner quickly and accurately. For plastic laminate counters, I cut the corners of the core before applying the laminate.

Measure the distance from the edge of your router base to the cutting edge of a straight bit placed in the chuck. Cut an L-shaped

Methods of Work (continued)

piece of plywood with each leg the same width as the bit-to-base distance. Attach fences to the long sides of the jig so that it will butt square against the corner of the countertop.

With the jig held in place on the corner, nail or screw a scrap block to the countertop core. Remove the jig, and make light cuts with the router against the block, plunging $\frac{1}{4}$ in. at a time to cut the radius.
—John Bousfield, Cocoa, Fla.

Driver for eyescrews

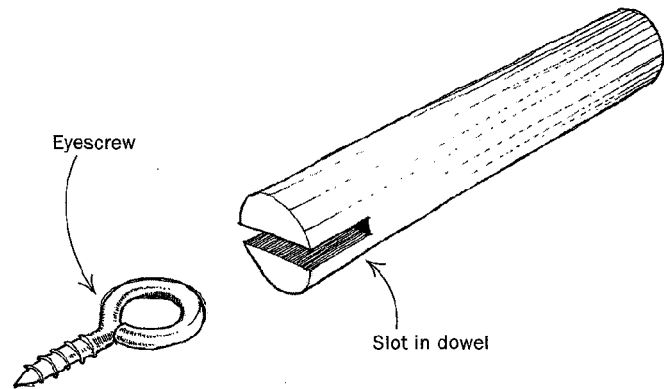

Installing hook screws or eyescrews is hard on finger and thumb, especially if you have a lot of them. It takes just a few seconds to make this little tool that acts like a screwdriver. Simply cut a slot in one end of an appropriately sized dowel.

—Yue Ma, Burnaby, B.C., Canada

PVC vacuum system tips

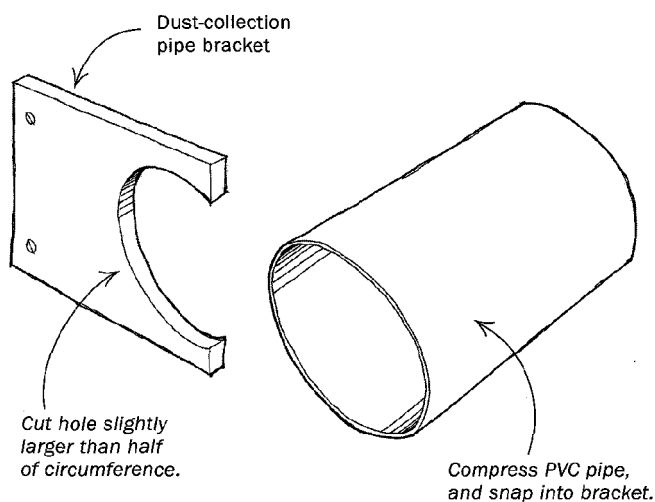

These brackets are quick and easy to make and work especially well with a dust-collection system made of thin-wall PVC pipe. If the system becomes clogged, the brackets allow pipes to be removed, cleaned and snapped into place in seconds.

To make a bracket, trace the pipe's perimeter, and cut out one end of a bracket board so just over half the pipe's circumference is held by the cutout. Attach brackets to the wall or to ceiling joists.

Compress the flexible pipe as you snap it into each bracket.

To ground a PVC pipe system, run metal furnace tape along the length of the outsides of the pipes. Fold the tape inside the elbow joints so that it contacts the tape on the straight lengths.

—Peter Sieting, Bath, NY.

Quick tip: Pieces of used pressure-sensitive sandpaper can be stuck on jigs and clamps to provide a non-stick surface. For example, a small piece of pressure-sensitive sandpaper applied to the jaws of wooden hand screws will help stop the workpiece from slipping when clamping pressure is applied.

—Joseph C. Deneffeld, San Francisco, Calif.

Clamping pads for bar clamps

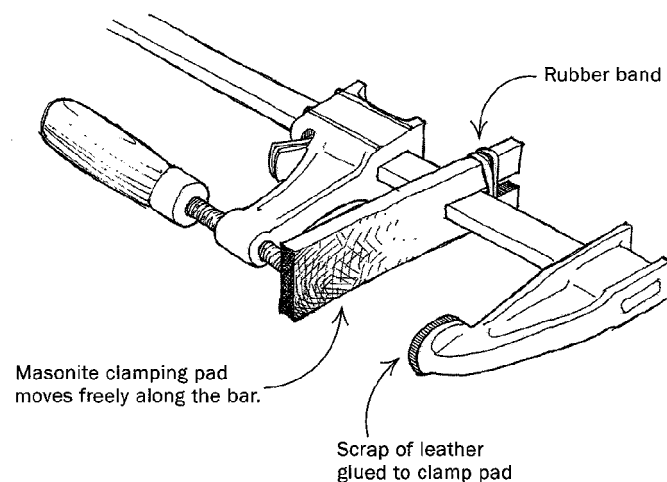

I don't have a third hand to hold a non-marring pad under the screw of my bar clamp. So I cut a slot in a scrap piece of Masonite and attached it loosely to the clamp bar with a rubber band. To pad the other end, I glued a piece of shoe leather to the clamp jaw.

—Ted Tedeschi, Prescott Valley, Ariz.

Disposable swab

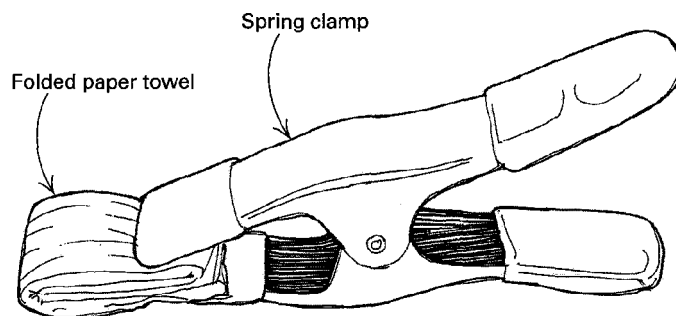

When applying a small amount of stain or finish, I make a swab by tightly folding a piece of cloth or paper towel into a pad. I then lock the pad into a small Vise-Grip or a spring clamp, so I can

Methods of Work (continued)

hold it during use. When I'm finished applying the stain, I just throw away the pad. —Omar V. Showalter, Harrisonburg, Va.

A jig to set accurate saw angles

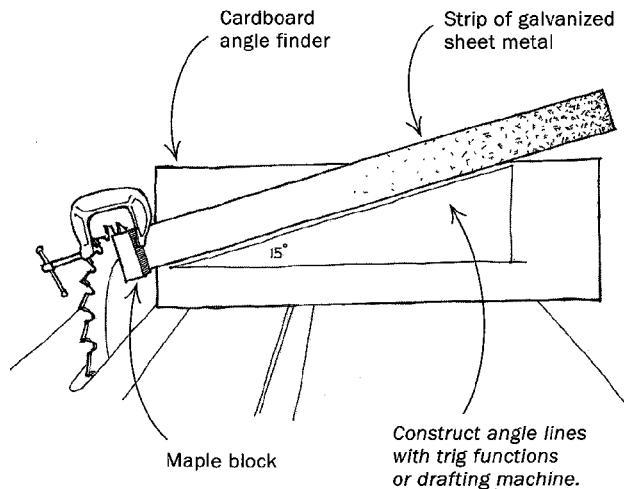

When I wanted to make a segmented cylinder on my tablesaw, I discovered the importance of setting the blade at the exact tilt angle. But the tilt scales provided on the saw are imprecise at

best. So I developed this technique that—if carefully done—will produce a blade-tilt angle accurate to within one one-hundredth of a degree.

The key to this technique is a flat, parallel strip of 22-gauge, galvanized sheet metal, about 1 in. or so wide and 10 in. long. Add epoxy, and screw the strip to a 1/2-in.-sq., 1-in.-long block of hard maple. The accuracy of the final sawblade setting is directly proportional to how square the wood block is to the edge of the metal strip, so take care when fastening them together.

To use this device, crank up the blade partway, and then clamp it onto the blade with a small C-clamp. Be sure to clamp the wooden part to a flat, clean area of the blade, avoiding any carbide teeth that are thicker. The metal strip serves as an indicator: The angle at which it is inclined is an accurate gauge of the tilt angle of the blade.

For each desired angle setting, make up an angle finder from a piece of cardboard. Scribe the desired angle on the cardboard using a drafting machine, or construct the angle using trigonometric functions and a calculator. Place the cardboard finder behind the gauge, and then tilt the blade until the angle matches the line on the finder. —Helmut Wolf, Albuquerque, N.M.

Methods of Work buys readers' tips, jigs and tricks. Send details, sketches (we'll redraw them) and photos to Methods of Work, Fine Woodworking, P.O. Box 5506, Newtown, CT 06470-5506. We will return only those contributions that include an SASE.

Methods of Work

EDITED AND DRAWN BY JIM RICHEY

Handplaning a convex surface

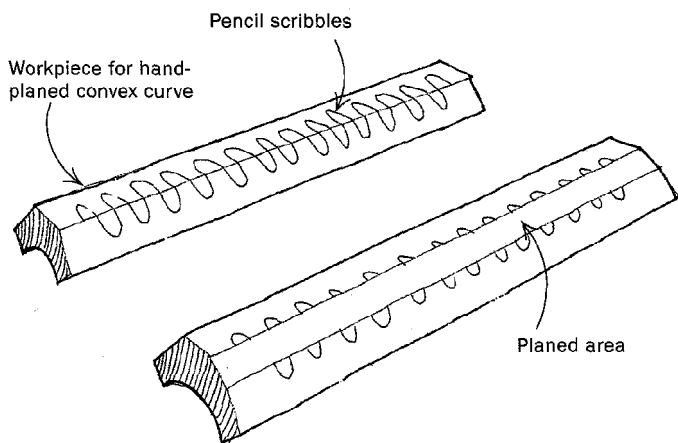

Handplaning a consistent convex shape is tricky. Here's a technique I discovered when I was shaping a crest rail. Starting with a beveled workpiece straight from the tablesaw, I began by planing off the apex of the bevel the length of the boards. I quickly realized that it was going to be tough to keep my plane at the proper angle for the entire length of the board and to keep the curve consistent.

So I squiggled some pencil lines back and forth across the bevels the whole length of the workpiece. By planing through the lines, I could quickly gauge how much material I was removing and hold the plane at the correct angle.

—Val Nelson, Everett, Wash.

Improved tablesaw tapering jig

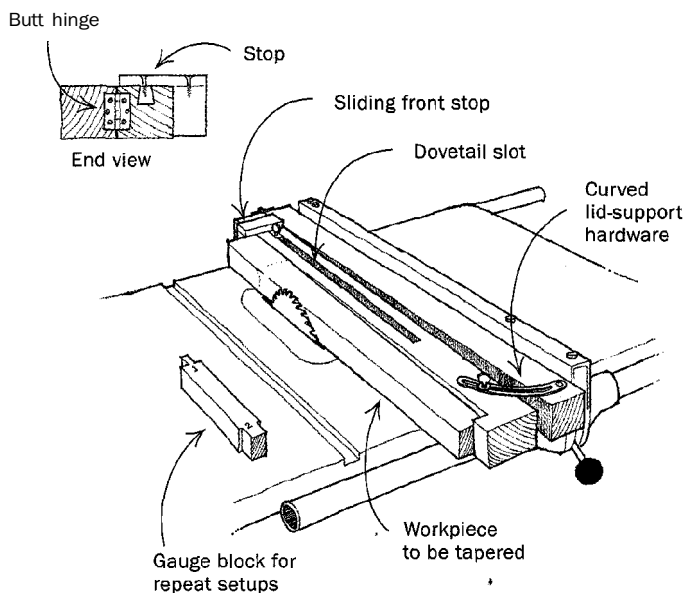

You don't need a dedicated tapering jig to accurately set up often-repeated production runs. With this adjustable jig and a dedicated gauge block, you can repeat an exact setup time and again.

Construction of the jig is straightforward. Size the two arms so

they are 3 in. longer and 1/2 in. thicker than the longest and thickest leg you intend to taper. Fasten the two arms together at the top end with a butt hinge. Install a curved lid support on the bottom end to allow the outboard arm to swivel and to be locked in place at the chosen taper angle. Cut a dovetail slot in the outboard arm, and install a sliding front stop, as shown in the sketch. The adjustable front stop ensures that a snug fit is achieved for any length.

To repeat a given setup, you will need a gauge block. The gauge block contains three critical measurements: the rip-fence to blade setting, the initial taper angle and the second taper angle. To use the gauge block, first determine the rip-fence setting using the block's length. Then, to set the initial taper angle, insert the no. 1 end of the gauge block in the gap between the two arms at the bottom end of the jig. Lock the arm at that initial setting, and cut two sides of the taper on all legs. Next insert the no. 2 end of the gauge block in the gap, adjust the jig to the second angle, tighten it in place and make the third and fourth taper cuts on all legs. To finish the legs, clean up the cuts with a jointer or handplane.

—Eric Orcutt, Tallahassee, Fla.

Quick tip: To keep glue from freezing in a cold shop, place a 15-watt light bulb in an old fishing cooler, and store the glue in there.

—James L. Miller, Frederick, Md.

Clamping pedestal table legs

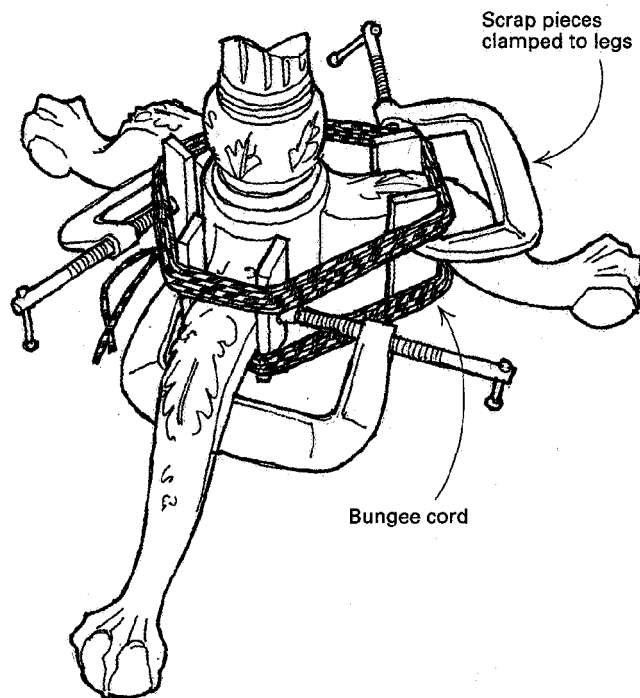

Clamping the dovetailed legs of a pedestal table during glue-up is not easy. There is no place to put the clamps. On the first table I made, which was designed by Franklin Gottshall, I left a square protrusion on the knee of the leg, per his suggestion, to provide a clamping perch. But the protrusion had to be removed later, leav-

Methods of Work (continued)

ing an awkward spot to be carved and shaped. Wiser the second time around, I used clamped scraps and a bungee cord, as shown in the sketch. It worked perfectly, and it allowed me to finish carving the legs before gluing up the table.

—*Dr. Thomas M. Wheeler, Montgomery, Ala.*

Handrail push block

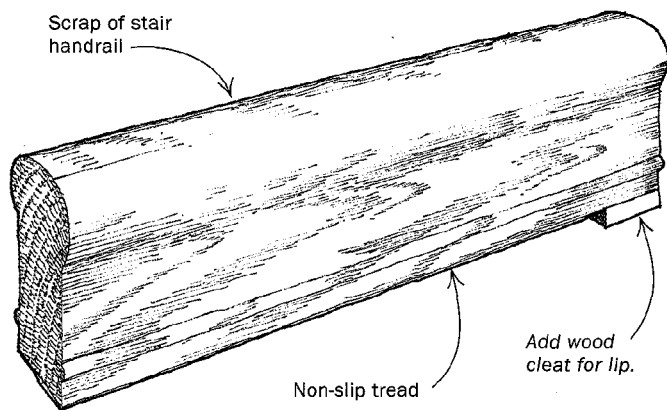

When I had a nice piece of oak handrail left over from a stair project, I used it to make a push block for my jointer. I stuck some self-adhesive, non-slip tread to the bottom of the handrail and glued a small lip to the back to hold a workpiece firmly in place. The push block is solid, ergonomically correct and, at 4 in., tall enough to prevent even long fingers from extending into the danger zone.

—*Mike Vincent, Littleton, Colo.*

Cutting stretchers for tapered legs

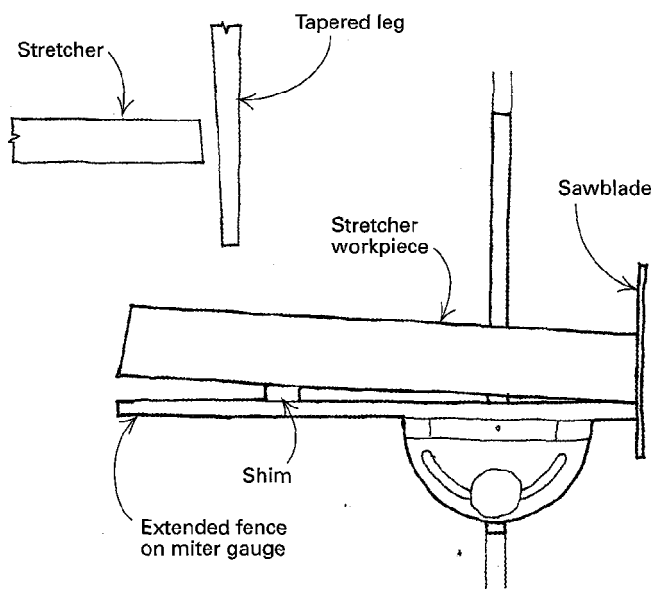

The ends of stretchers that join to tapered table legs must be cross-cut at the same angle to join the legs properly. You can calculate the angle and set the tablesaw miter gauge to the calculated angle.

But there is an easier and more accurate method—similar to the way carpenters cut roof rafters.

Characterize the taper as x in. of taper over y in. of length. When you characterize the taper in this way, it's easy to set the proper angle by leaving the miter gauge set at 90° and shimming the stretcher out from the miter gauge to get the correct angle.

For example, if the leg tapers $\frac{1}{4}$ in. over each 12 in. of length, place a $\frac{1}{4}$ -in. shim 12 in. from the sawblade to set the correct angle of the stretcher cut. Cut one end of the stretcher; then flip it over, and cut the other end to the desired length. If necessary, you can use a smaller shim closer to the blade if you maintain the same x to y ratio. In the example cited, a $\frac{1}{8}$ -in. shim 6 in. from the blade would accomplish the same result.—*James Potzick, Potomac, Md.*

Mobile tool base

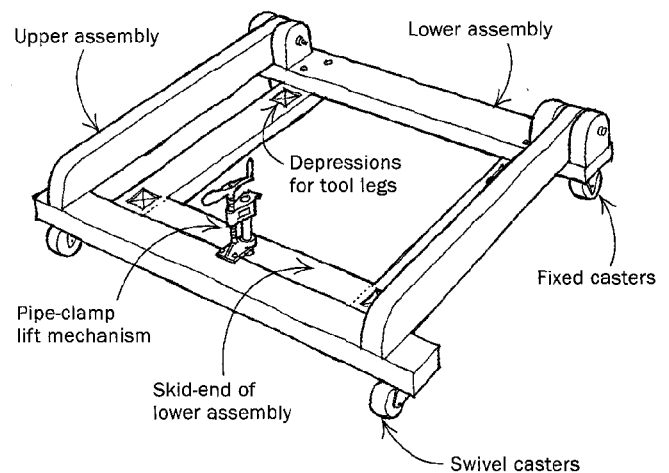

Raise upper assembly to make tool stationary.

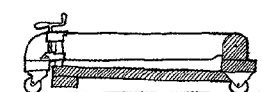

Lower upper assembly to make tool mobile.

If, like me, you have collected more large stationary tools than you have room to store, this mobile base will enable you to move heavy equipment around your shop.

The base consists of two assemblies, an upper and a lower. The lower assembly has fixed casters at the rear and a wood skid at the front. Tool legs sit in depressions cut in the lower assembly. As long as the skid is on the floor, the weight of the tool keeps the assembly from moving. When the skid is lifted from the floor by the pipe-clamp lifting mechanism, weight is shifted to swivel casters on the upper assembly, and the base is free to roll.

Construction of the wooden parts is simple. All pieces are cut from standard 2x4s, except the back part of the lower assembly, which is ripped from a 2x6. For the lifting mechanism, use the screw end of a Pony No. 50 pipe clamp with a $7\frac{1}{2}$ in. length of $\frac{3}{4}$ -in. pipe. Drill two holes through the face of the clamp, and install wood screws to hold it to the upper assembly. Drill a hole into the skid for the pipe, and position it in the lower assembly so that the wheels on the upper assembly just touch the ground when

Methods of Work (continued)

the clamp screw is at its midpoint of travel. Drill a $\frac{5}{16}$ -in. hole through the pipe, and pin it into the lower assembly with a $\frac{1}{4}$ -in. lag screw. Tightening the clamp raises the skid-end of the lower assembly, allowing the mobile base to roll.

—Jeffrey D. Anderson, Melbourne, Fla.

Drawing a curve with a spline

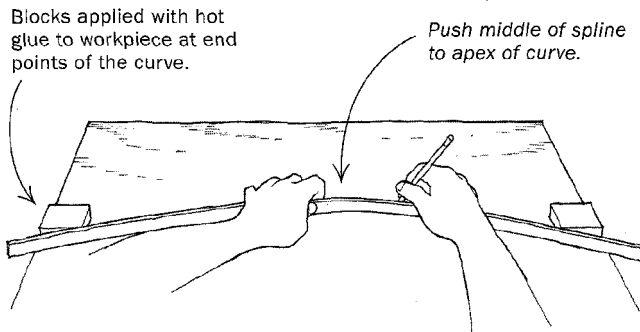

Drawing a curve with a thin wooden spline is an awkward task for one person to do. You really need one pair of hands to hold the spline steady and another pair to draw the curve. Here's how to draw a curve without having to search for a helper.

Rip a $\frac{3}{32}$ -in.-thick spline from $\frac{3}{4}$ -in., knot-free stock, about 6 in.

longer than the curve you want to draw. Mark the centerline on the spline. Make two stop blocks out of scrap stock. Mark the two end points and the middle apex point of the desired curve on the workpiece, and attach the two stop blocks at the end points with hot-melt glue. With one hand, place the spline against the two blocks, and push it up, aligning the center mark with the apex mark on the workpiece. Draw the curve with the other hand.

—John Saggio, Little Neck, NY.

Disposable benchtops

Every shop needs more benchtop work space from time to time. And gluing and painting operations are best done on a surface where drips or spills won't mar the permanent top. I use several portable work surfaces that I made by gluing two pieces of corrugated cardboard together—with their corrugations at right angles—to increase rigidity. These panels are lightweight, easy to handle, easy to store and inexpensive.

Once a workpiece has been glued or painted, I leave it on the portable pad and move it to a safe area until the glue is set or the paint has dried.

—Don Anderson, Sequim, Wash.

Methods of Work buys readers' tips, jigs and tricks. Send details, sketches (we'll redraw them) and photos to *Methods of Work*, Fine Woodworking, P.O. Box 5506, Newtown, CT06470-5506. We will return only those contributions that include an SASE.

Methods of Work

EDITED AND DRAWN BY JIM RICHEY

Miter fixture for cutting moldings

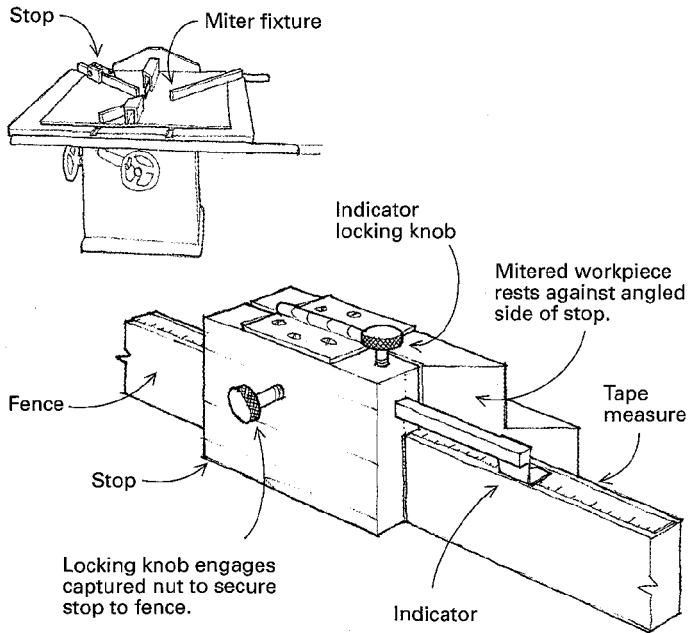

This tablesaw miter fixture has an adjustable stop to cut picture frames and other moldings simply and quickly. The fixture itself is fairly standard with rails on the bottom that run in the miter-gauge slots, fences set at 45° angles and blade guards. The stop has an adjustable indicator that runs through the body of the stop. With the indicator, I can adjust the length of the cut to account for the width of the frame pieces plus clearance for the glass. Once this extra length (for any given frame material) is set into the indicator, I slide the stop along the fence and clamp when the indicator points to the actual size of the artwork. A tape measure on the fence makes it easy to read dimensions.

—James R. Thomson, West Vancouver, B.C., Canada

Smoothing tool

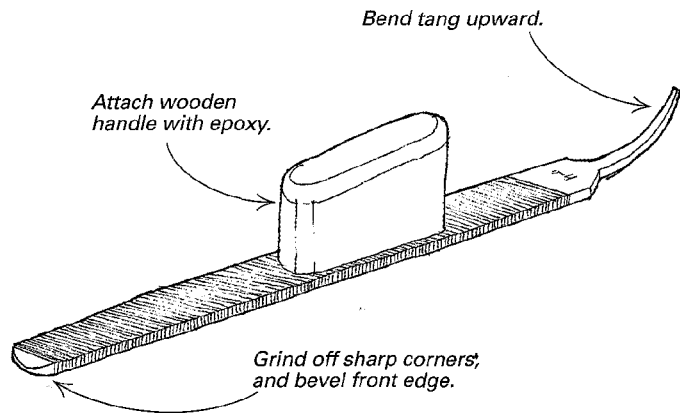

A flat file is a good tool to smooth a wooden plug or an errant nail tip that projects from the flat surface of a woodworking project.

But a file is often awkward to use in this situation, and the sharp corners scratch. So I modified a file for this application by bending the tang upward, rounding off the sharp corners and gluing, with epoxy, a small wooden handle to the top of the file. It works great.

—Howard E. Moody, Upper Jay, N.Y.

Quick tip: Floral designer's foam, that green stuff they stick flowers in, makes a great storage system for router bits. Simply cut a block whatever size you want and press the shafts of the bits into the block. The holes are clean, and this material seems to prevent rust on the shafts of the bits.

—Jeffrey N. Sales, Tucson, Ariz.

Shoulder block for hand-cut dovetails

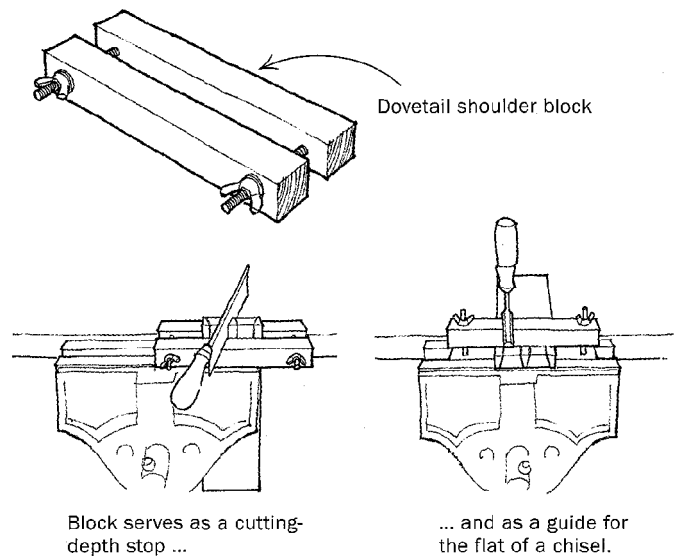

This simple little shoulder block is not my idea, but I've adopted it and now have several different sizes for different situations. To make the block, start with two 1¼-in.-sq. sticks of hardwood, about 4 in. longer than the widest dovetail you normally cut. Drill through the ends and install carriage bolts and wing nuts, as shown in the sketch above.

To use the block after you've marked out the pins, carefully tighten the block on the workpiece at the base of the pins. The shoulder block serves two purposes: as a cutting-depth stop and as a chisel guide for removing the waste.

With the block in place, simply saw the pins until the blade touches the block. After sawing, clamp the block and workpiece in a wood-faced vise, lay the chisel's flat side against the block and begin tapping away the waste. The block will guide the chisel up to the line. This shoulder block is also useful for paring the shoulders of tenons and cleaning up through-mortises.

—Len Crane, Basin View, N.S.W., Australia

Quick tip: To embellish one of your wooden creations with a name, initials or numbers, use dry-transfer lettering sheets, commonly available at art supply stores. Simply place the transfer sheet on the workpiece and rub the back of the sheet to transfer the letter. The method I prefer is to seal the wood with a coat

Methods of Work (continued)

of varnish, apply the letters, then add another coat of varnish to protect them. —*H. Norman Capen, Granada Hills, Calif.*

Folding sawhorse

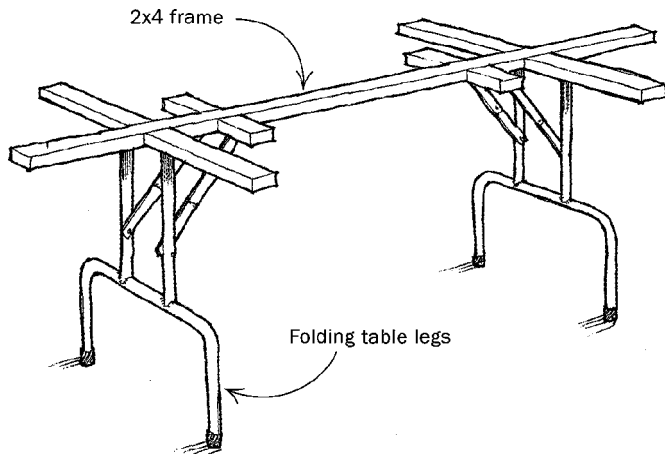

Conventional sawhorses never seemed to fit my needs. So I made a skeleton table frame from 2x4 stock and attached metal folding legs, offsetting each pair so that they would both fold up flat for storage and transport. This table frame will support an entire sheet of plywood. And in a pinch, you can use plywood to turn this set-up into a worktable. —*James E. Taylor, Brevard, N.C.*

Removing dovetail waste with a router

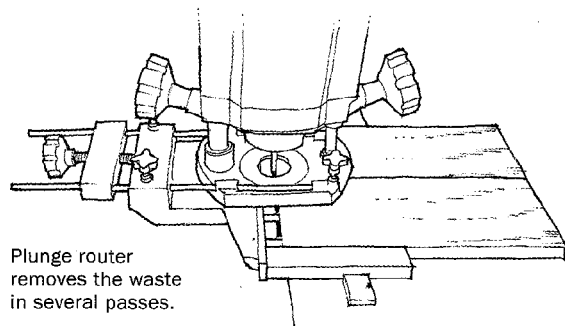
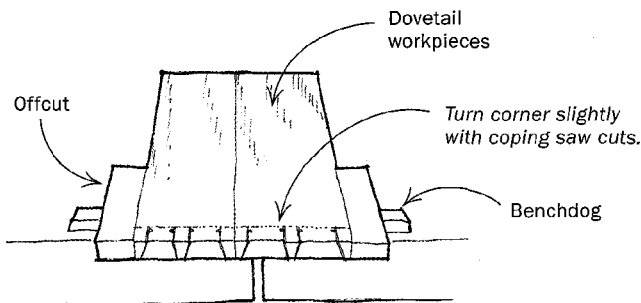

Using a chisel to chop out the waste between dovetail pins and tails is both tedious and time-consuming. So I speed up the operation by using a router fitted with a fence and a small-diameter

bit. This technique works especially well with large dovetails.

To use this technique, lay out and cut the pins first. With a coping saw, turn the corner slightly at the bottom edge of the waste piece. This will allow the waste to drop out cleanly when routing. On the edge of the bench, sandwich two workpieces between two offcuts of the same thickness and clamp them all together with benchdogs. Orient the workpieces so that the widest part of the pin is up; otherwise, you'll cut off part of the pin as you plunge through with the router.

Set up a small plunge router with a fence so that the bit cuts exactly on the line. Plunge through the waste starting as near to the dovetail sawcuts as you dare. Do this in as many steps as required, nibbling away a small amount at a time. To complete the joint, chop out the corners left by the router with a wide chisel, guiding the chisel on the flat areas removed by the router.

—*Richard Jones, Houston, Texas*

Quick tip: An X-Acto hobby knife, the one with the larger, red plastic handle, makes a perfect marking knife. Blades are replaceable and held rigidly in the chuck. The knife is inexpensive and can mark light or heavy lines. —*Anthony Guidice, St. Louis, Mo.*

Fence-setting gauge block

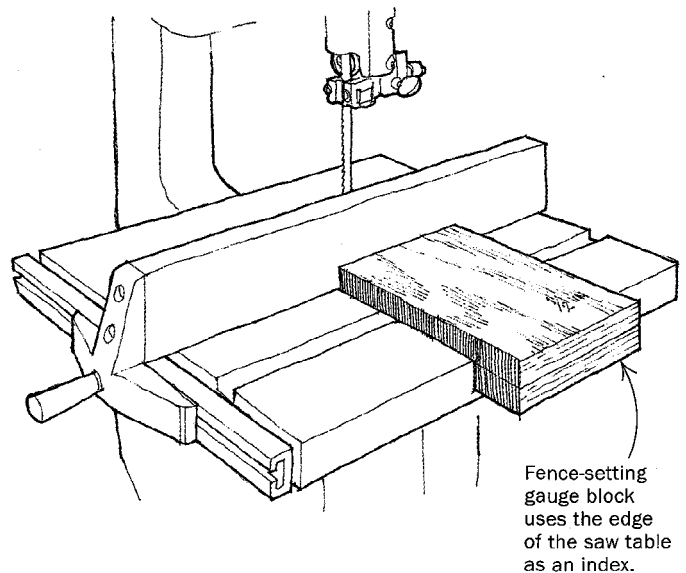

When I found myself setting the bandsaw fence to the same resaw setting again and again, I figured there must be a better way. Now I avoid the time-wasting exercise of measuring from the blade to the fence, starting the first cut, shutting off the saw to check my measurement, adjusting the fence, taking another test cut, and so on. I use simple gauge blocks made from scraps of $\frac{3}{4}$ -in. plywood.

To make a gauge block, set and lock your fence exactly where you want it. Cut and clamp two plywood strips, 2 in. wide, so that the top strip butts against the fence, and the bottom strip hooks the edge of the saw table. Glue and screw the pieces together. Mark the measurement you're using on the gauge block, and you'll be able to return to the same size cut every time, with ease. Also, you can use this same concept on your tablesaw by modifying the de-

Methods of Work (continued)

sign slightly so that the gauge block pops right into one of the miter-gauge slots.
—Bob Gleason, Hilo, Hawaii

Sharpening jig for a stationary belt sander

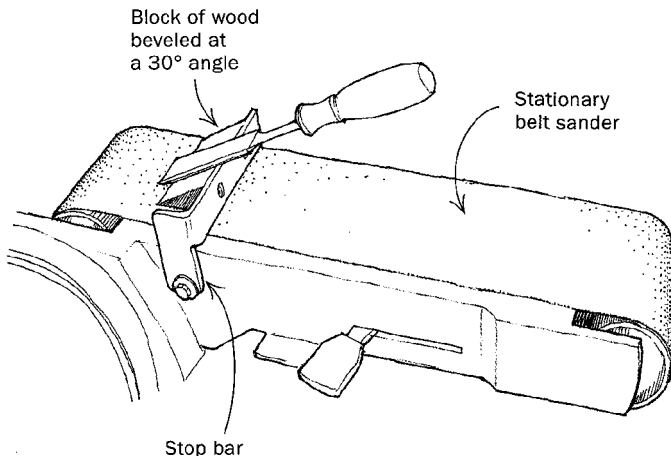

To sharpen chisels and other tools, I screwed a small 30° block of wood to the back side of the stop bar of my stationary belt sander. I use a 220-grit belt and make sure the back of the tool is flat against the block when I press the blade against the moving belt. The longer belt on the stationary machine helps prevent overheating and softening the edge of the tool.

Because I grind most of my tools at 30°, I usually leave the block at that setting (it does not interfere with the normal use of the sander). But if I need a different setting, I can loosen the stop-bar attachment and pivot the block to any angle between 25° and 40°. One thing to remember: If you have a dust collector connected to your sander, disconnect it when sharpening tools. The sparks could start a fire.

—Bob Kelland, St. John's, Newfoundland, Canada

Vise for clamping miters

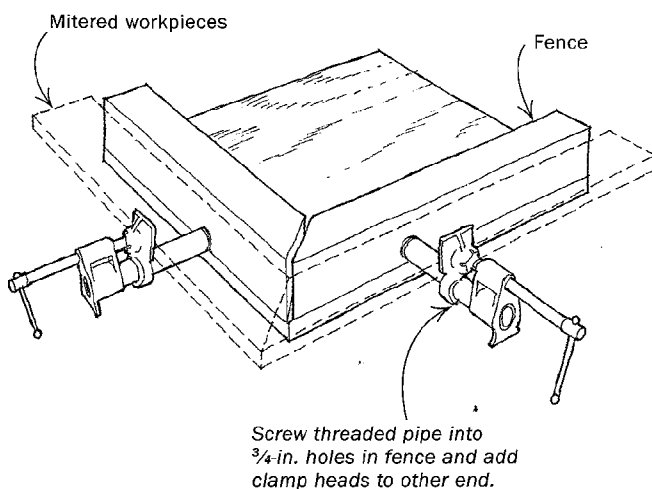

Faced with the need for clamping up miters in large stock, I made this miter vise with a piece of Baltic-birch plywood, a couple of

blocks of hard maple and two pipe-clamp heads. To make the fixture, drill 3/4-in. holes through the maple blocks. Miter the ends of the blocks and glue and screw them to the plywood base. Make sure they are square to each other and leave a slight gap between them at the miter. Thread 3/4-in. black pipe into the holes. (There's no need to tap the wood first because the threads on the pipe will cut female threads into the maple. A pipe wrench and wax will help with this step.) The length of pipe you choose can vary according to the width of the stock you will be clamping. I used 5-in.-long pieces. Screw the pipe-clamp heads onto the protruding pieces of pipe to complete the vise.

—Eric Derry, St. Louis, Mo.

Quick tip: The mildly abrasive nature of baking soda can be useful in the shop. Mix the soda with water to form a thick paste that will clean router bits, sawblades and saw tables. Scrub the item with the paste, wipe away the residue and then dry and buff.

—R.B. Himes, Vienna, Ohio

Movable bench lighting

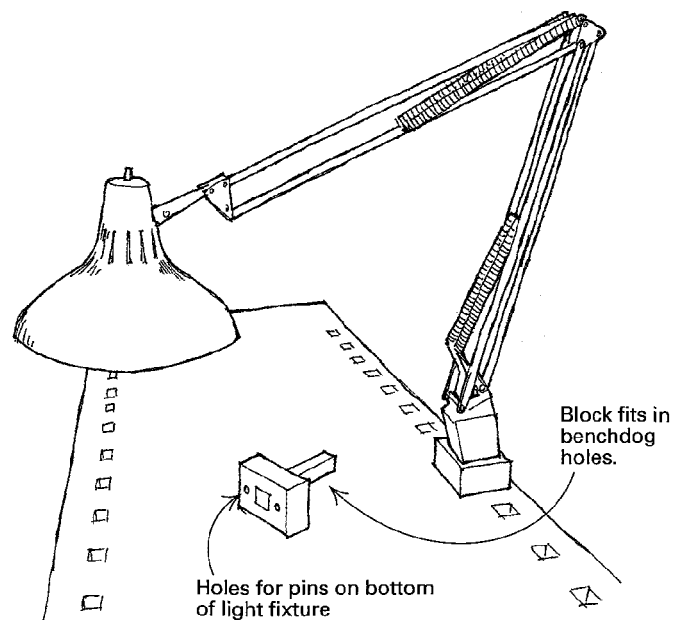

Because my workshop has little natural light, I needed a versatile system for concentrating strong light where it was needed for executing very detailed wood carving. I cut a thick hardwood block with a benchdog-sized pin protruding from the bottom. Holes in the block accept the mounting pins in my lamp. I can move the block anywhere along the row of benchdog holes on either side of my carver's bench to put the lamp and the light right where they are needed.
—Frederick Wilbur, Lovingson, Va.

Methods of Work buys readers' tips, jigs and tricks. Send details, sketches (we'll redraw them) and photos to *Methods of Work*, Fine Woodworking, P.O. Box 5506, Newtown, CT 06470-5506. We will return only those contributions that include an SASE.

Methods of Work

EDITED AND DRAWN BY JIM RICHEY

Mounting panels with keyhole slots

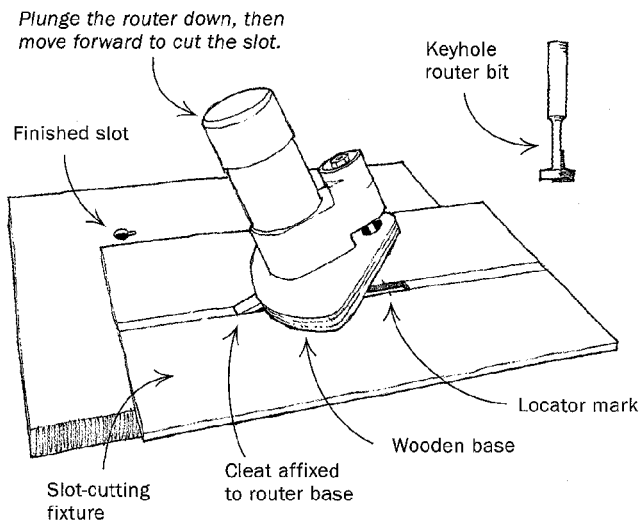

A keyhole router bit cuts a T-shaped slot that is useful for hanging picture frames. However, with a couple of simple fixtures, you can also use this bit to mount large panels flat to the wall. The benefits are many: The slots allow solid wood panels to expand and contract; a damaged panel can easily be taken down, repaired and re-installed; and finally, there's no visible means of attachment, such as wires or nail holes.

To mount a panel with keyhole slots, you'll need a slot-cutting fixture and an alignment template. The alignment template is simply a piece of hardboard or plywood drilled with a pattern for mounting the screws. Attach the template to the wall, drill holes in the wall and insert pan-head screws, tightening them against a 1/4-in.-thick scrap of wood to leave a consistent gap between the screw head and the wall. Transfer the template to the back of the panel and mark each screw location.

To make the slot-cutting fixture, glue up several pieces of 1/4-in.-thick material, leaving a 3/4-in.-wide, 6-in.-long slot in the middle of the fixture (as shown in the sketch). To ride in that slot, make a 3/4-in.-wide, 5 1/2-in.-long maple cleat, drill a hole through one end of the cleat, then screw the cleat onto the bottom of your router base with the hole centered over the bit. (A wooden base added to your router makes this easier.) It is important that about 1 in. of the cleat hang over the edge of the router base to provide a lever arm for plunging the router. The cleat should slide freely in the slot.

Place the fixture on the back of the panel, aligning it with the

A new reward for your best tips

Beginning with our next issue (April 1999), *Fine Woodworking* will present an engraved Lie-Nielsen plane to the author of the featured tip in each issue's *Methods of Work*. We will continue to pay for the other tips, jigs and tricks published in *Methods of Work*. Send details, sketches (we'll redraw them) and photos to *Methods of Work*, *Fine Woodworking*, P.O. Box 5506, Newtown, CT 06470-5506. We will return only those contributions that include a SASE.

screw-location marks, and clamp the fixture in place while you make your plunge cuts. You may need to adjust the depth of the screw heads on the wall for a perfect fit.

—Tom Griffin, Pleasanton, Calif.

Workbench anvil

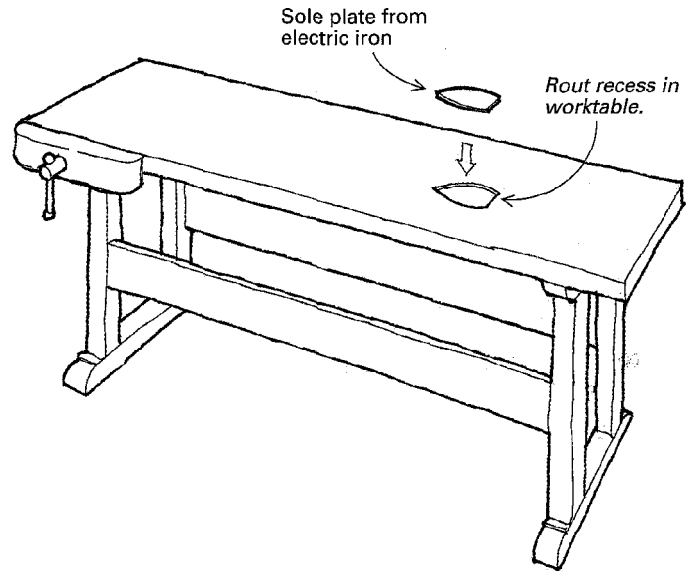

One of the things missing in my workshop was a hard surface to hammer against. I solved this problem by routing out the top of my workbench and inlaying the sole plate of an old electric iron. An 8-in. square of 3/8 in. steel plate would work just as well. If possible, locate the inlay over a structural member.

—Bruce Revell, Magill, South Australia

Split-free nail removal

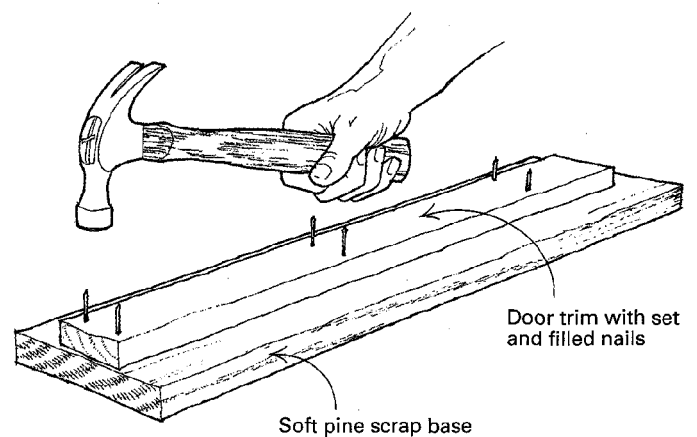

When removing nails from window and door trim that will be reused, the heads invariably splinter the face of the trim when the nail is backed out. To avoid this, place the trim upside down on a

Methods of Work (continued)

soft pine scrap, and drive the nail heads into the pine. The pine supports the wood around the head and reduces splintering.
—Tom Quinn, Auburn, N.Y.

Marking dovetail pins

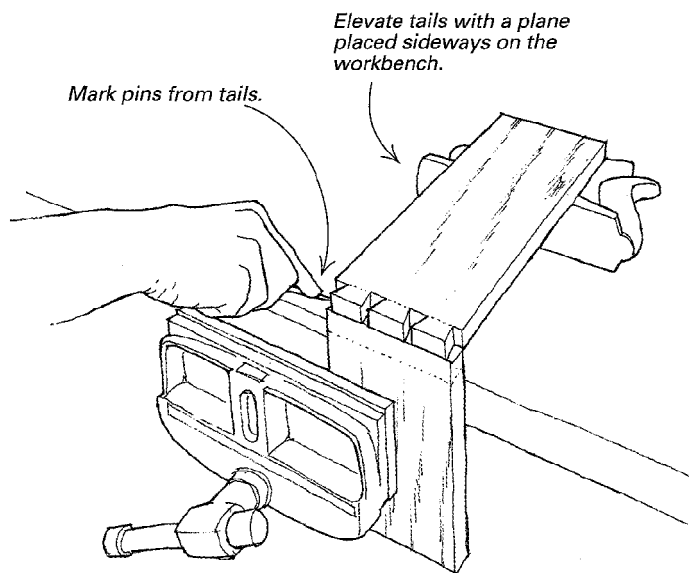

Here's a trick that simplifies the critical step of marking dovetails. Cut the tails in the drawer side first. Lay a handplane on its side on the bench, and damp the drawer front (on which the pins will be marked) in the vise to the height of the plane. It's easy to lay the drawer side across the plane body and the clamped drawer front and transfer the outline of the tails to the pins by marking with a knife or an awl.
—Anthony Guidice, St. Louis, Mo.

Quick tip: The world's finest sanding block for curved surfaces is a piece of piano felt $\frac{7}{16}$ in. thick. A piano tuner will know where to get the stuff.
—David Sawyer, East Calais, Vt.

Tenon gauge

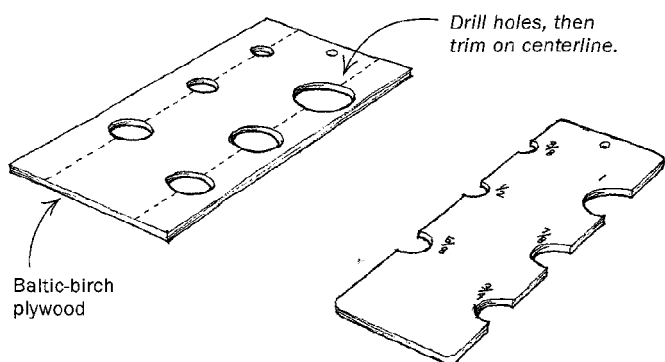

This gauge lets me check the size of turned tenons in a flash. Make the gauge from Baltic-birch plywood, which resists dimensional

changes with fluctuations in humidity. Sand and finish the gauge before you drill the holes so that the operations will neither add nor subtract from the final dimensions.
—R.B Himes, Vienna, Ohio

Drawer pulls from a turned block

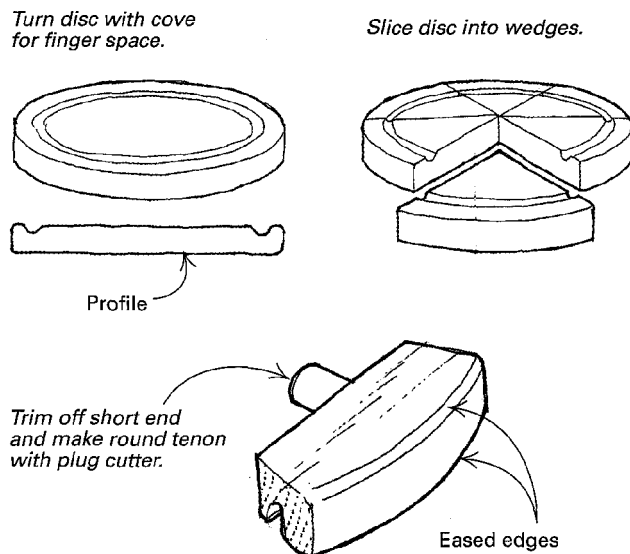

To make unique walnut drawer pulls for a bird's-eye maple bureau, I turned a 2-in.-thick, 8-in.-dia. disc on my lathe with a cove-shaped groove on the underside for finger space. On a band-saw, I sliced the disc into six pie-shaped pieces and trimmed off the short ends of each. Next I cut square tenons on the short ends of each piece and made those into dowels, or round tenons, using a plug cutter. I then drilled holes for the tenons in the drawer faces for installing the pulls.
—David St. George, Old Lyme, Conn.

Setting a tablesaw blade at 90°

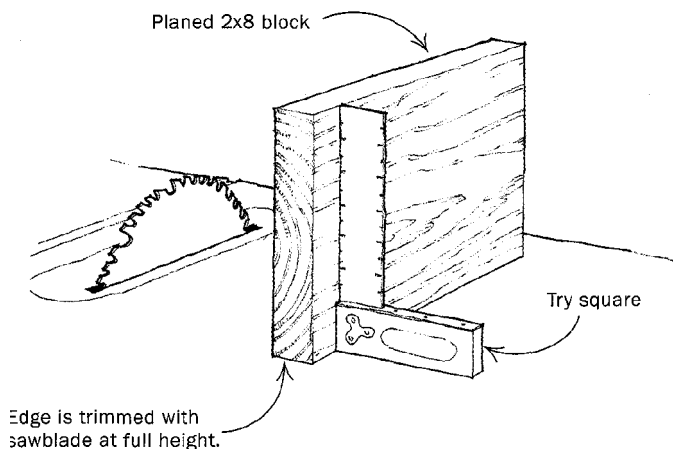

The time-honored way for setting a tablesaw blade so that it cuts a true 90° angle is to raise it up to its full height and put a square against it, carefully avoiding any of the teeth. I used this method

Methods of Work (continued)

for many years but never found it completely satisfactory for two reasons. If you have a wobbling blade or a throat insert that isn't level, you don't get an accurate reading.

I now use another technique that's easy to set up and totally accurate. Select a piece of 2x8 scrap a foot or so in length and plane both sides of it. Trim both edges of the block with the blade fully raised. Remove the sawdust from the saw table and stand the block on one of the freshly trimmed edges. Place a try square against the block. A board this wide and this thick will give a highly accurate reading against a good square. Adjust the tilt of the blade and trim the block again, until the cut is perfectly square.

—Thomas J. Brooks Jr., Jackson, Miss.

Quick tip: Use a lever-arm paper cutter, available at any office supply store, to cut sandpaper. The built-in ruler makes the job simple and quick. Also, the cutter does not get dull quickly, as you might expect. Mine has been in use for more than five years and still cuts like new.

—Ed Reiss, Berea, Ky.

Router ramp for pocket holes

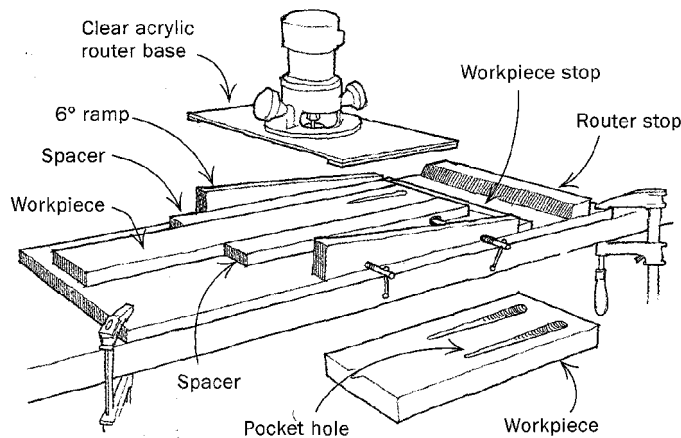

I built this router-based pocket-hole ramp when I became frustrated with my drill fixture. The router slides down the ramps to cut a low, 6°-angle pocket hole. It's quick and simple. There's no shifting of the workpiece and no frayed edges on the cut.

To make the fixture, attach two 6° ramps on each side of a plywood base. Install T-nuts and bolts in one of the ramps to provide a clamping system for the workpiece. Attach stops for the workpiece and the router at the base of the ramp. The distance between the router stop and the workpiece stop will determine the depth of the pocket hole, so position the stops carefully. Also, you will need to make an acrylic or Plexiglas base for your router. Add 1/4-in.-thick guide rails to the underside of the base to ride on the outside of the ramps.

To set up for a cut, place the workpiece in the fixture against the stop, positioning the workpiece so that the pocket cut will be in the right location. Drop in some scrap spacers to hold the workpiece in position. Tighten the clamps. Chuck a 3/8-in. round-nose bit into the router. With the router in place at the top of the ramps, turn it on, and slide it down to the router stop to make the pocket hole. Drill the pilot hole in the pocket after the workpieces have

been clamped together. Use a 6-in. pilot bit and driver to keep the screw angle low.

—Michael Csontos, Prescott, Ariz.

Spring clips for clamping

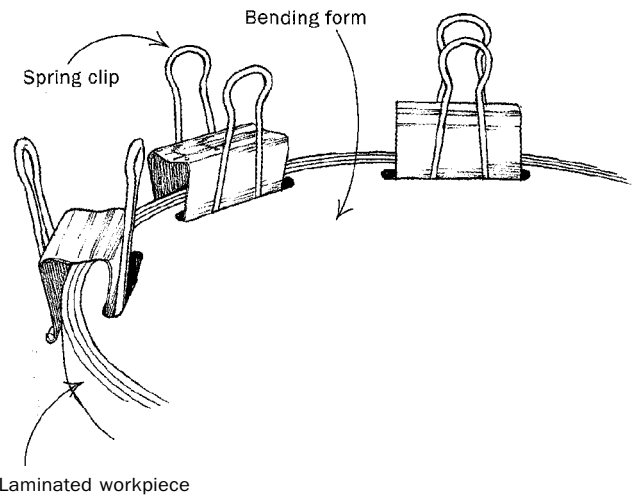

When making bentwood laminations, I had never had enough clamps, until I began using spring clips available at the stationery store. The clips come in several sizes and are cheap, lightweight and strong.

—Steve Borton, Vancouver, B. C., Canada

Auxiliary planer bed

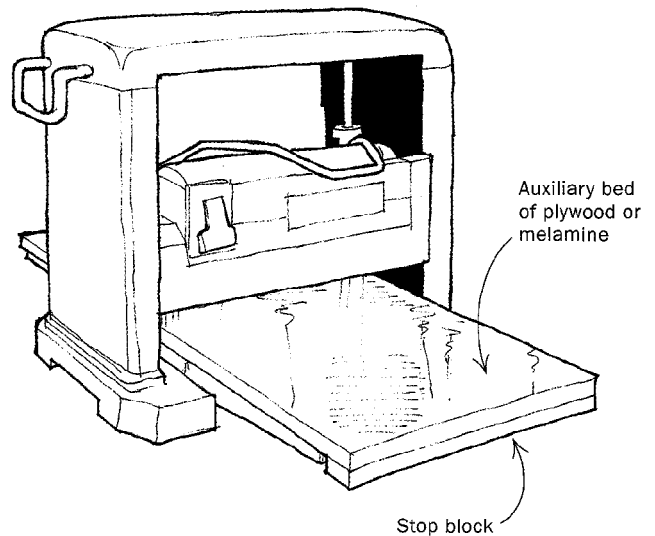

I use a piece of 3/4-in. plywood over the bed of my thickness planer when I plane thin boards, to avoid lowering the head so tightly. This fixture also reduces snipe. Attaching a stop block to the underside of the fixture will prevent it from moving through the planer. For better wear and reduced friction, you could also make the fixture from melamine.

—Omar Showalter, Harrisonburg, Va.

Methods of Work

EDITED AND DRAWN BY JIM RICHEY

Roughing out ball shapes on the lathe

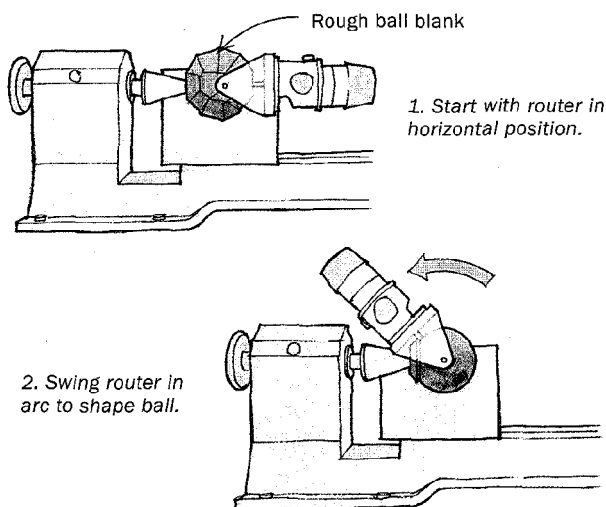
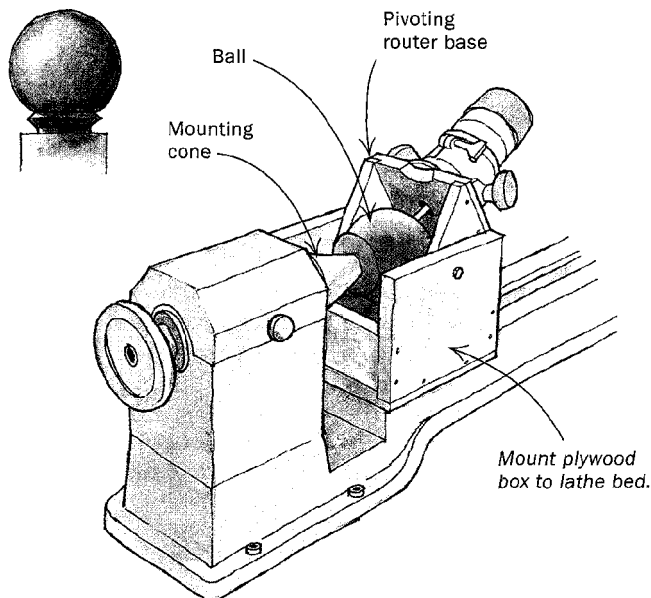

It bugged me that when I needed a number of uniformly sized wooden balls for bedpost finials, the only way to make them was to turn each ball from scratch—a painstaking operation. So I came up with this router-based fixture that whips out a rough ball in less than a minute.

To make the fixture, attach a simple plywood box, open at the top, to your lathe bed. Install a pivoting router base, as shown in

the top drawing at left. If you want to make perfectly round balls, carefully locate the pivot points right on the axis of the lathe centers. You can also make some interesting eccentric shapes by lowering the pivot point below the centers.

To attach the ball blanks, screw a block of wood to a faceplate and turn the block so that you have a truncated cone, roughly 6 in. long. Rough out a ball blank on the bandsaw and attach the blank to the cone with a large lag screw that runs through the back of the faceplate and into the ball,

To make a ball, start with the router in a horizontal position. Turn on the router, turn on the lathe and swing the router through its arc slowly to shape the ball (see the bottom drawings at left). You should be able to rough out about 90% of the ball, leaving a small, unfinished section where the ball attaches to the cone. Part the unfinished section off the bottom of the ball, and mount the ball using the lag-screw hole.

If you want a perfectly round ball with no hole—such as a croquet ball—make up a longer blank, so that when it is attached to the cone, the lag screw doesn't penetrate the ball. Rough out the ball, leaving a stem. Separate the ball from the stem and finish the ball by turning it 90° and chucking it between two cone-shaped centers so that you can waste away the stem. By chucking the ball in two or three positions and sanding the surface, you will achieve a virtually perfect sphere. —*Timothy Dalton, Middleton, Wis.*

Registering oddly shaped pieces

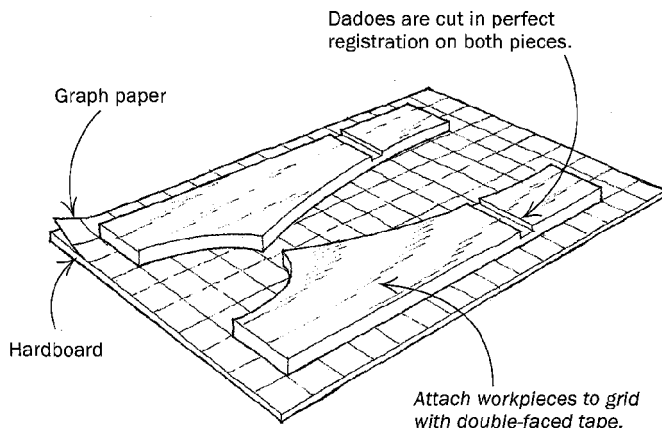

Here is a little trick that I discovered while making a display shelf for my wife. With this technique, I was able to keep two small, oddly shaped workpieces in exact registration to each other so that I could rout dadoes in them. I began by mounting graph paper

A new reward for the best tip

Tim Dalton, a cabinetmaker from Middleton, Wis., is the first reader to be awarded a Lie-Nielsen plane for sending in the best tip for this issue's *Methods of Work*. The plane is engraved with Tim's name, the Fine Woodworking logo, the issue number and the date. Tim's tip (see above) involves the ingenious use of a router and a lathe to make wood spheres. Send us your best tip—simple, complex, ingenious or so obvious you wonder why no one else has thought of it—and you might get a plane just like the one we gave Tim. Send details, sketches—we'll redraw them—and photos to *Methods of Work*, Fine Woodworking, P.O. Box 5506, Newtown, CT 06470-5506.

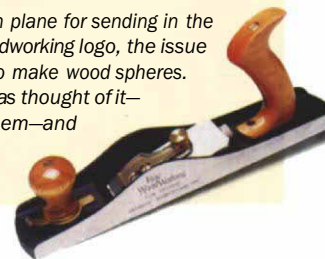

Methods of Work (continued)

on a squared-up piece of hardboard with spray adhesive. The grid lines on the graph paper allowed me to position the shelf sides on the hardboard in perfect registration to each other. I attached the shelf sides to the hardboard with double-faced carpet tape.

Finally, I flipped the whole thing upside down on the router table and made my dado cuts by running the hardboard against the router-table fence.

—Don DiPiero, Girard, Ohio

Small honing guide

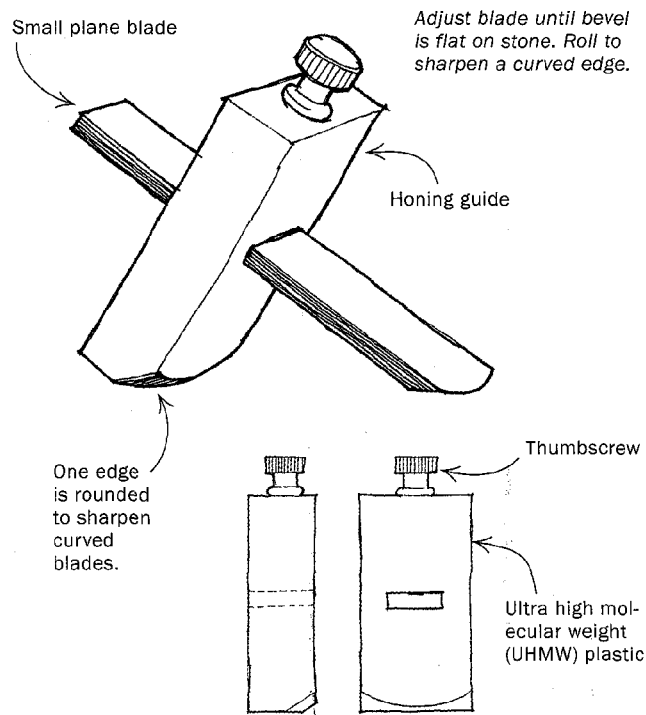

As a maker and user of finger planes designed for luthiers, I need to sharpen small plane blades at many different angles and radii. Commercial sharpening guides are too large to hold the small blades and will not allow a rolling motion to sharpen a curved blade. So I designed this little sharpening guide that solves these problems and makes blade sharpening faster and easier.

To make the guide, I use 1/2-in.-thick ultra high molecular weight (UHMW) material, a dense, slippery plastic sold in small sheets to make jigs and fixtures. Woodcraft (800-225-1153) is one supplier. Cut a block of UHMW about twice as wide as the blade and tall enough so that the blade will be centered in the guide when it is being sharpened at the desired bevel angle.

To cut the slot in the UHMW, use a router bit the same thickness as the blade chucked into your drill press. Work the block back and forth against a fence, gradually deepening the slot until you cut through. Then drill and tap a hole through the top down to the slot, and install a thumbscrew to hold the blade in place.

For curved blades, draw a radius onto the bottom end of the guide that will approximate the radius in the blade. Using a sharp knife or chisel, cut away the material but only to half the thickness

of the block. This allows you to insert a blade from either direction and sharpen a flat or a curved blade.

—Christopher Laarman, Philomath, Ore.

Sanding concave surfaces with a random-orbit sander

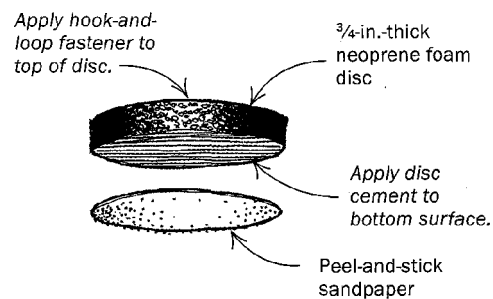
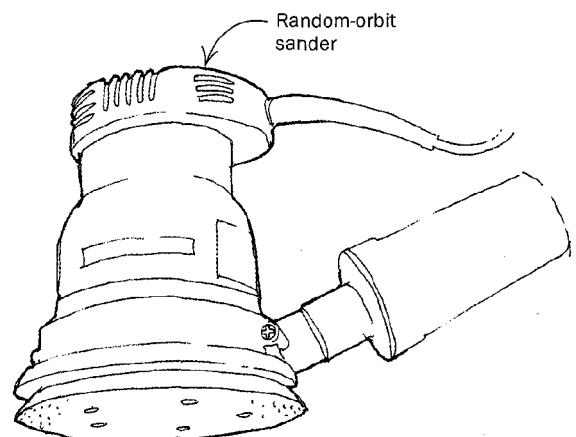
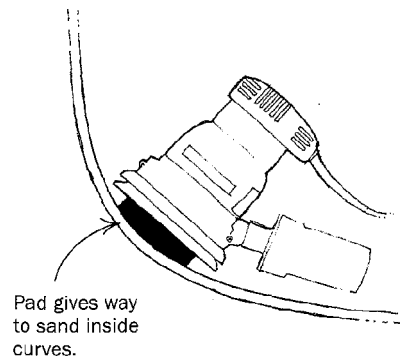

I love my random-orbit sander, which removes material fast, is easy to control and leaves a smooth, uniform surface. When I made a cedar-strip canoe last winter, the random-orbit sander worked like a dream on the outside of the hull, shaping and smoothing the convex curves. On the inside of the hull, however, I was able to use the sander only in some of the flatter areas because the 5-in. pad bridged all but the shallowest concave curves, leaving swirls and gouges at the edges.

After trying a number of solutions, all ineffective, I extended the reach of my sander by adding an auxiliary disc. I cut a 3-in.-dia. disc from 3/4-in.-thick neoprene foam and attached a hook-and-

Methods of Work (continued)

loop fastener to one side with polyurethane glue. I sealed the other side with Franklin sanding-disc cement, ending up with something that looked like a Nerf hockey puck. You can buy neoprene pads of different thicknesses at computer-supply stores or by mail order from CGR Products in North Carolina (336-621-4568).

By centering the auxiliary disc on my Sander's hook-and-loop pad and using self-stick sandpaper sheets, I was able to reach into almost all of the concave surfaces on the inside of the hull. Smaller discs or softer foams would likely extend the Sander's reach into even tighter curves.

Take care in accurately cutting the foam disc and centering it on the sander pad. Any imbalances could result in increased vibration at high speeds, which would be transmitted directly to the user's hands and arms.

—Philip Jacobs, St. Paul, Minn.

Production setup for the chopsaw

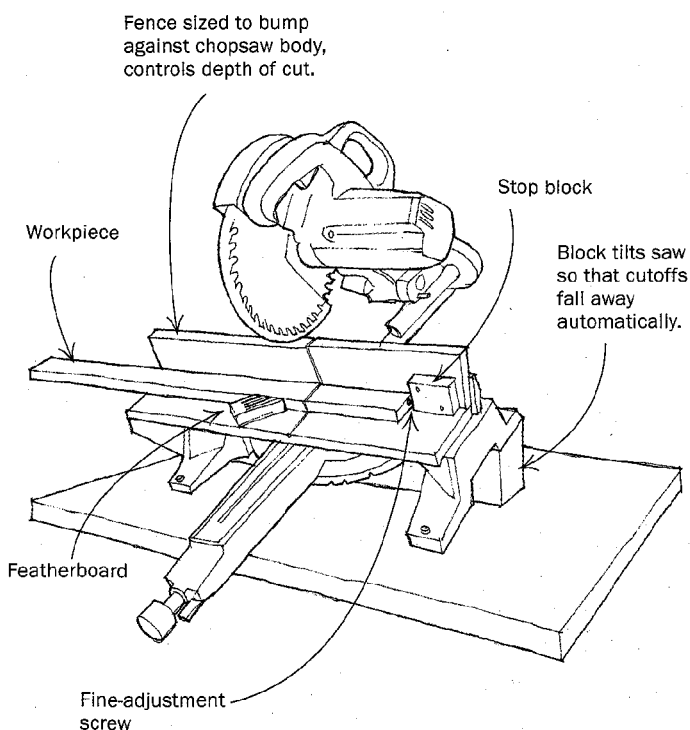

When cutting hundreds of identical pieces of wood to length for production work, a chopsaw is essential but not sufficient. To speed up cutting time, you need automatic removal of the sawn pieces. The easiest way to achieve this is to tilt the saw forward by attaching a 5-in. spacer board underneath the rear of the saw.

A simple jig is then clamped to the saw table to give you accurate results. The floor of the jig should be melamine or vinyl-coated to allow the pieces to slide off the jig easily. Secure the jig firmly to the saw. To help avoid tearout, screw a fence to the back edge of the jig. Cut the fence to the proper height so that it bumps against the saw body and acts as a depth stop, too.

—On the fence at the distance of the cut, plus 1/2 in., screw a stop block equipped with a flat-head screw for fine adjustment and sawdust clearance. Finally, you need to screw a featherboard to

the floor of the jig to keep the workpiece against the fence.

This jig is so easy to build that you can have one for each length you need to cut. You will save the time you spent building the jig the first time you use it,

—Klas Wilzen, Glimmingeg, Malmo, Sweden

Fixture for duplicating profiles on the lathe

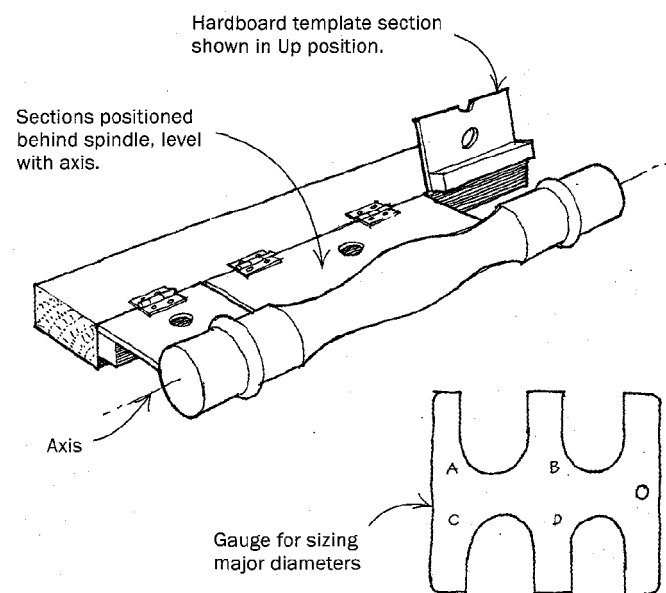

I don't own a duplicating lathe. So when I needed to turn several identical spindles, I designed the fixture shown in the sketch above. It was convenient to use and saved me a lot of time.

To make the fixture, first cut a negative profile of the spindle shape from 1/4-in. hardboard. Divide the profile into convenient sections, and attach the sections with hinges to a support piece behind the lathe bed, level with the turning axis of the lathe.

Prop up the sections in the open position out of the way and turn the spindle to rough dimensions. Use a simple gauge as shown to size the major diameters—it's faster than using adjustable calipers.

Continue to turn the spindle, approximating the shape by eye. When you get close, flip down a template section in the area you are working so that it is riding on the turning spindle. Continue to remove material and refine the shape until the template drops into place. Repeat that process until all of the sections have been duplicated. With just a little care, you can hold tolerances to within 1/32 in. For final sanding of the workpiece, flip the templates sections up out of the way.

—Richard Herst, Redondo Beach, Calif.

Quick tip: I use plastic-coated playing cards to keep pipe and bar clamps from marring a project's surface. Before a glue-up session, I slip an old deck in my shirt pocket. Then, as I go about positioning the clamps, I slide one or two cards under each clamp pad. Not only does the card's plastic surface keep it from absorbing wood glue like paper or cardboard does, they're thinner and more easily positioned than wood shims.

—R.B. Himes, Vienna, Ohio

Methods of Work

EDITED AND DRAWN BY JIM RICHEY

Copying cornice molding on the tablesaw

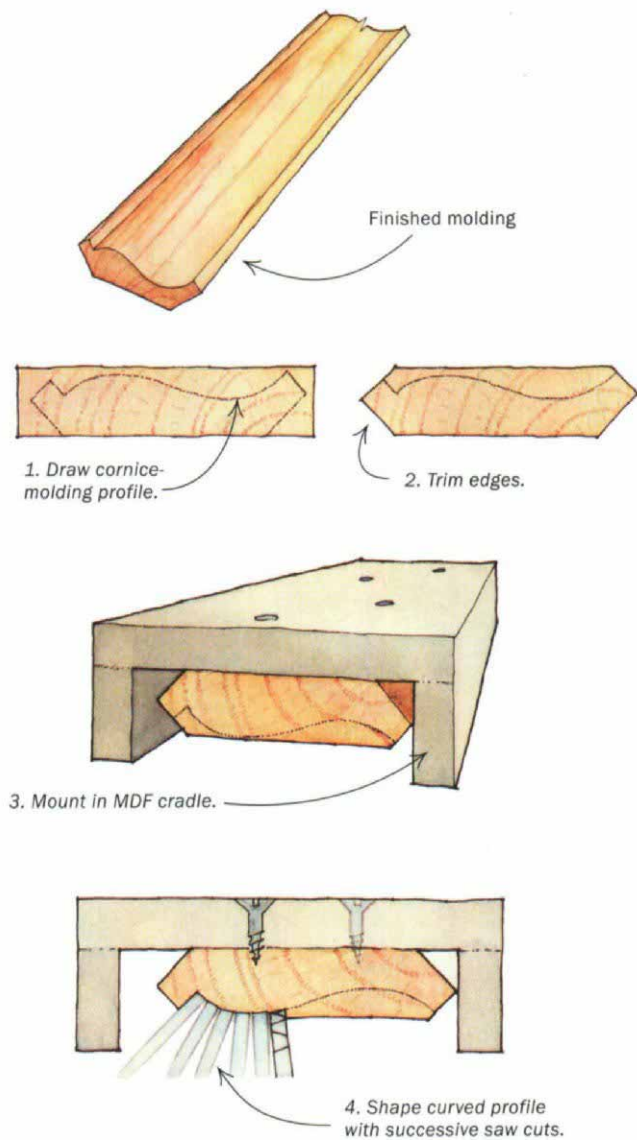

While remodeling a Victorian-style wood-paneled bathroom, I needed one 5-ft. length of cornice molding to complete the job. After striking out with local suppliers and running up some hefty long-distance phone bills, I found that it would cost about \$150 to make the custom knives to run one 5-ft. piece of molding.

Recalling the many times I've cut simple cove moldings on my tablesaw, I had a sudden brainstorm that would enable me to make the cornice in my shop. First, I drew the molding profile on both ends of a blank, a little longer than 5 ft. Then I made two 45° bevel cuts on each edge of the blank to define the top and bottom edges of the molding. Next, I built a cradle of ½-in. medium-density fiberboard (MDF)—a bit longer and slightly wider than the workpiece. I screwed the workpiece to the inside of the cradle, facedown, as shown at left. The cradle eliminates the problems that would result from cutting away the surfaces of the molding if I tried to mill it directly, facedown on the saw.

I made a series of cuts to define the profile, working from both sides of the cradle. For each cut, I tilted the blade to cut as close to 90° to the face of the curve as possible. This makes a cleaner profile and minimizes some of the steps and grooves that have to be scraped and sanded away to complete the shape. After some sanding, I had a cornice molding that was indistinguishable from the original and the satisfaction of proving to myself that it could be done. I also saved \$150 to boot.

—Ross M. Greer, Alexandria, Ont., Canada

Jointing mitered segments with a router

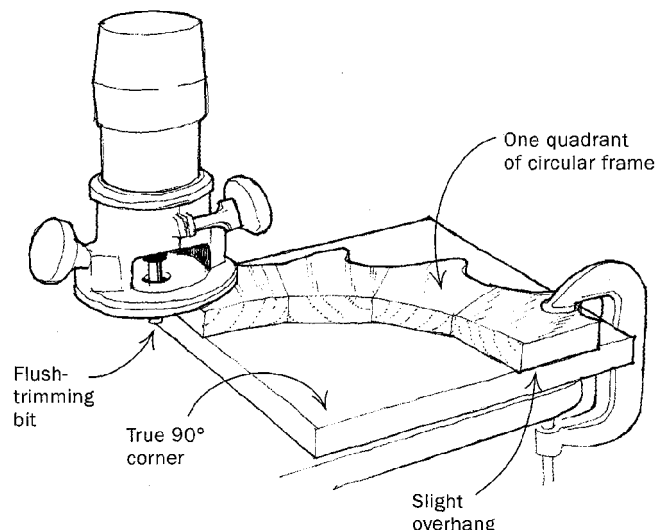

While making a round sunburst mirror frame consisting of 16 segments, I had to miter both sides of each segment at precisely 11¼° on my tablesaw to get a gap-free fit. Rather than trust the accuracy of the saw cut, I came up with another approach.

I started by cutting each segment as close as I could to the proper angle and then glued up four segments at a time to form the

A reward for the best tip

Ross M. Greer is the second reader awarded a hand-engraved Lie-Nielsen plane for the best tip. His simple method of cutting cornice molding (see above) personifies that latent talent most woodworkers possess: finding frugal solutions to otherwise expensive and complicated problems. Ross is a retired newspaper publisher from Alexandria, Ont., Canada. He learned woodworking from his father, who was a pattern maker for the Titanic. Send us your best tip, and you might get a plane just like the one we gave Ross. Send details, sketches—we'll redraw them—and photos to Methods of Work, Fine Woodworking, P.O. Box 5506, Newtown, CT 06470-5506.

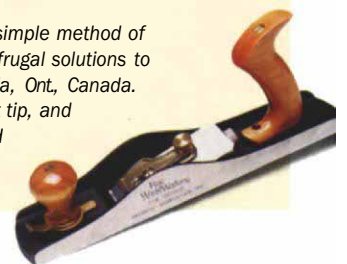
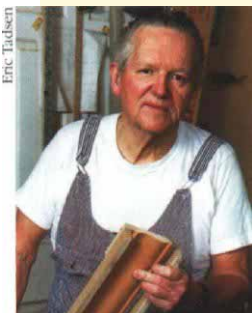

Methods of Work (continued)

four quadrants of a circle. I then positioned one quadrant at a time on a perfectly square board so that an equal amount of the quadrant overhung each edge of the board. I clamped the quadrant in place and trimmed off the overhang, using a flush-trimming bit in my router.

When all four of the quadrants were trimmed in this way, I dry-fitted them to check for a tight joint that would require minimal clamping pressure. No further trimming was needed, but if it had been, I would have glued up two semicircles and trimmed the edges with a straight board. —Anthony Fudge, Snow Hill, Md.

Retracting workbench

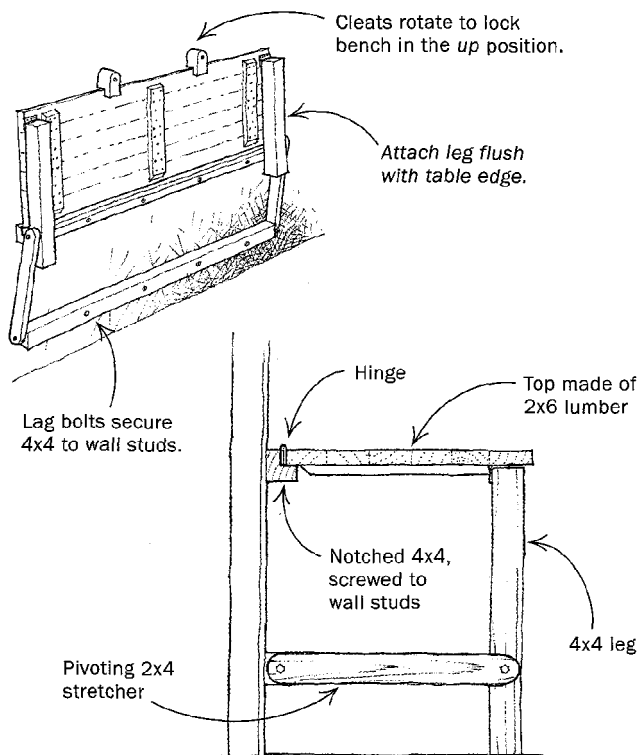

When I saw Dave Gillis' retracting workbench (*FWW*#127, pp. 36, 38), it reminded me of one I built years ago in a one-car garage shop. When a friend told me, "You can't make a retracting workbench strong enough or stable enough," I designed this bench to prove him wrong. The bench is screwed to the wall for lateral rigidity and is rock solid, even under heavy loads. When I fold it up out of the way, I have plenty of room to drive my car into the shop.

—Mike O'Banion, Westminster, Md.

Chip-free melamine cuts

I have been using this technique for producing chip-free edges on melamine-covered particleboard for many years. The technique is a variation of scoring veneered panels with a straightedge to pre-cut the wood fibers and prevent tearout.

I score a line through the hard, brittle surface of the melamine with a carbide-tipped scoring tool commonly available for cutting plastic solid-surface materials. Any chipout from a subsequent

sawcut will stop at the scored line. To cut the panel, you can use a tablesaw, a portable circular saw or a jigsaw.

It's important to make the score cut inside of where the sawcut will be. After making the rough sawcut, square the edge to its final line using a straight router bit and a straightedge guide. Carbide-tipped blades are essential. With a little care you can make perfect edges every time, material waste is minimal and, best of all, the technique doesn't require a big investment in new tools or equipment. —Ben Terlecki, Burlington, Ont., Canada

20-ft. tablesaw fence

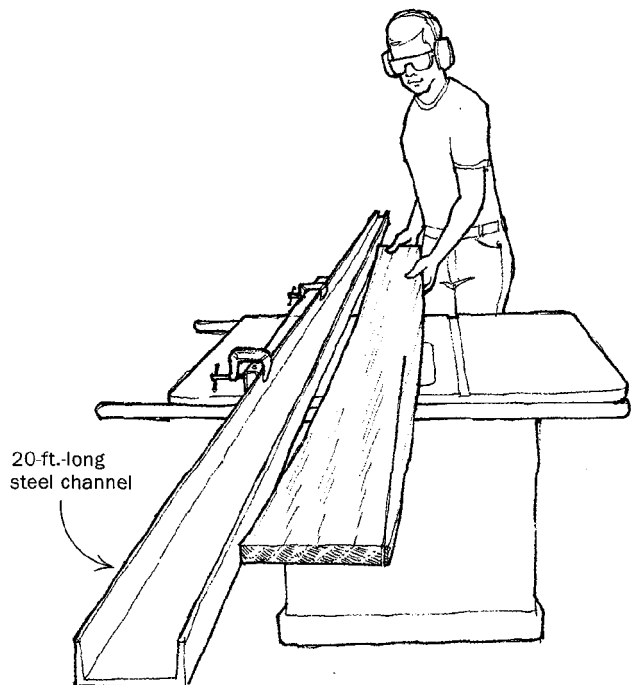

When faced with the task of straightening the warped edges on several hundred feet of 12-ft-long 1x12 stock (for an order of baseboard), I remembered a previous *Methods of Work* contribution in which the reader clamped an 8-ft. piece of aluminum channel to the tablesaw rip fence. Then I remembered seeing a straight 20-ft.-long piece of steel channel, 1/4 in. thick, at a local metal shop. Without a second thought, I went back to that shop and left with the channel on the roof of my pickup.

I clamp the channel to my existing rip fence as shown above and run the concave edge of the board against the fence so that only the ends touch the long fence. After I've ripped one edge of all of the stock, I remove the auxiliary fence and rip the other edge of the lumber using the regular fence. In my shop, most stock now passes through this low-cost, very efficient, straight-ripping process right after planing. I store the fence overhead on two plywood hooks. I can lower my new 50-lb. helper onto the saw table one end at a time. —Mike McKenna, Ayer's Cliff, Que., Canada

Quick tip: A coating from a black permanent marker on the bevel of a chisel will show you exactly where the grinding wheel is touching. The mark doesn't wash off when you dip the tool in water to

Methods of Work (continued)

cool it. And when all of the black is gone—right up to the edge—you know you're done. —*Charles Schafer, Annandale, Va.*

Rolling scrap-storage bins

Rolling scrap-bins nest together and fit under workbench.

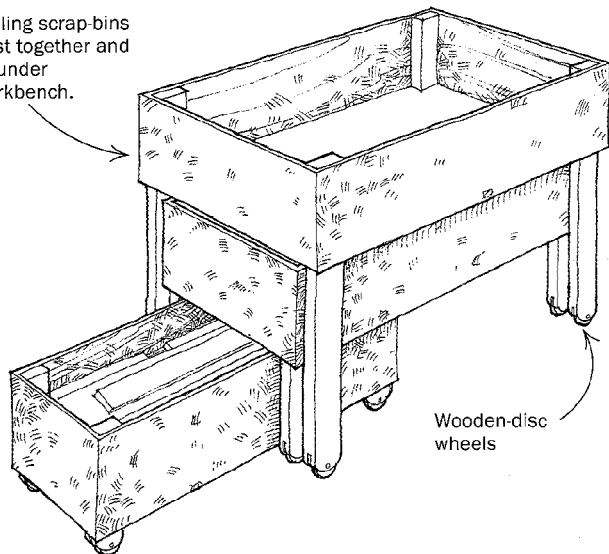

When I needed more room to store wood scraps, I built these rolling bins to fit under my workbench. One advantage to this set-up is that I can pull a bin out all the way to get a good view of the wood stored inside. I made the sides and bottoms of the bins from oriented-strand board (OSB) and the legs from yellow pine. The wheels are oak discs. —*Stan Kessler, Ft. Wayne, Ind.*

Eye-protection cleaning station

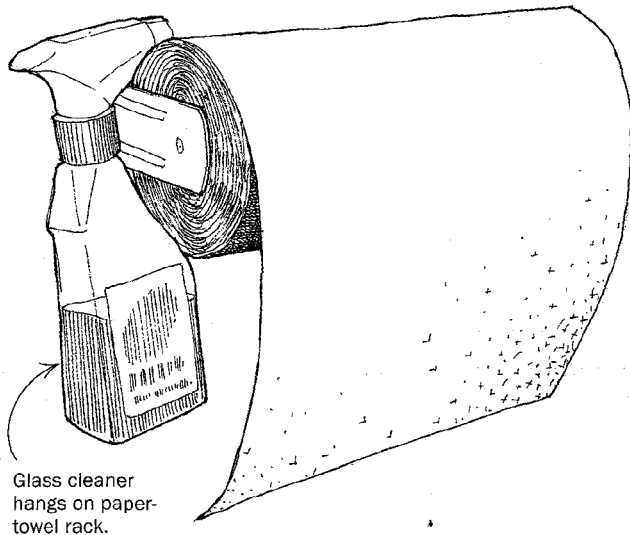

No one in my shop likes to wear eye protection. Glasses and goggles get fogged up and scratched, and they attract dust like magnets. But after having debris surgically removed from my left

cornea, we all got serious about eye protection. Now we hang a bottle of glass cleaner on a paper-towel dispenser to make an eye-protection cleaning station. The ammonia in the glass cleaner seems to repel dust and keep the lenses from fogging up.

—*Chris Black, Clifton, Va.*

Compound miters made simple

1. Make cut with blade at 90° and at full height.

Set miter gauge at 45°.

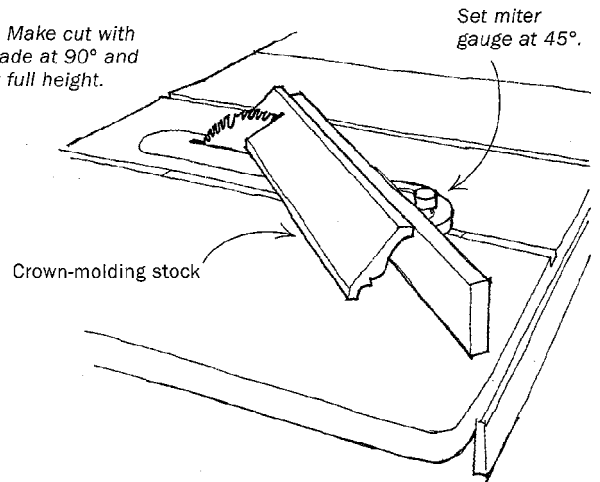

2. Lay back of molding on saw table, use scrap to set blade-tilt and miter-gauge angles.

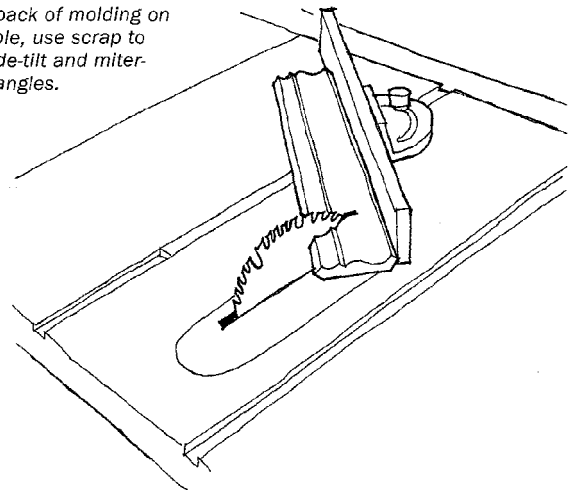

Here's a simple, foolproof solution for finding the proper blade-tilt and miter-gauge angles for mitering crown molding on the tablesaw. Set the miter gauge at 45° and the sawblade at 90°. Crank the blade up to full height. Place a scrap of the molding with the top face flat against the miter gauge and the bottom edge flat on the saw table, and make a cut. If the blade cuts all the way through the molding, go ahead and cut the miters using this setup. With most large crown moldings, however, you will find that the blade—even at full height—will not cut through the molding.

If that is the case, you can use the scrap piece as a guide. The cut in the scrap piece, laid flat on the tablesaw, will show you the needed blade-tilt and miter-gauge settings. With the saw turned off, tilt the blade until it just slips into the cut in the scrap piece, then set the miter gauge to fit snugly against the molding. That's it. No calculations are required. —*Tim Hanson, Indianapolis, Ind.*

Methods of Work

EDITED AND DRAWN BY JIM RICHEY

Half-lap face frames

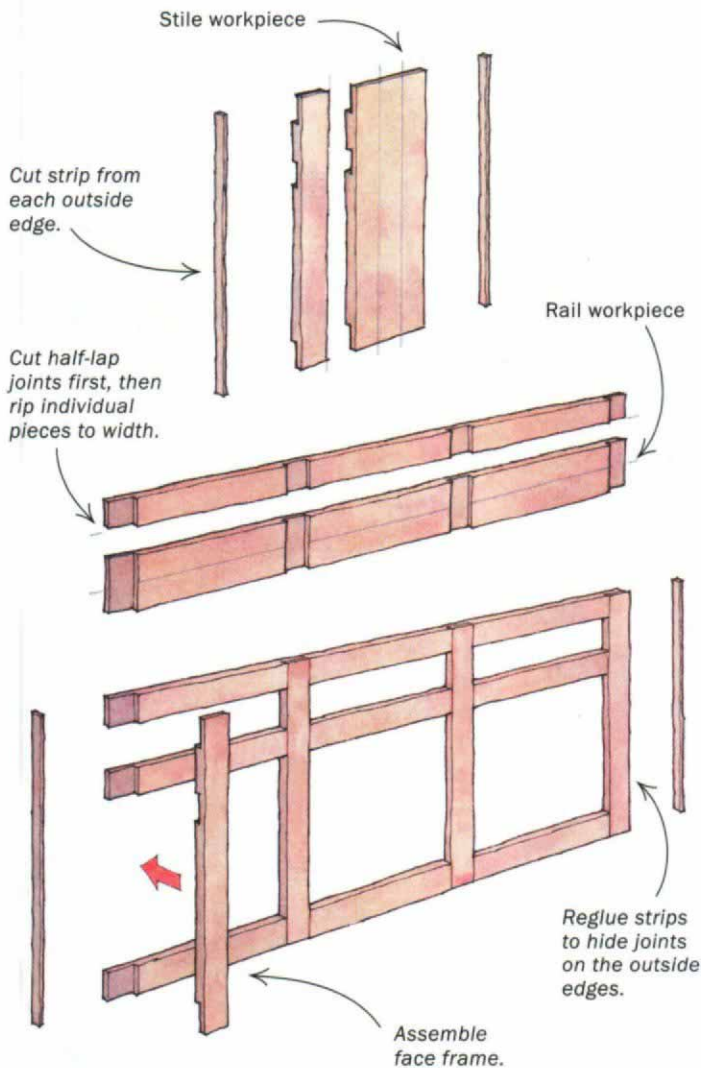

Here's a fast and simple method to make cabinet face frames entirely on the tablesaw. Start with two wide pieces of stock, one for the stiles and one for the rails, surfaced to the finished thickness and crosscut to the finished length. It is key to have stock that is wide enough to rip all of the finished pieces, including some spare room for the rip kerfs and plane shavings. If necessary, edge-glue two or more pieces to get the width you need.

If the finished face frame is to be part of a freestanding cabinet that will be seen on all sides, rip a 1/4-in.-wide strip off each edge of the stile stock. These strips will be reglued after the face frame

has been assembled and will hide the half-lap joints on the outside edges. If those edges of the cabinet will be hidden, you can skip this step.

With a square and a pencil, mark the edge of each piece where all half-lap intersections occur. Note that the laps are cut into the front faces of the rails and the back faces of the stiles. Set your sawblade or dado blades to cut just slightly deeper than half of the stock thickness to allow for glue. Cut each edge of each half lap. (Scribe lines on the throat plate of your tablesaw to make this easier and more accurate.) Once you have cut the outside edges of each half-lap joint, waste the remainder with repeated passes.

When all of the laps have been cut and cleaned up, rip the finished stiles and rails from each piece of stock. I like to set the fence for a rip that's just a hair wide, then finish the edge with a couple of handplane strokes or jointer passes to remove saw marks and to make a nice press-fit at the joints.

Assembly is simple. If the half laps fit tightly, the whole thing is self-squaring, but check it anyway. Glue up the face frame on a flat surface and tap a couple of short nails or brads into each intersection. To complete the frame, glue the 1/4-in.-wide strips on the outside edges of the stiles. —*Michael Vegiard, New London, Conn.*

Fastening indicator for cabinet backs

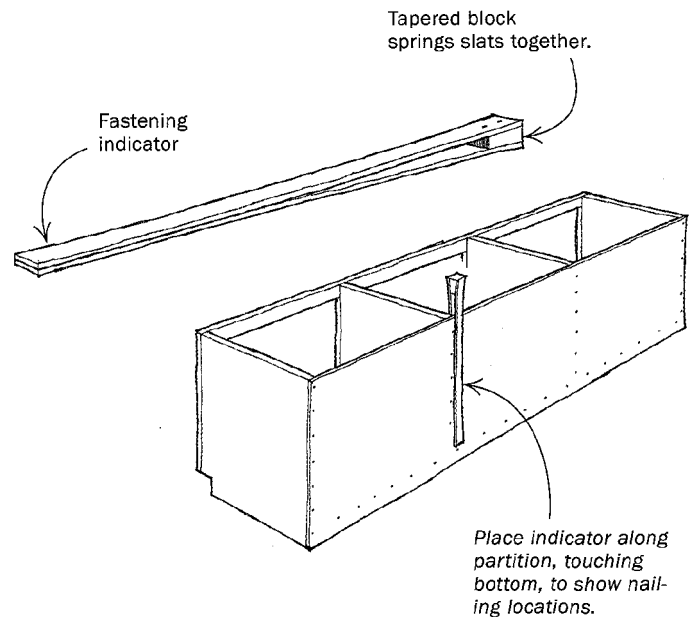

When fastening the backs to kitchen cabinets, it is difficult to know exactly where to locate nails or screws that secure the back to the

A reward for the best tip

Michael Vegiard was awarded an engraved Lie-Nielsen handplane for working out a method of making cabinet face frames that saves time and adds strength to the finished product. He cuts all of the joinery on the tablesaw. One big benefit of his method is that the half-lap joints automatically square up the frame when it's assembled. Michael builds cabinets as a second, part-time career. He's also a skipper for hire, sailing boats up and down the East Coast from his home base in New London, Conn. Send us your best tip, along with any photos or sketches (we'll redraw them), to Methods of Work, Fine Woodworking, P.O. Box 5506, Newtown, CT 06470-5506.



Methods of Work (continued)

cabinet partitions. Yes, you can get out your tape and then measure and mark. But there's a faster way—using a simple tool I call a fastening indicator.

To make the indicator, glue two hardwood slats, $\frac{3}{16}$ in. thick by 40 in. long, to a slightly tapered block, so the slats spring together at the other end. Slip the indicator over the back of the cabinet and slide it against a partition. The indicator will show you the locations of both the partition and the cabinet bottom. Drive a line of nails beside the indicator or just below its end.

—Tim Hanson, Indianapolis, Ind.

Shopmade center finder

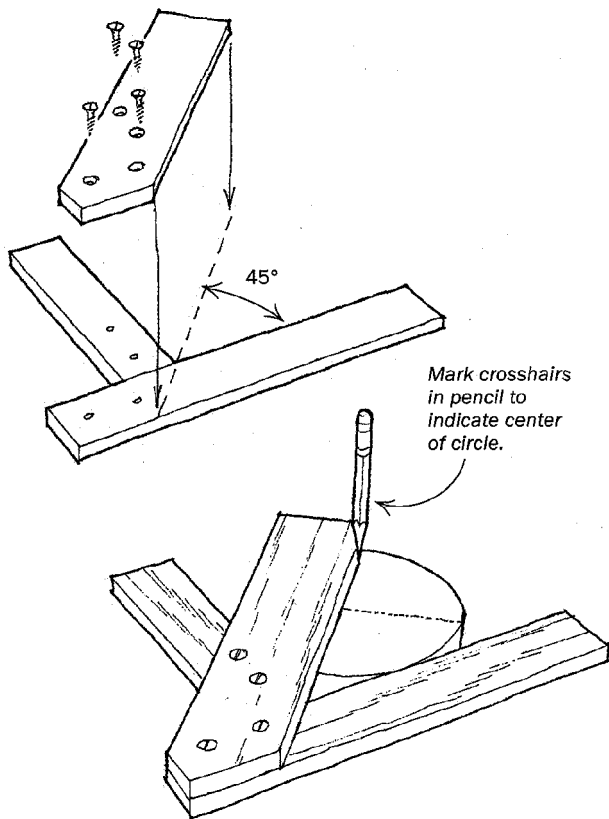

With this jig (above), you can find the center of round stock quickly and easily. Construction requires only three pieces of hardwood. Make two arms that form a 90° angle and a center member a little wider, so that all three pieces will interlock securely. Cut the length according to the largest-diameter round stock that you intend to use. To assemble the jig, locate, drill and countersink four holes in the center member. Carefully position the center member on top of the other two pieces so that one of its edges bisects the right angle. When everything is right, install the screws. Getting the angles true is the key to an accurate jig.

—Eric Orcutt, Tallahassee, Fla.

Quick tip: To reduce the dust that accumulates in plastic face shields, spray the plastic with furniture polish and rub the surface lightly until the water beads out of the wax. Then polish with a soft cloth until the surface is clean. Dust will not adhere readily to the

waxed plastic, and it wipes off easily. The wax also has the advantage of hiding some of the surface scratches on the plastic.

—Bob Hebre, Lexington, Va.

Stretching clamps

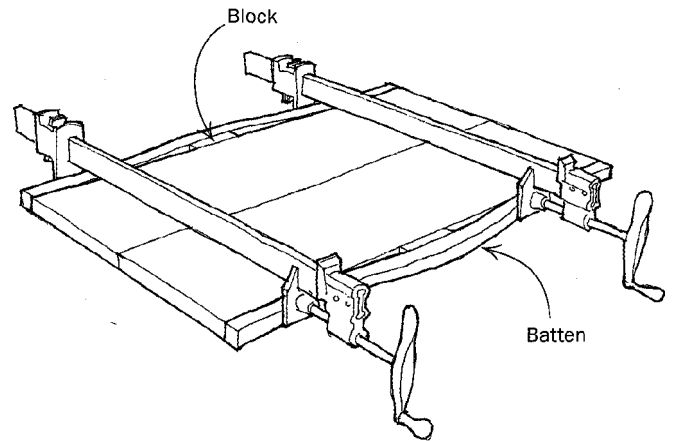

When gluing up several panels at once, I usually have a chronic shortage of clamps. Rather than waiting for the glue to set on one panel before going to the next, I make two clamps do the work of more by adding battens, one on each edge, and forcing them to bend over blocks of scrap wood in the center, as shown above. This arrangement applies clamping force not only at the clamps but also under the blocks. I can adjust the clamping pressure by changing the thickness of the battens or the blocks.

—Peter Sieling, Bath, N.Y.

Circular-saw guide for cutoffs

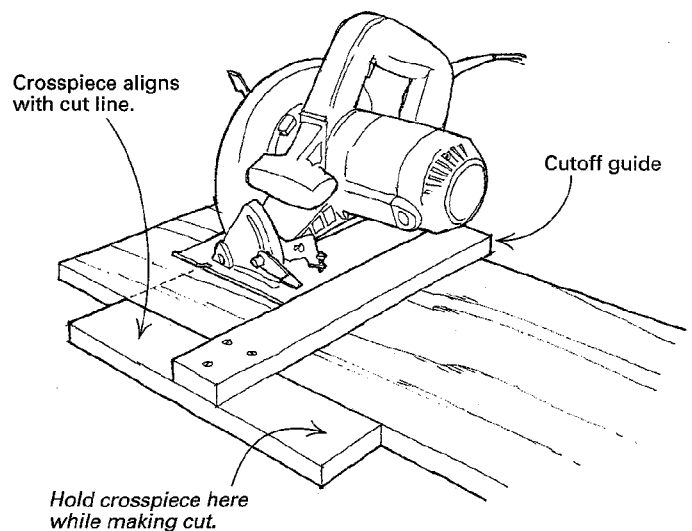

Crosspiece aligns with cut line.

Cutoff guide

Hold crosspiece here while making cut.

Here's a variation on Gary Allan May's circular-saw fixture (*FWW* #126, p. 30). This one was adapted for cutting framing and shelving lumber to length. It certainly saves a lot of time measuring, squaring and marking stock for repetitive cuts. To make the fix-

Methods of Work (continued)

ture, screw two straight pieces of plywood together into a T-shape, carefully aligning the pieces at a right angle. Leave the crosspiece a little longer than the width of your saw's base so that on the first trial your saw will cut to the precise length.

Thereafter, by aligning the crosspiece to the cut line of your workpiece, you set the fixture in precise alignment for the intended cut. The T-shape enables you to hold both guide and workpiece with one hand safely away from the saw, leaving the other hand to steer the saw against the guide.

—Pat McGowan, Sonoma, Calif.

Quick tip—For a quick drill-bit guide, install a bronze bushing in a piece of scrap wood. Bronze bushings are inexpensive and come in a variety of common, useful sizes. Drill a hole the size of the outside diameter of the bushing through a piece of scrap using a drill press. Press the bushing into the hole, clamp the scrap to the workpiece and drill away.

—Ken Werner, Hamilton, N.Y.

Cutting metal with a scroll saw

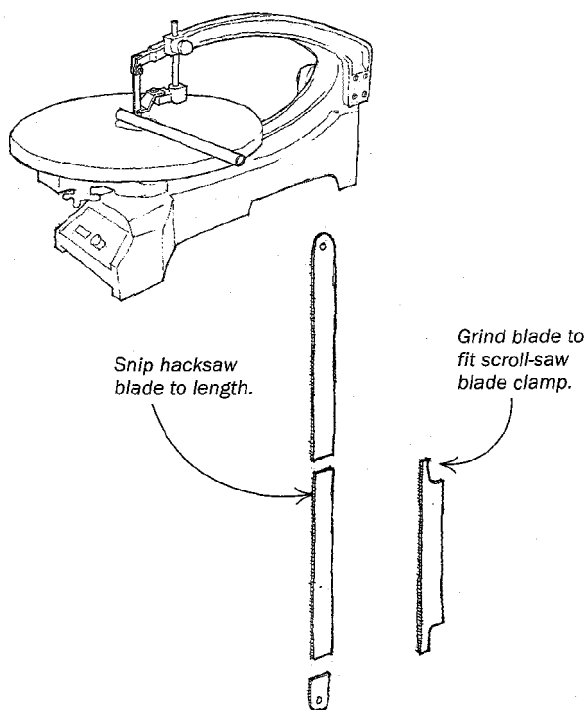

If you own a variable-speed scroll saw, you can easily turn it into a power hacksaw by modifying a standard hacksaw blade. With a good pair of tin snips, cut the hacksaw blade to the same length (probably 5 in.) as your scroll-saw blades. Grind the ends of the blade to fit your sawblade clamps. Clamp the blade in the saw, teeth pointing down, and adjust the speed to a slow 300 strokes per minute. Hold the workpiece firmly and use a very slow feed rate. Be especially careful as the blade completes the cut.

I have cut tubing, angle and flat plate in aluminum, brass and steel up to $\frac{1}{8}$ in. thick. You can also make internal cuts by first drilling an access hole. One thing I like about this method is that I

get straight cuts that require just the touch of a file to make them smooth. It sure beats a hand-operated hacksaw.

—Jim Miller, Milan, Ill.

Quick tip—Add wax to the sides of a mortise chisel when hand-chopping a mortise. The wax reduces binding as the chisel goes deeper into the mortise.

—Paul Coppinger, Piano, Texas

Wood hinges for entertainment-center doors

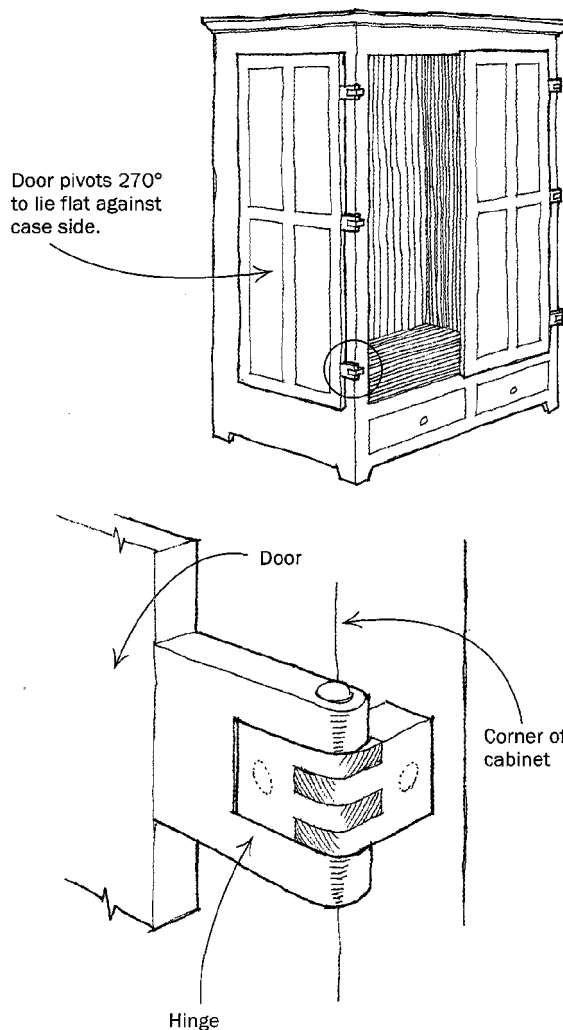

When I built a large entertainment center, I wanted the 5-ft.-tall doors to be out of the way when opened. So I designed wood hinges that pivot 270° and allow the doors to lie flat against the sides of the case. Each hinge has two parts: a finger-jointed, L-shaped piece that attaches to the corner of the cabinet and a U-shaped piece that attaches to the door. Round off the end of the U-shaped piece so that it doesn't rub against the case, then round off the corner of the L-shaped piece to match. Each hinge pivots on a turned hardwood pin.

—Stan Kessler, Ft. Wayne, Ind.

Methods of Work

EDITED AND DRAWN BY JIM RICHEY

Adjustable dust-collection port

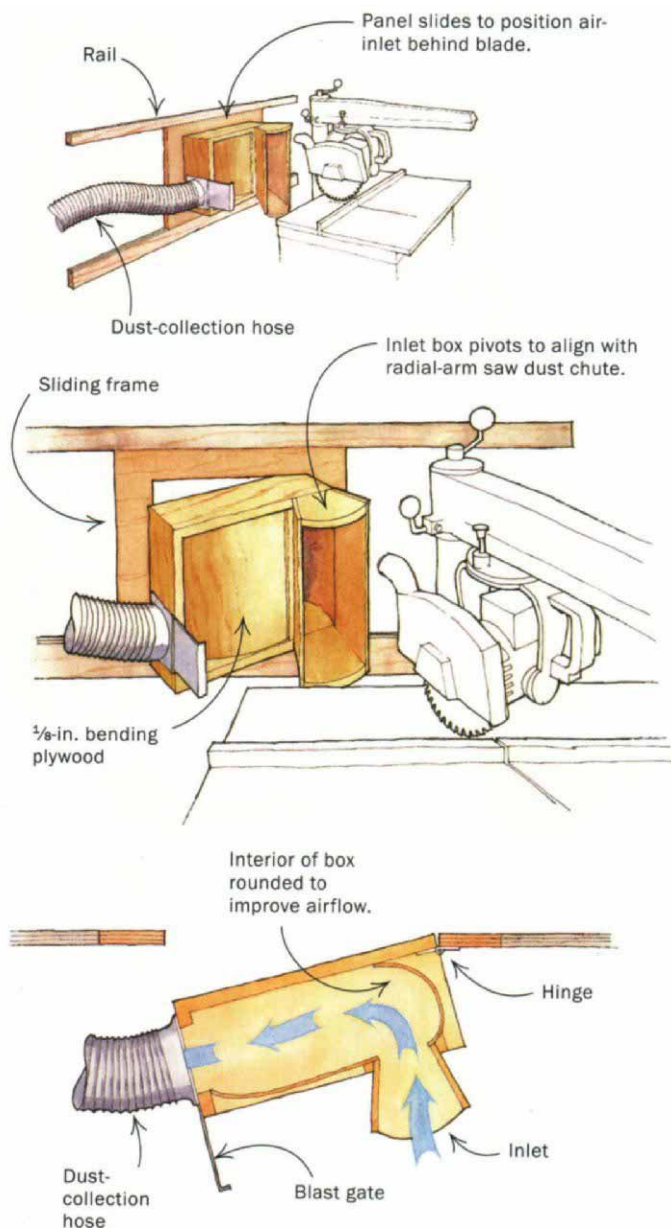

Collecting sawdust from a radial-arm saw is difficult because the sawdust is thrown in different directions, depending on the angle of the cut. Here's a solution that has considerably reduced cleanup

at my saw (see the drawings at left). The device is a movable dust-collection port that can be swiveled to catch dust at just about any angle the saw can throw it.

Make the inlet box from 3/4-in.- or 5/8-in.-thick plywood, then round the interior walls of the box with 1/8-in. bending plywood to improve the airflow and to avoid congestion. Attach a pair of rails to the wall with a sliding plywood panel between them. Hinge the box to the sliding panel and connect a gated dust-collection hose to the box. Make sure the collection hose is flexible and long enough to allow free movement of the hinged box.

Mount the box on the wall so that the floor of the box is about 2 in. below the level of the radial-arm table. That's it. Just remember to line up the inlet box with the exhaust chute of the saw before each cut.

—William C. Wright, Conroe, Texas

Tablesaw insert from a kitchen cutting board

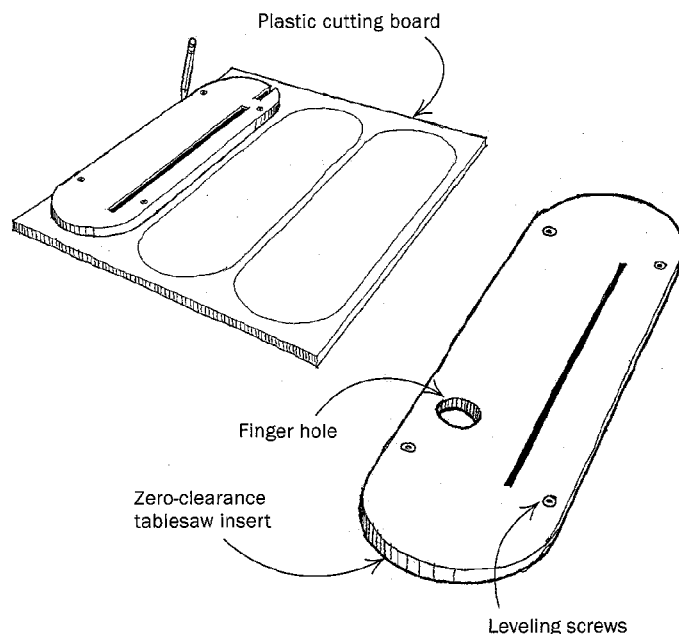

When I discovered the cost of aftermarket zero-clearance throat inserts for my tablesaw, I decided to make my own. I bought an ordinary white, high-density plastic kitchen cutting board, 1/2 in. thick. I marked and cut out several inserts, using the existing metal one as a template. I then drilled and tapped four holes in each insert to install leveling set screws. I also drilled a finger hole to make it easy to remove the insert from the saw table. The cutting-board material is ideal because it is inexpensive, friction-free,



A reward for the best tip

William C. Wright received an engraved Lie-Nielsen plane for the best tip in this issue. When we called to notify him, we learned that he already owned six smaller Lie-Nielsen planes and that he once visited the factory in Maine. William is a * retired architect who arrived at the design of his adjustable dust-collection port (shown above) as "just another solution to a problem." He keeps busy in his workshop on projects for his children and grandchildren. Send us your best tip, along with any photos or sketches (we'll redraw them) to *Methods of Work*, Fine Woodworking, P.O. Box 5506, Newtown, CT 06470-5506.

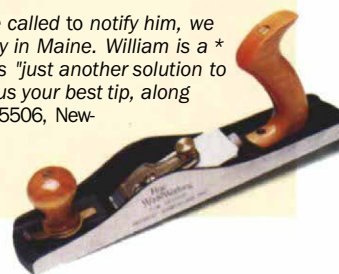

Methods of Work (continued)

dense and stable. I was able to make several inserts for less than the price of one commercially available piece.

—Scott Spierling, Sunnyvale, Calif.

Quick tip: I live in Vermont where the winters are long and cold, and my driveway is often icy. Instead of spreading sand and salt, once or twice each winter I cover the driveway with a layer of wood shavings. The shavings attract solar heat and quickly begin to melt into the ice, providing an incredibly nonskid surface. When the snow is gone, the shavings that have not yet decomposed simply dry up and blow away.

—Denny DeCoff, Stockbridge, Vt.

Retrofitting bar clamps for clamping leverage

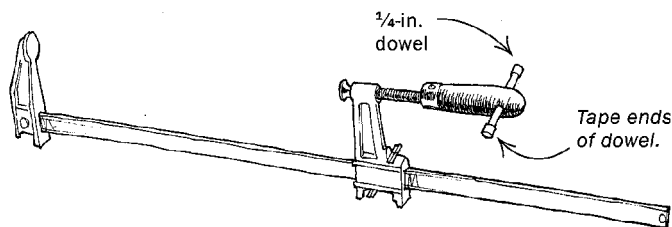

As a woodworker who occasionally suffers from carpal-tunnel syndrome, I have found a measure of relief by retrofitting my bar clamps with 1/4-in. dowels, as illustrated above. I first drill a 1/4-in.-dia. hole in the wood handle with a brad-point bit and follow that with a 3/32-in. twist bit to enlarge the hole enough so that the dowel slides freely. In that hole I insert a section of dowel just long enough that it doesn't interfere with the bar, and I tape the ends of the dowel so that it doesn't slide out of the handle.

The increased leverage enables me to tighten the clamps with much less effort and strain on my wrists, and I have yet to break a dowel or a clamp handle.

—Dan DeKoven, Evergreen, Colo.

Peg-Board template for adjustable shelf holes

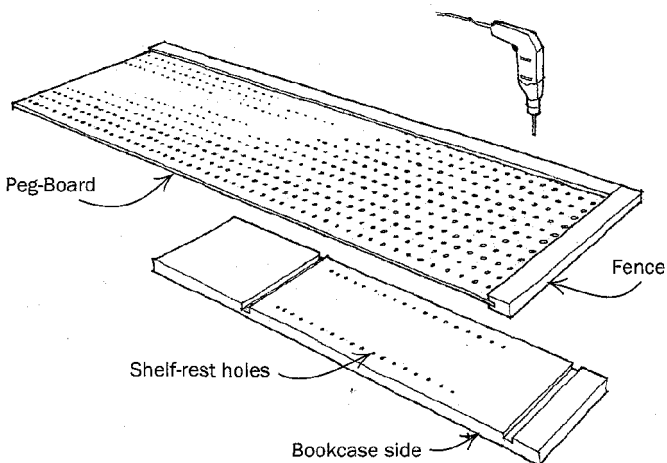

When I recently built a series of bookshelves, I made this simple template that allows me to drill the holes for adjustable shelf rests

quickly and accurately. The template takes advantage of the 1-in. spacing of the holes in standard Peg-Board. Starting with a 15-in. by 60-in. piece of Peg-Board, I glued and screwed plywood fences to one side and one end, carefully locating each fence at the centerline of a row of holes. This makes the first set of adjacent holes a convenient 1 in. away from the fences.

To use the template, I simply place it on top of the inside of my bookcase piece. By counting inches, I locate where I want to start and stop the holes, then drill a series of 1-in. spaced holes directly through the template.

—Michael Yost, McLean, Va.

Surfacing stock with a router

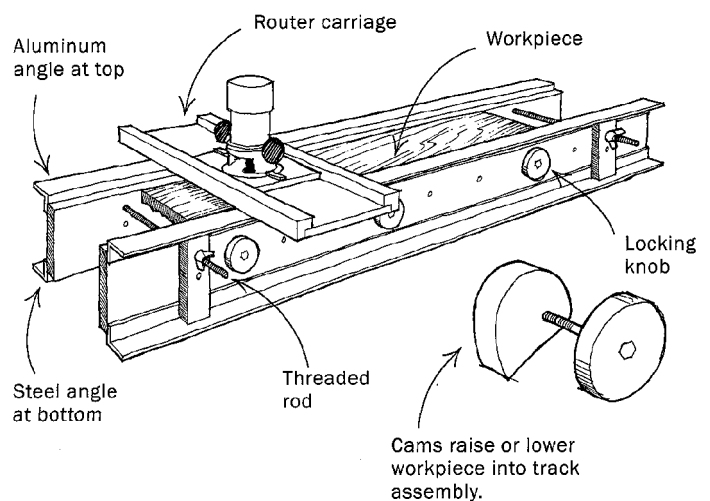

For the woodworker in a small, low-budget shop, Tim Hanson's router-surfacing fixture (*FWW* #77, pp. 42-43) offers the advantages of simplicity, accuracy and small storage requirements. When I set out to build Hanson's fixture, I couldn't find some of the components he used, so I revised the design as shown above.

As a substitute for the square, extruded-aluminum box girders in Hanson's fixture, I made the side rails of 1/2-in.-thick, 7-in.-wide pieces of hard maple. To stiffen the rails I added two angle irons to each one, iron below and aluminum at the top. The aluminum is a safety feature in case the rotating router bit ever contacts the metal. Other components include six cams with locking knobs, for aligning the top surface of the workpiece, some threaded rod to clamp the workpiece in place and a carriage for my router. For the surfacing I use a 1 1/4-in. mortising bit.

To use the fixture, set the rough board between the rails and adjust the cams to expose the desired amount of wood to the bit. Then lock the board in place by tightening the threaded rods, and plane the board from right to left, advancing about half the diameter of the bit with each new cut. Try to maintain a regular pattern of movement of the router and bit. When one side is finished, turn the workpiece over, readjust the cams, if necessary, and plane the other side.

There are two important points to consider in constructing and setting up this fixture. First, the height of the rails must remain uniform along their entire length. Second, the rails must both lie in the

Methods of Work (continued)

same plane. This must be carefully checked with a level at both ends of the rails. Failure to do this will result in a workpiece that has been carefully planed with a twist along its length. Install shims as needed between the bottom rails and the benchtop to level the top of the rails.

I wouldn't want to tackle 100 bd. ft. of lumber at one time with this fixture. But it does offer those with a small, low-budget shop the ability to work with rough wood and to mill it to any thickness. It joints and tapers with precision. And it produces a beautiful surface on curly woods that are difficult to work with other tools.

—John M. Van Buren, Herndon, Va.

A minisaw in minutes

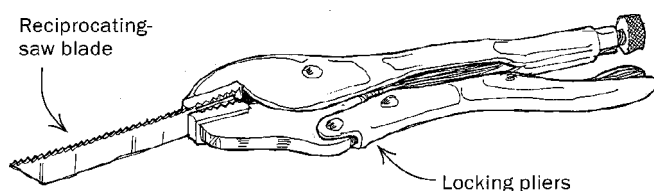

Need a saw that's useful in tight areas? Or a saw that can cut at odd angles? If so, simply choose the right reciprocating-saw blade to fit your needs and clamp it in the jaws of a pair of locking pliers, as shown above. You can create a wide array of specialized minisaws in minutes.

—R.B. Himes, Vienna, Ohio

Quick tip—To compress an oversized biscuit, fold a strip of paper over the biscuit and squeeze the paper and biscuit in a vise. This not only compresses the biscuit but might also remove some of the moisture that made it swell.

—Robert H. Gray, San Francisco

Jointing with sandpaper

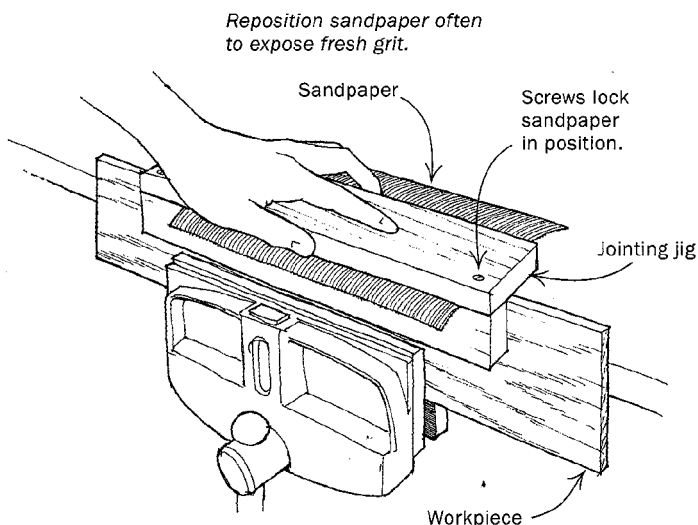

I designed the jig shown above for jointing edges when I was using thin, salvaged timber to be glued up into wide panels for cab-

inet doors. To get nearly perfect joints, I needed square, straight edges on the thin workpieces, and my cast-iron jack plane is too heavy and clumsy for such delicate work. The jointing jig I came up with is a bit slower than a plane, but the finished edges are square and smooth.

My experiments with this technique have produced two models. One model, shown in the sketch, is handheld and moved against the clamped workpiece like a plane. The other, which is very similar, mounts upside down in a bench vise, and the workpiece is moved against it. I use sheet sandpaper in the handheld model and a strip of abrasive sanding cloth (like the kind used in belt sanders) in the bench model. In both, as the sanding grit wears down, I loosen the screws and move the abrasive paper or cloth to place fresh grit in the sanding area.

—Anthony Clarke, Moonta Mines, Australia

Quick tip—Adjusting the blade guides on my bandsaw is easier now that I don't have to look for the necessary Alien wrench. I use a refrigerator magnet with a clip on it to hold the Alien wrench to the upper door of the bandsaw. I also have one on my tablesaw to hold the Alien wrench that adjusts the throat-plate leveling screws.

—Mike Schwarz, Atlanta, Ga.

Sharpening with a flying wedge

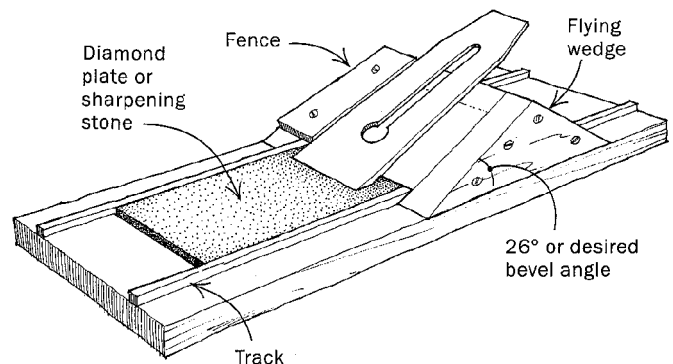

I was looking for a method to sharpen my plane irons that was quick, accurate and didn't remove too much metal. And I have an aversion to roller guides that are messy and push waste metal into the stone. I found the solution with this simple fixture.

Start with a hardwood board that is a couple of inches wider than your sharpening stone. Attach one track (made from a hardwood strip, $\frac{1}{4}$ in. square) about $\frac{3}{4}$ in. in and parallel to one edge of the board. Now place the stone against the track as it would be placed during use, and use it to mark where to attach the second track to the other edge.

Make the wedge specific to your own bevel-angle needs. The runners of the wedge must straddle both the stone and the tracks and slide freely without play. A little wax on the runners will help. To complete the fixture, attach a fence to the wedge so that the piece being sharpened will remain square to the stone. If you prefer to use two grades of stones, you can make the board long enough to hold both stones.

—Scott E. Davis, Schofield, Wis.

Methods of Work

EDITED AND DRAWN BY JIM RICHEY

Safer tablesaw switch

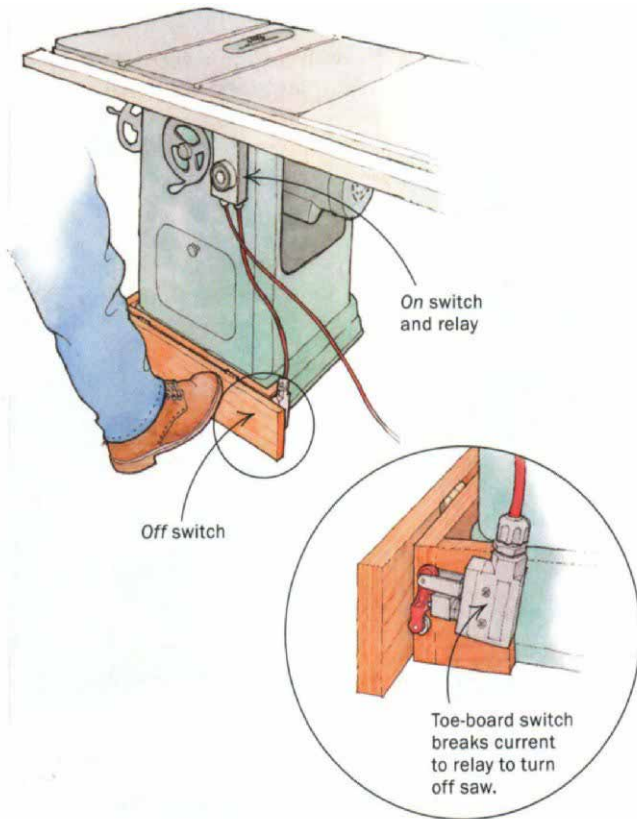

WIRING SCHEMATIC

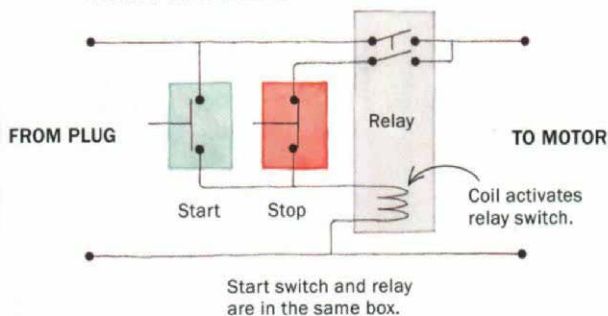

sawcut, this is not a problem. But when something goes wrong, you may be in trouble. I modified my tablesaw switch to solve that problem (see the drawing at left). I can turn off the saw without taking my hands off the workpiece or even looking away from the sawblade. The major improvement with this setup is that the *on* and *off* functions are at different locations. I turn on the saw with a push button in the conventional location. But to turn off the saw, I tap a toe-board switch along the base of the saw with my foot.

The components of this switching system include a momentary-contact single-pole, single-throw (SPST) normally open switch; a momentary-contact SPST normally closed switch; and a double-pole, single-throw (DPST) relay. The normally open SPST is mounted in the conventional position to turn on the relay. The normally closed SPST is mounted on the base of the saw where it is activated by the toe board to turn the relay off. The relay, which actually controls current to the saw motor, is mounted in a box with the *on* switch. A wiring schematic is shown below left. The relay is also called a motor contactor. The contacts must be rated to carry your saw's current—20 amps are usually enough, but you need to check the rating for your tablesaw motor. The coil voltage should be what is used on your saw—120 or 220 volts a.c. (When in doubt, ask a qualified electrician.) The switches and the relay are commonly available from electrical supply stores for less than \$15 each.

—Jamie Buxton, Redwood City, Calif.

Tensioned fairing board

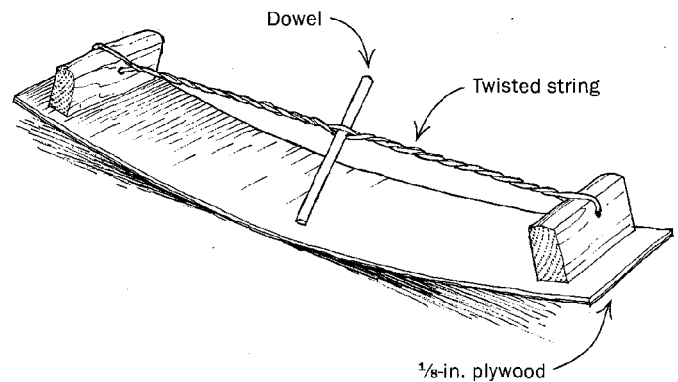

In my opinion, conventional tablesaw switches are a potential safety hazard for woodworkers. To turn off the saw, you must first take your attention off the blade (while it is spinning) and then remove your hand from the workpiece. If all goes well with your

While reading Lon Schleining's comments about using a fairing board to smooth the outside curve of a coopered door (*FWW* #135, p. 85), I was reminded of the fairing boards used in the boat-building industry to smooth boat hulls. With the simple addition of a string tensioner, you can use the same fairing boards to

A reward for the best tip

Jamie Buxton works as an electrical engineer by day and as an avid woodworker and volunteer for Habitat for Humanity in his spare time. He learned woodworking basics from his father, an academic who grew up on a Nebraska farm. Buxton has been building mostly furniture for family and friends over the past 30 years. His design for a tablesaw switch encourages safety by allowing the operator to keep both hands on a workpiece while turning off the saw. Send us your best tip, along with any photos or sketches (we'll redraw them) to *Methods of Work*, Fine Woodworking, P.O. Box 5506, Newtown, CT 06470-5506.

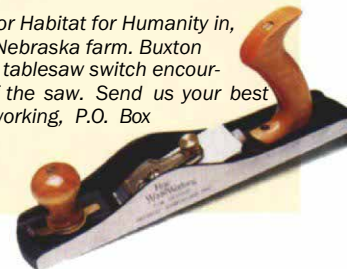

Methods of Work (continued)

smooth inside curves. Here's how. Make a fairing board from $\frac{1}{8}$ -in.-thick plywood. It should be $4\frac{1}{2}$ in. wide to fit self-stick sandpaper and about 18 in. long. Glue and screw handles to each end and countersink the screws. Drill a hole through each handle and attach a loop of string. By twisting and tightening the string with a dowel, the fairing board can be tensioned to the exact radius of the curve or a little more to keep the edges from digging in.

—Tom Jamieson, Belfast, Maine

Quick tip: Enlarging an existing hole with a Forstner bit or a spade bit is difficult because the bit will wander. To correct this problem, drill a hole through a piece of $\frac{1}{4}$ -in.-thick scrap and use double-stick tape to secure the scrap to the spot that you want to drill. The scrap will keep your bit from wandering.

—Jeff Vanek, Lansing, Ill.

Shopmade dovetail chisels

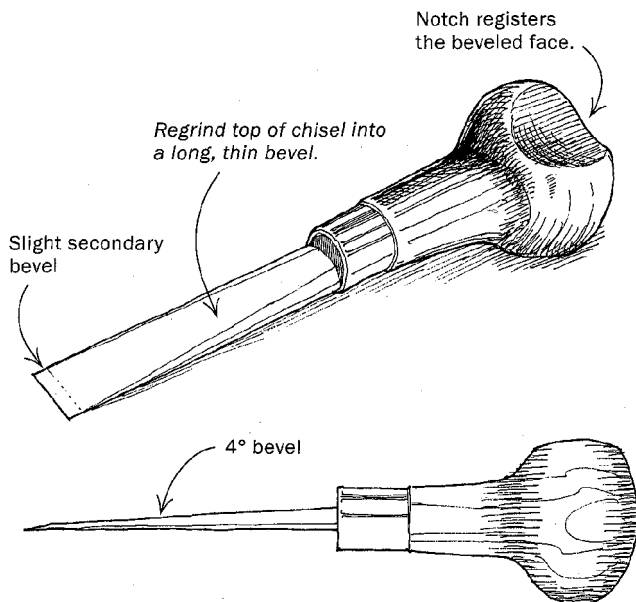

In studying the beautifully made dovetails in antiques, it looked as though the waste between tails had been removed by a single, slightly undercut, shearing cut to the center of the drawer side. To replicate whatever system the old-timers were using, I evolved the system that I now use, which is centered around a reground chisel with an extremely long, thin taper. Because the thin taper offers less resistance, you can drive it halfway into the workpiece in one step. This enables you to chop out the waste much faster and cleaner than you can with standard, flat-beveled chisels.

To modify a standard bench chisel, carefully regrind and lengthen the bevel of the chisel until it extends the entire length of the blade. On my chisel the bevel is about 3 in. long and makes a 4° angle. Add a very slight secondary bevel at the cutting edge to give the edge some strength. Although the long bevel does seem to make the edge quite delicate, in 20 years of use I have not chipped an edge so much that it required regrinding.

To use the modified chisel, hold it with the beveled side toward

you—I added a notch in the handle just for this purpose. Then make the first strike lightly with the chisel angled slightly away from you. Make all subsequent strikes at 90°. The chisel will have a tendency to angle toward you, which is normal and results in a slight undercut.

It should take you two to four strikes to drive the chisel to the center of the workpiece. Turn the piece over and repeat the procedure. The last strike will break the remaining wood fibers, and the waste will pop out.

I have two sizes of the reground chisels— $\frac{1}{2}$ in. and $\frac{1}{4}$ in.—which have served almost all of my dovetailing needs.

—Tom Zimmerman, Cambridgeport, Vt.

Quick tip : To create a pattern for a wood patch or inlay, press a piece of aluminum foil into the depression, and then gently run your finger around the outside edge of the depression to obtain an exact image. Use the pattern to trace the outline directly onto the wood you will be using as a patch. —R.B. Himes, Vienna, Ohio

Cardboard polishing wheels

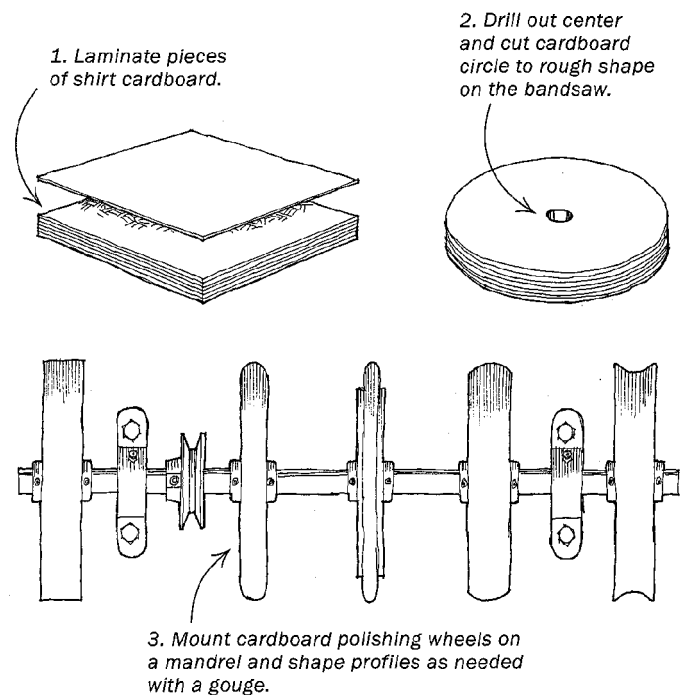

I put a sharp, polished edge on my tools with shopmade, laminated cardboard polishing wheels. The wheels are dense, long lasting, easy to customize and inexpensive to make.

To make a polishing wheel, use wallpaper paste to laminate shirt cardboard into a thick plank, $\frac{1}{4}$ in. to $\frac{3}{4}$ in. thick, depending upon your need. With a compass, mark the circumference of the wheel and the center. Rough the wheel round with a bandsaw or jigsaw. Drill a hole in the center, mount the rough wheel on a mandrel, or shaft, and true it to shape with a turner's gouge. Now is the time to customize the wheel's profile. If you need the edge convex or concave, cut it to suit. Be sure to wear goggles and a dust mask for this step because cutting the cardboard makes a lot of fine dust. If you

Methods of Work (continued)

do a lot of carving and need polishing wheels of varying radii, you may wish to mount five or six wheels of different profiles on a mandrel between two pillow blocks.

To use, load up the wheel with polishing compound and carefully press the tool against the wheel with the edge pointing in the same direction as the rotation. The polishing compound made for stainless steel is excellent for carbon steel as well.

—Peter LaMontagne, New Britain, Pa.

Rotated bench vise

Rotated vise increases throat depth.

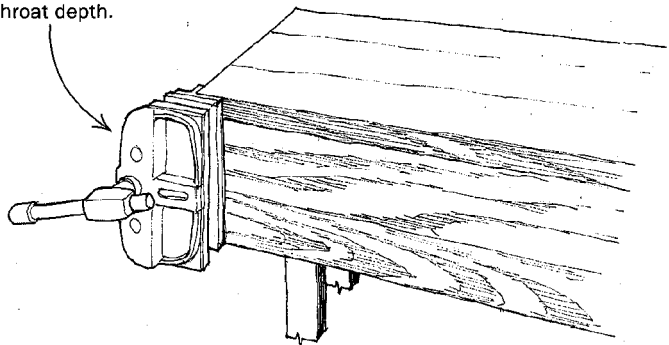

On my workbench I mounted one vise in the normal position and another vise rotated 90° to the first one. The second vise gives me an increased throat depth for holding longer stock vertically.

—Richard Griffin, Adrian, Mich.

Hanging cabinets with a French cleat

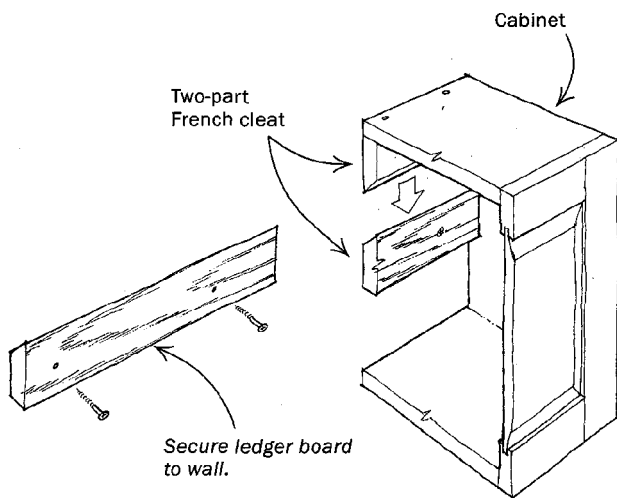

When hanging a mantle or a wall cabinet, I use a two-part French cleat that has several advantages. The system allows me to position the cabinet on the wall without regard to stud locations and also allows for later removal and replacement without serious

damage to the cabinet or wall. Another advantage is that the ledger board is much lighter in weight than the full cabinet, so it is easy for one person to level and secure it to the wall. To make the cleat, rip a clear piece of 1x6 hardwood down the middle at 45°. Attach one half of the cleat to the cabinet back as shown in the drawing below left. Carefully level and attach the other half to the wall to serve as a ledger board. Lift the cabinet onto the ledger board and push down on it for a snug fit.

—Jeff Tucker, Kill Devil Hills, N.C.

Router dado setup on a tablesaw

Auxiliary fence slips over regular fence.

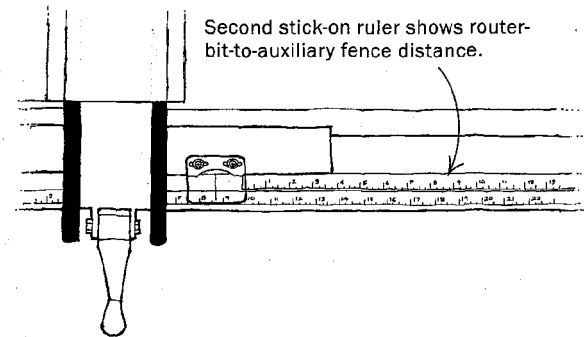
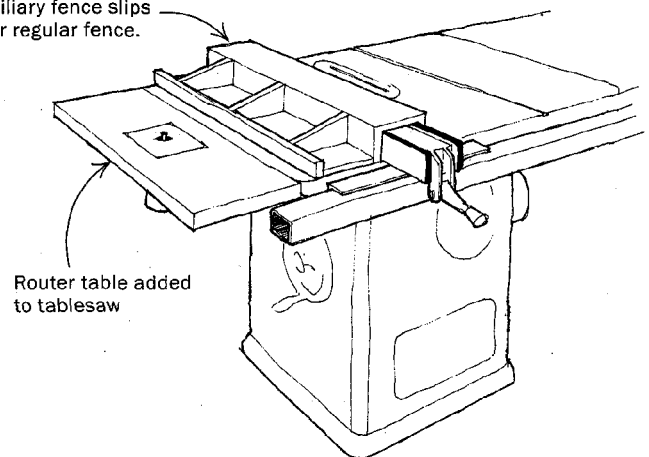

One way that the Biesemeyer and other similar tablesaw fences have changed the way we work is that the alignment guide is so accurate that you can make quick, confident fence setups by just glancing at the hairline rule. Here's how you can extend this accuracy for making dados.

Mount a 3-hp router under an extension table on the left-hand side of the tablesaw. Make an auxiliary rip fence out of plywood that slips over the saw's regular rip fence. The auxiliary fence extends the reach of the rip fence so that it can be moved right up to the router bit.

Next, mount a second stick-on measuring rule to the top of the front fence rail, carefully aligning the rule before mounting it in place so that the hairline on the alignment gauge shows the exact distance between your router bit and auxiliary fence. With this setup you can rip and dado plywood panels for cabinets in no time.

—Garret Brim, Harbor City, Calif.

Methods of Work

EDITED AND DRAWN BY JIM RICHEY

Center-finding jig for bandsaw

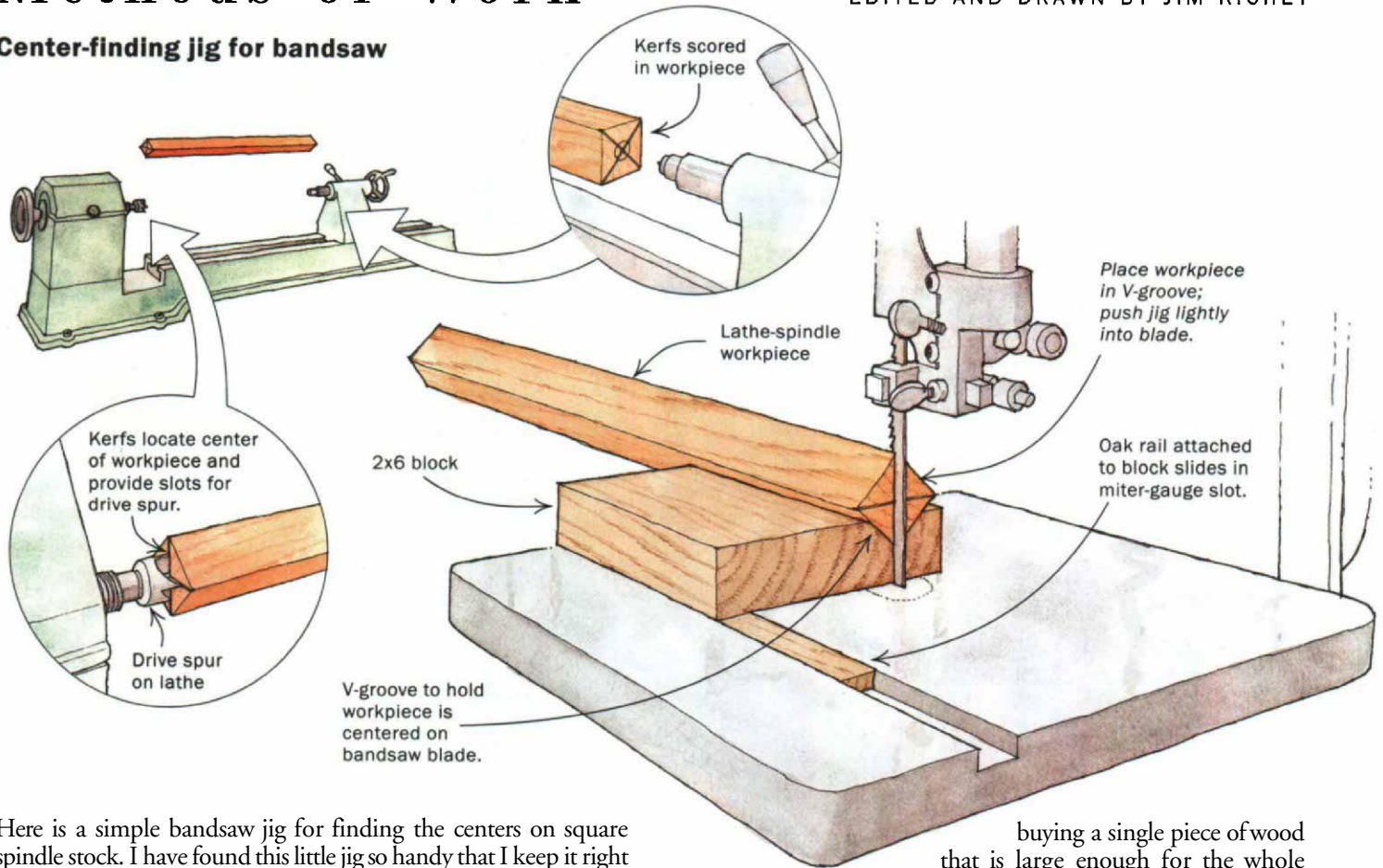

Here is a simple bandsaw jig for finding the centers on square spindle stock. I have found this little jig so handy that I keep it right next to my bandsaw for quick access.

The jig is pretty simple. It consists of an 8-in.-long block of 2x6 framing lumber with a 90° V-groove cut into the length of the block, as shown in the drawing above. I attached an oak rail to the underside of the block to slide in the bandsaw's miter-gauge slot, and I positioned the rail so that the V-groove is centered on the bandsaw blade.

Now when I need to turn a spindle on the lathe, I just place the workpiece in the jig and slide the jig lightly into the blade to saw a diagonal kerf across the end of the workpiece about $\frac{1}{16}$ in. deep. Then I rotate the workpiece 90° and make another shallow cut into the end. The resulting kerfs not only locate the center of the stock, but they also provide slots for the drive spur of the lathe to grip.

—Robert F. Reynolds, Columbia, Md.

Book-matching a small tabletop

Here's a technique I use to build a nightstand or an end table with a top and legs that are well-matched in color and grain. Start by

buying a single piece of wood that is large enough for the whole project. The board should be at least a full 2 in. thick and 6 in. wide. If possible, select a board that is flatsawn. The cutting sequence will give you a quartersawn tabletop.

Cut at least three billets out of the board. The first two are for the tabletop, and the third is for the legs. Make the top by ripping small boards from the two top billets and then gluing them together into a wide panel with book-matched ribbons. To facilitate reassembling the top, mark out the ends of the top billets as shown in the top left drawing on p. 20. The marks will help keep the book-matched pairs together and will show their cutting order from the edge of the billet. To make this process work, it is important that both billets be oriented in the same direction and ripped from the same edge.

The result will be a tabletop that is color matched and symmetrical, showing ribbons of book-matched grain. If there is a stripe of sapwood on the left, there will be one on the right side as well. As noted before, a flatsawn board yields a quartersawn top that will be very stable and—if it's oak—will have some enhanced figure. If

A reward for the best tip

Robert F. Reynolds won an engraved Lie-Nielsen handplane for sending this issue's winning tip. His jig (above) makes it easy to find and mark the centers for turning spindles quickly and accurately. Reynolds is retired from a distinguished career first in the U.S. Navy and then as an engineering specialist for the National Security Agency—a federal government department that's so secret its existence wasn't even publicly acknowledged for many years. Nowadays, he restores antiques and builds one-of-a-kind pieces of furniture in his large basement shop. Send us your best tip, along with any photos or sketches (we'll redraw them), to *Methods of Work*, Fine Woodworking, P.O. Box 5506, Newtown, CT 06470-5506.

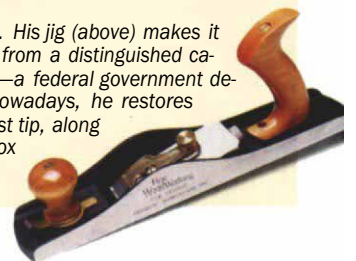

Methods of Work (continued)

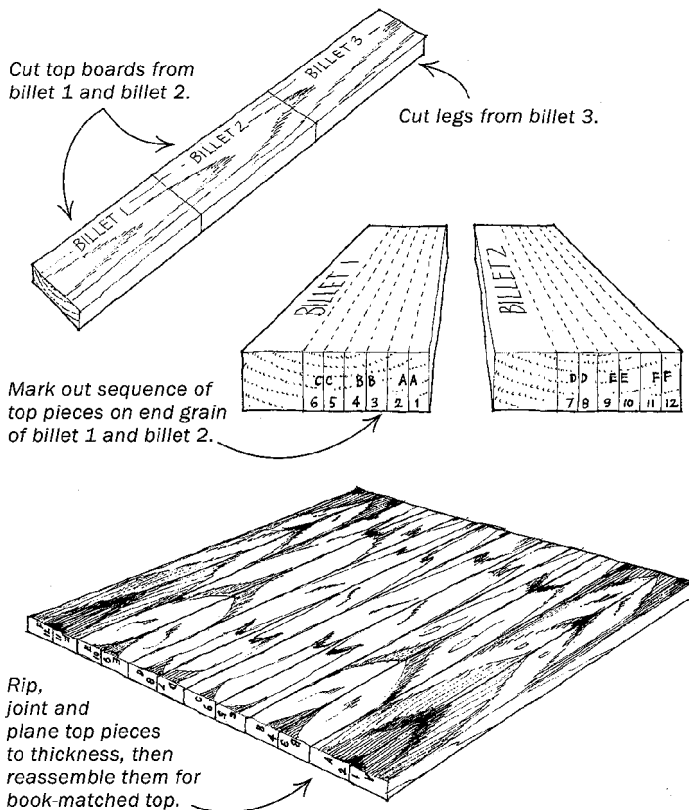

you don't use the entire width of the billets for the top, rip the remainder to yield boards for the skirt, drawers or other parts of the table. Before I rip the legs, I mark the end of that billet so I can face-match the legs as I wish.

—David Sobel, Tampa, Fla.

Deadening vibrations in a handplane

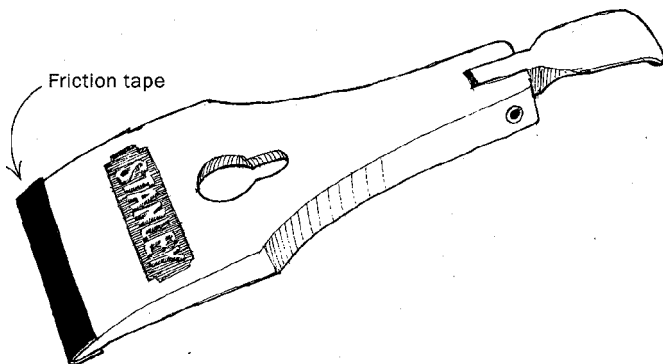

Inspired by Garrett Hack's handplane article (*FWW*#136, pp. 38-45), I set out to deaden the vibrations in the cutting iron of an old Stanley Bailey No. 4 that I had recently restored. I filed and honed the working edge of the lever cap dead flat. Then I folded a piece of friction tape over the nose of the lever cap. I adjusted the lever-cap screw so that the cap is tight but does not heavily compress the cutting iron. In action, the tape deadens the metallic vibrations

I used to get when cutting, resulting in a flatter, more even cut. The modified plane performs superbly.

—David Cancell, Millburn, N.J.

Adjustable dovetail marker

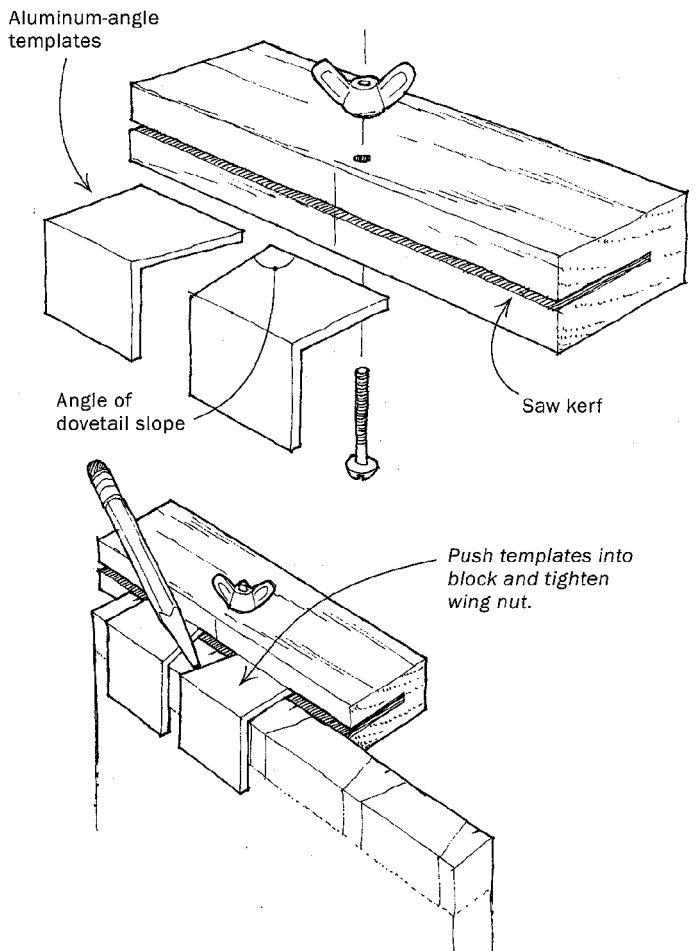

Here is a versatile dovetail marker that is simple to make. Start with a length of $1\frac{1}{4}$ -in. aluminum angle and cut two template pieces sloped at your preferred dovetail angle, one left, one right. Now take a block of wood, about 1 in. by 2 in. by 4 in., and saw a kerf in the block so that the two aluminum templates slide into the kerf tightly. Mark a centerline across the middle of the block and install a thin screw and a wing nut to lock the aluminum templates in place.

To use the marker, first mark a pencil line at the midpoint of each dovetail-pin location. Hook the marker over the board and push the templates in against the board. Set the templates equidistant from the centerline on the block to the size you want your pins to be and tighten the wing nut to lock the templates in place. Move down the board, marking out pins, both top and front.

If you prefer to mark tails first, simply put the templates in the other way.

—Zvi Rotem, Kiriat-Tivon, Israel

Quick tip: If you have a Biesemeyer fence on your tablesaw, try reversing the mounting position of the cam lever that locks the

Methods of Work (continued)

fence in place. Gravity keeps the lever unlocked, which makes it easier to move the fence with one hand.

—*Kim Newcomb, Lafayette, Calif.*

Bandsaw circle-cutting fixture

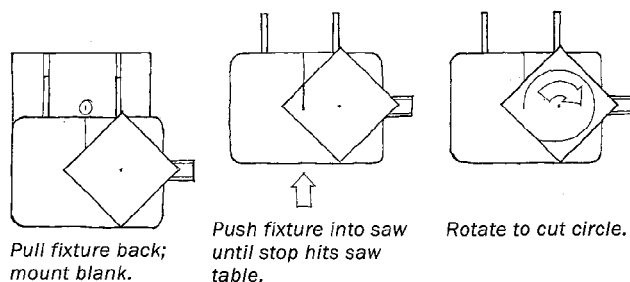
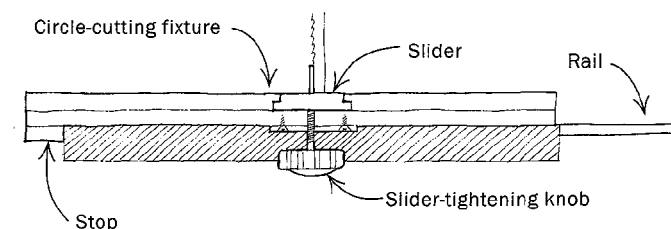
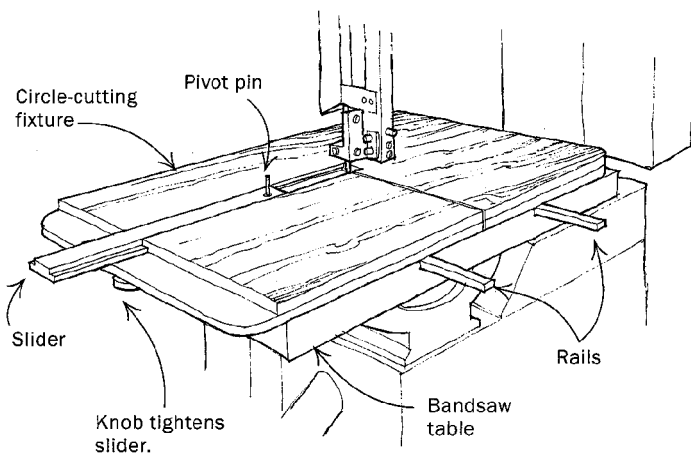

While I make no claims for reinventing the wheel, this bandsaw circle-cutting fixture has a few extra features that make it accurate, reliable and a pleasure to use.

The fixture consists of a base and a slider. The base is laminated from two pieces of $\frac{3}{4}$ -in.-thick plywood. Size the plywood so that the base will extend a few inches beyond the right side of the saw table. Before laminating the two pieces, rout a stepped slot in the top piece so that when the two pieces are glued together the slot forms a T-shaped channel for the slider.

Attach one or two rails to the bottom of the base to slide in the miter-gauge tracks of the bandsaw table. Attach a plywood stop under the front of the base so that it bumps against the table when the bandsaw blade is even with the pivot pin. Also, install a thread-

ed knob under the base to lock the slider in position. The slider is simply a length of hardwood milled to fit the T-shaped slot in the base. Install a $\frac{1}{4}$ -in.-dia. steel rod near one end of the slider to serve as the pivot pin.

To use the fixture, adjust the slider for the correct radius. (Note that the slider can be turned around to make larger circles.) Drill a $\frac{1}{4}$ -in.-dia. hole in the center of the circle blank and place the blank on the pivot pin. Pull the base back, turn on the saw, then gently push the base into the blade until the base hits the stop. Rotate the blank to cut the circle. When that's done, gently back the fixture out of the blade using the entry cut.

—*George W. Sibbald, Rochelle Park, N.J.*

Quick tip: To reduce the pesky static cling that causes wood chips to clog the discharge chute of jointers and other machines, simply wipe down the discharge chute with a fabric-softener sheet. The static cling is gone. Wiping with a fabric-softener sheet also keeps dust from clinging to plastic safety glasses and face shields.

—*Matthew C. Jackson, Rapid City, S.D.*

Tabletop attachment slots

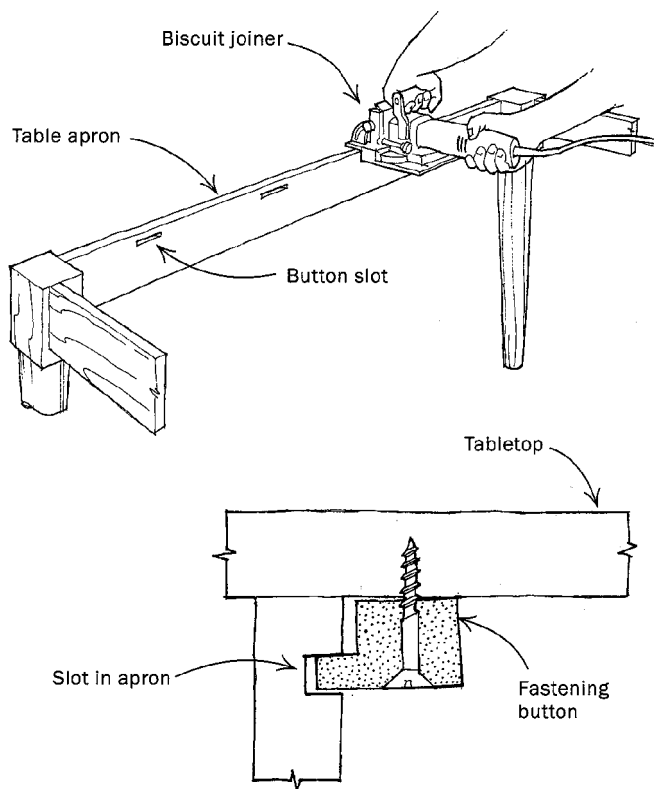

While building a small table, I had the idea of using my biscuit joiner to cut the slots in the apron for attaching the top with small, L-shaped buttons. I discovered that the approach held several advantages over routing the slots or chiseling them by hand. First, it is easier to set the proper distance of the slot from the top by setting the joiner's fence. And it is easier to adjust the width of the slot by simply lowering or raising the fence after cutting the first

Methods of Work (continued)

slot. Finally, each slot has rounded ends that enable you to turn the button into position easily.

—*Ian Welford, North Yorkshire, United Kingdom*

Using foil tape to locate lock mortises

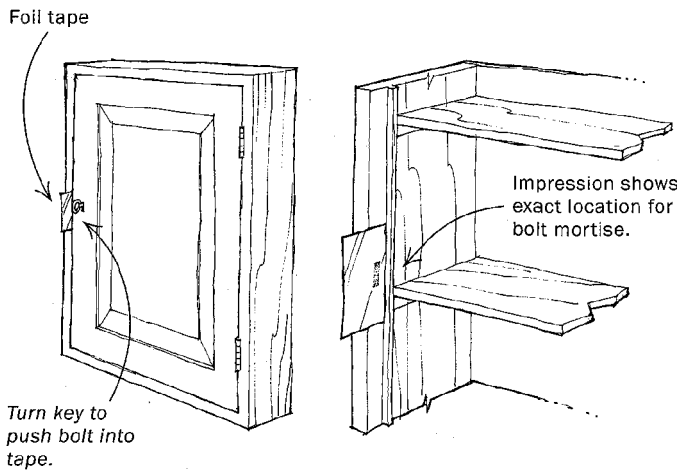

Here's how I use aluminum-foil tape to find the exact bolt location for a drawer, box or cabinet door lock. Stick a piece of the foil tape close to where the bolt will make contact. Then insert the drawer with lock in place and turn the key in the lock with a little extra pressure so that the bolt presses against the foil. The bolt will leave an imprint in the foil in the exact location where the mortise should be. Mark through the foil with an awl at the corners of the impression to transfer the mortise location to the wood. Foil tape is used in the heating and air-conditioning trade to seal sheet-metal ducts and can be found at most building-product centers.

—*Dennis Kuchenbecker, Chippewa Falls, Wis.*

Slotted angle plates in the woodshop

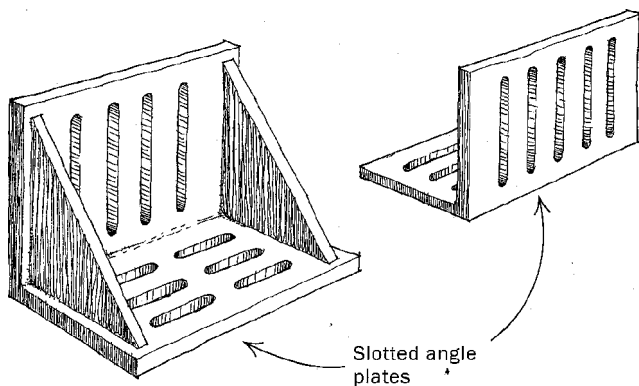

Tablesaw tenoning jigs and many other woodworking fixtures require two faces to be at a precise 90° angle to each other. In the past, I have spent a great deal of time fussing with wooden fixtures or filing aluminum angles to get a precise 90° angle. While brows-

ing at a local machine-tool supply shop, I stumbled upon an item called a slotted angle plate. This fixture is used in the metalworking trades for various applications. Angle plates come in a variety of sizes, are relatively cheap and have milled slots for attaching wood faces, if needed. They are accurate to fractions of a degree—well beyond the needs of any woodworker.

—*Andrew J. Lenhart, Royal Oak, Mich.*

Dust collection under the floor

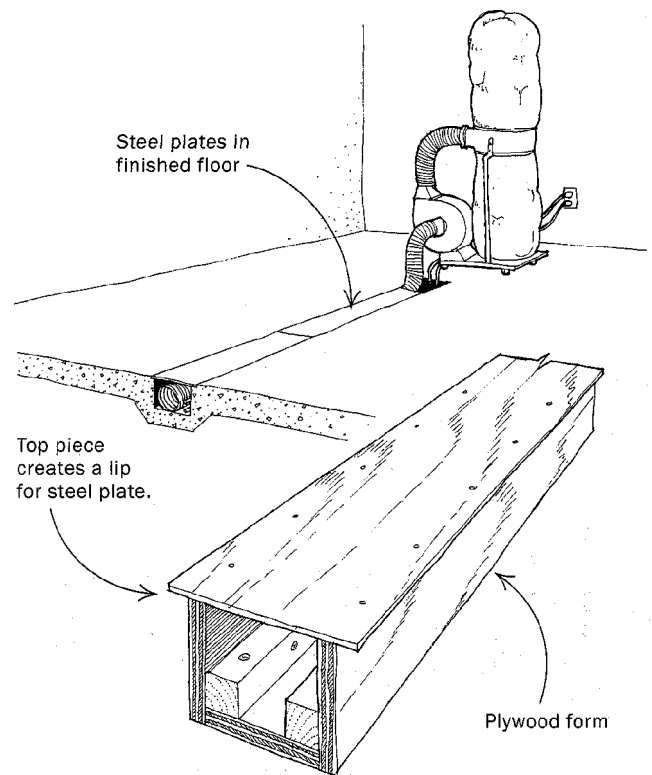

When I built my new shop, one major concern I had was how to run a dust-collection duct and power cord to my tablesaw. I wanted the tablesaw in the middle of my shop for convenience, but I didn't want electric lines or sheet-metal ducts hanging down from the ceiling or cluttering the floor. Also, I was uncomfortable about permanently embedding an air duct in the concrete floor.

After much thought, I came up with an idea that has worked out well. Before the floor slab was poured, I built a 5-in.-deep, 6-in.-wide plywood form to place in the floor where I wanted to run a channel. I capped the form with a piece of plywood that would create a lip at the top of the concrete channel. I assembled the form with easily accessible screws, so that I could disassemble it from the top after the concrete cured. I then placed the form into the floor and poured the concrete around it.

After the concrete had cured, I removed the form and had a perfect channel in which to run a 4-in. vacuum duct and a couple of extension cords to the middle of the shop floor. I topped off the channel with steel plates that fit neatly into the lip left by the form.

—*Bob Chandler, Rathdrum, Idaho*

Methods of Work

EDITED AND DRAWN BY JIM RICHEY

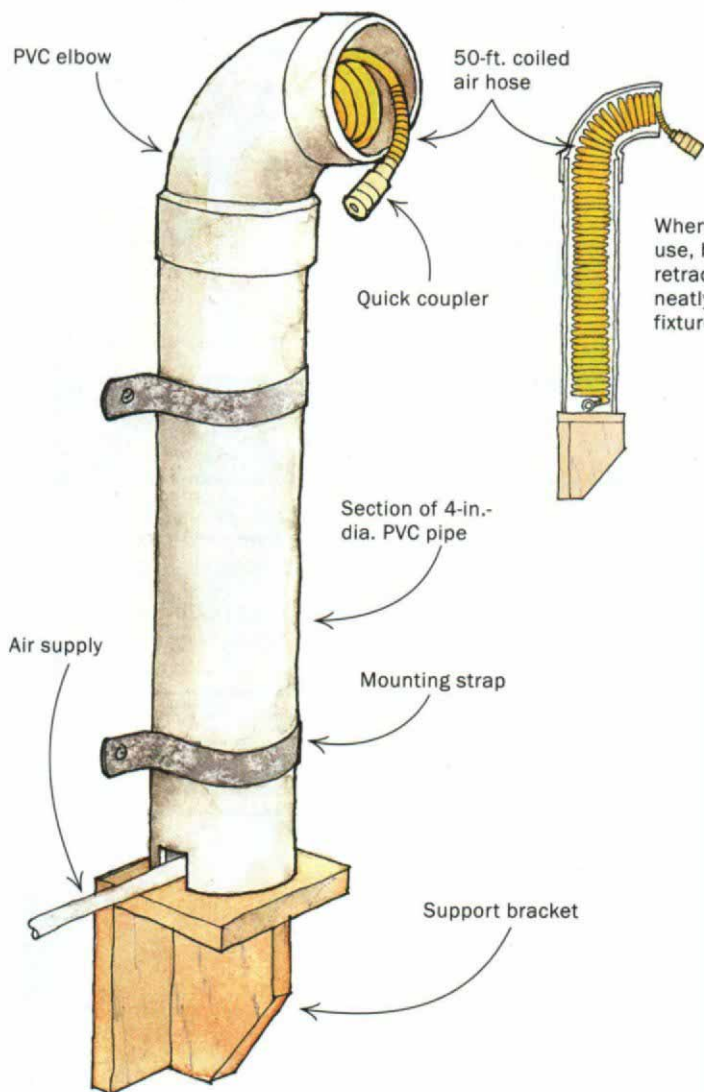

When not in use, hose retracts neatly into fixture.

Coiled air hose extends to work location.

To make the fixture, buy a coiled air hose, a section of straight 4-in.-dia. PVC pipe and a matching elbow. Glue up a length of the straight pipe to the elbow so that the total length of the pipe plus the elbow is a couple of inches shorter than the coiled air hose. Drill a hole or notch the pipe at the bottom to receive the air supply. Support the pipe with a bracket at the bottom and a couple of mounting straps wrapped around the straight section.

—Ed Grant, Ulster, Pa.

Jewelry-box clamps

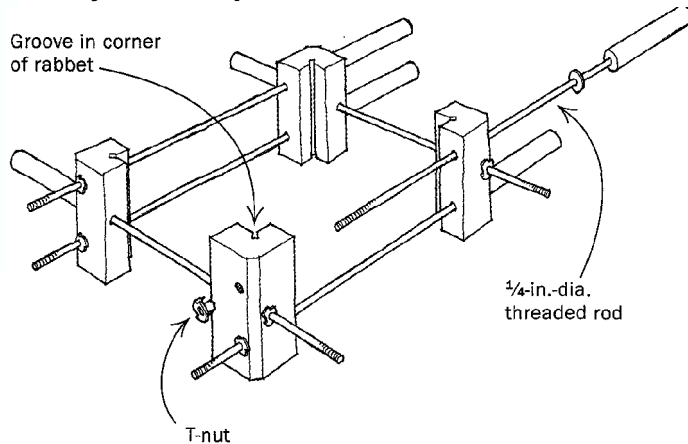

The inexpensive but effective homemade clamps shown above are designed for gluing up small jewelry boxes, 8 in. to 10 in. on a side. Start by cutting four 4-in. blocks from 1 3/4-in. square stock. Cut

Retractable air-hose fixture

You need a readily available air supply in your shop if you use air-powered tools. An air hose that snakes across the floor or over benches and machines is an awkward nuisance and can be a real safety hazard. Shown above is an inexpensive PVC-pipe fixture that puts your air supply right where you need it. A 50-ft. coiled hose has a reach of about 25 ft., and the hose retracts into storage when you're finished with it. The fixture can be attached to a wall, a post or under a bench.

A reward for the best tip

Ed Grant won an engraved Lie-Nielsen handplane for the winning tip shown above. His idea is a practical and inexpensive solution that brings order to the chaos that air hoses can sometimes cause in a woodshop. Grant is retired and lives on a small farm in northeastern Pennsylvania, where he accomplishes most of his woodworking in the winter months. He learned woodworking from his father and passed on the passion to both of his sons. Send us your best tip, along with any photos or sketches (we'll redraw them), to *Methods of Work*, Fine Woodworking, P.O. Box 5506, Newtown, CT 06470-5506.

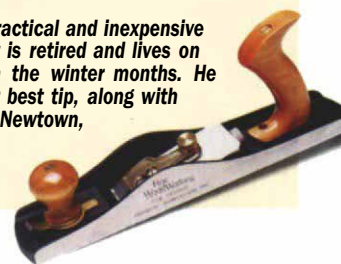

Methods of Work (continued)

a rabbet in one corner of each block to fit over the corners of the box, and cut a groove into the corner of the rabbet so that it doesn't interfere with the edge of the miter joint.

Cut six lengths of 1/4-in.-dia. threaded rod and, using epoxy, glue 1-in. dowel handles on one end of each rod. Drill three holes in each block with a 3/32-in. bit, install T-nuts and assemble the clamps as shown in the sketch. —*Jose L. Martinez, Niceville, Fla.*

Quick tip: An old computer mouse pad on the workbench will dampen the vibration from a sander and keep it from skittering across the bench when you set it down. You can also cut small pieces from a pad to use as protective, nonskid feet for finished projects. —*Jim Van Dreese, Wisconsin Rapids, Wis.*

A faster way to make half-blind dovetails

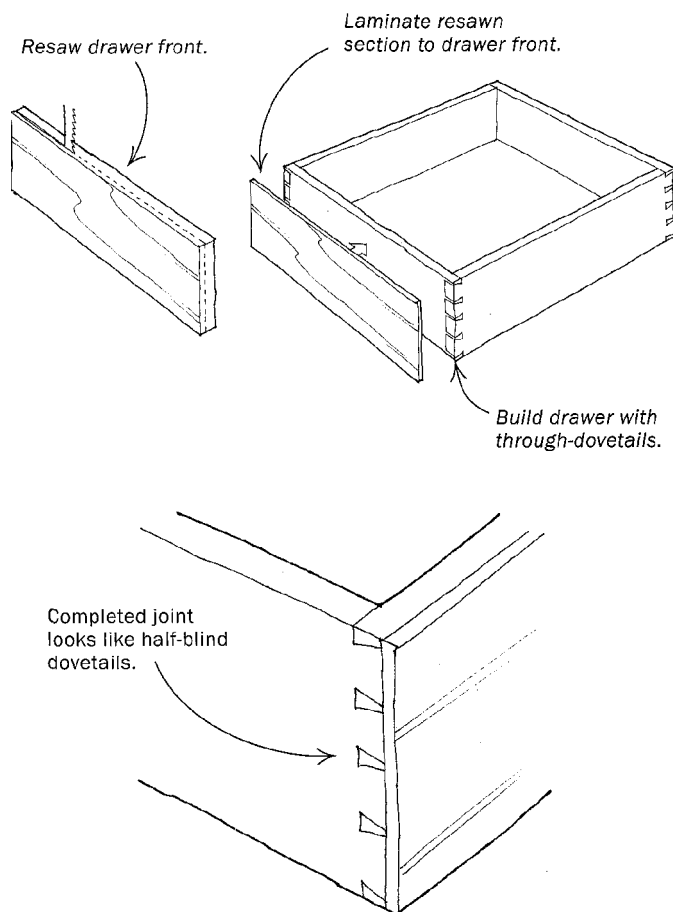

I was fortunate to learn how to cut dovetails from one of the best in the craft. In 1987, I spent two weeks as Alan Peter's assistant at the Anderson Ranch Arts Center. After all of that training, I can cut a set of through-dovetails as fast as I can set up a router jig.

But cutting half-blind dovetails is another story. Although there are some tricks to speed up the process using a router, removing the bulk of the waste from between the pins is mostly a slow and tedious process using a chisel. My solution is to start with a thick drawer front and rip a fat, 1/8-in.-thick slab off the front (see

the drawing below left). I do this while the drawer front is still oversized in width and length. Then I plane both pieces and set aside the 1/8-in. piece. After that, I cut regular through-dovetails—front and back—and assemble the through-dovetailed drawer. Once the drawer is together, I simply laminate the 1/8-in.-thick piece back onto the drawer front. After trimming the front piece flush on all four sides, I have (from all appearances) a set of perfect half-blind dovetails.

Another advantage of this approach is that I can rip a set of drawer fronts in sequential order from one thick board, resulting in a nicely matched flitch pattern on the fronts of all of the drawers.

—*Rob Cosman, Grand Bay, N.B., Canada*

Making duplicates on a disc or spindle sander

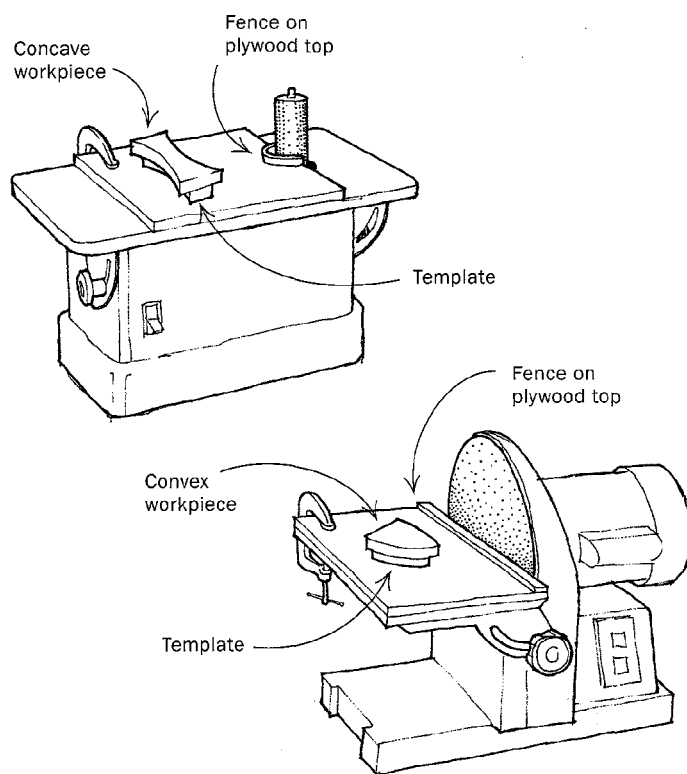

Here is a simple way to duplicate curved pieces using a template and a disc or spindle sander. This technique is useful when tearout is a problem or when extra-thick workpieces make template-routing impractical.

The key to this technique is clamping a scrap of plywood over the metal tabletop of your sanding machine and then securing a fence for the template to the plywood. Make the sanding template any convenient size smaller than the workpiece and adjust the fence forward or back to make the final size of the workpiece larger or smaller. Convex shapes can be sanded entirely on the disc sander. Concave shapes require a similar setup on a spindle sander. —*Gregg Roos, San Francisco, Calif.*

Quick tip—When I wanted to build a router table, I checked out the phenolic and acrylic inserts in the mail-order catalogs and decided they were too expensive. Then I came up with the idea to use a

Methods of Work (continued)

plastic cutting board, the kind found at any store that sells cooking utensils. The board machined well and cost less than \$5.

—Rick Grinstead, Charlotte, N.C.

Auxiliary vise jaws for portable workbench

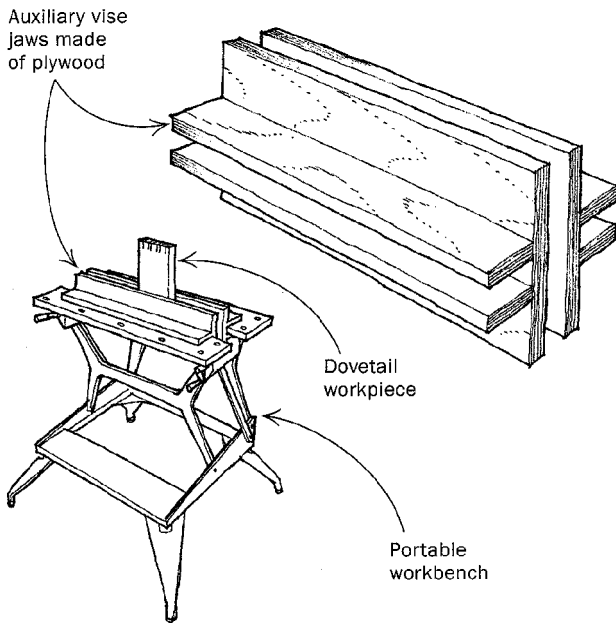

I like to saw dovetails by hand, but it's difficult without the proper vise. Before I equipped my shop with a good bench vise, I made these auxiliary plywood jaws for my portable bench—a setup that enabled me to get by fairly well. The jaws fit snugly over the regular jaws and hold vertical workpieces securely.

—Bob Key, Snellville, Ga.

Wrench for air-compressor drain valve

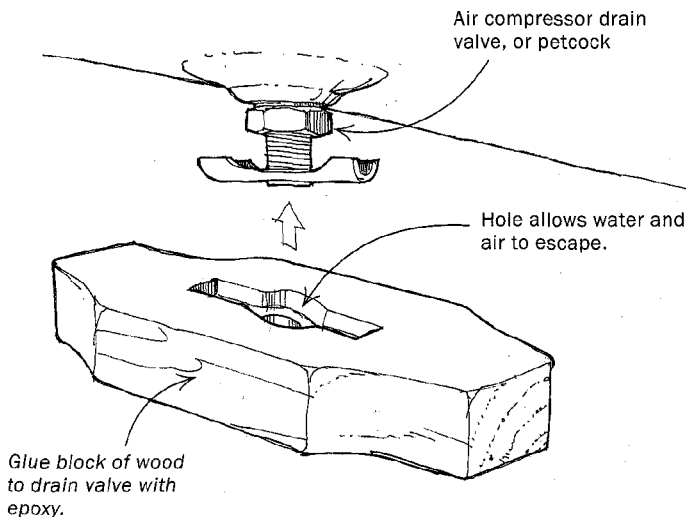

I know it is important to drain water from my compressor often to prevent rust in the tank. But the ditty little drain valve, or petcock,

mounted on the underside of the tank is difficult to use. So I solved the problem by making a new wrench. I routed a channel in a hardwood block to fit the valve and drilled a hole through the block to let air and water escape. I then shaped the outer edges to make the wood wrench easy to hold and glued it onto the valve with epoxy.

—John Weidner, San Francisco, Calif.

Bandsaw dovetail fixture

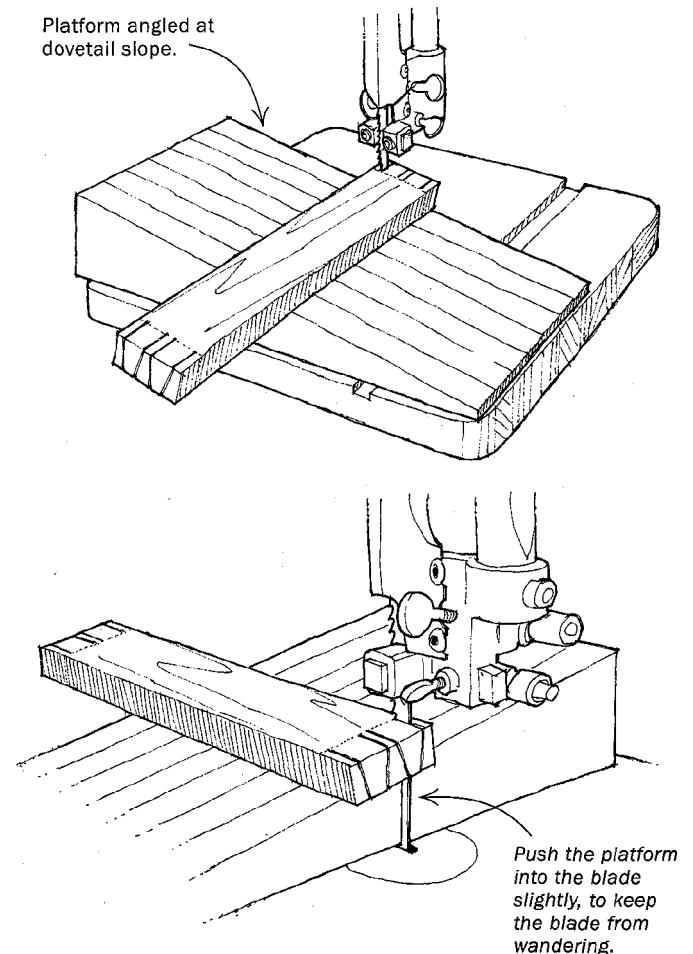

To cut dovetail joints, I start with the pins, cutting everything on my bandsaw. One problem that I ran into was that the table on my bandsaw—like that on most bandsaws—tilts in only one direction, limiting me to cut only one side of the pins. To overcome this problem, I built a small platform of laminated plywood that is angled at the correct dovetail slope.

I simply place the platform in front of the bandsaw blade, pushing it into the blade slightly to keep the blade from wandering. I cut one side of all of the pins, flip the platform around and cut the other sides. I then remove the waste with a chisel, mark the tails from the pins and saw the tails on the regular bandsaw table. This approach results in quick and accurate dovetails.

If you like to use different dovetail angles in different woods, just build two platforms—one for softwood and one for hardwood.

—Bruce Petersen, Canby, Ore.

Methods of Work

EDITED AND DRAWN BY JIM RICHEY

Spray-finishing small parts

Holding small parts while you spray-finish them can be a problem. Air pressure from the spray gun blows the parts around. And finish blowing back from the surface the parts sit on can create unexpected runs.

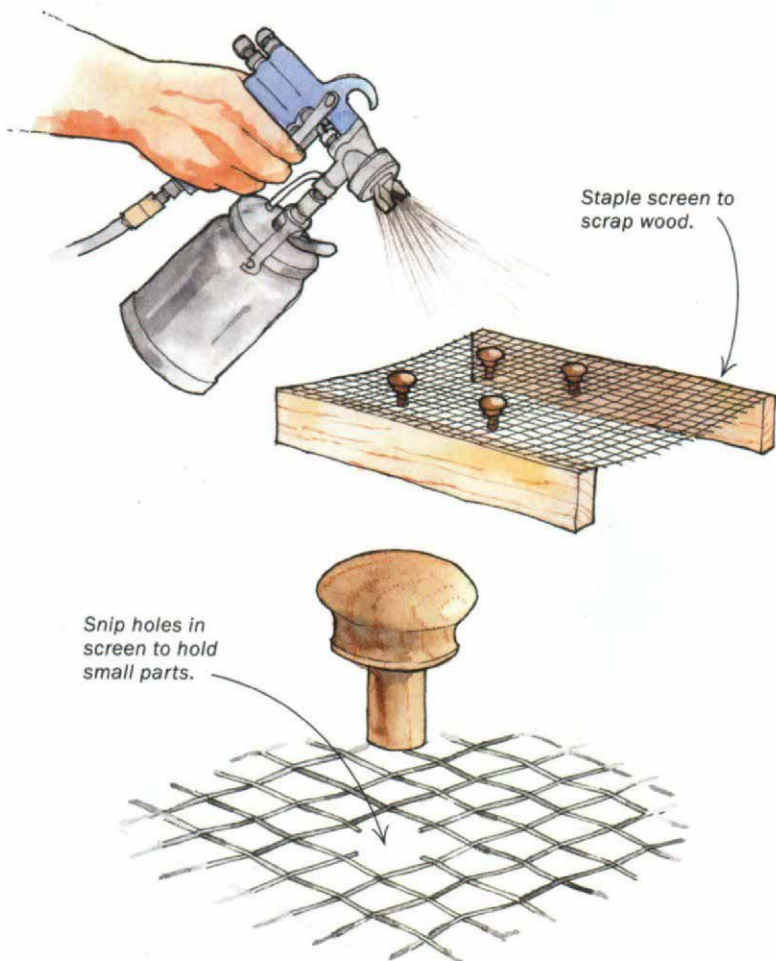

A simple solution is to hold small parts with common hardware cloth or hail screen, as it's sometimes called. Cut a suitable piece of the screen and staple it to scraps of wood to produce a stable base. Then simply place items to be finished on the screen and spray (see the drawings above). If you want to make sure the small parts don't move, snip out small sections of the screen to create wire fingers to grip each item. Because of the open nature of the screen, you won't have any problems with finish blowing back.

—R.B. Himes, Vienna, Ohio

Honing boards

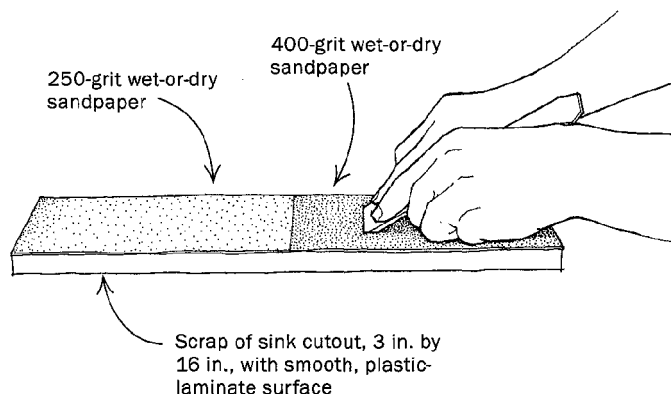

I've sharpened tools for years with these emery-paper honing boards. I prefer them over oilstones or waterstones because they put a finished edge on tools faster than stones, the working surface is bigger and they are neater and cleaner to work with, requiring no messy oil. Also, they cost only pennies to make.

Start by getting a sink cutout from a countertop fabricator. I buy these for about a buck apiece. Sometimes they're free for the asking. Pick a cutout with a smooth, plastic-laminate surface. Slice the cutout into strips 3 in. wide by 16 in. long. Then cut 3-in.-wide, 8-in.-long strips of 250-grit and 400-grit emery paper. Glue the paper end-to-end to the laminated side of the cutout scraps with contact cement. The combination of the two grits will give you a fast-cutting surface for shaping and a fine surface for honing. Two sheets of emery paper will cover four honing boards, so make up several while you're at it.

The honing boards will last for months or years, depending on how often you use them. But when the grit gets too worn to renew an edge quickly, just throw the board away and start with a new one. These honing boards also are great in the kitchen for sharpening cutlery.

—Tim Hanson, Indianapolis, Ind.

Jig for hand-chopping dovetails

This jig puts your chisel exactly where you want it when chopping dovetails (see the top left drawing on p. 18). It guarantees that shoulder lines will be perfect on both sides of the pins and tails and will be consistent from one workpiece to another.

The jig consists of a 3/4-in.-thick wood or plywood base, two side fences, an adjustable stop and a hold-down. Cut the side fences from 3/8-in.-thick stock or stock that is thinner than any lumber you will be working. One pair of wing nuts tightens the hold-down

A reward for the best tip

R.B. Himes won an engraved Lie-Nielsen handplane for his tip on how to finish small parts (above). Himes, a graphic artist by trade, is also a prolific tipster. Between *Fine Woodworking* and our sister publications *Fine Homebuilding* and *Fine Gardening*, Taunton has published more than two dozen of his ideas. Most of them were inspired, as he said, "from working on a shoestring." Send us your best tip, along with any photos or sketches (we'll redraw them) to *Methods of Work*, *Fine Woodworking*, P.O. Box 5506, Newtown, CT 06470-5506.

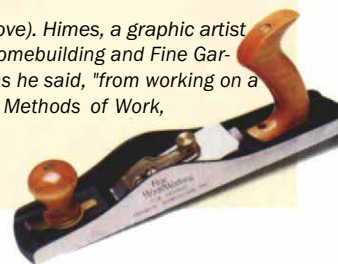

Methods of Work (continued)

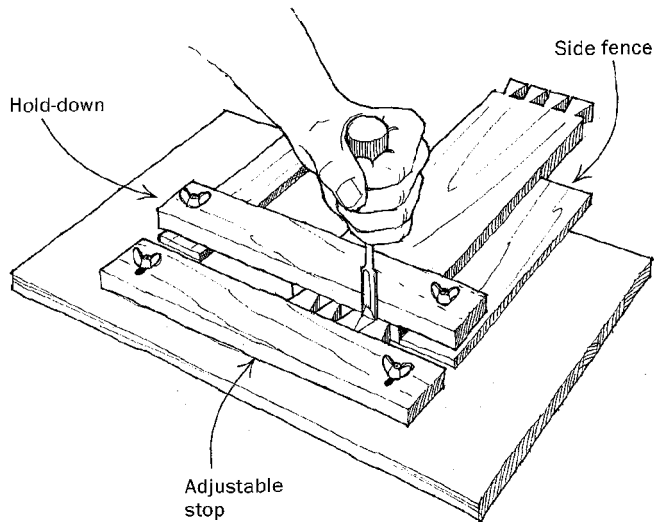

onto the workpiece, and another pair of wing nuts, fit over slots, allows adjustment of the stop.

To use the jig, adjust the stop so that the shoulder line of the pins or tails is directly under the edge of the hold-down. Insert the dovetail workpiece by sliding it against one of the side fences, then tighten the hold-down in place. Once the workpiece is secured, hold the chisel against the edge of the hold-down, where it is registered at a perfect 90°, and chop down halfway through the waste. Flip the workpiece to complete the other side.

—*Jacque L. Dupuy, Ft. Leavenworth, Kan.*

Chisel handle for paring mortises

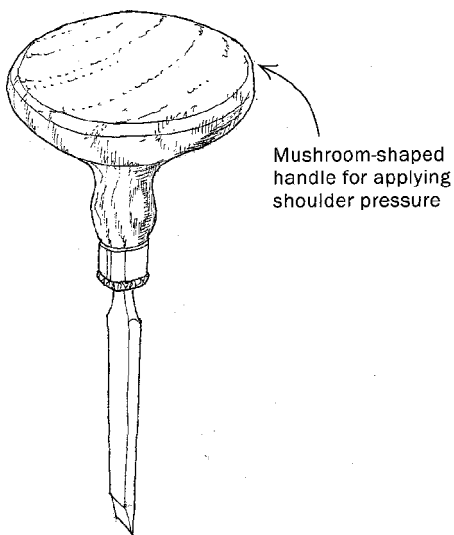

Joining furniture with mortise-and-tenon joints can be a problem if you don't have a mortiser to cut square holes. You must either square up the mortises with a chisel or round the tenons with a rasp. I square up, and I've found that the best way to do this is to guide the chisel with my hands while applying pressure to the back of the chisel with my shoulder. But after spending an entire

day squaring up more than 100 mortises, I had a sorely bruised shoulder from pushing the chisel.

So I dismantled the chisel and made a new handle with a mushroom-shaped end, similar to an old-fashioned hand drill. (I used a nice piece of boxwood that I had never found a good use for.) It works fine now: Pushing the chisel with my shoulder doesn't give me a pain.

—*Rudi Wolf, Les Plantiers, France*

Removable shoulder vise

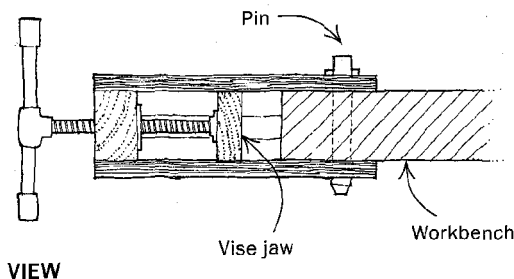
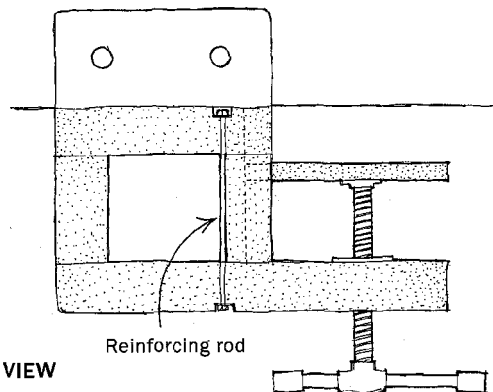
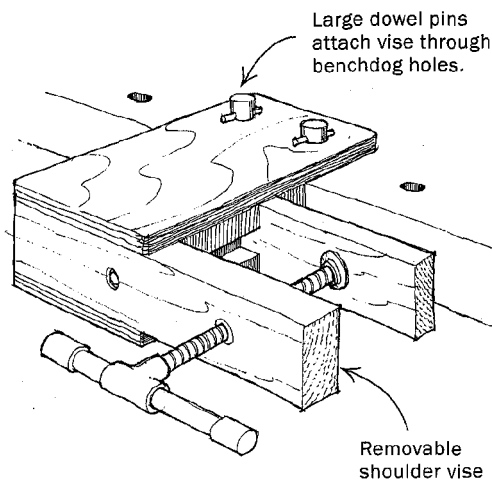

To fit the type of work I do, I designed my workbench around a permanently installed front vise and tail vise. However, I thought it would also be nice to have a shoulder vise for occasional light-duty use. So I came up with a removable design that anchors into the existing benchdog holes (see the drawings above). Use a

Methods of Work (continued)

tough wood for the pins that secure the shoulder vise to the bench because they take lots of strain. It is also important that the top and bottom pieces of plywood straddle the benchtop with no play.

—Louis Michaud, Rimouski, Que., Canada

Quick tip: When I added a thin layer of hot glue on the bottom of a bench leg to level it on an uneven ceramic floor, I discovered a second benefit: It kept the bench from sliding around.

—Marty Schlosser, Nepean, Ont., Canada

Reverse-profile sanding block for moldings

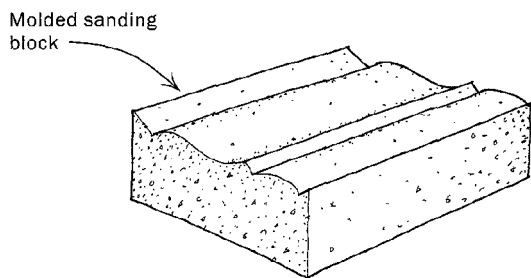
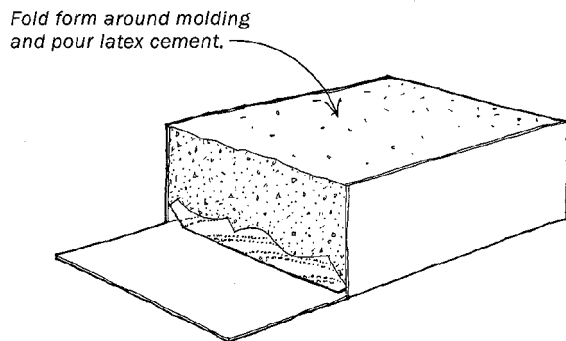
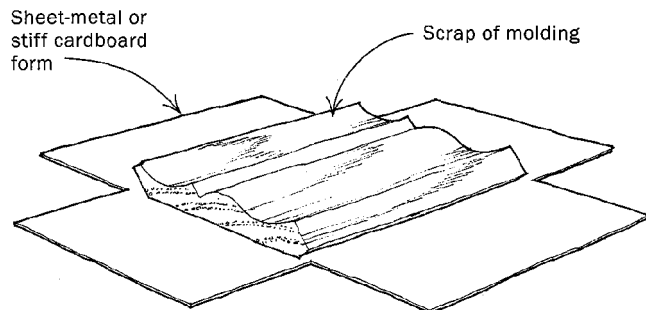

I use latex patching cement to make reverse-profile blocks for sanding moldings. The material costs much less and is easier to work than two-part epoxy compounds and auto-body fillers. Also, it's strong, and it molds easily to the profile of the molding.

To make a sanding block, cut a short length of molding to use as the form bottom. Coat the surface of the molding with wax so that it will separate easily from the patching cement. Make a sheet-metal or stiff cardboard box as shown above to act as a form for

the molding and the patching cement. Mix up a batch of the latex patching cement, using as little water as possible. Press the cement into the form around the molding and then cover with plastic wrap to slow evaporation. After the cement hardens, separate it from the molding and cure it in a plastic bag for a few days to maximize its strength and durability. To use the sanding block, simply wrap a piece of sandpaper around the profile side of the block and start sanding—the paper will conform to the shape of the block.

—Jay Li, Chesterfield, Mo.

Dial caliper monitors planer settings

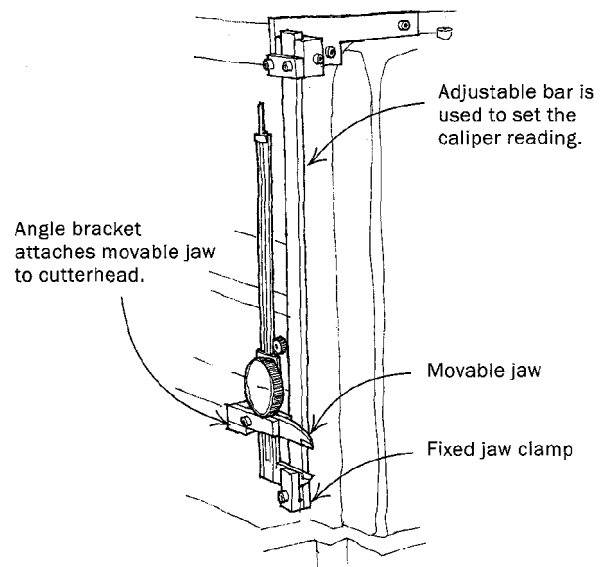
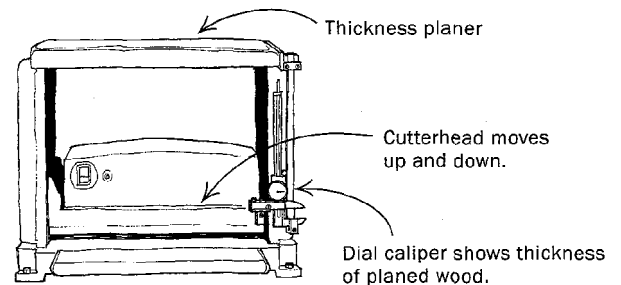

Most planers have only a crude pointer-and-ruler thickness indicator that is hard to read and approximate at best. I found myself measuring the thickness with a dial caliper after every pass, creeping up on the thickness I wanted. Finally, I decided to attach a dial caliper directly to the planer so that I could quickly read out the exact thickness to be planed beforehand.

To accomplish this, I attached the movable jaw of the caliper to the cutterhead with an angle bracket. I then clamped the fixed jaw of the caliper to a bar that is connected to the top of the planer frame. The bar can be moved up and down and then locked to adjust the caliper's reading. As I raise or lower the cutterhead, it moves the jaw of the caliper to change the reading on the dial.

—Stan Kessler, Fort Wayne, Ind.

Methods of Work

EDITED AND DRAWN BY JIM RICHEY

Shopmade steady rest

In the process of turning dozens of spindles for a bed I was making, I found I needed a steady rest to stabilize the thin spindles during the later stages of turning. I came up with a design that is easy

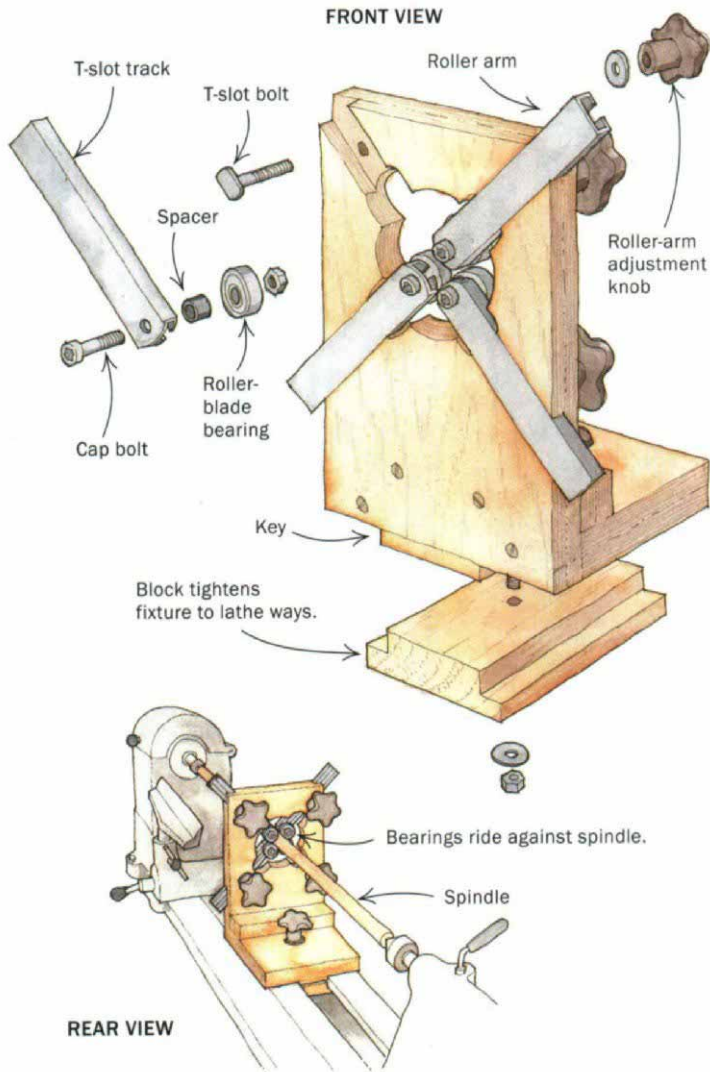

track. The roller arms adjust and lock into position with T-slot bolts and plastic knobs. T-slot hardware is available from Woodcraft (800-225-1153) and other mail-order suppliers.

To make the steady rest, start by cutting out the vertical part of the body from the Baltic-birch plywood and locating the lathe's centerline on it. You can find and mark the centerline's height above the lathe bed by placing the vertical piece on the lathe bed and squeezing it between pointed centers. Cut two dados into the vertical part of the body (for the T-slot tracks) in an X pattern, with the X centered over the centerline point. Cut a circular opening through the body that is big enough for the largest spindle you will be turning, then drill holes for the hardware as necessary. Add a key to the bottom of the body to keep it centered and straight on the bed of the lathe. You will need to tailor the key and the fixture's bed-locking mechanism to your lathe.

To use the steady rest, slide it onto the spindle, lock the fixture to the bed, then adjust the roller arms so that the bearings ride gently against the spindle and support it during turning.

—Robert D. Eberhardt, Eau Claire, Wis.

Stabilizing the legs of a wobbly chair

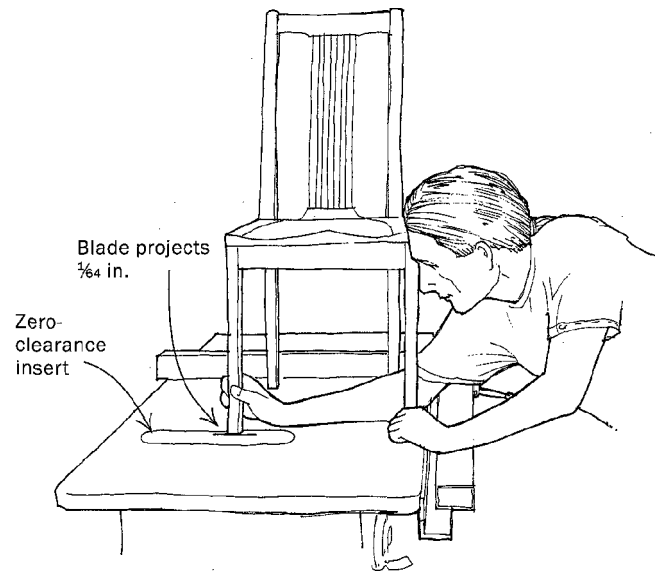

to build, easy to adjust and works admirably. The steady rest consists of a main body and four roller arms. For the body, I laminated two pieces of 1/2-in.-thick Baltic-birch plywood. I made the roller arms by mounting roller-blade bearings (available from large sporting-goods stores) to the ends of 6-in. lengths of T-slot

You've just built a chair, and you need to see if it wobbles. So you take it to the one guaranteed flat spot in your shop, which is probably the top of your table saw. You mark the high leg and then try to decide which torturous way you are going to trim that little bit off. Here's how I do it. Put a zero-clearance insert into the table-

A reward for the best tip

Robert D. Eberhardt won an engraved Lie-Nielsen handplane for the winning tip shown above. He got his start in woodworking by soaping screws for his grandfather, who built wooden fishing boats. Forty years later, Eberhardt is still using his grandfather's tools. He designed this steady rest to turn some spindles for his own bed. Send us your best tip, along with any photos or sketches (we'll redraw them), to *Methods of Work*, Fine Woodworking, P.O. Box 5506, Newtown, CT 06470-5506.

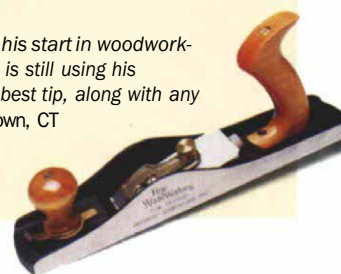

Methods of Work (continued)

saw. Drop the sawblade until it is below the bed and then raise it until it projects just a few thousandths of an inch, $\frac{1}{64}$ in. max. With your chair still sitting on top of the saw, turn the saw on and pass the offending leg sideways across the blade back and forth until the wobble is gone. This technique works equally well with small tables.
—*Tai Lake, Holualoa, Hawaii*

No-measure mitered boxes

Glue up beveled sides and top with masking tape or band clamps.

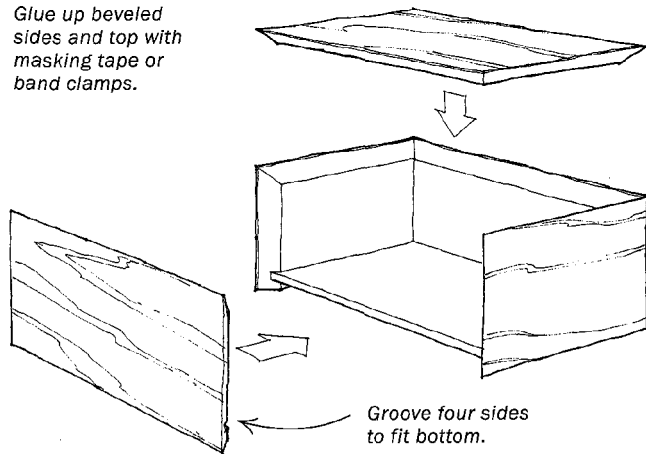

Cut bevels on top and sides at same saw setting.

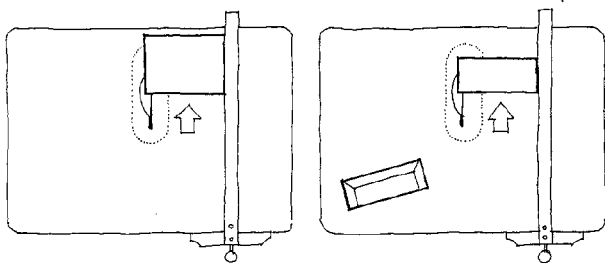

Here's a technique for making mitered boxes that eliminates all of the measuring and fussing to get the mitered parts to fit perfectly. I use the technique on veneered boxes with medium-density-fiberboard (MDF) cores, but the basic approach will work with any box where the four sides and top join with miters.

Start by applying veneer to a core piece for the top and the sides, including a little extra material for the mitered bevels. Rip all four sides of the box to width (box height) and then square the sides to a little over their final lengths. With the tablesaw blade set at 45° , bevel one long edge and one end of each side piece. Then bevel one edge and one end of the top.

Now set the fence to the desired width of the top. Bevel the other long side of the top and—without changing the fence setting—bevel the two short sides to length. Reset the fence to the desired length of the top and bevel the short side of the top. Again, without changing the fence setting, bevel the two long sides to length.

Run a $\frac{1}{4}$ -in.-wide by $\frac{1}{8}$ -in.-deep groove on the inside of each side

piece, $\frac{1}{4}$ in. up from the bottom edge. This groove will hold the bottom of the box. Cut the bottom from $\frac{1}{4}$ -in. plywood to fit the groove and glue up the box with web clamps or masking tape. Later, after the glue has set, saw the top off the box to produce the lid.

If your fence is square to the blade and your blade is accurately set at 45° , the joints are guaranteed to be perfect. The top will drop into the bevels in the sides with a satisfying precision.

—*Pat Griffith, Ottawa, Ont., Canada*

Router-cut pocket holes revisited

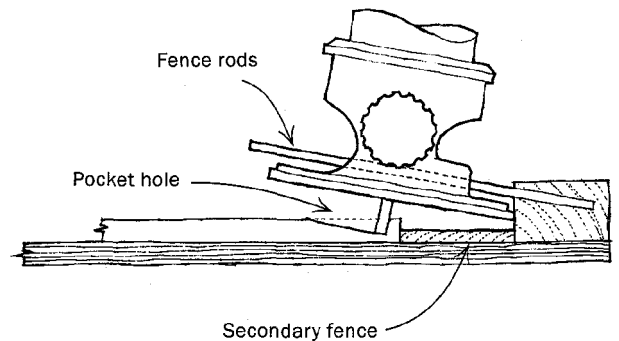
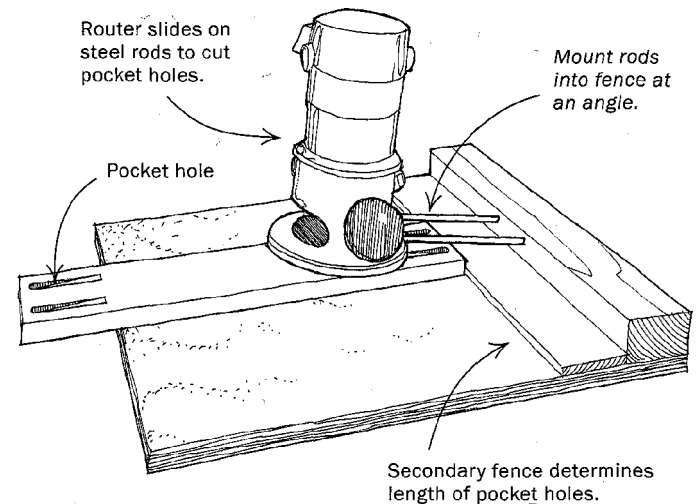

I liked Michael Csontos' idea for making pocket holes with a router and a sliding ramp (see *FWW*#134, p. 20). But the fixture seemed complicated to build, and it limited the width of workpiece that could be used. Here's another approach that doesn't limit the size of the workpiece. This approach uses the router's steel fence rods as sliding rails.

Start by making a full-sized, side-view drawing of the fence, the router base and the desired pocket holes. The drawing will give you the rod angles and locations in the fence. These two variables, along with the router-bit depth, control the length and depth of the pocket hole. Drill angled holes into the fence spaced at the right width to fit the router's fence rods. Attach the fence to a generously sized, $\frac{3}{4}$ -in.-thick plywood base. To use the fixture, slide the

Methods of Work (continued)

workpiece into position and clamp. With the router suspended above the workpiece on the fence rods, start the router and slowly slide it down toward the secondary fence to cut the pocket hole.
 —*Timothy Dalton, Middleton, Wis.*

Quick tip: Paint tea onto raw wood for an inexpensive and natural-looking stain. The stronger the tea, the darker the stain. After it dries, seal with shellac or varnish.
 —*Sam Bruin, Brooksville, Fla.*

Spring-action hold-in

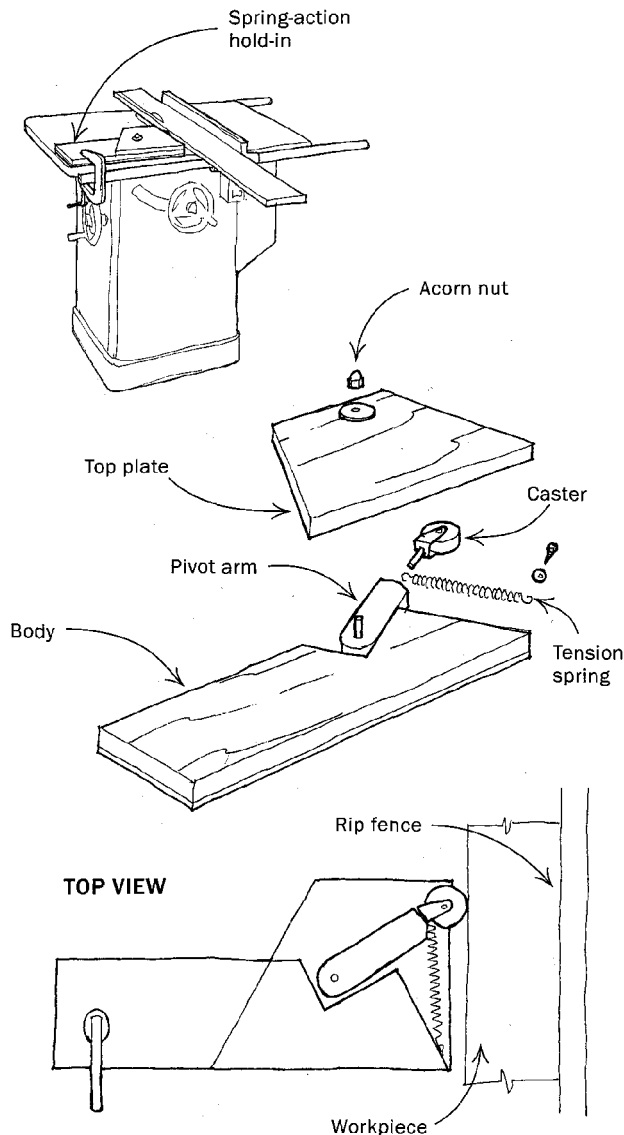

To make a safe, consistent cut on the tablesaw, it is important to hold the workpiece firmly against the rip fence. I have seen feather boards used for this purpose, but they are not very forgiving of variations in stock size, and they're awkward to clamp to the table. So I made this spring-action hold-in from wood scraps, a surplus caster and other hardware from my junk box.

The hold-in has several parts: a body laminated from 1/8-in.

Masonite and 3/4-in. plywood, a 3/8-in. plywood top plate, a pivot arm, a stem-type caster and a tension spring. The Z-shaped cutout in the body creates a positive stop for the pivot arm and allows a full 1 1/2 in. of spring-tensioned displacement of the caster wheel to accommodate lumber of different widths.

—*Steve Stem, Brooklyn, NY*

Making decorative turned columns for furniture

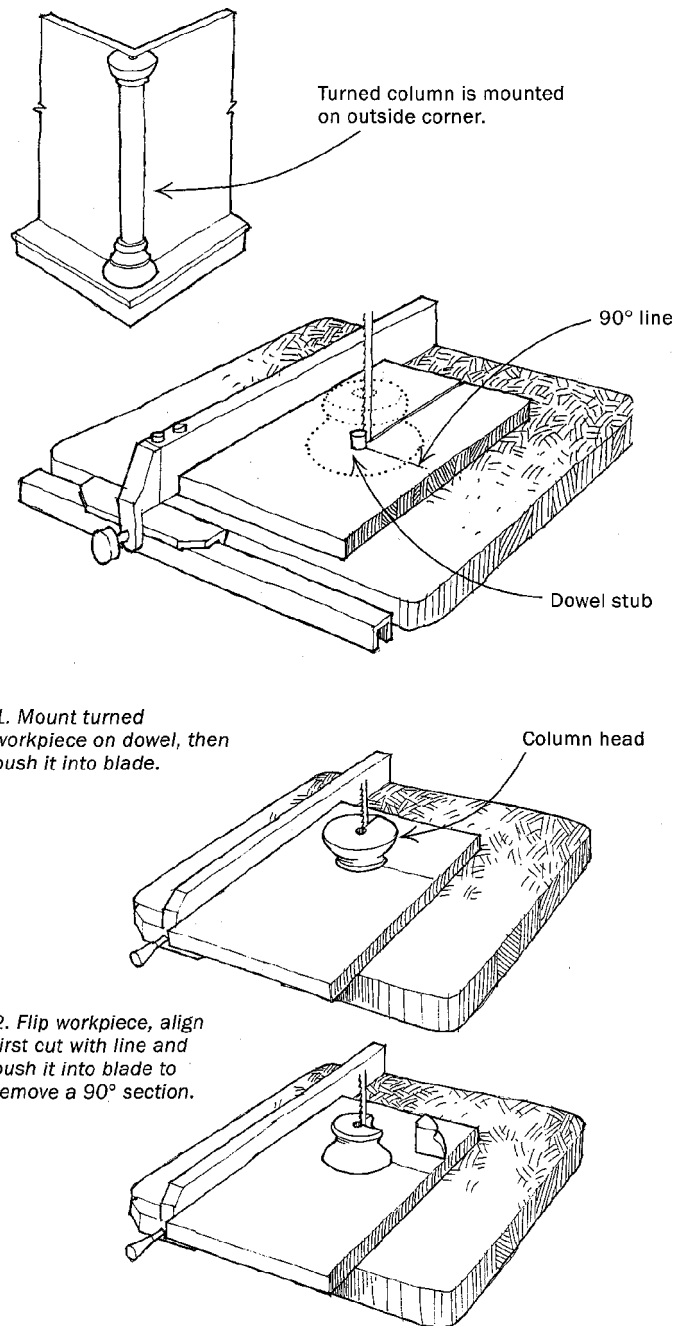

Turned columnlike decorations look great mounted on the outside corners of furniture or paneled walls. But to make the

Methods of Work (continued)

columns you have to remove much of the turned pieces to mount them properly. Here's how to remove the waste.

Start by turning the column midsection, head and foot from solid stock. Through the center of the head and foot, bore a hole to fit a commonly sized dowel. Remove a 90° slice from the midsection by screwing square blocks to each end of the column, run the column through your tablesaw and turn it 90° for the second cut.

To perform the same operation on the head and foot, construct a simple jig by mounting a dowel in a scrap of plywood or MDF. Mark a line on the top of the jig at 90° to the line of the cut. Mount the column head on the jig by pushing it onto the dowel and set the bandsaw fence with the cut line centered on the dowel. Push the jig into the blade and cut halfway through the head. Flip the workpiece, rotate the first saw kerf so that it is aligned with the 90° mark on the jig and cut again to remove the 90° wedge. Repeat the same operation with the foot.

—William Nyffeler, Newmill, Keith, Scotland

Installing crown molding

When I got the job of installing 200 linear ft. of large crown molding in a room with 10-ft. ceilings, I quickly discovered that this was no simple task. The main difficulty was holding long sections of crown in alignment along the wall as I tried to nail them in place. To achieve a consistent alignment, I first tried snapping a chalkline and placing the lower edge of the molding on the line. This procedure helped enormously but still allowed for too many varia-

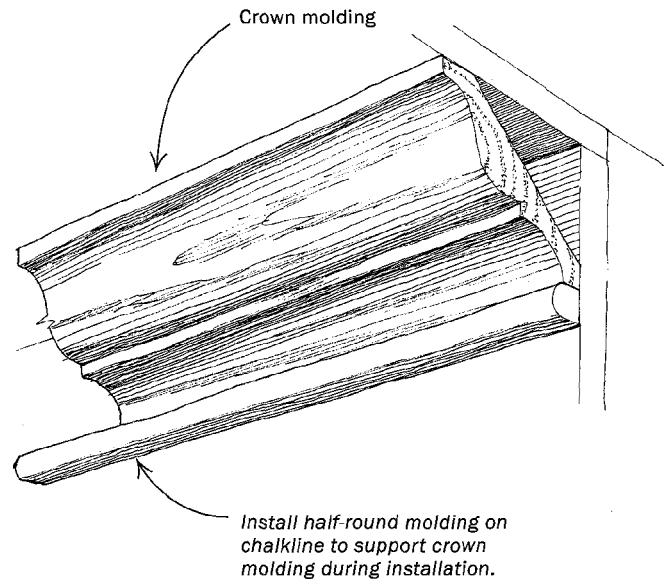

tions. Finally, I came up with a method that is almost foolproof.

I tacked a half-round molding of suitable dimension to the snapped chalk, flush to the wall. The half-round molding not only ensured consistent alignment but also provided a solid and stable ledge on which to place the crown and position it for nailing. If left

Methods of Work (continued)

in place, the half-round strip provides an additional architectural detail to the molding. This approach improved the quality of the job and simplified the installation.

—George L. Ziff, *Southern Pines, N.C.*

Quick tip: To protect my hands around the shop, I use inexpensive latex examination gloves, available by the box from wholesale supply stores (such as Sam's Club). The tight-fitting gloves are sensitive enough to operate machinery but strong enough to protect from splinters when handling rough lumber. They are surprisingly durable. As a bonus, the gloves leave my hands in dramatically improved condition at the end of the day, reducing the need for moisturizers and rehabilitation.

—Lawrence A Salibra II, *Gates Mills, Ohio*

Shopmade plywood carrier

Here is a carrier that makes it much easier for one person to handle full sheets of plywood or drywall. I know you can buy similar tools at home-improvement centers, but this shopmade version can be customized to fit your height and arm length, and it costs next-to nothing to make.

Dimensions of the tool are not critical. A height of about 12 in. works for many people. You should size the tool so that you don't have to stoop too far to lift a panel.

Make the handle from ½-in. EMT (electrical metallic tubing). The bend in the handle gives some clearance for your hand between

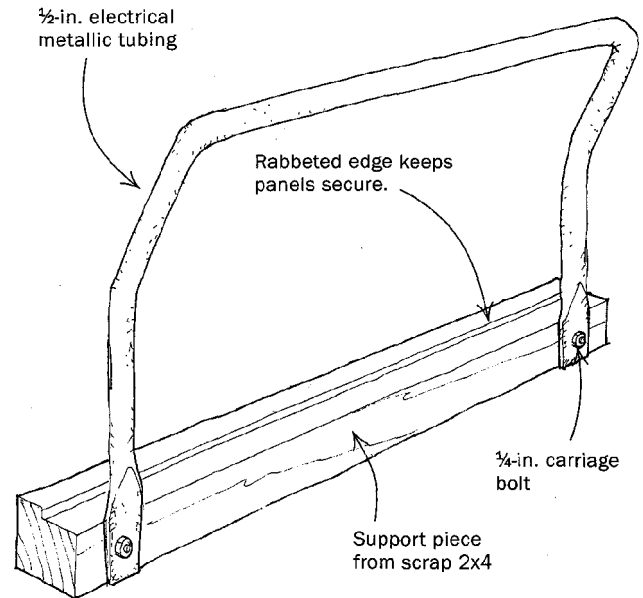

the handle and the panel. Flatten and drill the ends of the EMT for ¼-in carriage bolts. Cut the wood-support piece from a scrap 2x4. Bending the EMT is pretty tricky: Bend the U-shape first, then bend the uprights.

—James A. Meier, *Brighton, Mich.*

Methods of Work

EDITED AND DRAWN BY JIM RICHEY

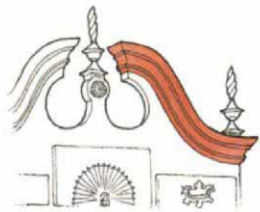

Shaping curved molding

For the past two years I've been working on a Queen Anne highboy similar to the one described by Randall O'Donnell in *FWW* #117-119. When the time came to work on the gooseneck pediment molding, I found that his approach (requiring

custom-made router bits) was too expensive for my one-off project. So I came up with this inexpensive, easy-to-build router carriage that will follow curved or straight stock and shape complex, curved molding in a few steps using ordinary router bits.

The carriage consists of two mahogany outriggers fitted with round-nosed ultra-high molecular weight (UHMW) polyethylene rub blocks. (UHMW is available from most mail-order woodworking tool suppliers.) My plunge router rides between the two outriggers on a bridge made from ½-in. cold-rolled steel shafts.

Because the guide rods that came with my router were metric and slightly too short, I enlarged the holes in the base to fit the new

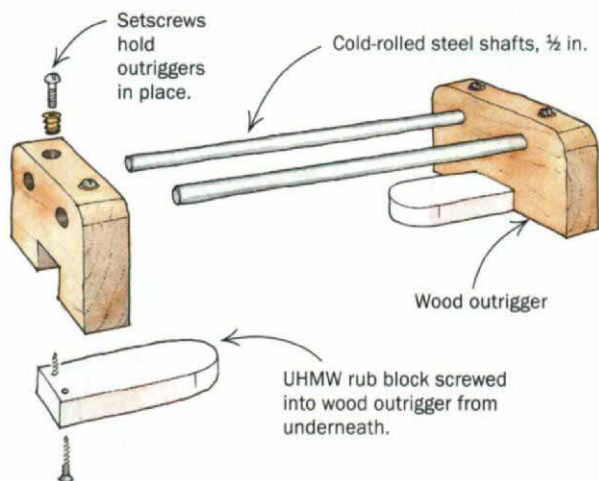
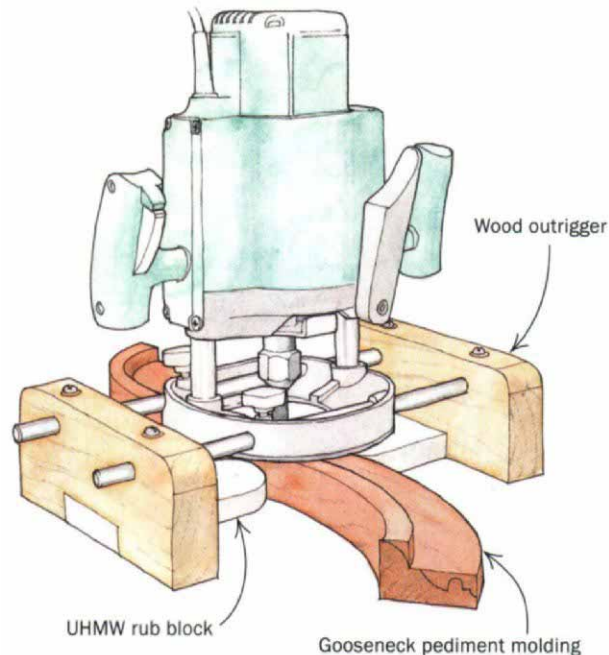

½-in. guide rods. I cut the outriggers to size, stuck them together with double-faced tape and carefully drilled holes through the pair to receive the new guide rods. Then I notched the outriggers and attached the UHMW rub blocks in the notches with screws.

To use the carriage, I cut two molding blanks with a bandsaw to rough shape, stuck them together with double-faced tape and sanded the pair to a uniform width. With the blanks prepared, I stuck them to my benchtop with double-faced tape. With the carriage placed over one blank, I adjusted the rub blocks to fit the material's width, then locked the outriggers into position with setscrews. I then made a dry run to be sure there was no binding along the way.

Shaping the molding was simply a matter of making a series of cuts with various bits to define the profile. The rub blocks will follow either a curved or a straight section. The bit can be adjusted up or down or moved side-to-side on the guide rods to make any cut your imagination and your selection of cutters will allow.

I recommend that you shape curved and straight sections at the same time with each setup. A bit of hand scraping and sanding will probably be necessary when the routing is done. If you're careful, the miters between curved and straight profiles will match perfectly.

—Richard C. McLean, Scio, Ore.

Fence-setting jig

There are times when you need the fence and the miter-gauge slot on a router table or a shaper to be perfectly parallel with each other, such as when you are coping the end grain of rails in paneled-door construction. This jig (see p. 20) lets you make small, incremental adjustments to the fence while ensuring that the fence remains parallel to the miter-gauge slot.

Start with a squared-up board about 4½ in. wide and 20 in. long. Cut the board lengthwise at about 6°. Attach one side of the board to a 2-in.-wide strip of ¾-in. plywood that has been pushed into the miter-gauge slot in a vertical position. Now remove a semi-circular area where the jig lines up with the cutter. Draw marks ½ in. apart on one side of the taper and draw a reference

A reward for the best tip

Richard C. McLean won an engraved Lie-Nielsen handplane for this issue's winning tip, a carriage for shaping curved molding. He plans to retire soon, after working for nearly 40 years repairing antiques and building fixtures for his local school district. McLean has been inspired only recently to build reproductions of 18th-century furniture. Send us your best tip, along with any photos or sketches (we'll redraw them) to *Methods of Work*, Fine Woodworking, P.O. Box 5506, Newtown, CT 06470-5506

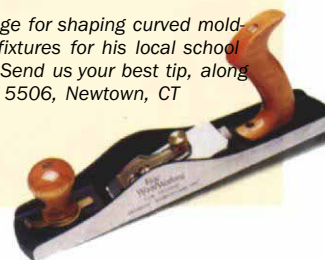
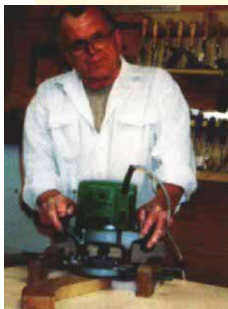

Methods of Work (continued)

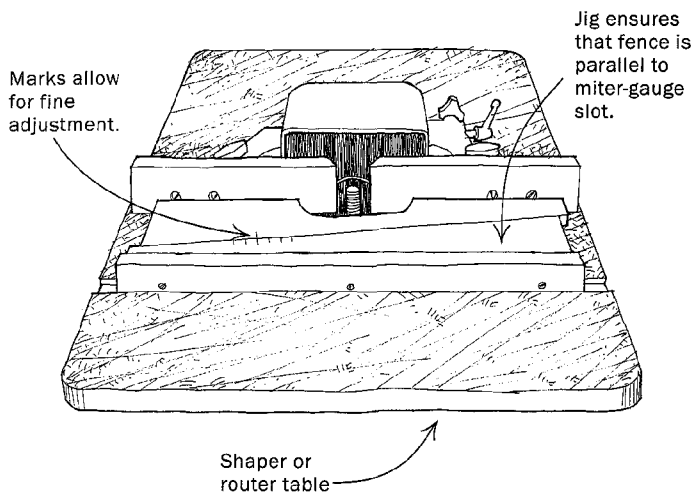

mark on the other. A movement of $\frac{1}{2}$ in. left or right should translate to just under $\frac{1}{16}$ in. in movement forward or backward in the fence. With this jig and the reference marks, it is easy to set the fence to make progressively finer cuts.

—Bjarn Sorensen, Tempe, Ariz.

Quick tip: Wood filler made with sanding dust and polyurethane glue gives a much better color match and takes the stain better than filler made with yellow glue. Clamp wax paper and a scrap of wood over the repair to prevent the filler from foaming out.

—Jack Kashtan, Sacramento, Calif.

Routing dovetails on turned posts

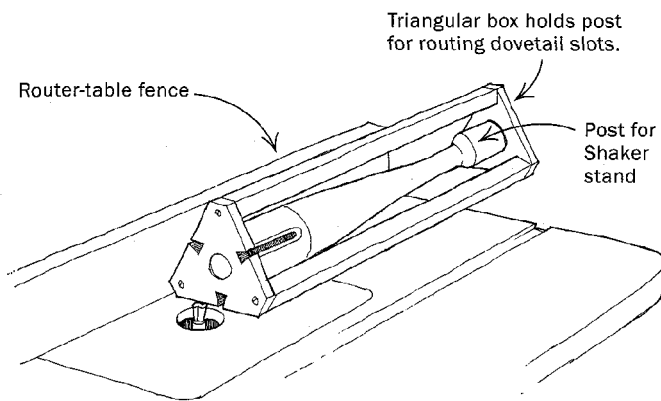

Remove stub on bottom after routing slots.

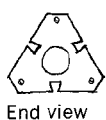

End view

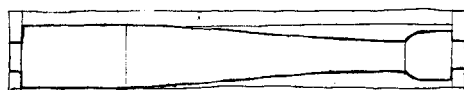

Side view

for cutting the sliding dovetails into the base of the post. The usual approach is to index the post between centers on the lathe and build a box above the lathe ways that allows a sliding router to cut the dovetails. Being a one-armed woodworker, I didn't feel comfortable with this approach.

Instead, I made a fixture that is basically a triangular box. The post is locked into the box by stub tenons turned on both ends of the post that fit tightly into holes in the triangular ends of the fixture. I cut the dovetails by sliding the fixture along the router-table fence, then I remove the stub tenon on the bottom of the post.

To cut the slots, I used three router bits: A $\frac{3}{4}$ -in. straight bit to mill a flat (the base of the turned post protrudes slightly from the triangular box before you make this cut), a $\frac{1}{2}$ -in. straight bit to hog out the bulk of the waste and, finally, a dovetail bit to rout the dovetail slot. It is essential to use a stop block to control the length of the router-bit cuts. This jig is less trouble than a lathe jig and just as accurate and convenient, even for woodworkers who have two arms.

—Leslie Davis, Tottenham, Ont., Canada

Roll-pin screw extractor

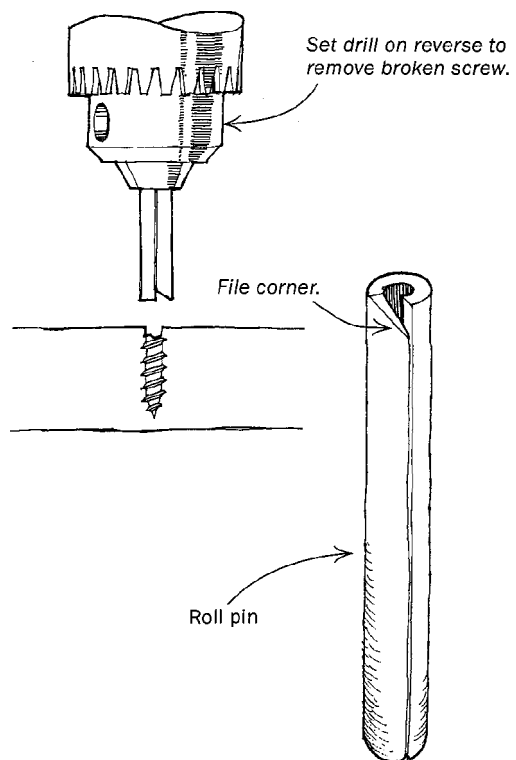

Have you ever tried to drill out the stub of a broken screw from your prized project, gone off center with the drill and ruined the surrounding wood? Or tried to dig it out with an awl? Or bought an expensive left-hand drill bit to try to back out the broken piece?

Here is a cheap and easy way to avoid these nightmares. Take an ordinary hardware-store roll pin and file off one corner at the seam to make the pin into a left-hand drill bit. Install the pin in your drill, set the drill on reverse and drill around the broken screw. Roll pins are commonly available in sizes of $\frac{1}{16}$ in., $\frac{3}{16}$ in. and

Methods of Work (continued)

¼ in. The ¼-in. pin will drill a nice, clean hole that you can fill with a plug. The smaller sizes will usually drill down about halfway on to the screw shank, then catch it and back it out completely.

—William Tiemeyer, Cincinnati, Ohio

Clamping keel for a machinist's vise

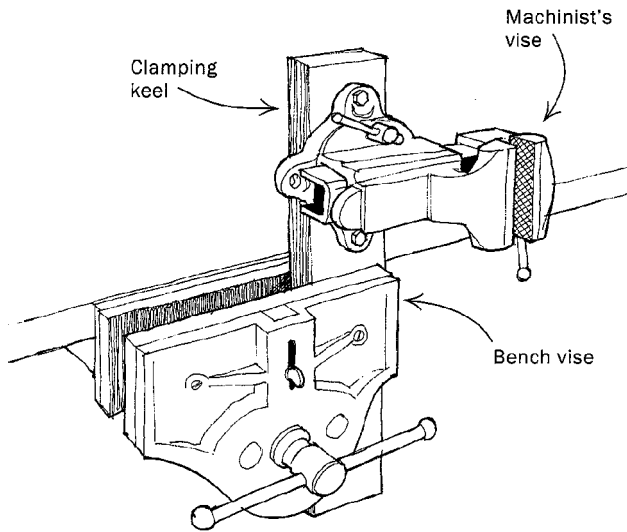

When I needed to change the clamping orientation of some panels I was sanding, I attached a 2x4 keel to my machinist's vise, clamped it in my bench vise and reoriented the workpiece as shown in the sketch. This dual-vise arrangement worked so well that I've used it for other jobs. It provides an endless variety of holding angles, is quick to set up, costs nothing and makes good use of my machinist's vise, which needed a good dusting anyway.

—James J. Rankin, Easton, Pa.

Pipe-clamp stain protectors

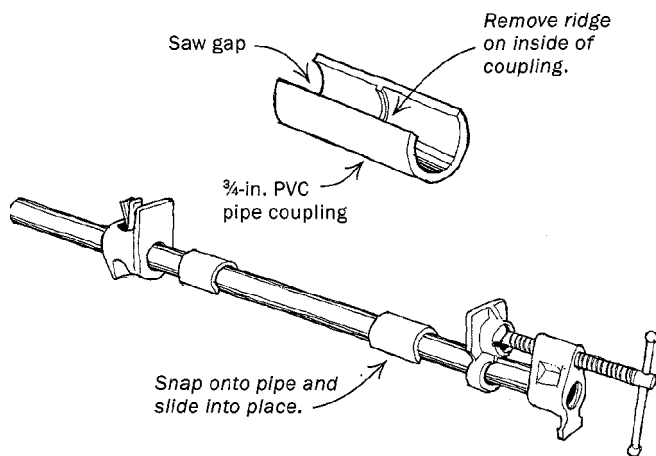

Tired of having your pipe clamps stain your work where the pipe contacts a glue joint? Here is a way to avoid the problem. Purchase several schedule-40 PVC pipe couplings for ¾-in. pipe or ½-in.

pipe, depending on the size of your pipe clamps. Be sure to get the white PVC fittings: The beige ones won't work.

With a bandsaw or a hacksaw, cut away approximately one-third of the coupling to leave a gap in the circumference. Remove the small ridge inside the coupling with a small sanding drum or a sharp chisel and mallet. Sand the rough edges and snap two of the protectors onto each pipe between the clamp ends. Slide the protectors into position where they are needed.

—Jay E. Rubel, Atlanta, Ga.

Two-fence router mortising

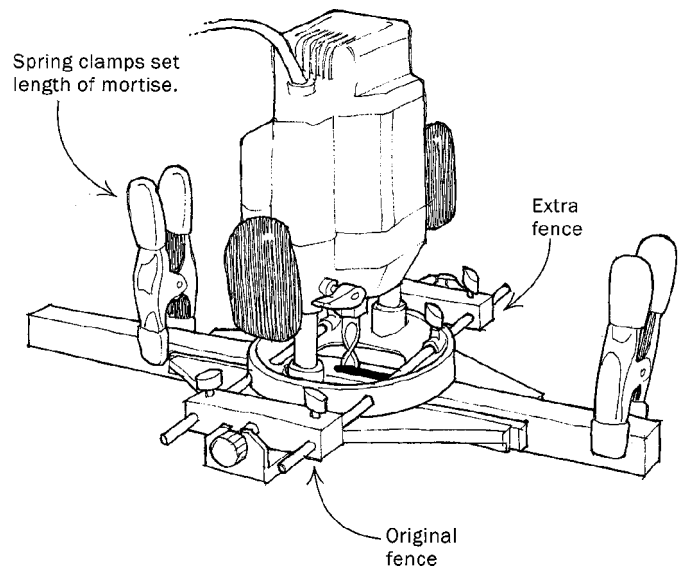

By adding an extra fence to your router, you can cut mortises quickly and accurately, and you virtually eliminate the risks of the router wandering or tipping into the cut. Start with a router that has a substantial fence equipped with a threaded micro-adjustment mechanism. Buy a second fence and attach it to the rails, extended through the router base so that it faces the original fence. Sandwich the workpiece snugly between the two fences, and make the necessary micro-adjustments to align the bit with the desired mortise location. Trial cuts on a scrap piece can best confirm the correct alignment. Attach spring clamps to the workpiece to limit the router's travel, and set the length of the mortise.

To cut the mortise, raise the bit from the work, turn on the router and move it back and forth in the plunge cut until you reach the desired depth. I prefer a spiral up-shear bit for mortising because it clears the chips better than a straight bit does.

This dual-fence arrangement works well when I have to make a series of in-line mortises for Shaker or Mission-style furniture. When mortising close to the end of a workpiece, such as the top of a leg, clamp two legs together in the vise end-to-end to provide more support for the router.

—Mandy Kotzman, LaPorte, Colo.

Quick tip: To eliminate that gummy, sticky feeling when sharpening a chisel on a waterstone, add a couple drops of paint thinner to the water. Presto! The blade will glide smoothly over the stone.

—R.J. Fowler, New Westminster, B.C., Canada

Methods of Work

EDITED AND DRAWN BY JIM RICHEY

Lifting mechanism for sheet goods

Working in a small shop has its advantages and disadvantages. One disadvantage is that there is not always someone around to help with the heavy lifting.

I added a larger auxiliary top to the tablesaw to make it easier to handle full sheets of plywood, but getting the plywood onto the saw was still a problem. To solve that difficulty, I outfitted the saw table with a lift that allows one person to raise a sheet of plywood onto the saw easily and with less risk of damage.

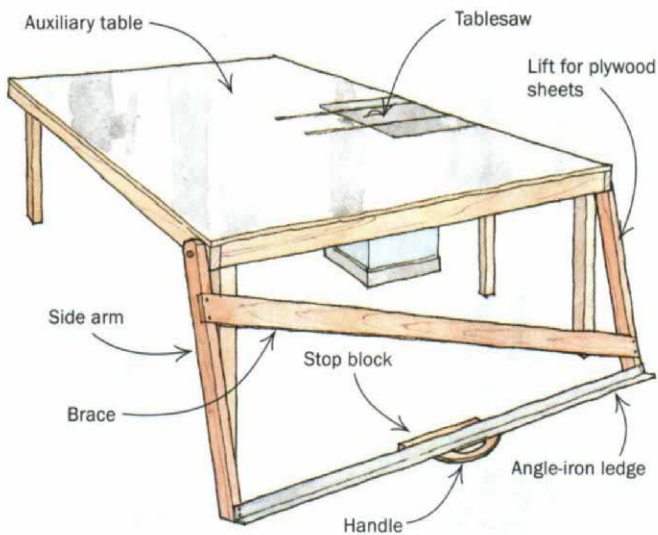

The construction is simple. Cut two 2x4 side arms approximately 1 in. longer than the height of the table. Drill and attach the side arms, one to each side of the auxiliary table, so that they will pivot (I used 1/2-in. bolts with washers and nuts). Cut a length of 2x2 angle iron long enough to span the side arms. Screw a 1/2-in. plywood handle to the underside of the angle iron and then secure the angle iron to the bottom of the side arms to provide a ledge for

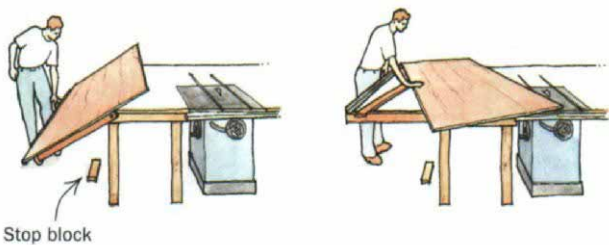

the sheet goods. Let a 1x4 diagonal brace into the 2x4s, to keep the lift from racking. Screw a 2x4 stop block to the floor so that the lift stays approximately 1/4 in. off the floor and at a slight angle away from the table. This will keep the lift from binding when under a load and keep a sheet of plywood from tipping back toward you after you place it on the lift.

To use the lift, set a sheet of plywood on the angle-iron ledge and lift the sheet level with the table. Then simply push the sheet onto the table and slide it into place for ripping workpieces to size.

—Garett S. Craft, Rantoul, Ill.

Improving the performance of spade bits

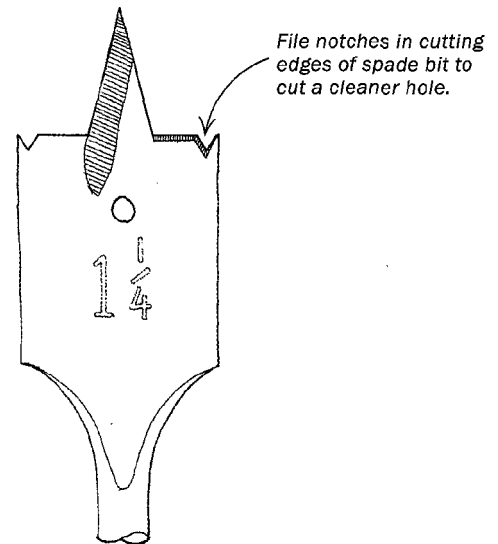

Woodworkers often overlook the lowly spade bit, but it does have some advantages. It certainly is the cheapest bit and the easiest to sharpen. And if you need a nonstandard size or a tapered hole, you can easily grind a bit off the sides.

It does not drill a clean hole, you say? Well, just file a notch on each edge of the blade, as shown in the sketch. Essentially you are making spurs to sever the wood fibers cleanly on the wall of the hole. As you drill, go slowly when the flat of the bit first contacts the work. You will find that the wall of the hole will be crisp and clean—maybe even cleaner than with those other fancier bits.

—Tim Hanson, Indianapolis, Ind.

Quick tip: When working with sheet goods, I trim the pieces to an approximate size with a handheld circular saw. Then, before I make any final cuts, I put down a piece of 2-in. masking tape,

A reward for the best tip

Garett S. Craft won an engraved Lie-Nielsen handplane for his winning tip that takes the grunting out of hoisting sheets of plywood. Craft worked part-time in his father's cabinet shop in Rantoul, Ill., while he studied industrial design at the nearby University of Illinois. After graduating in 1997, he came back to work full-time rather than spend his days sitting in an office. He likes the freedom to take off and go fishing once in a while. Send us your best tip, along with any photos or sketches (we'll redraw them) to Methods of Work, Fine Woodworking, P.O. Box 5506, Newtown, CT 06470-5506.

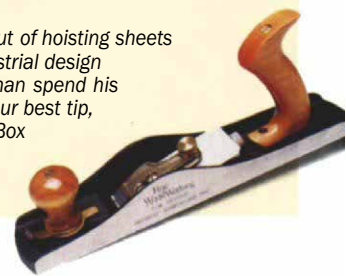

Methods of Work (continued)

affixed directly to the wood. I can then mark my final cut line on the tape. The tape all but eliminates tearout.

—Craig Duff, Del Rio, Texas

Painless miter joints

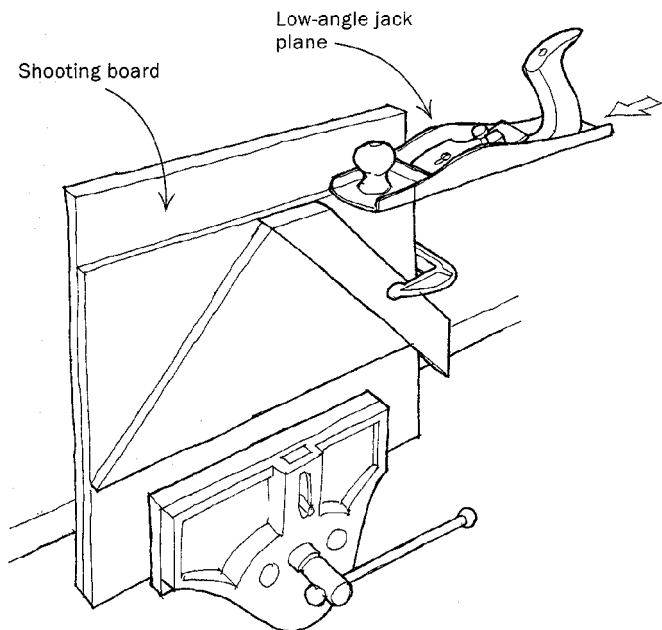

Cut kerfs for veneer splines with stiff-backed saw.

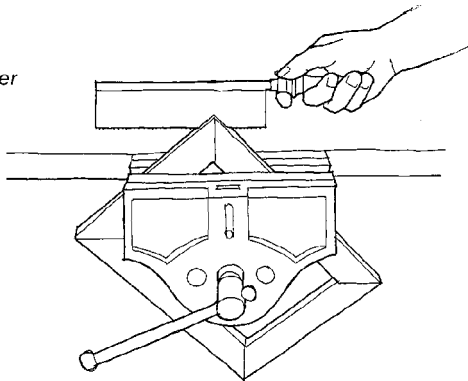

Making strong, tight miter joints can be a daunting job. Miter joints are inherently weak, hard to clamp and—for me—difficult to cut accurately. Notwithstanding those obstacles, I've discovered a couple of tricks to cut tight, strong miter joints quickly and easily.

First of all, I rough-cut the mitered members on my chopsaw. Then I move each frame member to a shooting board, where I can quickly produce a dead-accurate polished miter with a low-angle jack plane, as shown in the sketch. I seal the end grain with a thin coat of glue, let it absorb into the end grain, then add a little more glue and assemble the joint. If I've done a good job shooting my miter cuts, the whole thing almost holds itself together with just the tack of the glue. I then add one of those nifty little pinch clamps to each corner—the kind that are applied by hand. (The ding that the pinch clamp makes is eliminated in the next step.) Masking tape also works well to pull the miter joints together.

After the glue has thoroughly set, I carefully clamp one corner of the frame in my vise at 45°. Using a stiff backsaw or dovetail saw I cut a kerf in the joint to accept one or two reinforcing splines. I cut spline material from veneer, apply glue, insert the spline in the kerf and clamp across the kerf. Once the glue has set, I plane or sand off the protruding portion of the spline.

—Andrew Dizon, San Diego, Calif.

Quick clamp from a caulking gun

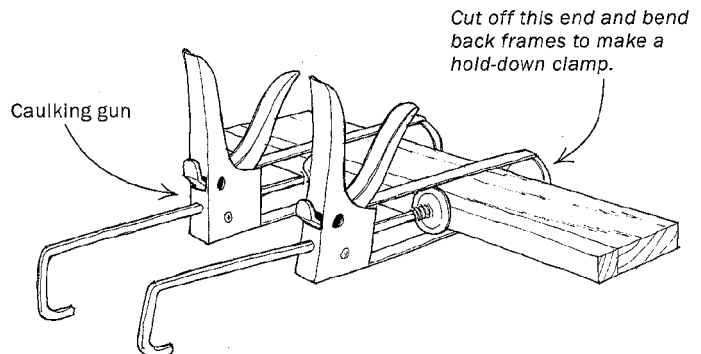

The widely available caulking gun (we call it a sealant gun in England) makes a quick, cheap clamp. Simply remove the tube of caulk, place the item to be clamped between the plunger and the frame and tighten the gun. Add a little block of wood in the nose area if you wish. Most caulking guns will work, but some of the fancier models have a pressure-release feature that makes them unusable for clamps.

By cutting off the nose of the frame and bending the remaining frame ends, you can utilize the gun's clamping mechanism as a hold-down or clamp in a wide variety of jigs and fixtures.

—Alan Carter, Shawford, Winchester, England

Laminating boards with pipe clamps

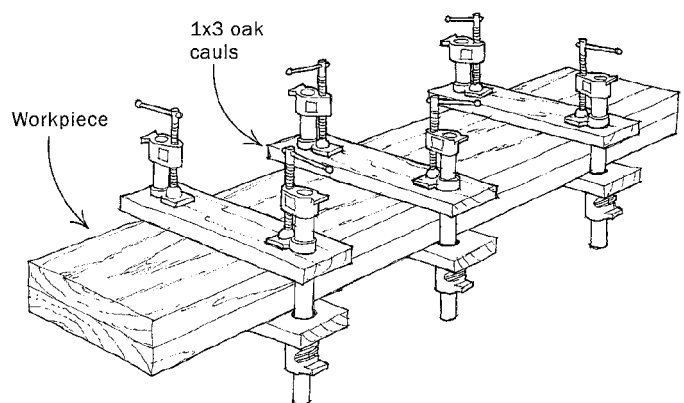

When I needed to laminate two wide boards to make thicker stock for chair legs, I devised a simple fixture to apply clamping pressure across the entire width of the boards. To make it you will need several pairs of pipe clamps and an equal number of stout hardwood (I used 1x3 oak) cauls. Cut the cauls longer than the

Methods of Work (continued)

widest boards you will be laminating. Drill holes at each end of the cauls to fit the outside diameter of the pipe, and clamp the assembly, as shown in the sketch on p. 20. —*Susan Cosmos, Piru, Calif.*

Avoiding planer snipe on short stock

Scrap strips extend 4 in. on each end.

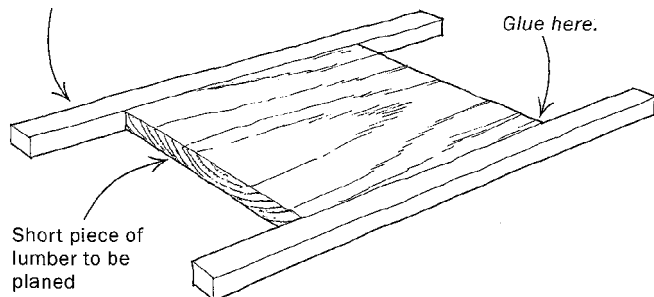

When you need to put a short piece of wood through the thickness planer, here's how to eliminate snipe at each end of the workpiece. Cut 1-in.-wide wood strips about 8 in. longer than the workpiece, and glue one strip to each edge, as shown above.

Now run the workpiece through the planer, taking thin cuts until it is the desired thickness. Any snipe will appear at the ends of the strips, not in the workpiece. Use yellow glue. Cyanoacrylate glues (like Hot Stuff) will make a mess of your jointer blades when you clean up the edges after sawing away the strips. This technique works equally well with a jointer.

—*Roger Russell, Anderson Island, Wash.*

Scroll-saw rasp made from sawblades

Rasp built up from multiple blades

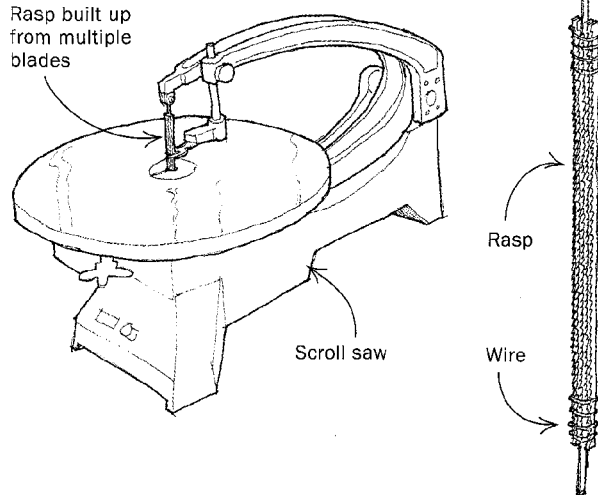

This miniature power rasp fits into a stationary scroll saw or jigsaw and is useful for touching up and squaring joint members such as tenons. Start with five coarse scroll-saw blades, a length of fine wire and epoxy. With pliers, snap off both ends of all four blades

at the last tooth. Build a sandwich with two of the shortened blades on each side of the center (unbroken) blade. Coat the last ½ in. of each blade with epoxy, place the blade assembly face-down on a flat surface to align the teeth and wrap the ends tightly with the fine wire.

After the epoxy hardens, install the rasp in your scroll saw or jigsaw. It may be helpful to clamp a narrow block of wood on the saw table behind the rasp to provide support at the back of the blades.

—*Walter Sheard, Horseheads, NY.*

Quick tip: Clear cellophane packing tape is great for clamping solid-wood edging to plywood. It can be stretched to apply an amazing amount of pressure. —*Thomas Love, Delmont, N.J.*

Using biscuits for adjustable shelf supports

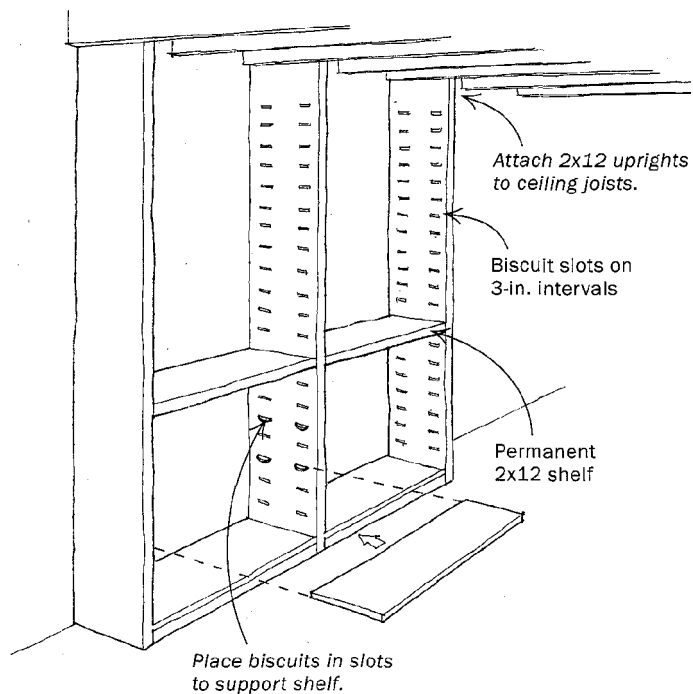

When I needed adjustable, sturdy utility shelves in my basement, I came up with the ideas of attaching the vertical members to the floor joists overhead and using biscuits for the shelf supports. I used 2x12 lumber for the uprights and permanently attached one 2x12 shelf to them. These permanent shelves link all of the uprights and give some rigidity to the structure. Other construction details are shown in the sketch.

For the adjustable shelves I cut an array of biscuit slots at 3-in. intervals on the surface of the uprights before installing them. I used a jig to ensure that every upright would have identical slot spacing. I set the biscuit joiner at maximum depth and used #20 biscuits—that way there is more of each biscuit in the slot than there is sticking out of the slot. To install a shelf, I simply pop four biscuits in the slots and place the shelf on top of them. I tested my design first and found that one shelf could easily support my weight of 185 lbs

—*Robert S Gehret, Hampstead, Md*

Methods of Work

EDITED AND DRAWN BY JIM RICHEY

The 25 Best Tips from Methods of Work

Since *Methods of Work* first appeared in issue #5 (Winter 1976), our readers have made it clear that they enjoy this section of the magazine. Finding a cheaper, easier, faster and more efficient way of doing things seems to represent a universal pleasure for woodworkers. Jim Richey took over editing the items and drawing the artwork for *Methods* with the publication of issue #16 (May/June 1979), and he's been doing it ever since.

Richey's association with *Fine Woodworking* came as a labor of love. He had

another career, until he retired last year, working for 27 years in a number of information technology jobs at Conoco, an oil and energy company.

Except for one painting course in college and one shop class in high school, his drawing and his woodworking skills are all self-taught. Now that he's retired, he spends a lot of time in his shop at home in Oklahoma and working on his vacation home in Colorado.

To celebrate this special anniversary issue, Richey pored through past issues

and chose 25 of his favorite tips and redrew all of the artwork in color. In cases in which the original text or drawings were not as clear as we felt that they could be, we made changes accordingly. Some of these tips are classics that will continue to save generations of woodworkers time and money.

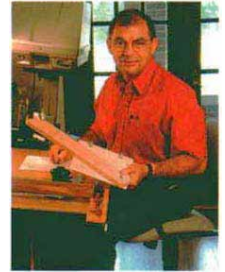

Wooden mallet

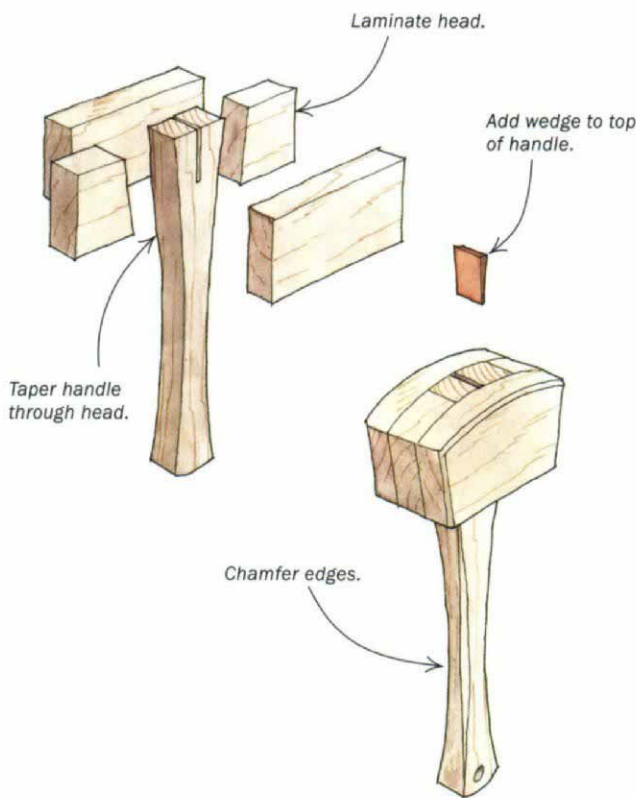

FWW #21 At least one wooden carpenter's mallet belongs in every woodworker's tool chest. The advantages of wood over steel are obvious—less damage to tools, work, thumbs and eyes. For the price of one steel hammer, you can make a dozen mallets, each tailored to a particular job.

The traditional mallet has a solid-wood head mortised through for the wedge-shaped handle. My laminated head design (above) is just as strong and much easier to make. Begin by cutting the handle and two center laminations for the head from the same 1-in.-thick board (this saves a lot of fitting later). Copy the handle's

wedge angle (no more than 1/2 in. of taper) onto one of the side laminations. Then glue up the head, aligning the center laminations with the wedge-angle pencil lines. When the glue has cured, bandsaw the head to shape. Then chamfer all the edges to reduce the chances of splitting and insert the handle.

—Daniel Arnold, Viroqua, Wis.

Jig for cross-grain routing

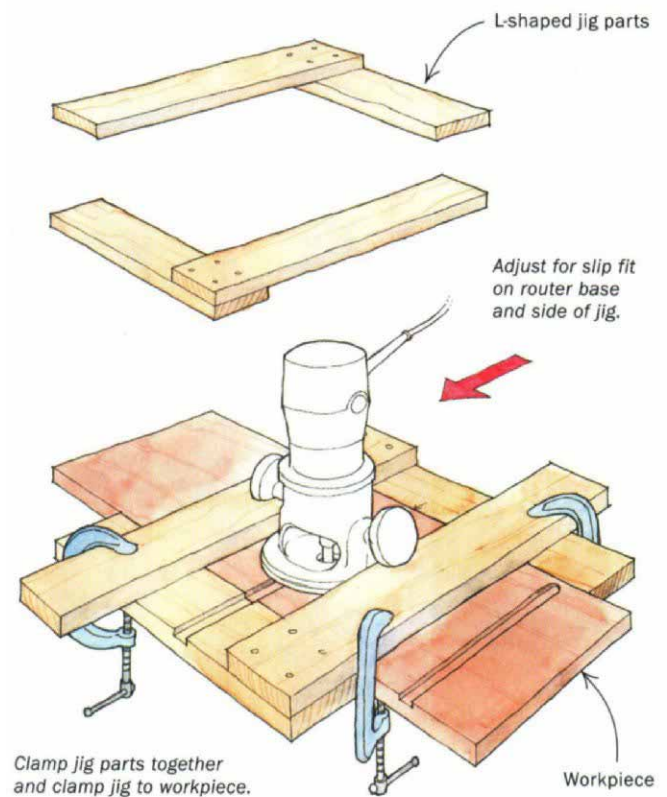

FWW#17 The concept is simple, but this jig is indispensable for routing dadoes in carcass sides, especially when several dadoes

Methods of Work (continued)

are to be made in one board. Once the jig is clamped together, you can slide it quickly into position for the next cut.

Make up two L-shaped pieces with 4-in.-wide plywood strips. Cut the shorter pieces of the L 16 in. to 18 in. long (router base plus 8 in. to 10 in.) and the longer pieces 20 in. to 30 in. long (widest carcass plus 8 in.). Face-glue and screw the pieces together, taking care to maintain a 90° angle.

To use, place one L on the front edge of the board to be routed and one on the back edge so that the two Ls form a woven rectangle (see the drawing on p. 24). Adjust both directions to give a slip fit against the router base and against the sides of the board. Then clamp the intersections of the two Ls. Pencil in an index mark on both sides of the jig to simplify lining up for a cut. Clamp the jig to the board before routing the dado.

—Roger Deatherage, Houston, Texas

Determining grain direction for handplaning

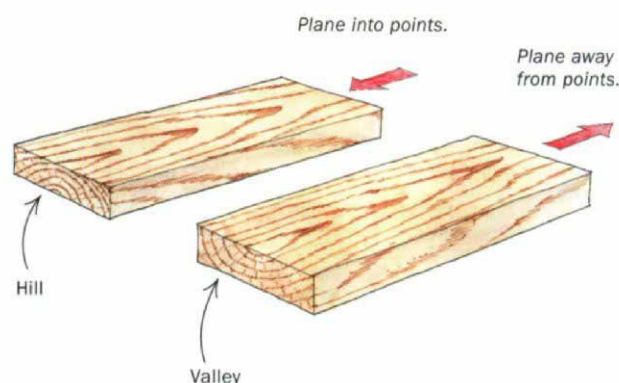

FWW#119 When handplaning boards, it is sometimes hard to know which direction to choose to avoid tearing out the wood. Checking the grain on the side of the board is a help, but that does not always tell the whole story. Here is an additional method that works very well.

Look at the end grain of the board. With flatsawn lumber you get one of two patterns: hills or valleys. Then look at the surface of the wood to see where the grain forms rounded points (called cathedrals). If the end grain is a hill, plane into the points. If the end grain is a valley, plane away from the points.

To help me remember the somewhat complicated directions, I think of an imaginary battle where a band of warriors charges up the hill and into the points of their enemy. The warriors retreat and run back into the valley with the enemy's points at their backs.

—Billy King, Oldhams, Va.

Cleaning sawblades

FWW#6 Oven cleaner works very well for removing pitch from router bits and sawblades without harming the steel. A clean-cutting surface stays sharp longer, gives better results, taxes the motor less and makes for safer use of the tool.

—Chuck Oliver, Fremont, N.H., and George Eckhart, Kenosha, Wis.

How to fold sandpaper

FWW#45 An old paint salesman showed me how to get the most out of a sheet of sandpaper. Fold the sheet in half in both direc-

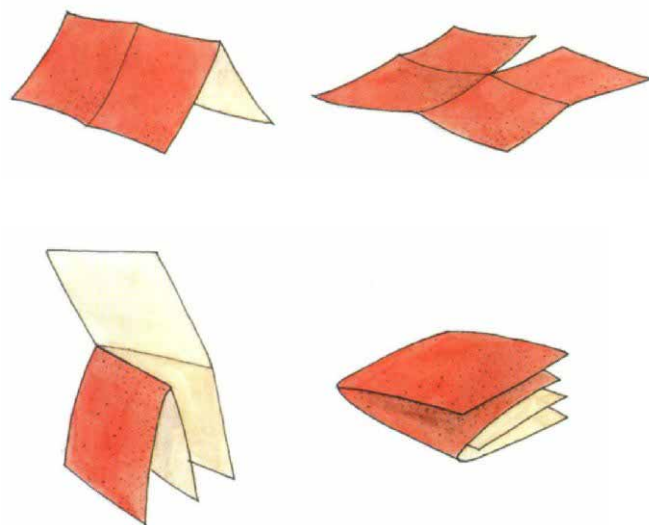

tions. Then tear the sheet halfway through on the short fold line. Now fold up the sandpaper into a four-layer sanding pad.

The sheet can be refolded different ways to expose a fresh surface. None of the sanding surfaces rub against each other, which results in a longer-lasting sanding pad.

—Steve Chastain, Bellingham, Wash.

Foot switch for tablesaw

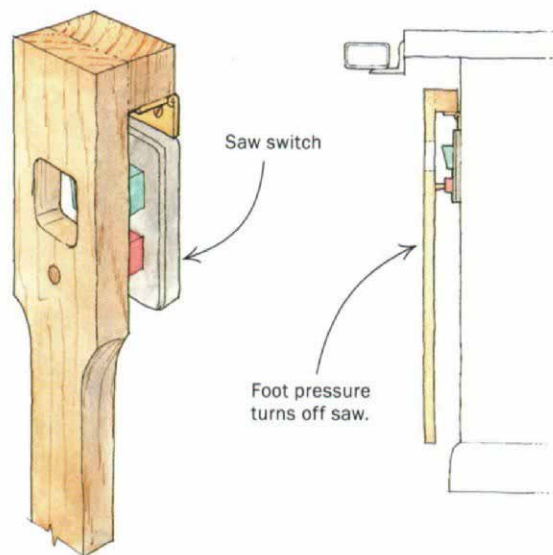

FWW#62 This foot switch is for those of us who, with both hands critically occupied on top of the saw table, have wished for a third hand to reach under the table and turn off the saw. I added the switch to my saw primarily for safety reasons but now find its convenience indispensable.

The foot switch is simply a hinged paddle that hangs down over

Methods of Work (continued)

the saw's push-button switch box. I can turn off the saw by bumping the paddle with knee or foot—a short dowel located at just the right spot pushes the off button. A hole through the top part allows normal finger access to the on button and, in fact, offers some protection against the button being pushed accidentally.

—Eric Eschen, Chico, Calif.

Cutoff box

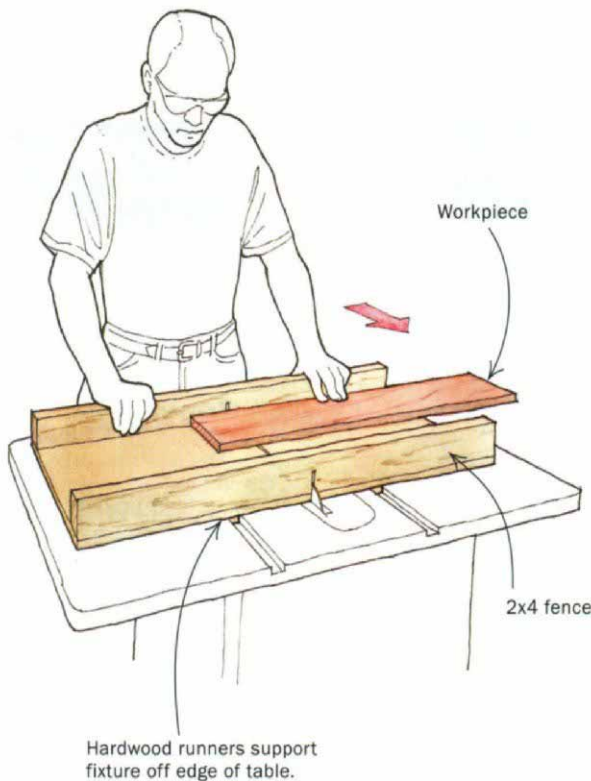

FWW#19 This easy-to-build box is superior to the miter gauge for simple 90° cutoff work on the table saw. Right-angle accuracy is built into the fixture; there's no adjustment necessary. Also, because the work is supported on both sides of the cut, there is none of the creeping that plagues cutoff work when you are using a miter gauge.

Although the size of the fixture is discretionary, I suggest you make it just a little smaller than the table saw top. For a typical saw this will give you room to handle work that's 18 in. to 24 in. wide. Make the bed from $\frac{3}{8}$ -in. plywood and the fences from 2x4s. Glue and screw the fences to the bed (avoid putting a screw in the path of the blade). Cut the hardwood runners so that they slide easily in the miter-gauge tracks and support the bed about $\frac{1}{4}$ in. off the table. Be very accurate in attaching the runners, and you'll always get a square cut.

—Jon Gullett, Washington, Ill.

Cove molding on the table saw

FWW#126 If you cut lots of cove molding on your table saw, this fixture will certainly repay the time invested in making it. The fixture requires a T-shaped miter-gauge slot, which is found on most new table saws. To make the fixture, start by selecting a

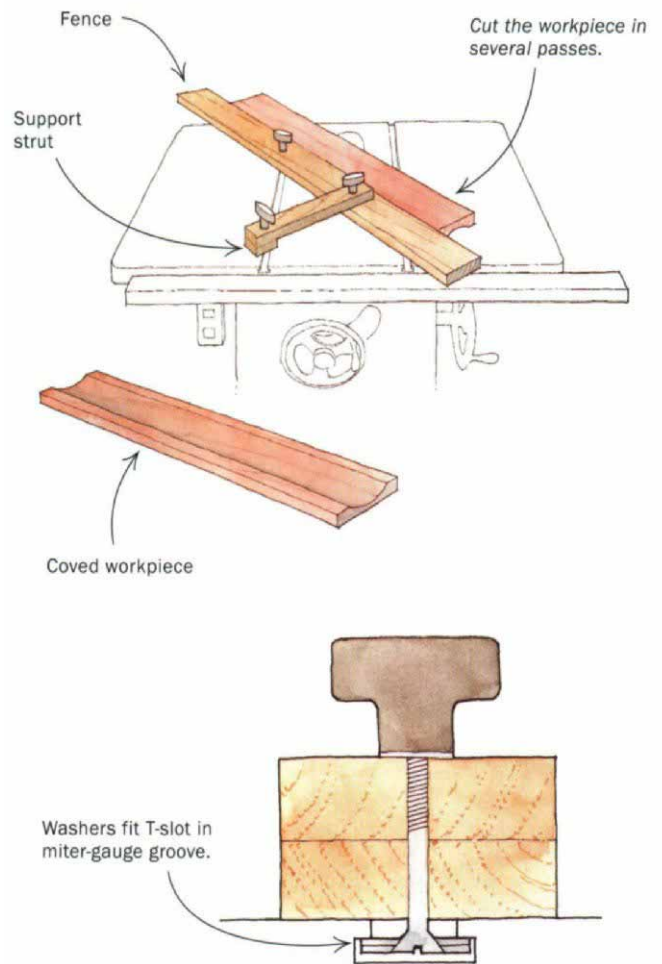

flat washer that fits the T-slot. Countersink two washers to fit the head of a machine screw. The washers and screws will provide hold-downs for adjusting and locking the fence in place.

Select a clear, straight $1\frac{1}{2}$ -in.-thick board for the fence. Assemble the fence and the support strut with the hold-downs and knobs, as shown in the drawing above. You can buy the knobs or make your own.

To adjust the fence, set the sawblade at the full height of the finish cut. Move the fence to the near side of the blade. With a second straightedge held just tangent to the far side of the blade and parallel to the fence, vary the angle of the fence until you get the correct width of the cove between the fence and the straightedge. Tighten the knobs to lock the fence in place, lower the blade until about $\frac{1}{16}$ in. protrudes above the table surface, and make the first pass to produce a small concave cut. Make successive cuts raising the blade $\frac{1}{16}$ in. on each pass until you reach the desired cove depth.

—Roy H. Hoffman, Oriental, N. C.

Fixing jointer-knife nicks

FWW#32 If your jointer knives get nicked as a result of hitting a nail or other obstruction, you can slide one knife a fraction of an inch to the right and another knife a little bit to the left. Leave the third knife in its original position. Because the nicks will be

Methods of Work (continued)

out of line, the jointer will surface lumber as smoothly as it did originally.
—Eric Schramm, Los Gatos, Calif.

Waxing saw tables

FWW#6 On all machine platens—such as saw tables and jointers, bottoms of planes, etc.—use a good car wax such as Simoniz, and you will be surprised by the results. Wood will slide and not stick, and rust will not form on the waxed surfaces in wet weather. I use it on all of my chisels and any tool that comes in contact with the wood.
—Ellis Thaxton, Arlington, Texas

Center finders—three variations on a theme

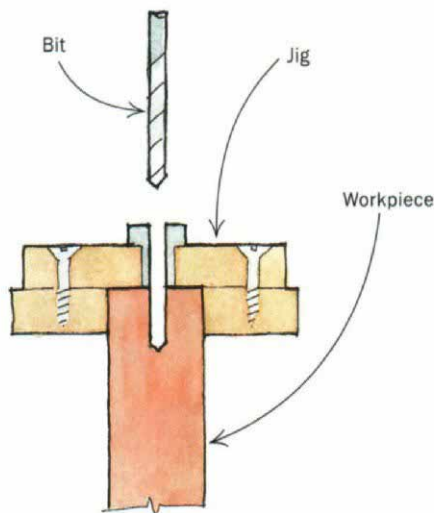
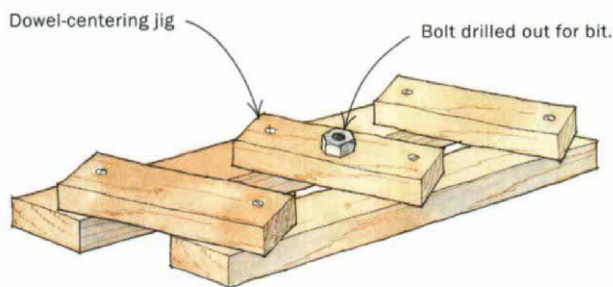

FWW#43 An old organ-builder friend showed me this handy homemade guide for center-drilling holes in the edges of boards to be doweled and edge-glued. The device consists of five sticks of hardwood screwed together in the configuration shown in the drawing above.

The sticks should pivot so that the device collapses like a parallelogram. For the drill guide, fit the center strip with a hex-head bolt $\frac{1}{8}$ in. larger than the bit size. Then, using a drill press for accuracy, drill a pilot hole through the bolt using a bit one number larger than the bit you intend to use for doweled. To use, first align the edges of the boards and mark off the dowel locations with a square. To center the dowels, set the device to straddle each board's edge and squeeze the parallelogram shut. Then slide the device to each mark and drill.
—John Huening, Seffner, Fla.

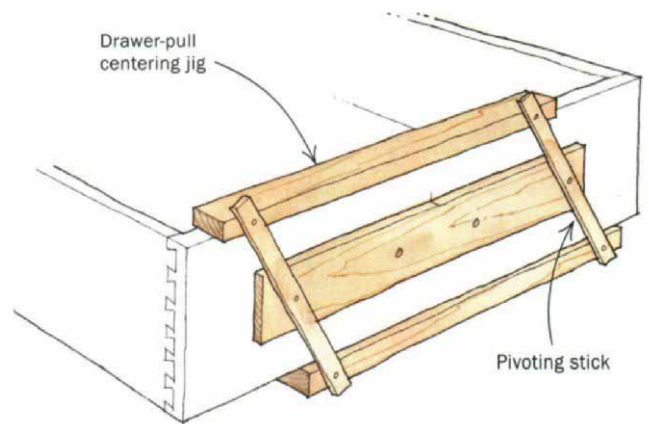

FWW#43 Shown above is a self-centering jig for boring drawer-pull holes. The pivoting sticks should be made long enough to span your deepest drawer. The center plate may be fitted with drill-bit guide bushings or just small holes for marking with an awl.
—J.B. Small, Newville, Pa.

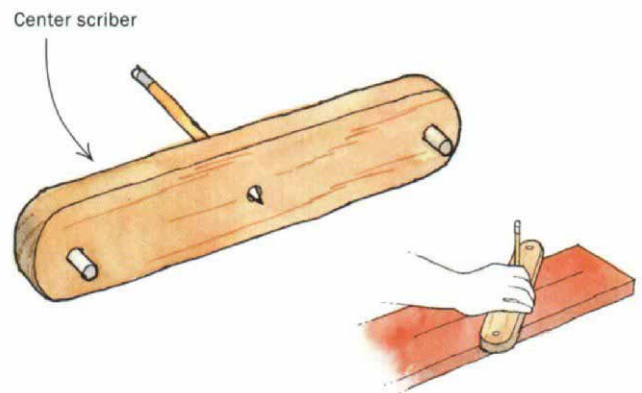

FWW#43 This old-time gadget is handy for center-scribing boards. Install dowel pegs at the ends of the device and drill a hole in the center for a pencil point.
—Larry Green, Bethel, Conn.

Multiuse bandsaw auxiliary table

FWW#98 Ripping and resawing on the bandsaw is always a problem because of the natural tendency of each blade to lead the cut in a slightly different direction. The traditional method of compensation is to find the lead angle, mark a line on the table and then clamp a makeshift fence parallel to this line. The auxiliary table shown in the drawing on p. 32 improves on that solution by borrowing your tablesaw's miter gauge for ripping as well as crosscutting on your bandsaw.

I made my auxiliary table from a discarded laminated kitchen countertop, but a good grade of plywood would work just as well. Size it a little larger than the original table, then drill through both tables and fasten them together with four countersunk carriage bolts. Cut a slot for blade entry. Now cut two $\frac{3}{4}$ -in. dados to fit the miter gauge. Cut one parallel to the blade for standard crosscutting

Methods of Work (continued)

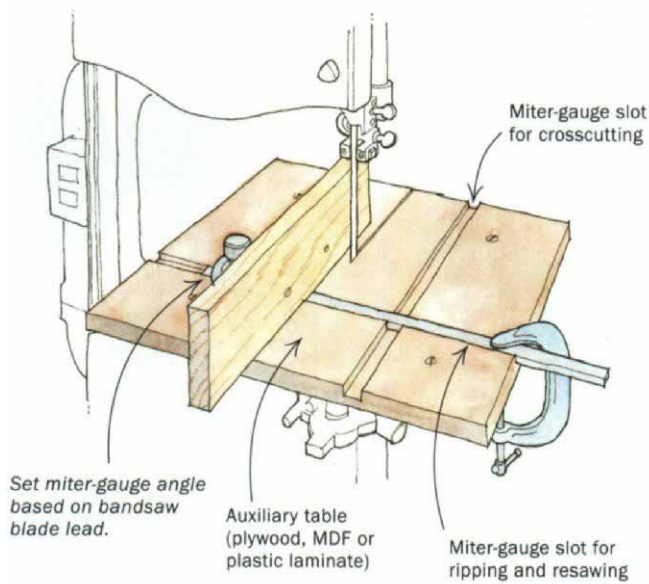

operations and then a second dado at a 90° angle to the first for ripping and resawing.

To find a blade's lead angle, mark a centerline on a piece of 1x2 scrap stock. Carefully rip freehand along this line until the stock reaches the rear of the table. Leave the 1x2 in this position and insert the miter gauge in the second slot as shown. Loosen the protractor adjustment knob and slide the miter gauge up to the workpiece. Adjust the fence angle to the lead angle you just found, then tighten the protractor knob. Remove the 1x2, position the miter gauge for the desired cut width, measuring from the front of the blade, and clamp the gauge in place. You're now set up for accurate, repeatable ripping and resawing.

—Anthony P. Matlosz, Howel, N.J.

Masking-tape drill stop

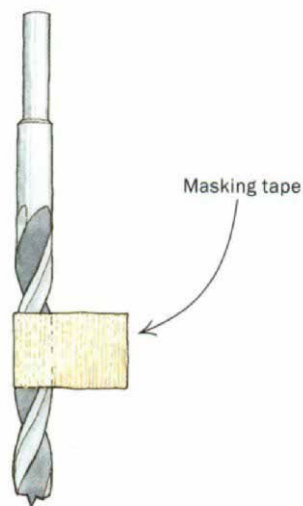

FWW#46 The best depth stop for a portable electric drill is a masking-tape flag around the bit stem, as shown in the drawing.

Masking tape works on all kinds of bits, is easy to set to the right depth and never mars the workpiece. The advantage of the flag is that you don't have to strain your eyes to tell when the tape reaches the surface: You simply stop drilling when the flag sweeps the chips away.

—Richard R. Krueger, Seattle, Wash.,
and Norman Crowfoot, Pinetop, Ariz.

Improved featherboard

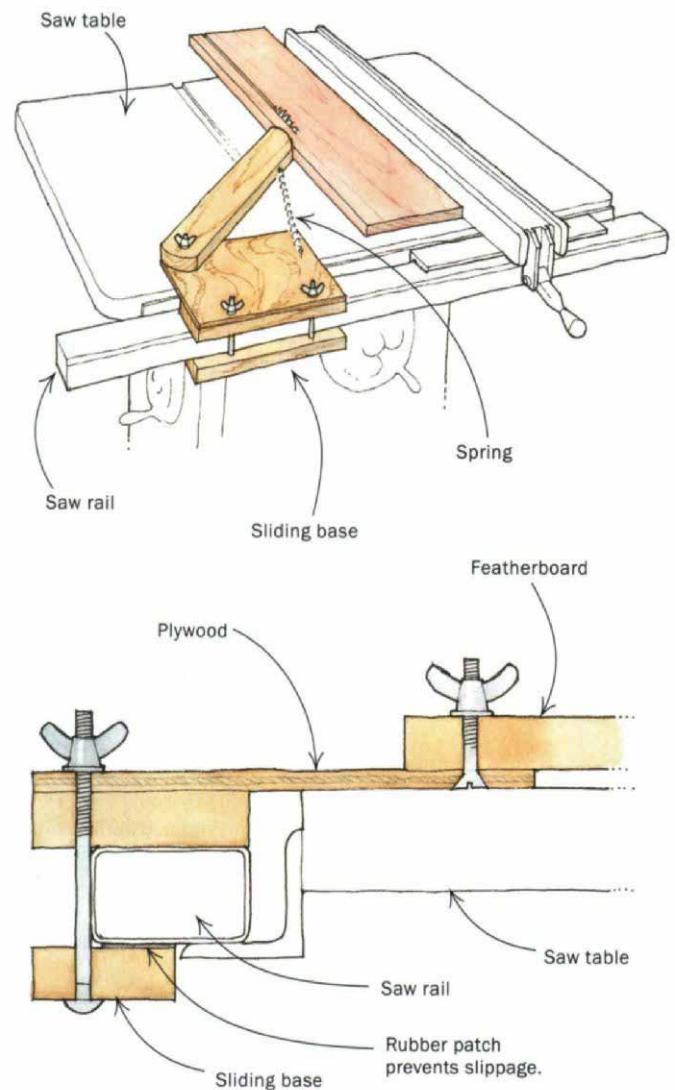

FWW#55 I finally got tired of the clumsy business of clamping a featherboard to the saw table and then tediously reclamping it each time to adjust it to the width of a new workpiece. The simple solution shown above took less than an hour to make and works perfectly.

It consists of two parts, a featherboard and a sliding base. The featherboard pivots on a bolt and is kept in tension against the workpiece by a spring. Custom-fit the sliding base to your front fence rail so that it can move anywhere along the front edge of the saw table and be locked in place with wing nuts or wedges. A

Methods of Work (continued)

patch of rubber on the bottom piece will help keep the sliding base from slipping.
—Arthur Kay, Tucson, Ariz.

Router mortising jig

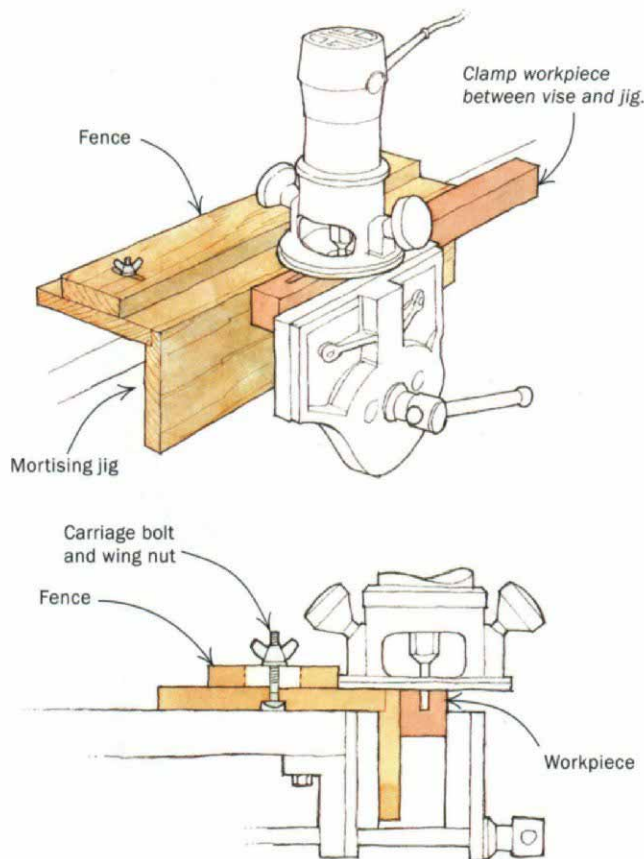

FWW#120 With this simple jig and plunge router, you can rout mortises or panel grooves in any size leg or rail. The work is held between the jig and your bench vise, clamped flush with the surface of the jig. The jig provides a stable base for the router. Adjust the fence back or forth to orient the router cut to the workpiece. For longer pieces, make a longer jig, and clamp the workpiece at each end.
—Anthony Guidice, St. Louis, Mo.

Carriage for milling wood on the bandsaw

FWW#84 I'm always looking for interesting hardwood scraps, split firewood and small logs for turning blocks. But hand-feeding the irregular shapes through the bandsaw to cut them into usable pieces isn't safe. I developed a solution based on my recollections of a rolling log carriage used in sawmills. I used the same basic idea but scaled down the carriage.

I mounted a 3-ft.-long pipe clamp to a 2-ft.-long U-shaped maple bracket, as shown in the drawing above right. To allow lateral adjustment, I slotted the bracket's bottom and fastened it to the base with bolts and wing nuts. A maple track glued to the bottom of the base slides in the saw's miter-gauge slot. When making the carriage, be sure the clamp jaws clear the bandsaw blade with the

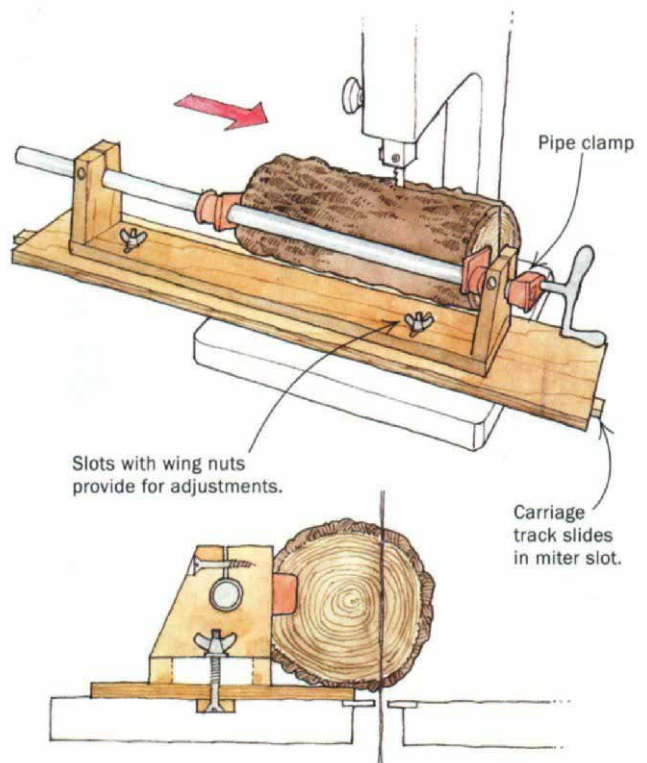

bracket at its closest setting. To use the carriage, tighten the log in the clamp, adjust the bracket for the width of cut and feed the log past the blade.
—E.G. Lincoln, Parsippany, N.J.

Long-lived sanding strips

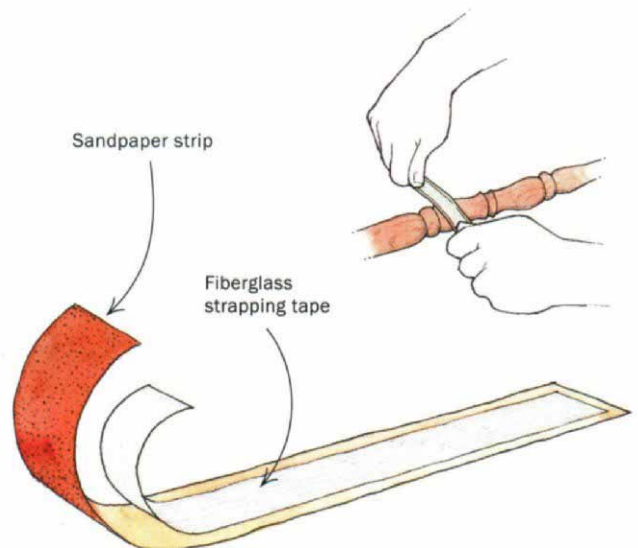

FWW#18 Narrow strips of sandpaper that are used to sand turnings or curved objects tend to tear, cutting less efficiently the shorter they get, until they are so many useless pieces of expensive

Methods of Work (continued)

paper. To make them last longer, back them with fiberglass strap-ping tape; they'll be virtually untearable.

—J.S. Gerhsey, Lake Ariel, Pa.

Improved tapering jig

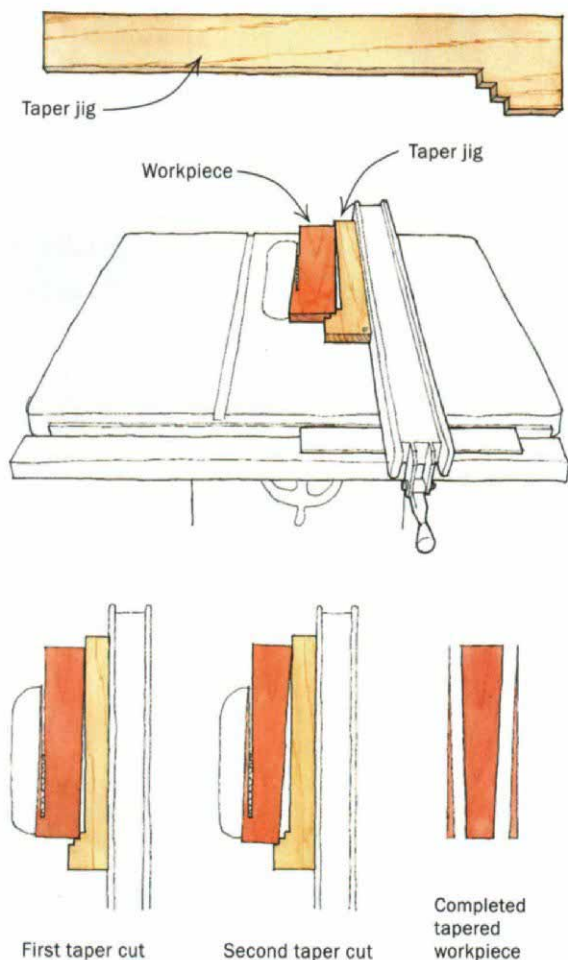

FWW#102 The tapering jig I use for short runs is just as quick to make as Phil Clark's (*FWW#98*, p. 20), but it also handles longer workpieces and provides more control and safety.

I simply cut three notches into a scrap piece that's 6 in. or so longer than the workpiece to be tapered, as shown in the drawings above. The width of each notch is one-half the taper. For longer runs or if the final taper is too small to hold securely and safely, I attach the jig to a substrate and use De-Sta-Co toggle clamps to hold the workpiece firmly.

—Tai Lake, Holualoa, Hawaii

Bench clamping with hand screws—two methods

FWW#88 Here's a make-do vise I set up until I have the time to build a proper woodworker's bench with a built-in vise (see the top drawing at right). Simply clamp one hand screw to the corner of a sturdy table with another hand screw. The bigger the hand screws, the better. This temporary arrangement produces

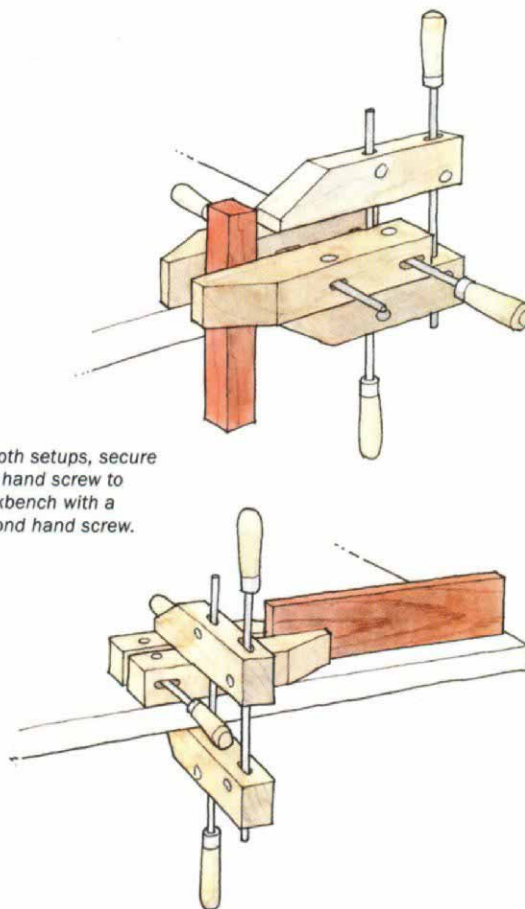

a more than satisfactory substitute bench vise. For a more permanent solution, you could secure the hand screw directly to the tabletop with a lag screw. Recently I used this setup to support doors while I planed them to final dimensions.

—Jonathan Percy, Newport, R.I.

FWW#106 The workbench I am building doesn't have a vise yet. As an interim solution, I use two large hand screws. I lay the first clamp horizontally on the bench to hold the work. Then I clamp the first clamp to the bench lip with the second clamp, as shown in the bottom drawing above. This arrangement has the advantages of being cheap, movable, strong and versatile.

—Thomas Grace, Binghamton, N.Y.

Extension fence helps straighten crooked stock

FWW#115 I put off building one of those carriage fixtures for straightening crooked-edged boards on the table saw for several years. The fixtures require expensive hold-down clamps, and they reduce the possible depth of cut by holding the workpiece off the saw table. The real problem was that the length of the regular rip fence is too short.

Then I noticed an 8-ft.-long piece of aluminum channel leaning in the corner of my shop. I clamped the channel to the rip fence, as shown in the drawing on p. 38, to produce an auxiliary fence

Methods of Work (continued)

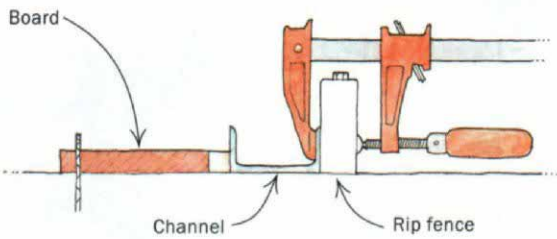
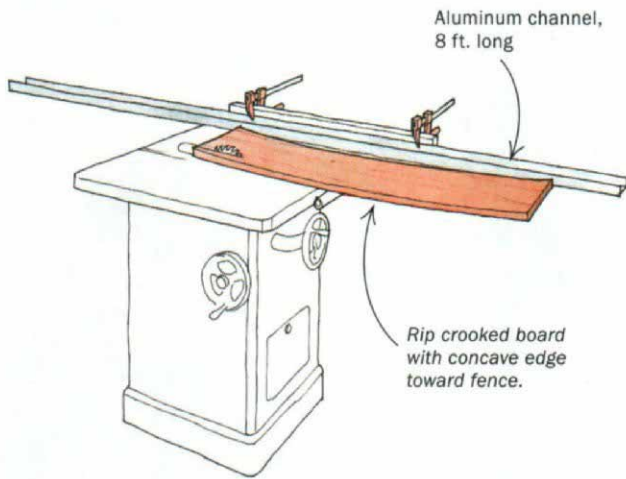

that would guide fairly long stock in a straight line. To use the auxiliary fence, I just put the concave side of the board against the long fence and push it through. It works.

—William Mondt, San Diego, Calif.

Less is more

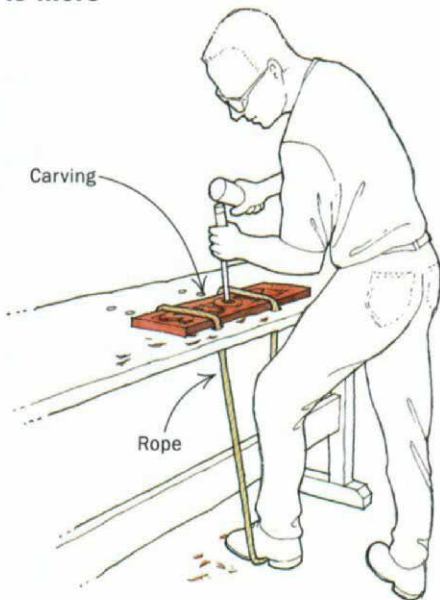

FWW#14 I have any number of expensive, cumbersome, time-consuming hold-down clamps for carving, but this rig beats them

all. I discovered it while visiting China last summer. It's an easy way to hold down a workpiece that has to be moved frequently, for carving and fine work. —W.D. Young, Scotch Plains, N.J.

Wall-mounting cabinets

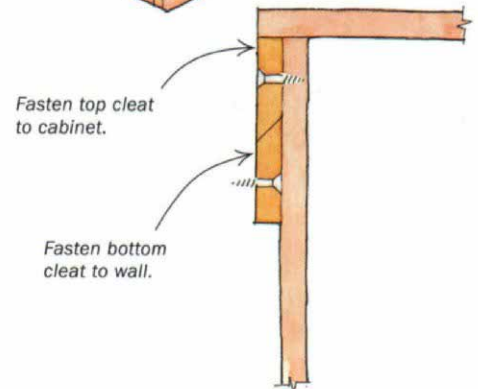
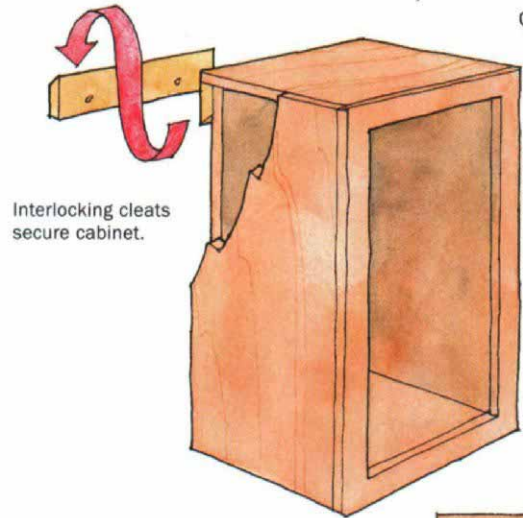
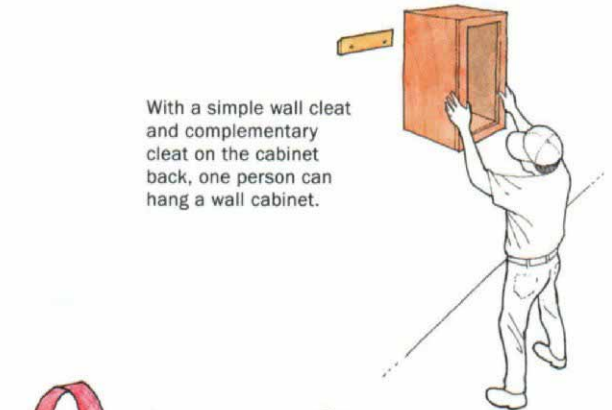

FWW#48 This simple method for hanging wall cabinets is fast, easy and accurate. Rip a $\frac{3}{4}$ -in.-thick board in two at a 45° angle. Screw one cleat to the wall to form a perch and the other cleat to the cabinet back, which should be recessed $\frac{3}{4}$ in., as shown. Then just slip the cabinet over the wall cleat—a one-man operation. As a bonus, the cabinet can easily be removed whenever needed.

—George C. Muller, Union, N.J.

Methods of Work

EDITED AND DRAWN BY JIM RICHEY

Shopmade sliding crosscut table

Most woodworkers appreciate the performance and accuracy that a sliding table would lend to their tablesaw, especially one with enough capacity to crosscut a full sheet of plywood. But for most of us, the costs in dollars and valuable floor space make such a piece of equipment prohibitive. Addressing those concerns, I de-

vised to make my own sliding table based on the principle of a heavy-duty full-extension drawer slide. For everyday use, the extension table is locked onto the base and doesn't take up any extra floor space in front of the saw. But when I release a small lever, I can pull back the extension table to make a 49-in. opening and crosscut a full sheet of plywood.

The table consists of four main parts: the base, the extension table, the traveling carriage and the worktable. Start by constructing the base and the extension table of $\frac{3}{4}$ -in. plywood. Rout a cove into the edges of these two pieces to accept lengths of electrical metallic tubing, which become the rails for the traveling carriage.

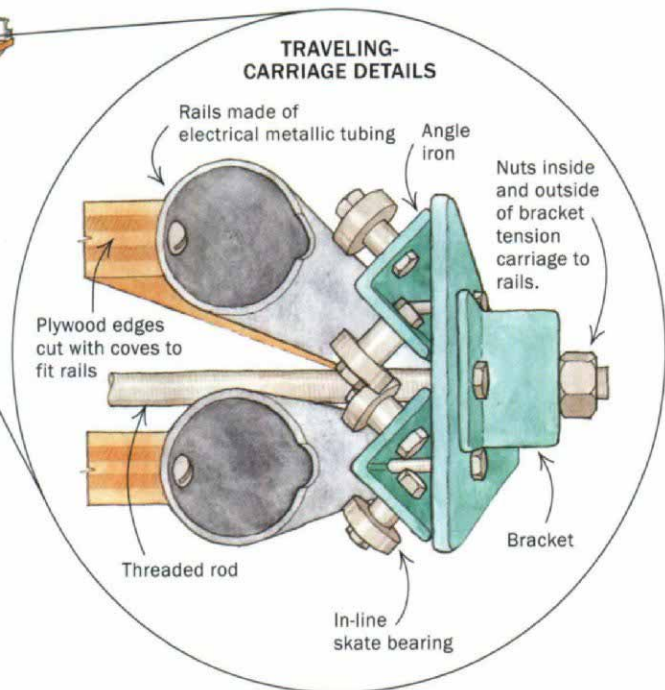
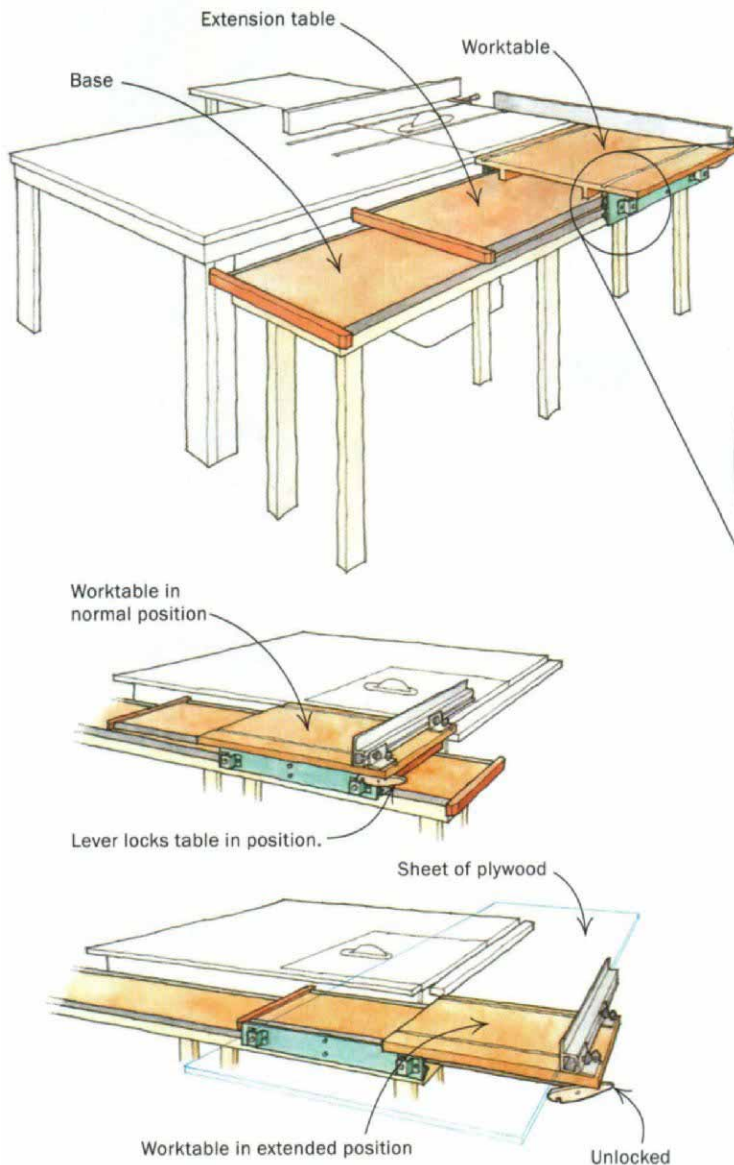

Make the traveling carriage from two pieces of 4-in. flat steel plate with two pieces of angle iron bolted along each top and bottom edge to hold the in-line skate bearings that provide the rolling action. These two steel-plate assemblies are held together and tensioned by means of two threaded rods that pass between the base and the extension table, and they're locked in place by nuts inside and outside the metal brackets on each end of the carriage. Screw the worktable to the extension table using two spacers so that the worktable clears the traveling carriage. I added aluminum T-slots in the top of my worktable so that I can angle the fence in relation to the blade.

—Jack Hegarty, Tottinham, Ont, Canada

continued on p. 16

A reward for the best tip

Jack Hegarty won an engraved Lie-Nielsen handplane for his winning tip about making a sliding panel attachment for his tablesaw. Hegarty took up woodworking as a hobby 25 years ago, and he spends most of his efforts building antique reproductions for his family. The machinist's talents required for his daytime job (keeping the equipment humming for a large Canadian oil company) are evident in the design and execution of his sliding table. Send us your best tip, along with any photos or sketches (we'll redraw them) to *Methods of Work*, Fine Woodworking, P.O. Box 5506, Newtown, CT06470-5506.

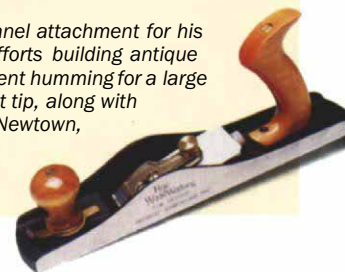

Methods of Work (continued)

Router guide for convex curves

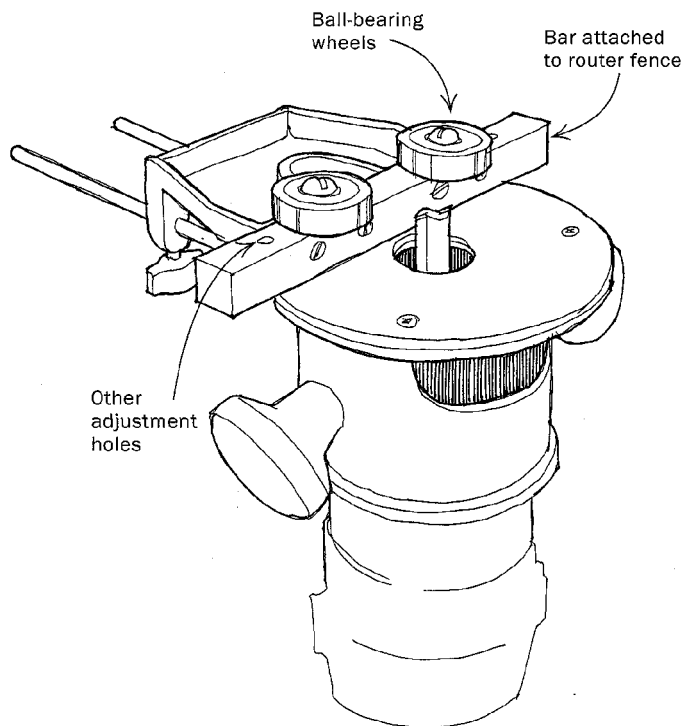

I just finished a job that required routing dados, veining and edging on large circular and semicircular shapes. The standard router edge guide is useless in these situations. So I modified the guide by adding two ball-bearing wheels as shown above, and now the guide follows circular shapes quite well. I drilled other adjustment holes to attach the bearings so that I can work on a wide range of circles with different radii. —David Noble, Wilmington, N.C.

Quick tip: Procter & Gamble's disposable refill cloths for the Swiffer dust sweeper make excellent tack cloths. The cloths do a great job of removing wood and sanding dust and do not interfere with subsequent finishes. They are relatively inexpensive and can be used repeatedly. —Paul L. Stotler, Leonardtown, Md.

Guide blocks for hand-cut dovetails

These simple dovetail guide blocks (above right) cost nothing, are quick to make and are quite helpful for marking, cutting and paring hand dovetails. Start by ripping a 1¾-in. square hardwood block at least 12 in. long. Rabbet one corner of the block to the thickness of your dovetail stock, or (if you like your pins and tails to protrude slightly to allow trimming later) just a shade deeper.

Set your chopsaw to the desired dovetail angle and cut one end of the guide block to that angle. Flip the block 180° and cut off a piece of the block about 2 in. long. This piece is your first layout and cutting guide. Once again, flip the block 180° and cut off another piece about 2 in. long. This is your second layout and cutting guide. Square off the ends of the rest of the block to use as a chisel guide.

Use the two angled blocks to scribe the dovetail pins (or tails, depending on which you mark first). If one angled block won't

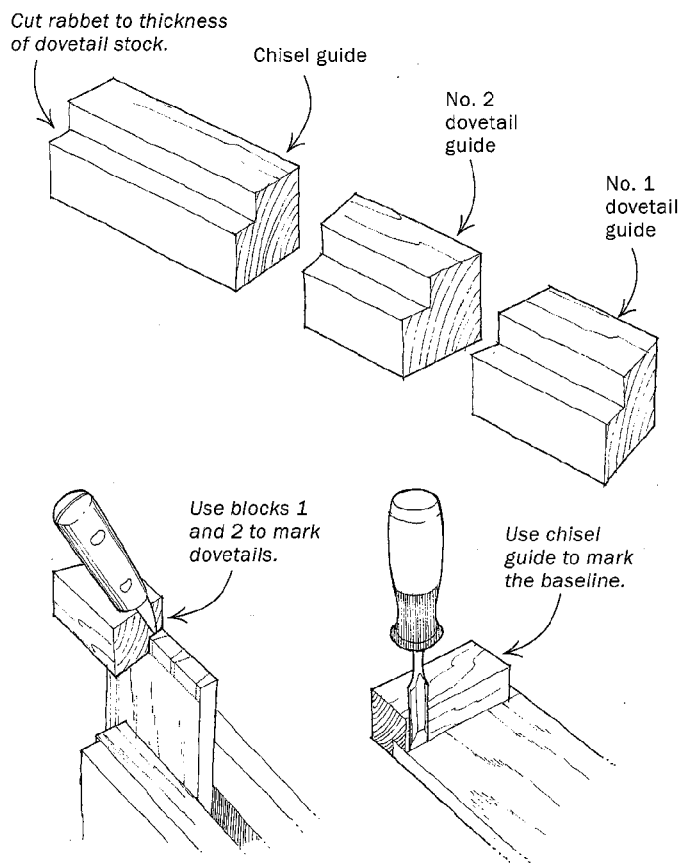

work, the other one will. After you have scribed the location of the pins, clamp or hold the appropriate block in place to guide your handsaw at the correct angle.

Use the third block to mark the depth of the baseline of the pins and tails. You can also use the third block as a chisel guide. Simply clamp it to the workpiece and press the flat of your chisel against it for the first tap.

With these guides your dovetail joints should fit perfectly. But if they don't, you can also use the blocks as a guide for paring the pins or tails with a chisel. —Glenn Crocker, Huntsville, Ala.

Quick tip: Rubber bulb syringes—the long-snouted, teardrop-shaped squeeze bulbs made for cleaning the nostrils of babies—work well in the shop to blow chips and dust from mortises, inside corners and other hard-to-reach places. The syringes are available in drug stores. —James F. Leach, Clifton Park, N.Y.

Hole-boring jig for angled spindle mortises

Recently I built a spindle-sided cradle with angled sides and ends. This type of construction requires that each spindle mortise be bored at a slightly different angle. Not trusting my eye to drill each mortise by hand, I built a simple but useful drill-press jig to accomplish the job accurately and quickly. The jig, built of ¾-in.-thick medium-density fiberboard (MDF), consists of an L-shaped base that clamps to the drill-press table and an inverted L-shaped pivoting fence for holding the workpiece. The pivoting fence should be a couple of inches shorter than the base. To make the

Methods of Work (continued)

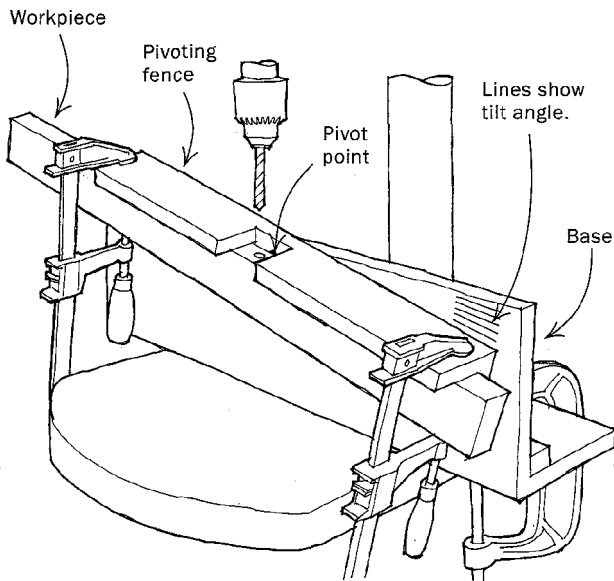

jig, construct the two L-shaped pieces, then drill pivot holes in both the vertical plate of the base and the fence. Drill the pivot hole in the fence right at the joint of the pieces forming the inside of the L-shape. Mount the fence to the base with a 1/4-in. counter-sunk stove bolt. By mounting the pivoting fence as an inverted L and clamping the workpiece to the underside of the short leg, you can set the mortise depth, and it will remain the same for all mortises, regardless of the angle of the bore.

To use this jig, simply clamp the workpiece to the underside of the pivoting fence, rotate the fence to the correct angle and drill. Because the fence is shorter than the base, you can mark all of the reference angles for the mortises to be bored. Where each mortise angle is different, I usually just hold the pivot angle by hand. But for repeated mortises at the same setting, it is best to clamp the fence to the base at one end. —Richard Brening, Bellevue, Wash.

Quick tip: To keep brushes from drying out, place the brush inside a slide-lock plastic bag and snug up the slide on the brush handle. The bag will keep the brush from drying out for several days.

—John Martin, Racine, Wis.

Approximate ellipse is easier to cut

I've seen lots of complicated methods for laying out an ellipse. Here's a method for drawing a curve that closely approximates an ellipse. The advantage is that you can cut this curve with a simple pivoting jig.

The method uses an old mechanical drafting technique that approximates an ellipse one quadrant at a time by using two circular arcs of different radii. The trick is to find the two radius points (A and B) of the two circular arcs. With a little trial and error you might be able to locate them freehand.

But for the more mathematically inclined, there's a more precise method. First lay out the short (minor) and long (major) axes of one quadrant of the curve, and connect the end points of the axes to produce a right triangle. On the hypotenuse of this triangle, first mark the point *d*, which is the difference between the long and

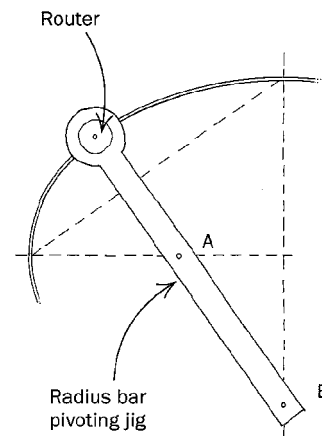
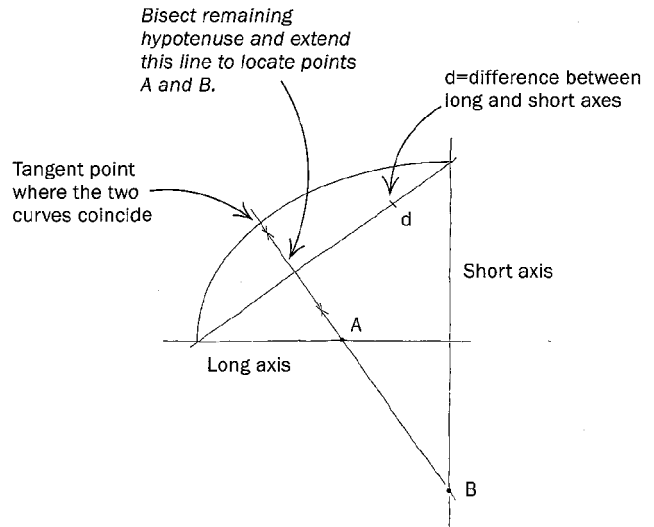

Cut this section using pivot point A.

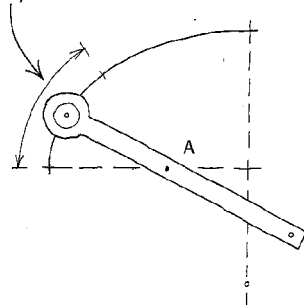

Cut this section using pivot point B.

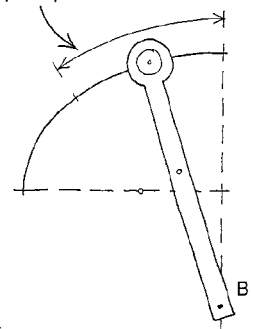

short axes. Bisect the remaining segment of the hypotenuse and extend the bisection line at 90° to the hypotenuse so that it intersects both the long axis at point A and the extension of the short axis at point B.

To cut the curves with a router, make a radius bar pivoting jig with two pivot points as shown above. With the bar pivoted at point A, swing the router to cut the left end of the curve. When the

Methods of Work (continued)

router reaches the tangent point where the two curves coincide, move the pivot point to B and cut the rest of the curve.

—Richard L. Smith, Silver Spring, Md.

Accurate adjustments on a router edge guide

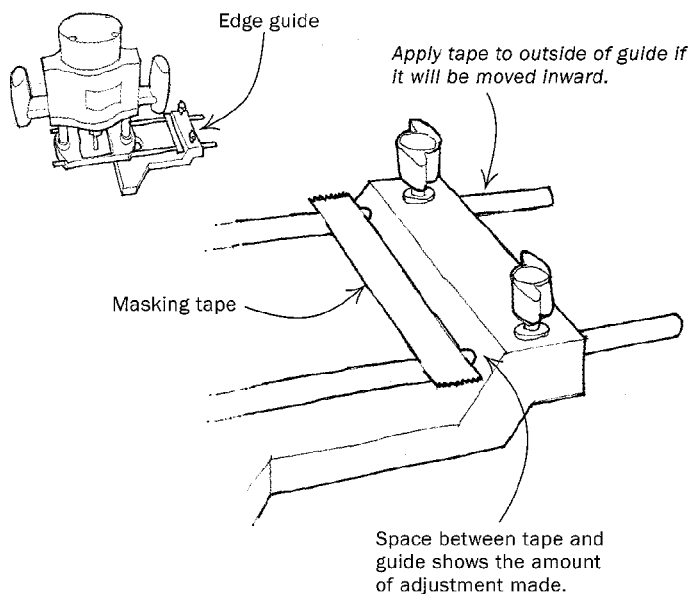

To make fine adjustments using a standard router edge guide, first make a test cut on scrap, then determine the amount of adjustment required. Apply a strip of masking tape across the steel rods flush with the edge guide, as shown in the drawing above. (Apply the tape on the outside of the guide, away from the router, if the guide will be moved inward, and on the inside if it will be adjusted outward.) Loosen the knobs, and adjust the guide. The distance between the tape and the edge guide is the degree of adjustment. Very small adjustments are easy to read.

—Anthony Guidice, St. Louis, Mo.

Taking apart a glue joint with heat

Let's face it. Sometimes we mess up and need to take apart a glue joint. As long as the original joint was glued up with hide glue or white or yellow PVA glue, you're in luck. When subjected to moisture or heat, these glues lose their grip in short order. This is good news if you want to make a repair.

You can use warm water to take apart a joint, but it's messy, and it raises the grain. Heat is the better choice, but don't whip out a blowtorch just yet. When using heat to pull apart a glue joint, it is important that you use a heat source that will create a strong, deep heat without burning the wood. To accomplish this, I use a 250-watt infrared heat lamp in a portable light fixture. You can buy these lamps at a good hardware store or restaurant supplier. Be sure to buy a fixture with a heavy porcelain socket capable of handling the wattage and the heat of the lamp. Chicken-coup lamps are a good choice.

Focus the lamp right over the glue joint. In just a few minutes the glue will soften and the joint will pull right apart. Be careful—the wood will be really hot. Instead of pulling apart the joint by hand, I use a quick clamp with the head reversed. I simply apply small

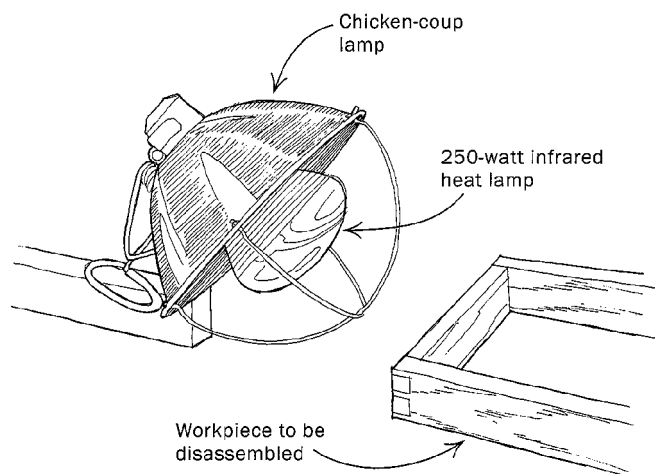

amounts of pressure until the joint comes apart. Denatured alcohol and a soft wire brush are all I need to clean off the old glue.

—Clay Baker, Woodside, Calif.

Lightweight sawhorses

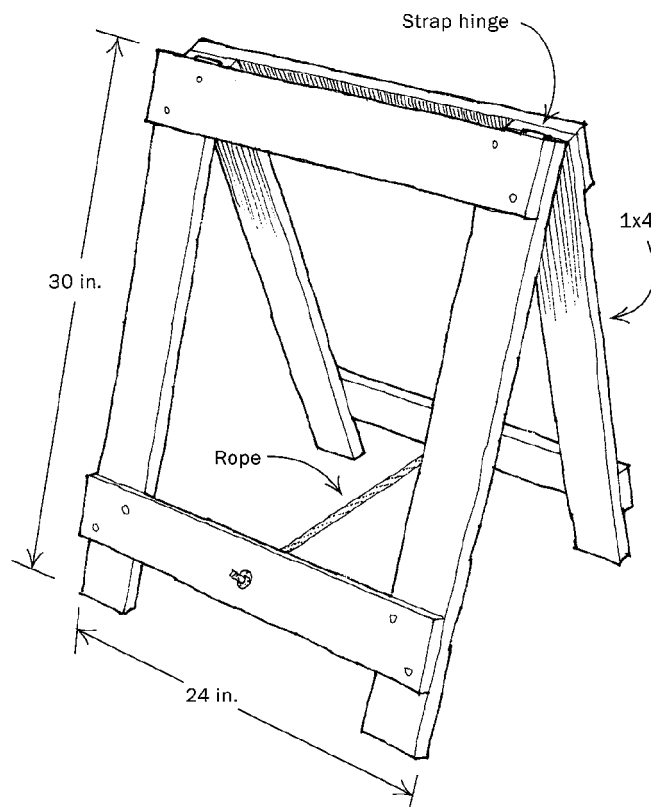

This sawhorse is light, strong and can be folded with one hand. It stores flat in your truck or against your shop wall. Best of all, it's cheap and easy to make. All you need are some 1 $\frac{1}{4}$ -in. drywall screws, a short length of rope, a couple of strap hinges and some scrap 1x4s. I've made horses of several sizes, but my favorite is the one shown in the drawing above.

—Bruce Schwarz, Manchester, Md.

Methods of Work

EDITED AND DRAWN BY JIM RICHEY

An easy method for drawing a golden rectangle

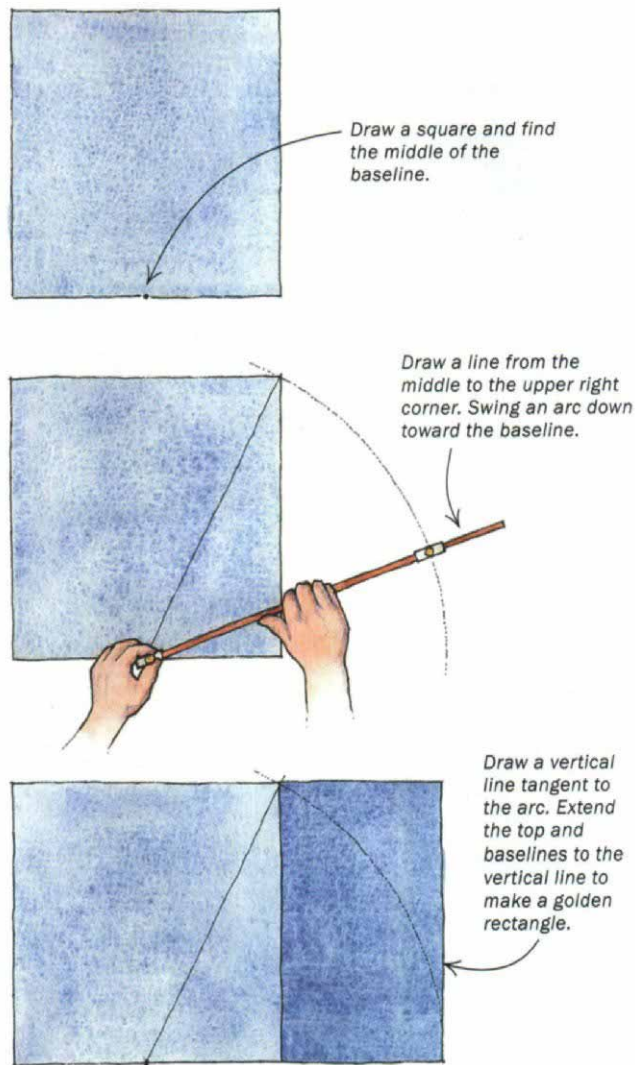

The proportions of a golden rectangle (in which the ratio of width-to-length is about 1:1.6) have long been regarded as pleasing to the eye. Golden rectangles were used extensively in Greek architecture and 18th-century furniture. It is generally agreed among designers and tradespeople who possess a discerning eye that a golden rectangle just looks good.

Learning to incorporate golden rectangles into your work can become quite complicated, but it doesn't have to be. Some wood-

workers and designers use a mathematical approximation of a golden rectangle, based on consecutive numbers from what is called the Fibonacci series. In a Fibonacci sequence (1, 1, 2, 3, 5, 8, 13, 21, 34 ...), each number is the sum of the two previous numbers, and the ratio between any two consecutive numbers averages out to about 1.6—the same number found in a golden rectangle.

As a high school math and woodshop teacher, I realized that by incorporating geometric construction into my woodworking designs, I could achieve the same results more simply. The advantage to the construction method outlined (see the drawings at left) is that all you need to make a golden rectangle is a square, a tape measure (or a compass, if you're more of a purist) and a pencil. Start by drawing a square, and you end up with both a large and a small golden rectangle. No complicated math is necessary if you use this simple technique.

—David Casey, Sebastopol, Calif.

Inexpensive shopmade clamps

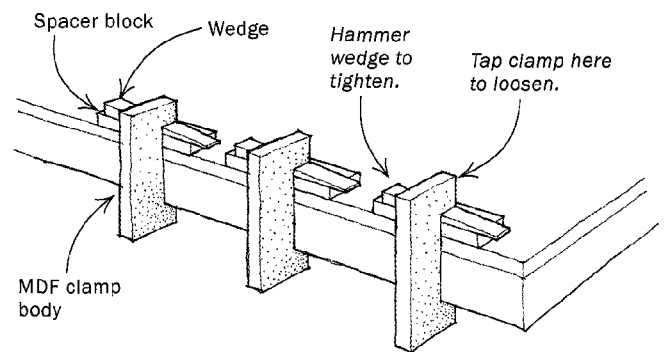

In the display business where I work, we never seem to have enough clamps. One day, after I ran out of clamps one too many times, I made a large number of the simple, wedge-activated clamps shown above.

I chose to make several sets of clamps in 3-in. increments, but you could make them in any sizes that you find handy. I wouldn't recommend using solid lumber because the grain will be weak at the inside corners, regardless of how you cut the clamp pattern from a board. Either medium-density fiberboard (MDF) or a good grade of plywood will be less likely to break.

Cut the wedges and the spacer blocks from hardwood. The wedge profiles should be sized for no more than 1 in. of thickness for every 6 in. of length. The spacer blocks (wider than they are thick) serve two purposes: They spread out the clamping force over a larger area, and they also act as space adjusters because they can be used either on edge or flat.

To use one of these clamps, simply find a combination of clamp, spacer and other material to make a tight fit for the wedge. Then



Our reward for the best tip

David Casey won an engraved Lie-Nielsen handplane for his winning tip about drawing golden rectangles. Casey has been teaching mathematics courses to high school students for 16 years. He's also worked for his father, a general contractor, every summer since he was 12 years old, so he's had plenty of opportunity to apply what he knows to real-world solutions. Send us your best tip, along with any photos or sketches (we'll redraw them) to *Methods of Work*, Fine Woodworking P.O. Box 5506, Newtown, CT 06470-5506.

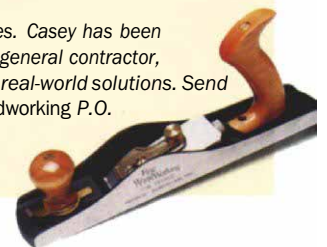

Methods of Work (continued)

pound the wedge into place. A simple tap on the downhill side of the clamp body will release it immediately.

I used scrap pieces of MDF to make the clamp bodies. But even if I cut the bodies out of a new sheet of MDF, the cost would be only about 10 cents each.

—Robert B. Chambers, Richardson, Texas

See-through rulers

Flexible ruler made from photocopied transparency film.

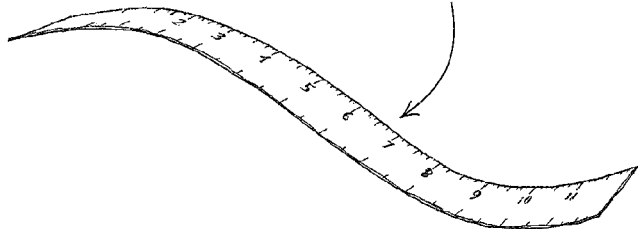

Clear, thin plastic rulers are handy because they don't obscure what you're measuring and can be wrapped around a curved surface. You can easily make one by photocopying your regular ruler on transparency film made for use in plain paper copiers. You can get a 12-in. ruler on regular letter-sized film by laying the ruler diagonally on the copier bed. Rulers that reproduce the best are those with a good contrast between the blade and the markings.

—R.B. Himes, Vienna, Ohio

Auxiliary work rest for large panels

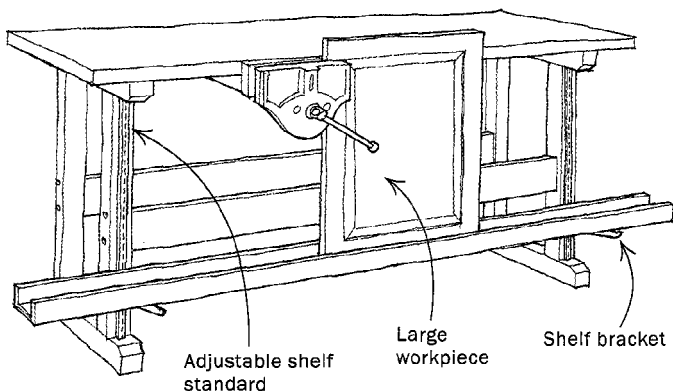

I attached metal shelf standards and brackets to the legs of my workbench. With the aid of a small shelf resting on the brackets, I can support large awkward workpieces, such as doors, at the right height for planing or installing hardware. I clamp one corner of the workpiece in my bench vise to hold the work steady and upright and add a pipe clamp to the other corner if needed.

—Roy H. Hoffman, Oriental, N.C.

Quick tip: To prevent glue squeeze-out problems when assembling drawers, simply finish the insides of the drawers before assembly. Sand all of the inside drawer parts and apply two or three coats of shellac, carefully avoiding the surfaces that will be glued.

Later, when you assemble the drawers, any bead of glue will pop right off after it has dried.

—Joe Barry, Lumberton, N. C.

Magnetic tack hammer

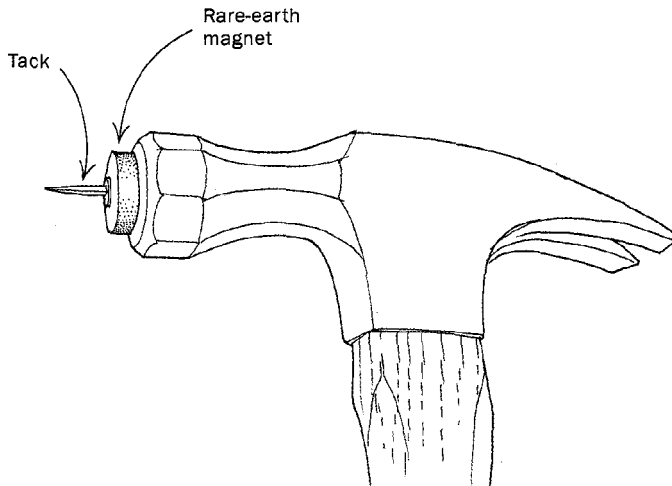

To turn any ordinary hammer into a magnetic tack hammer in seconds, simply place a rare-earth magnetic disc on the face of the hammer, place a tack on the magnet and tap the tack in position to get it started. Then remove the magnet or use a second hammer to drive the tack home. (You can buy magnets from Lee Valley Tools.)

—Leonard Feldberg, Chestnut Ridge, N.Y.

Ceiling-hung panel clamp

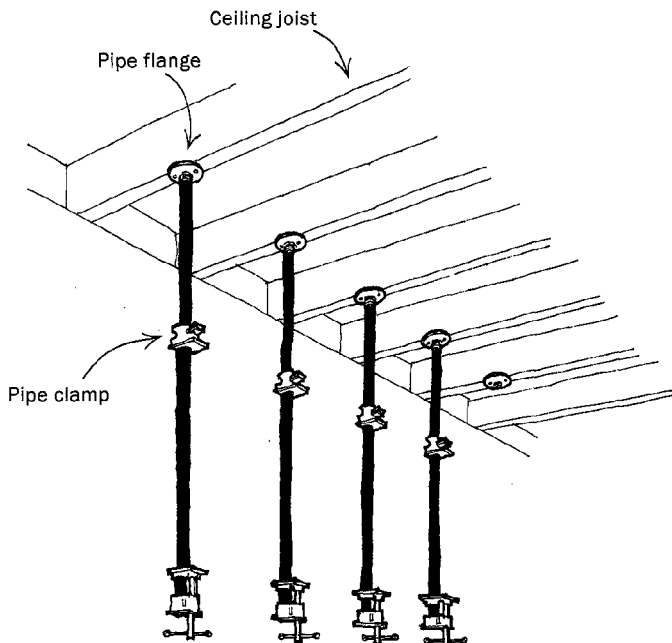

The frustrations of gluing up an unwieldy large face frame in my small basement shop prompted this idea for clamping up large panels. Attach $\frac{3}{4}$ -in. pipe flanges along a straight line to the shop's

Methods of Work (continued)

ceiling joists. When you're ready to glue up a panel, just screw in as many pipe clamps as needed. Having the clamps secured serves as a third hand—making it easier to load the workpieces and tighten the clamps. With the panel hanging vertically, you have ready access to both sides of your work, which makes adding more clamps and scraping excess glue a breeze.

—Jon Williams, Grants Pass, Ore.

Quick tip: The same rubber abrasive stick that you use to clean sanding discs and belts will also remove gum buildup from your bandsaw blade. Just push the stick against the sides of the blade while the saw is running. —Robert P. Cromwell, Royalston, Mass.

Shop-built bead scraper

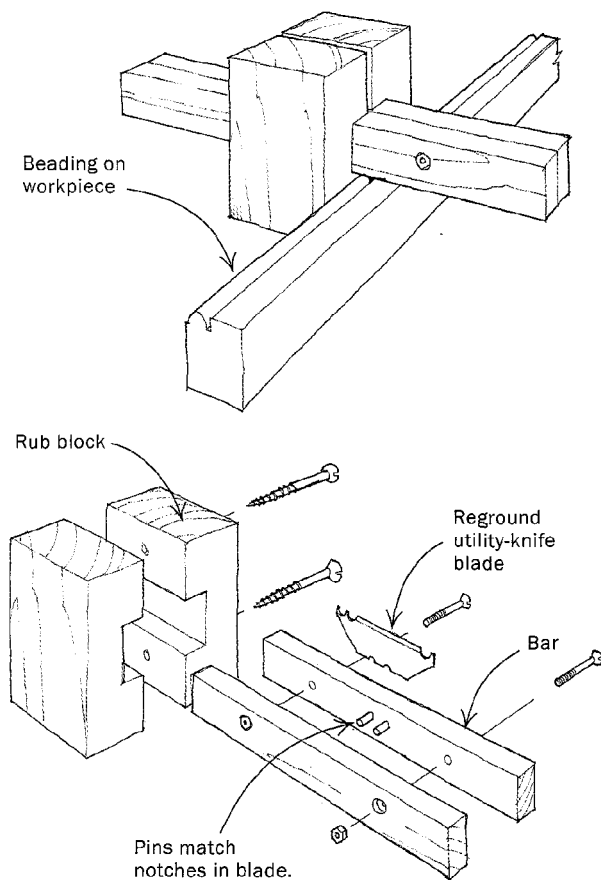

I use a shop-built scraper and recycled utility-knife blades to create decorative beads on furniture and trim, such as those often found around the faces of drawer fronts. The scraper consists of two oak parts: A two-piece bar that holds the blade in place and a sliding rub block that allows lateral adjustment of the blade. The bar is fitted with two brass pins that match the two $\frac{1}{8}$ -in. notches in the top of a utility-knife blade. Fixed against the brass pins, the blade does not move up or sideways when I apply pressure to scratch a bead.

To use the scraper, I first file the desired bead profile into the edge of a utility-knife blade. Then I install the blade in the bar, registering the notches in the top of the blade with the brass pins in

the bar. After tightening the blade in the bar with machine screws and nuts, I install the bar in the sliding rub block and lock the bar at the position desired with the pressure of two wood screws. I often cut a different profile at each end of the same blade and slide the block to one end or the other to use the desired profile.

—Jose L. Martinez, Niceville, Fla.

Pipe-clamp saddles from PVC pipe

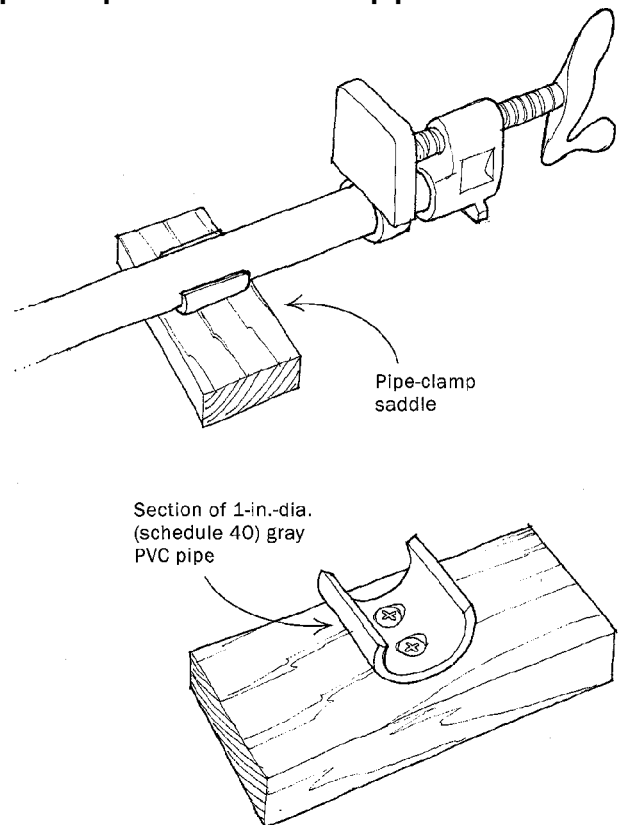

I always wanted several sets of pipe-clamp saddles but never wanted to pay 10 bucks a pair. When I discovered that 1-in.-dia. (schedule 40) gray PVC pipe snaps perfectly onto $\frac{3}{4}$ -in.-dia. iron pipe, I was able to make up all of the pipe-clamp saddles I needed for pennies each.

To make the saddles, cut a $1\frac{1}{4}$ -in.-long section of the 1-in. PVC pipe, then mark the centerline on the end of that section. Using a bandsaw, with the centerline as a guide, slice out a less-than-half section (about 150°) of the PVC pipe. This gives you a little more than a semicircle of conduit. The inside diameter of the PVC pipe is just a little smaller than the outside diameter of the $\frac{3}{4}$ -in. iron pipe, so it will snap onto the pipe firmly and won't slide around. Drill and countersink a couple of short drywall screws through the PVC section into a block of wood (as shown) to make a saddle.

You could also make a clamping jig by screwing several sections of the PVC saddles onto a longer piece of wood to space out your pipe clamps evenly. Or you could use the saddles to fasten your clamps into a storage rack. Because the saddles are made of PVC, it would be easy to glue them to each other or to other PVC materials to make an infinite variety of jigs. —Jim Foley, Mickleton, N.J.

Methods of Work

EDITED AND DRAWN BY JIM RICHEY

A safer stop block

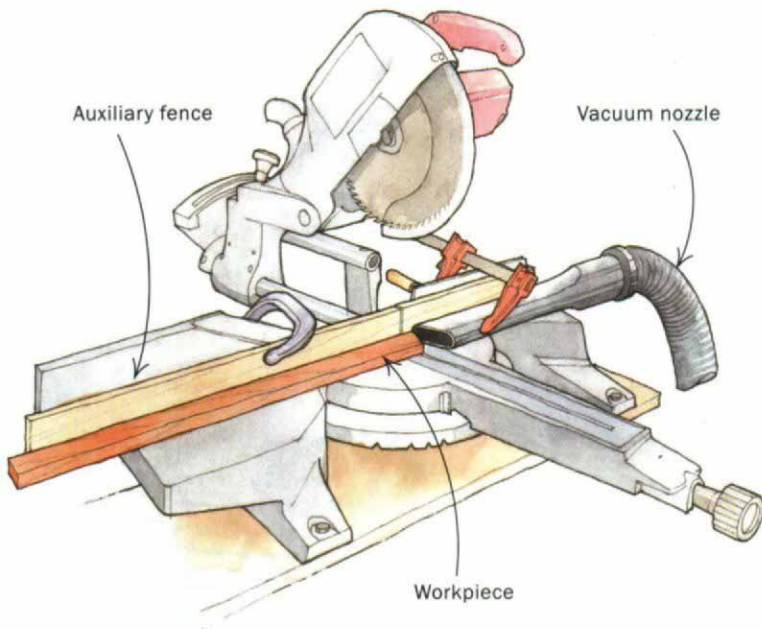

I enjoy turning bowls from segmented blanks that are glued up from many small identical pieces of wood. The problem with cutting these small segments on a chop saw is that many of the pieces will vibrate into the blade where they are either damaged or sent flying across the shop as dangerous projectiles.

My solution is to use the nozzle of a shop vacuum as a stop block. First, I clamp a 1/2-in.-thick auxiliary fence to the fence of my chop saw to create a zero-clearance fence. Then I tune the angled end of my vacuum nozzle on a belt sander to make the edges sharp and crisp. Next, I clamp the nozzle to the chop saw's fence at the correct distance from the blade, as shown above. After each cut the nozzle sucks up the potentially errant missile before it becomes airborne. Don't forget to empty the vacuum's dust bin before you begin, unless you enjoy looking for a wooden needle in a huge haystack of sawdust. —*Jim Vasi, Williamsville, N.Y.*

Making ring pulls

Here's how to make a trendy-looking ring pull from a harness ring and a cotter pin. Steel harness rings, sold at most hardware or farm-supply stores, are used for hitching lengths of rope and come in a variety of sizes. I use a #7, 1-in. ring for the pulls I make. This ring fits neatly within the eye of a 1/2-in. cotter pin.

I usually start by tarnishing the shiny finish to a gunmetal gray in a 24-hr. vinegar bath. You can add a bit of surface pitting to the

metal with a 24-hr. bath in household bleach prior to the vinegar bath, if that's the effect you want.

To make the pull, simply open the legs of the cotter pin, slip in the ring and squeeze the legs closed. You can attach the pull by pushing the pin through a hole, bending the protruding portion of

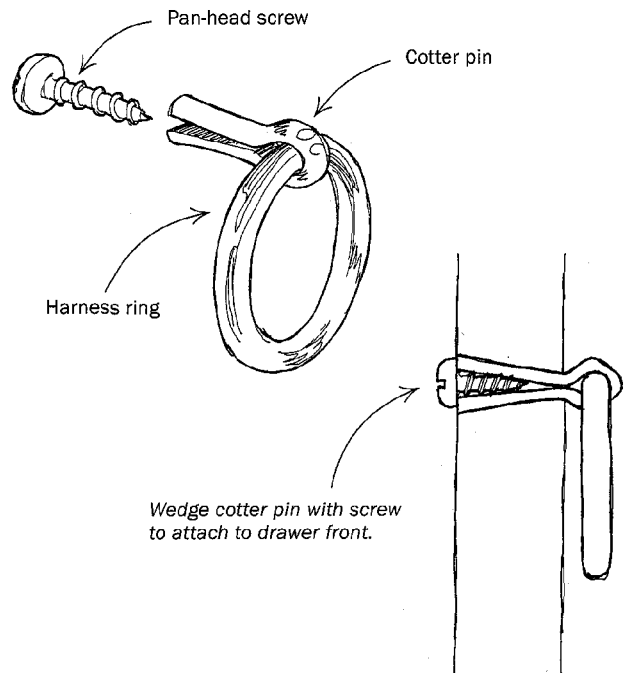

the legs into an L-shape and then hammering the legs, staplelike, into the back of the drawer front. But this looks pretty crude.

A more elegant way to fasten the pull is to cut off the legs 1/8 in. shy of protruding through the back. After drilling the hole for the pull, use the next-larger drill-bit size from the back to enlarge the back half of the hole into an oval shape from top to bottom. Insert the cotter pin into the hole and spread apart the legs. Then screw in a #6 pan-head sheet-metal screw between the two legs to wedge them apart and secure the pull.

—*David Gilmore, Maple Ridge, B. C., Canada*

Zero-clearance router-table fence

This zero-clearance fence is an easy project that improves the performance of almost any router bit. The fence is made of 1/2-in.-thick medium-density fiberboard (MDF). Construction details are shown in the drawing on p. 16. To use this setup with a new router bit, screw a new replaceable insert into the rabbeted recess in the

A reward for the best tip



Jim Vasi won an engraved Lie-Nielsen handplane for his winning tip on using a vacuum nozzle as a safer stop block. He recently retired after 36 years of teaching woodworking to high-school students. Vasi is president of the Western New York Woodturners, an organization consisting of 80 members. His specialty is making segmented bowls, which requires cutting and laminating hundreds of small pieces of wood. Send us your best tip, along with any photos or sketches (we'll redraw them) to *Methods of Work*, Fire Woodworking P.O. Box 5506 Newtown CT 06470-5506.

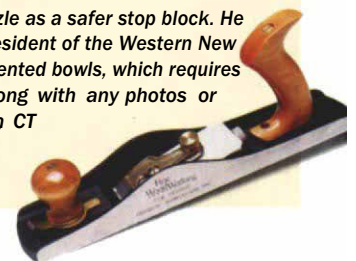

Methods of Work (continued)

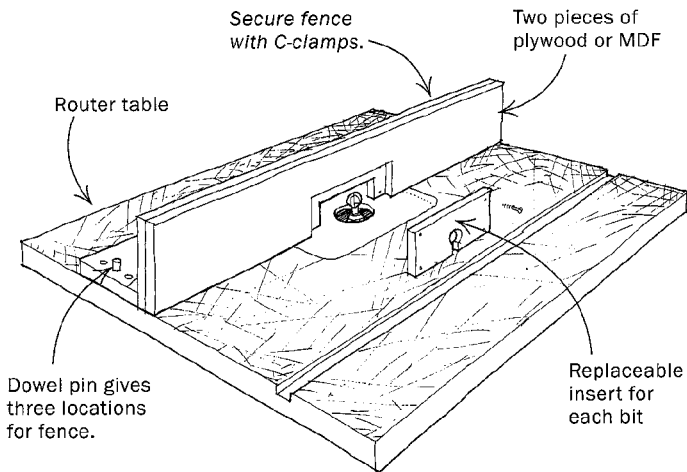

fence. Place the pivoting end of the fence over a dowel in the router-table top, turn on the router and swing the fence slowly through the bit to cut a reverse opening in the insert. The final placement of the fence is secured with two C-clamps. When you change the bit, you will need to install a new insert and repeat the operation.

—Ernie Conover, Parkman, Ohio

Quick tip: When using a scraper, swipe the edge of it along a block of paraffin after every few strokes. The paraffin lubricates the cutting edge, reducing chatter and preserving the sharp edge.

—Mike Zaslav, Cherry Hill, N.J.

In-floor dust-collection systems

Editor's note: Both of the following submissions are in response to a *Method of Work* by Bob Chandler (FWW #140, p. 24).

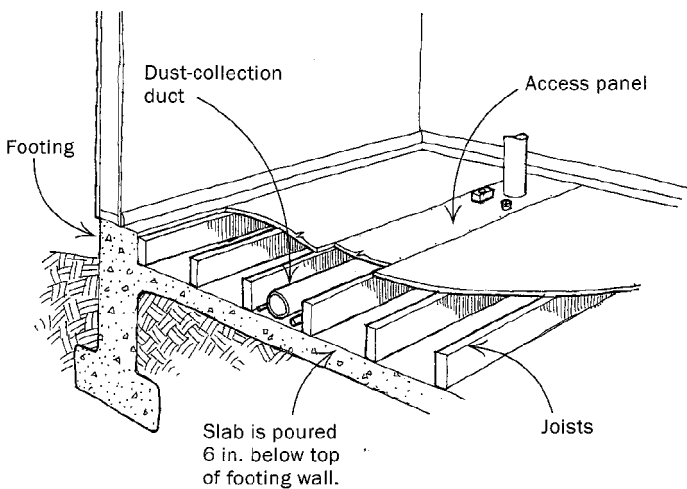

When I built my shop several years ago, I too didn't want to stumble over air hoses, dust-collection ducts or electrical cables on the floor. My solution was to have the contractor drop the cement floor 6 in. below the top of the footings. I then put in 2x6 joists and ¾-in. flooring to bring up the floor to the top of the footings. This

allowed me to put all of the hoses, wires and ducts under the floor between the joists. In addition, this also gave me a wood floor to work on, which is much easier on legs and dropped tools.

—Howard L. Althouse, St. George, Utah

For our new shop we designed a dust-collection system that rests on top of the concrete pad and between the 2x6 floor joists that support a ¾-in. plywood floor. The floor joists are 12 in. o.c, creating a channel that is deep and wide enough to house a 4-in.-dia. PVC dust-collection pipe, a compressed-air hose and electrical cables for floor outlets. The channel is topped off with an access panel. We also ran dust collection to the workbench, a very practical added feature.

—Julie Whittaker, Charlevoix, Mich.

Tablesaw switch stick

Tablesaw switch stick

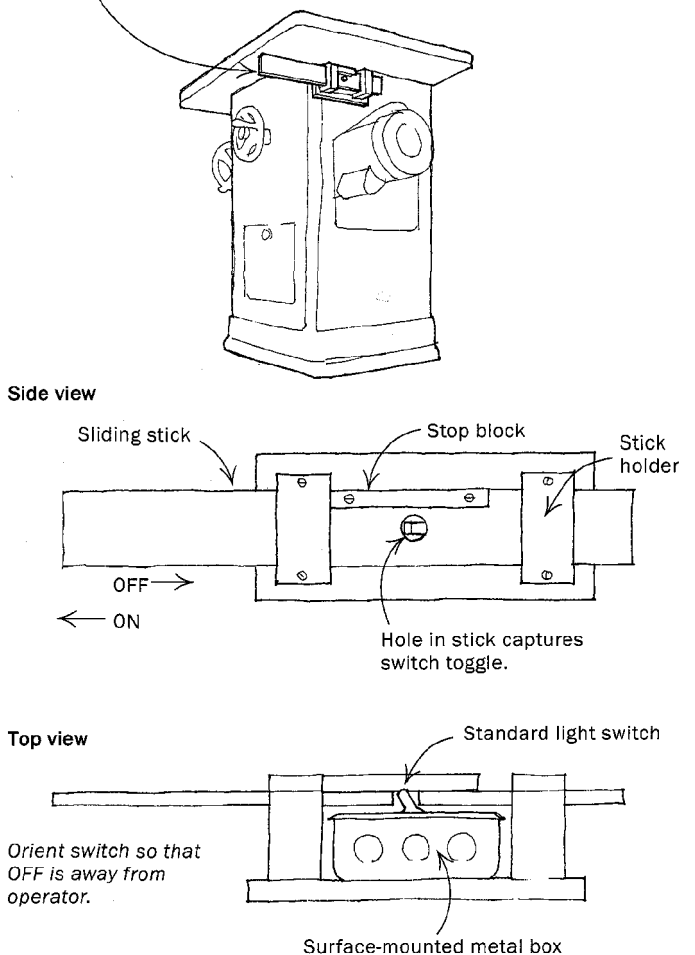

Jamie Buxton's safer tablesaw switch (FWW#139, p. 18) is an excellent innovation. But for those of us who are puzzled and discouraged by the gizmos and circuitry, here is a simpler option that has performed well on my tablesaw for several years.

Mount a scrap of plywood to your saw in a location that is convenient to access by hand or a bump with your body. To the

Methods of Work (continued)

plywood mount a common light switch in a metal surface box, oriented with the *on* toward the operator and the *off* away from the operator. Make a stick with a hole in it to fit over the toggle and extend the switch stick forward of the table. Pull the stick to start, push the stick to stop. Construct a simple stick holder that not only allows free back-and-forth movement but that also keeps your switch stick in place.

—Steven Stroh, Indianola, Iowa

Quick tip: Compact discs make excellent shims for setting up dado blades. Simply enlarge the hole to your arbor size and insert the discs between the blades to the required thickness. If a disc breaks, take heart: A replacement will arrive shortly in the mail from an Internet service provider.

—Tom Carpenter, Vernon, B. C., Canada

Bullet catch improves benchdogs

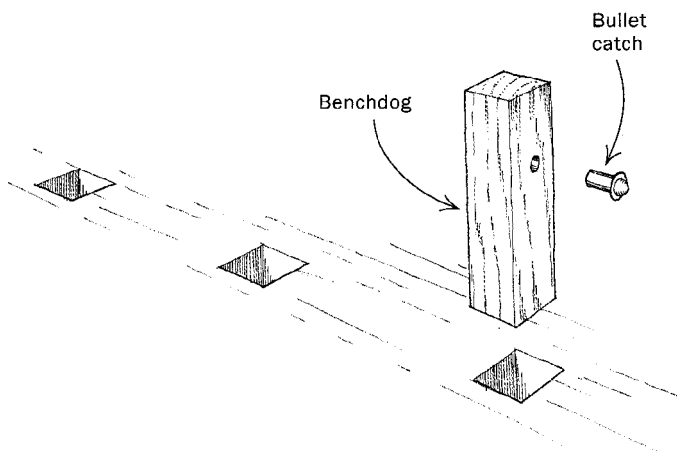

I install a small bullet catch in all of my wood benchdogs. The spring-loaded pin provides enough friction to hold the benchdog at just about any desired height. Just push or pull it into place, and it will stay put. I have used bullet-catch pins in several types of benchdogs, both square and round. It's a simple idea that works very well.

—Mike Griffin, Indianapolis, Ind.

Quick tip: To locate the correct Alien wrenches quickly and easily, wrap a different color of electrical tape around the handle of each wrench. Also, paint a dab of paint on each tool with a color that matches the tape on the Alien wrench used to adjust that tool.

—Jim Wheeler, Plainfield, Ind.

Mortise-and-tenon tips

Here are three techniques I use to improve mortise-and-tenon joints. First of all, pare out a slight reverse chamfer on the lip of the mortise before the first fitting. This prevents tearing out a chip of wood when a too-tight tenon is pulled back out of the mortise. The chamfer also creates a well for excess glue to prevent squeeze-out during glue-up.

Second, chamfer the end of the tenon. This makes the tenon easier to start into the mortise and also forms a well for excess glue at the bottom of the mortise. Third, undercut each shoulder of the

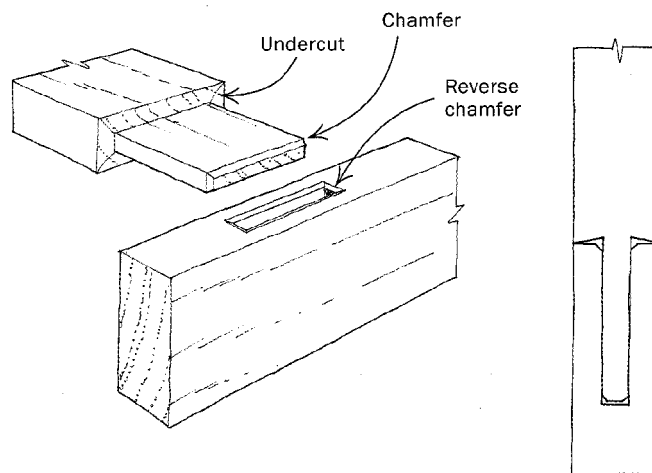

tenon slightly. This ensures a tight-fitting, no-gap joint and also helps—you guessed it—reduce glue squeeze-out.

—Michael Bakken, Fresno, Calif.

Pipe-clamp rack

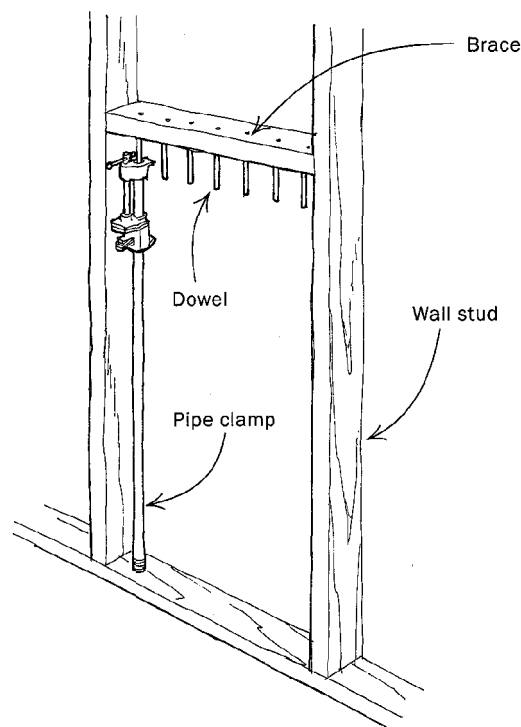

This pipe-clamp storage rack is a simple and easy answer for woodworkers with open stud walls in their shop. Make a horizontal brace to fit between two studs. Drill holes every 3 in. or so, and glue 2-in. long, 1/4-in.-dia. dowels into the holes. Attach the brace at the right height for your length of clamps. To store a clamp, simply slip the top end of the pipe onto a dowel and rest the bottom of the pipe on the floor plate. To remove a clamp, lift the pipe slightly and pull out the bottom at an angle.

—ChrisDiCiaccio, Gastonia, N.C.

Methods of Work

Upgrading a benchtop mortiser

The first year of using my benchtop hollow-chisel mortiser was an exercise in frustration. I found it hard to believe that a machine so simple and effective in concept could be so difficult to use. The biggest problem with the machine occurred when extracting the chisel. The hold-down did not lock the workpiece securely and thus caused the chisel to jam in the mortise. This happened more frequently with bits larger than $\frac{3}{8}$ in., and they became more difficult to free after making a plunge cut.

The jamming also revealed another problem—the inherent instability of the machine. When I attempted to free the chisel by pushing up the handle, the entire machine had a tendency to tip back. Clamping the machine to a workbench was impossible because there was no place to mount a clamp at the front of the machine. Also, the worktable was just too small to support the longer workpieces I was cutting.

After studying these problems, I came up with several upgrades.

The first thing I did was attach the mortiser to a permanent sub-platform made of two layers of laminated $\frac{3}{4}$ -in. plywood. The sub-platform raises the mortiser $1\frac{1}{2}$ in. off the benchtop and provides a lip at the front for clamping the unit securely to the benchtop.

Next I removed the small medium-density fiberboard (MDF) worktable that came with the machine and replaced it with a 10-in. by 24-in. aluminum plate, $\frac{1}{2}$ in. thick. This size worktable provides much greater surface area to support the workpiece and makes sliding the work across the worktable much easier.

To hold the workpiece more firmly in place during mortising, I installed an in-line De-Sta-Co toggle clamp at the front of the worktable. I attached the clamp by tapping mounting holes into

EDITED AND DRAWN BY JIM RICHEY

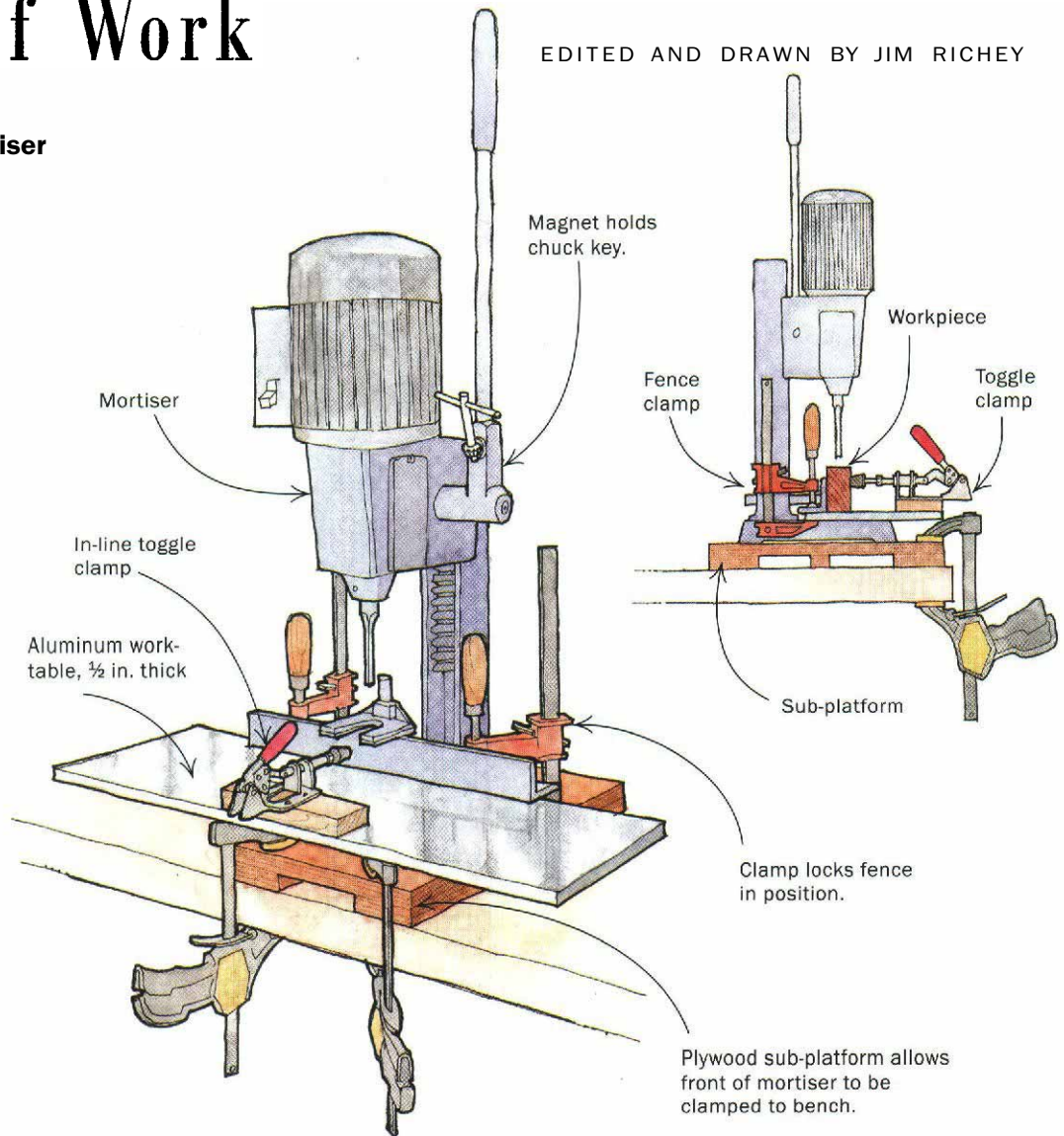

the aluminum plate. The De-Sta-Co clamp applies tremendous pressure against the fence. Often, I found that the pressure of the clamp against the workpiece would cause the fence to slide back regardless of how tight the handle was tightened. So now when my setup is perfect I lock down the fence with quick-action bar clamps.

I made a couple of other adjustments to make the machine easier to use. I replaced all of the original adjustment setscrews with long socket-head screws that are easier to access and adjust. I also placed two rare-earth disc magnets on the machine in handy spots to hold the hex key and the chuck key near where they are needed.

—David Nastri, Wolcott, Conn.

Continued on p. 16



A reward for the best tip

David Nastri won an engraved Lie-Nielsen handplane for his winning tip on retrofitting a benchtop mortise machine to make it more user-friendly and efficient. Nastri turned to woodworking as a form of rehabilitation after suffering some serious head injuries in an automobile accident. He often makes and donates furniture for charitable auctions. Send us your best tip, along with any photos or sketches (we'll redraw them), to *Methods of Work*, Fine Woodworking, P.O. Box 5506, Newtown, CT 06470-5506.

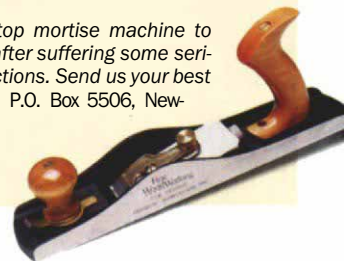

Methods of Work (continued)

Marking table legs

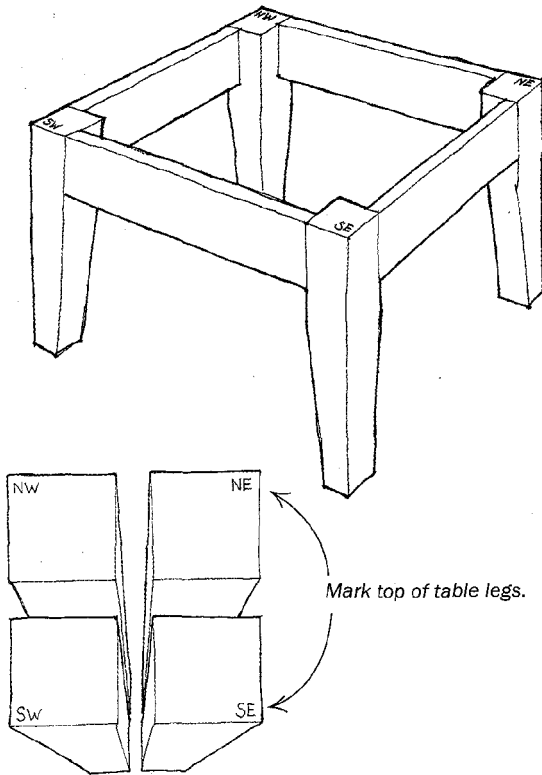

I use a simple compass-based marking method to orient table legs. The system shows the position of each leg relative to the other, as well as the outside corner of each leg. It helps me keep the pieces oriented correctly and avoid cutting a mortise in the wrong side.

—Kirby Snively, Harbor Springs, Mich.

Deep socket fits router collet

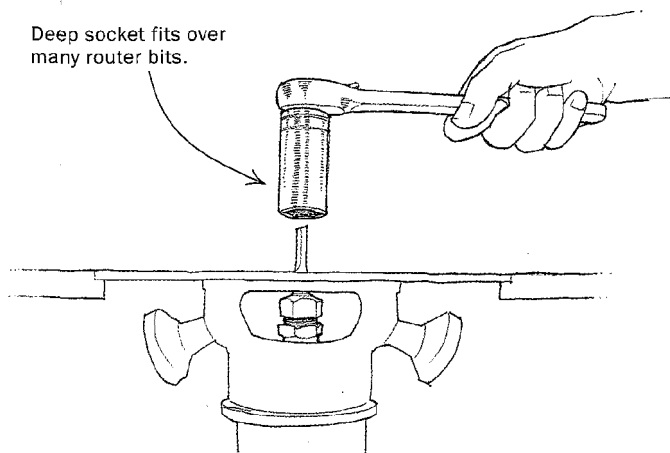

Until I made this discovery, every time I needed to change bits in my table-mounted router I had to lift it out of the table to get at the collet nut. Over the duration of a project, the time spent removing and replacing the router adds up. But I just discovered that a deep

socket (in my case a 7/8-in. spark-plug socket) will fit my router's collet nut and has plenty of room to fit over many of my router bits. Use of the socket greatly reduces the effort required to change a bit. This method should work with any router that has a shaft lock feature, although the size of the socket may vary.

Make sure your router is unplugged before you try this, because a socket-driver handle spinning at 20,000 rpm could really put a crimp in your workday. —Robert F. Reynolds, Columbia, Md.

Trimming solid-wood edging on plywood

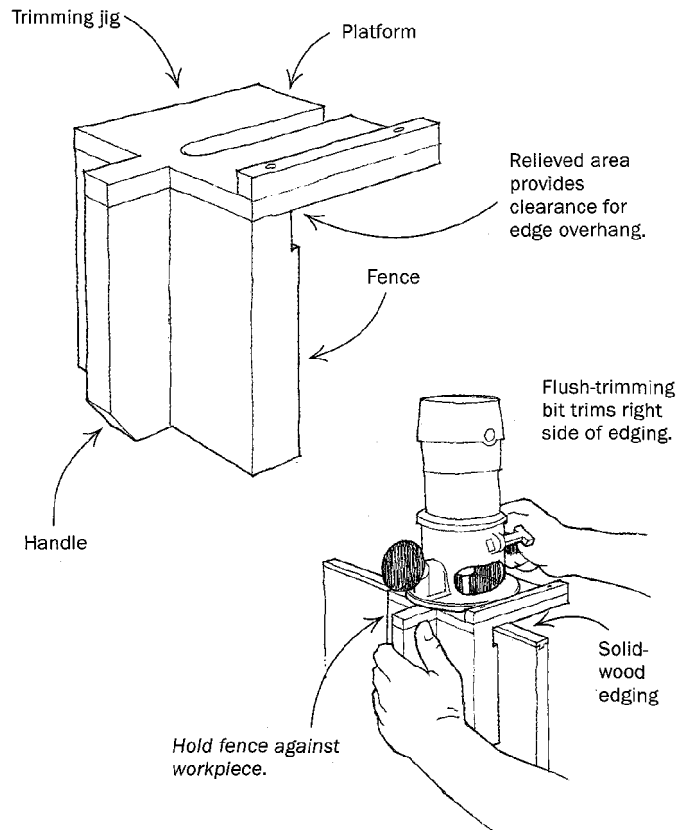

I prefer to cover the raw edges of plywood cabinets with hardwood strips that I join to the cabinet pieces with tongues and grooves. I cut the strips a little wider than the thickness of the plywood to ensure complete coverage. This, of course, requires that the overhang be removed after gluing. I first tried a belt sander to trim the excess, but the sander was always just one little slip away from sanding right through the veneer.

After such a slip, I decided that a trim router with a flush-trimming bit would do a better job. But the narrow edge of the plywood did not provide an adequate support base for the router. So I built the trimming jig shown above, which consists of a handle, a platform and a fence that rides against the plywood. Cut a slot in the top of the platform for the router bit, and attach a stop to the back of the platform to keep the bit centered in the slot. Relieve the fence at the top of the inside surface so that it will clear the overhanging edge and any squeezed-out glue.

To use the trimming jig, clamp the plywood in a vertical position and, with your left hand, bring up the jig's fence to the left side of

Methods of Work (continued)

the plywood. Insert the router so that the flush-trimming bit is riding along the right side of the plywood. Push the jig away from you while exerting a little pressure on the router to keep the bit bearing against the plywood. This will trim the edging neatly without marring either the plywood or the hardwood edge.

—Paul Heiser, Reno, Nev.

Multiple cutoff stops for standard lengths

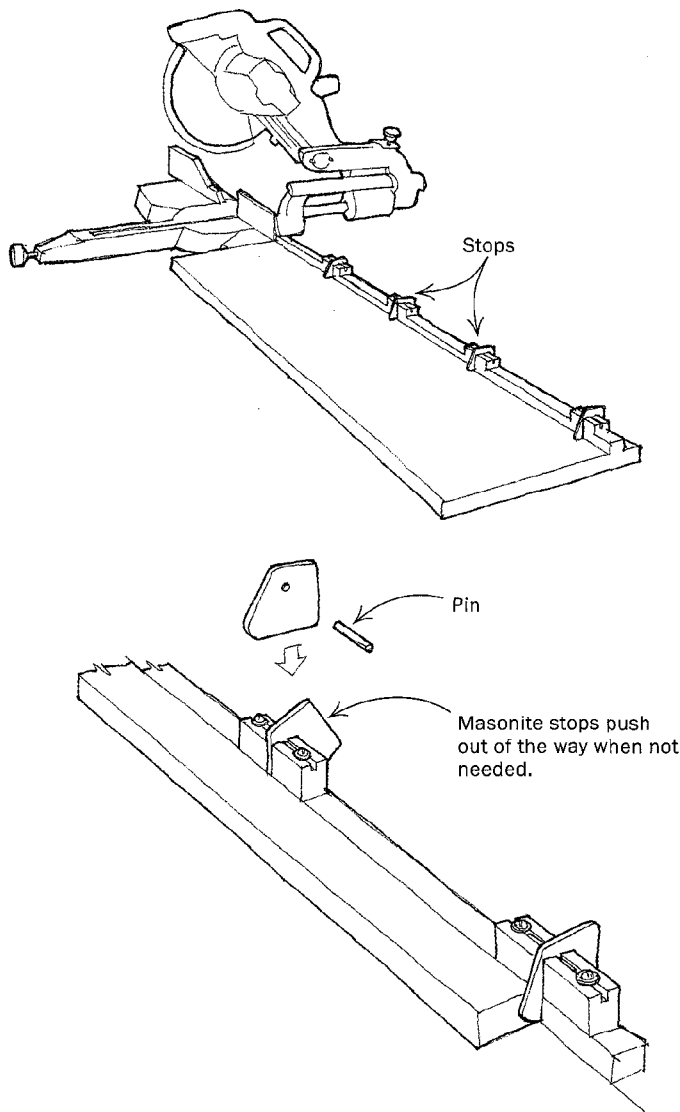

I developed the system of cutoff stops shown above to address a problem in a molding shop. After we removed knots and defects from a piece of molding, we needed to trim the remaining piece, which could be any random length in feet. This system eliminated the necessity of lining up one end of the molding against a mark and allowed the operator simply to butt the stock against any of a series of stops, pushing the rest out of the way as the molding was pressed against the fence. This same idea could be incorporated into a production setup, where any one of several standard lengths

needs to be cut quickly. The beauty of the system is that there is nothing to move or adjust. A positive stop exists at each position. Any one particular stop can be used without adjustment and without deactivating any other stop.

The basic operation is as follows: Suppose the 7-ft stop is needed. Simply place the end of the stock against the 7-ft. stop, then push the stock back against the fence. The other stops between the blade and the 7-ft. stop, extended only by their counterbalanced shape, fold effortlessly out of the way.

The stops are made from 1/8-in.-thick Masonite paneling. To make them, I stack a dozen or so rough blanks together, drill the hole for the pin, then bolt the stack together. I shape them all at once on a belt sander. I keep extras, and if one gets broken, worn or damaged, it's a simple matter to replace it

—Roger Alan Skipper, Oakland, Md.

Segmented turning blanks on a disc sander

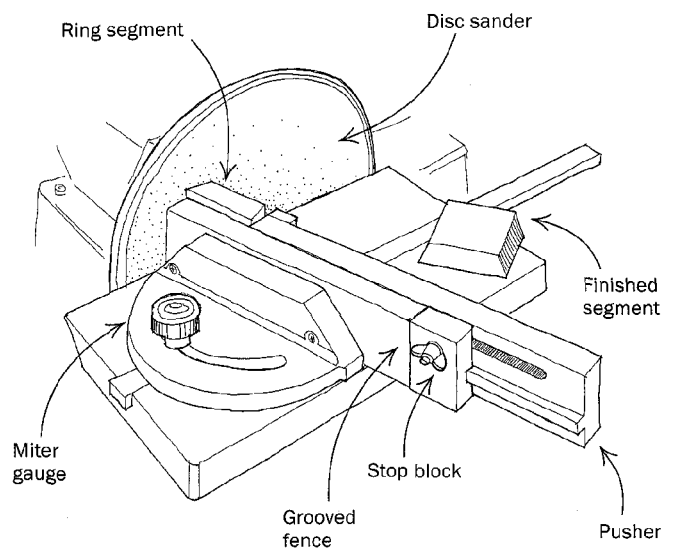

I like to turn bowls from ring assemblies that have been laminated from segmented blanks. The problem with building ring assemblies is that any minor discrepancy in the bevel angle or the size of each segment will accumulate into a large gap when you glue them all together. To avoid that problem, I devised this jig, which ensures that each segment is exactly the same.

You can make the jig from any close-grained hardwood. It consists of three simple parts: a grooved fence that attaches to the miter gauge; a pusher that slides along the fence; and a stop block.

To use the jig, first miter the segments on a tablesaw to a rough size and angle. Allow about 1/16 in. extra in length. Scribble pencil marks on the miters of all of the segments and then—with the miter gauge set at the correct bevel angle—sand one end of all of the segments on the disc sander until the pencil marks disappear. Find the shortest segment and sand the remaining end miter of this segment to produce a master. Use the master to set the stop block on the jig and tighten the wing nut to lock it into place. One by one, place the remaining segments against the fence and sand the

Methods of Work (continued)

other ends, sliding the segment into the sander until the pusher hits the stop block. All segments should now be the same length and be beveled at the same angle.

—Bob Deacon, *Gorleston-on-sea, Norfolk, England*

Quick tip: I use a food vacuum-storage setup for small veneering jobs. Because the bags are sealed, the vacuum pump doesn't have to run continuously, and you can do as many projects as you want with only one vacuum tool. With the proper attachment, the device will draw air from Mason jars to enable long-term storage of finishes with no skin forming on the top.—Tom Love, *Delmont, N.J.*

Miter-gauge hold-down

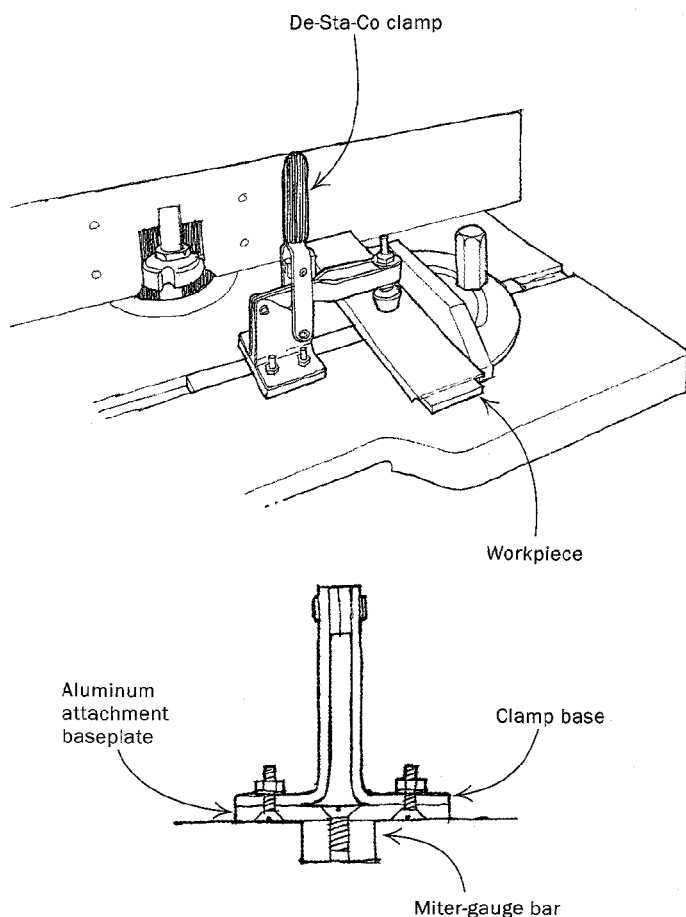

I was having trouble shaping the ends of cope-and-stick rails on my shaper. The narrow pieces were difficult to hold tightly to the miter gauge, and they often shifted position during the cut. So I came up with the clamping miter gauge shown above. It is inexpensive, easy to make and works beautifully. The same idea could be easily adapted to a router table or a tablesaw.

I used a De-Sta-Co No. 210 clamp (available from many mail-order suppliers). Attach the clamp to your miter-gauge bar by first screwing a 1/4-in.-thick aluminum baseplate (about 2 in. by 3 in.) to the bar. You will need to drill and tap the bar to attach the baseplate. Drill holes through the baseplate to match the holes in the

base of the De-Sta-Co clamp and attach the clamp with machine screws.

—Bjarn Sorensen, *Tempe, Ariz.*

Quick-locking featherboard

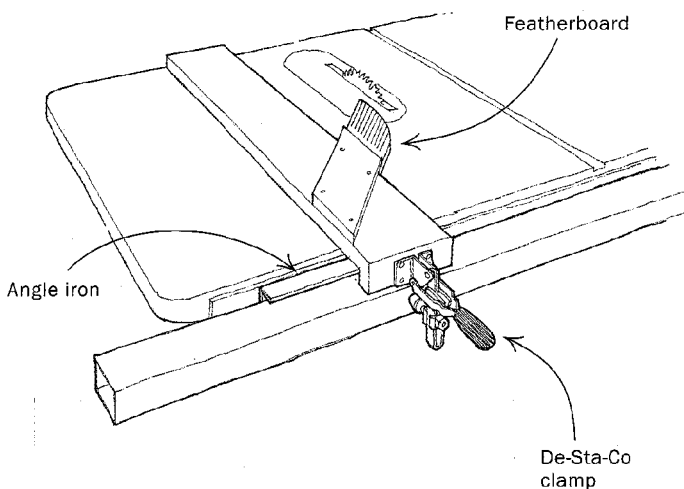

I was unable to find a featherboard that I could adjust as quickly and lock in place as solidly as my Biesemeyer fence. I finally took inspiration from the locking mechanism on my fence and made the featherboard shown above with a toggle clamp, a length of angle iron and some scrap pieces of wood.

—Mike Miller, *Milwaukee, Wis.*

Stepped crosscut box

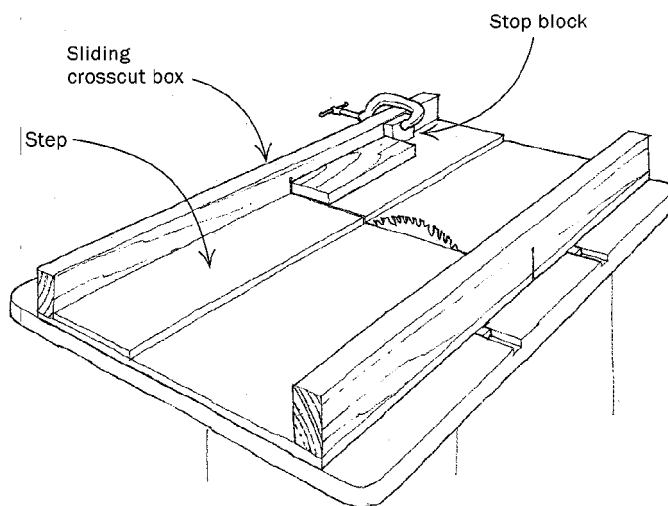

I added a removable step to the sliding crosscut sled for my table-saw, as shown above. This gives me two fences to work with. I use the front fence to square one end of my stock and the back fence to cut the stock to length using a stop. Another advantage of this setup is that I can replace the step at any time and saw a fresh kerf so that I can better see the exact cut line. Also, I can remove the step to cut wider pieces.

—Anthony Leighton, *Navarro, Calif.*

Methods of Work

EDITED AND DRAWN BY JIM RICHEY

A tablesaw splitter you will actually use

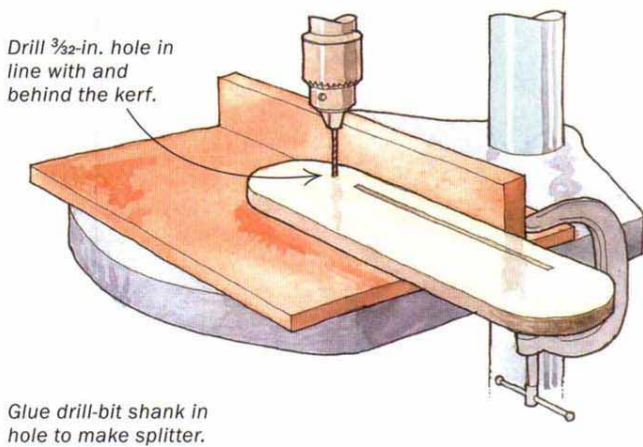
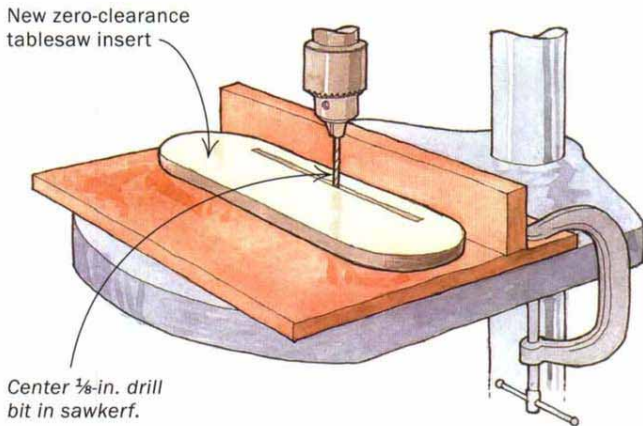

Adding a splitter to a new tablesaw throat insert is an excellent safety practice. Once installed, neglecting it requires a conscious effort, so the odds are that it will see everyday, real-life use.

I've found, though, that the usually recommended procedure of extending the kerf behind the blade and gluing in a wooden

tongue is hard to pull off without introducing minuscule errors. And the slightest error will result in a device that snags the workpiece. This method solves those problems.

Raise the sawblade through the new insert. Then place the insert against a fence on a drill-press table. Align things by lowering a drill bit of a diameter that is equal to the blade thickness (usually 1/8 in.) into the kerf. When the bit is centered in the kerf, lock the fence, change to a drill bit 1/2 in. smaller, switch on the drill press and bore a hole near the outfeed end of the kerf. Now push that same drill bit into the hole, shank up, along with a dab of cyanoacrylate glue. The drill bit will now serve as the splitter pin. It will be aligned perfectly with the sawkerf and should have about 1/4 in. of clearance on each side. —*Michael Standish, Roxbury, Mass.*

Wedge shims for edge-gluing

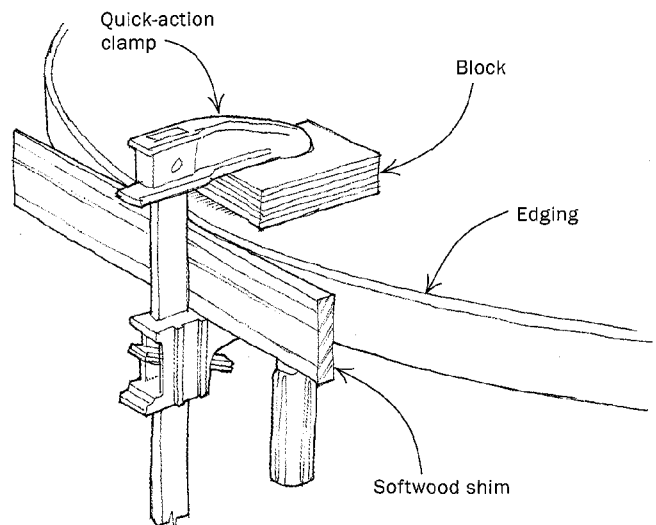

Glue-ups are among the most frustrating procedures in woodworking. When you expect it to be a bear, it's a lamb, and when you expect it to be Little Bo Peep, it turns out to be a grizzly bear. This tip was born out of desperation during what was perceived to be a Little Bo Peep procedure—gluing a wood edging strip to a curved top.

I know there are several kinds of dedicated clamps designed for gluing edges. In my opinion these clamps are too pricey, take up too much precious real estate when they're not being used, and they're too limited in the thickness they can accommodate. Not so with this simple technique (above), which requires only the quick-action clamps you probably already own and a package of door-installation shims.

Simply tighten your quick-action clamp close to the edge of the

A reward for the best tip

Michael Standish won an engraved Lie-Nielsen handplane for his winning tip about making a splitter for the throat plate on a tablesaw. His design is one of those ideas that reveal an elegance grounded in simplicity, and it makes a tablesaw safer to use. Standish earns a living as a finish carpenter, architectural millworker and occasional furniture maker. Send us your best tip, along with any photos or sketches (we'll redraw them) to *Methods of Work*, Fine Woodworking, P.O. Box 5506, Newtown, CT 06470-5506.



Methods of Work (continued)

top to be glued, accounting for the thickness of your edging and the shim. Apply some decent pressure to the clamp. Add some sandpaper blocks and really cinch down the clamps if you need a lot of pressure. Apply glue and set the edging in place. Then smack a softwood shim between the edging and the bar of the clamp to hold the edging tightly in place until the glue sets.

—David Guarino, South Plainfield, N.J.

Handplane chamfer guide

Clamp the guides to body of plane, near the front.

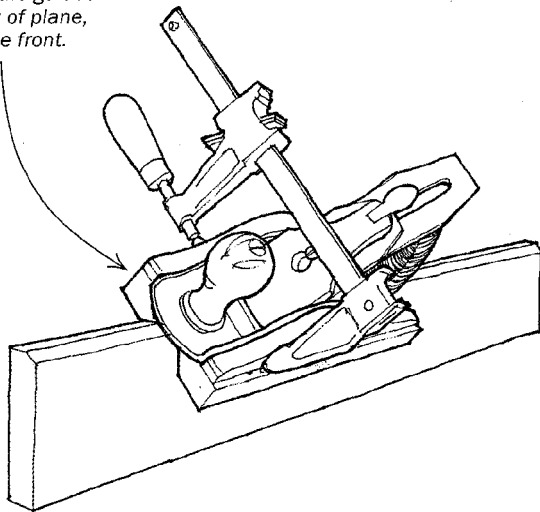

Side block fits profile of plane.

Chamfer guide

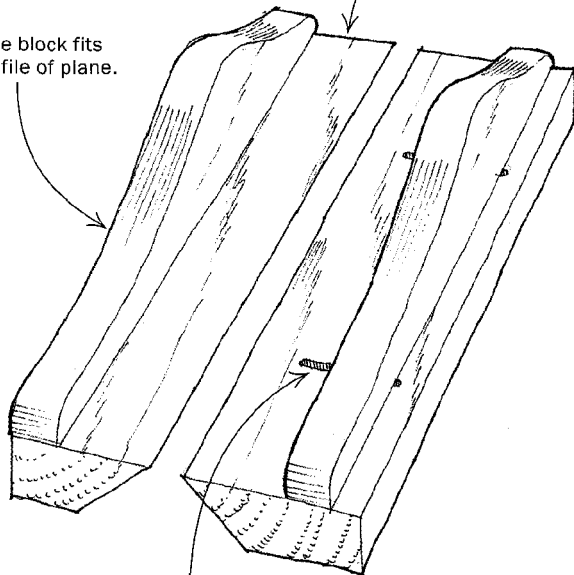

Slots allow adjustment.

few basic hand tools. The design called for chamfered edges. On a test run I marked the top and sides of the stock and planed down to the pencil lines. The results weren't too bad, but they just weren't consistent enough for the longer boards I needed.

To solve that problem, I built a chamfer guide to attach to the sole of my jack plane (see the drawings at left). I first planed the edge of a length of scrap to 45° and then cut it in half lengthwise, to make two pieces for the base. To the tops of those I added a couple of side blocks screwed on tightly to fit against the body of the plane. I cut slotted mounting holes in one of the base pieces to allow for adjustments.

I clamped the guides to the sides of the plane—ahead of the mouth where there is a support rib—so that I wouldn't crack the casting. Loosening the screws on the adjustable guide and sliding it one way or the other controls the width of the chamfer. Once I had the size of the chamfer set, the planing went very smoothly.

—Darrell LaRue, Oakville, Ont. Canada

Taming unruly power cords

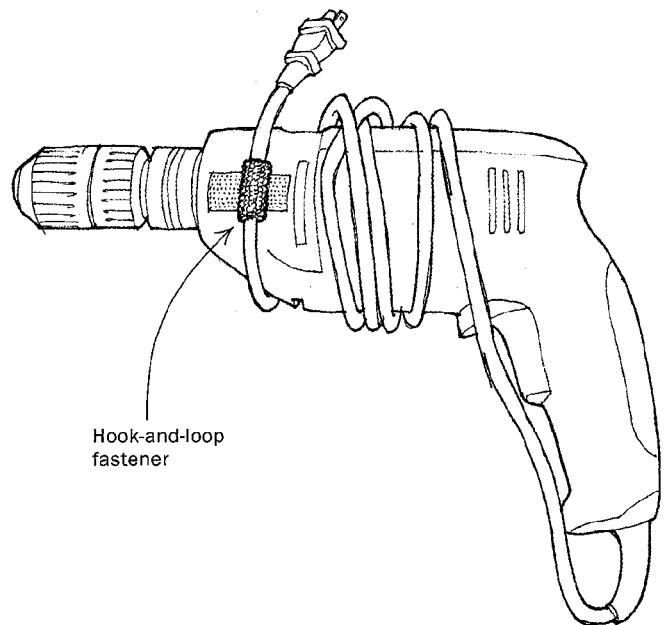

Hook-and-loop fastener

Most portable power tools, such as drills, saws and routers, have no provisions for holding the power cord in place. Try this.

Wrap a strip of hook-and-loop fastener (like Velcro), with a self-adhesive backing, around the cord about 2 in. or 3 in. from the plug end. Then wrap the cord around the tool to determine where the strip will come in contact with the tool body and adhere the mating half of the strip at that location. Now you can wrap the cord around the tool and press the hook-and-loop strips together to fasten the cord. No knots, loops or unraveling cords get in the way when you need to store or transport the tool.

—Leonard Feldberg, Chestnut Ridge, N.Y.

I took on a project at my summer cottage to make 90 ft. of window trim. My options were limited because I was able to bring only a

Quick tip: To make a pattern for duplicating a complex turning, first turn a prototype. Then cut a piece of 1/16-in.-thick Plexiglas to

Methods of Work (continued)

roughly the same shape. With the lathe set at a high speed, press the plastic into the turning spindle. The plastic will melt into an exact, reverse pattern of the spindle shape.

—Bernie McMellon, Taft, Tenn.

An easy way to chop square mortises

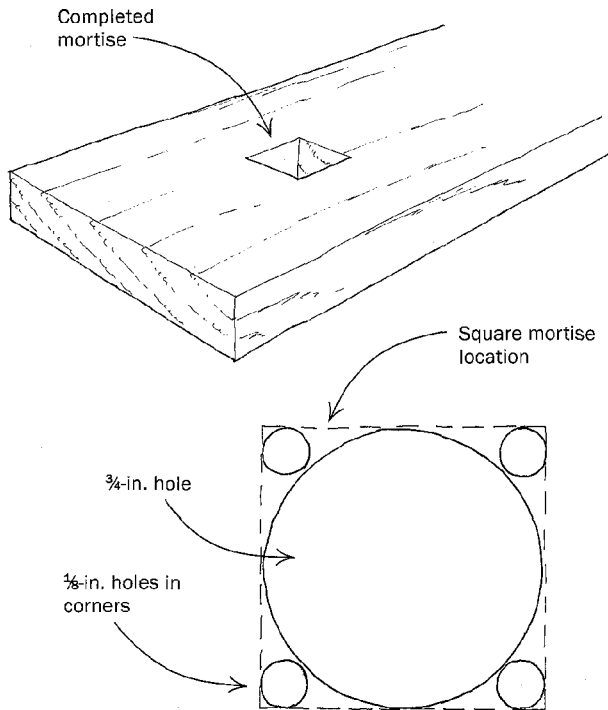

When I had to chop several 3/4-in. square holes in a workbench top, I first tried removing the center of the hole with a 3/4-in. bit. Then I had the idea to remove even more waste by drilling 1/8-in. holes in each of the corners left by the 3/4-in. bit. The holes in each corner remove a significant additional amount of waste and made cleaning them out by hand easier and quicker.

—John Adam Jones, Norman, Okla.

Making curved moldings with a router

With this router template and guide fixture (see the drawings at right), you can easily make fancy curved moldings, such as oval picture frames and gooseneck moldings for grandfather clocks. The critical elements of this fixture are an extended 3/8-in.-thick Lexan baseplate and a number of 1/8-in.-thick Masonite guide discs in various diameters.

The discs can be attached to the baseplate in one of several ways. Because I have access to metal machining tools, I made a threaded, lipped brass ring and a matching nut. However, a common 1 1/2-in. PVC slip-joint adapter (also called a trap adapter) makes an inexpensive, though less elegant, substitute. You will need to cut off the end of the PVC adapter to make it fit. Whatever attachment device you come up with, make sure that the largest router bit you intend to use will pass through the inside diameter.

To make the guide discs, first make a special faceplate for your

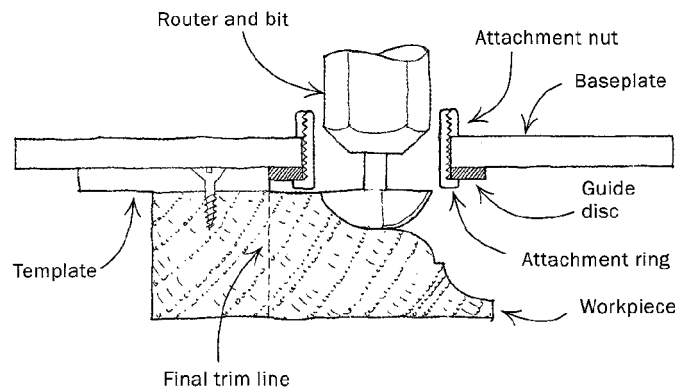
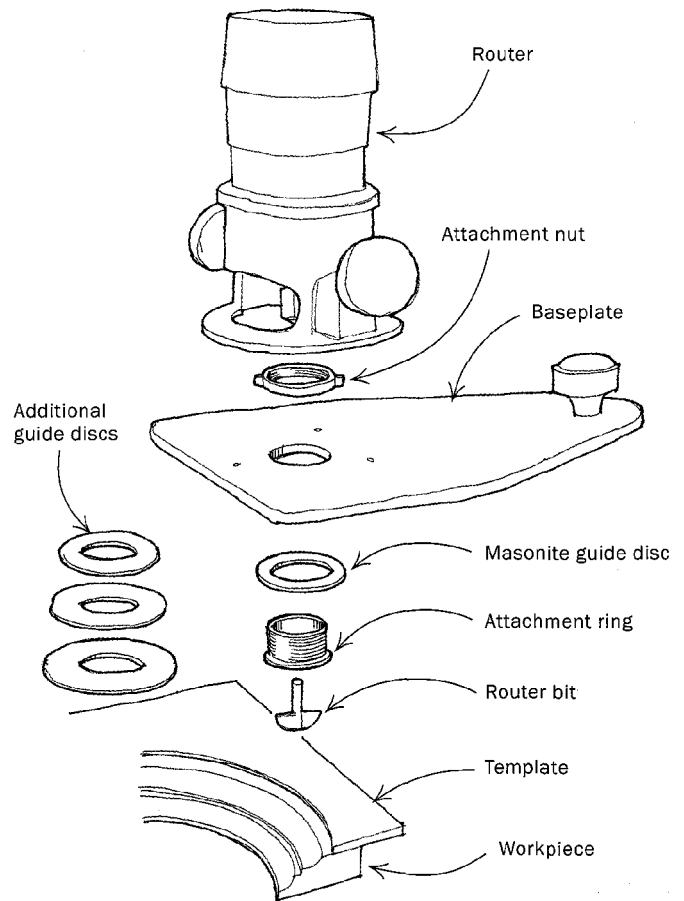

lathe with a stub to fit the inside diameter of the disc. Drill out a 1/8-in.-thick Masonite blank to fit the stub, attach the blank to the faceplate and turn the disc to the desired diameter. If you know the exact sizes you need, you can make up only those sizes. I use the guide for many molding profiles, so I made a large number of discs in 1/8-in. graduations, ranging from 1 3/4 in. to 4 3/4 in.

Before you can use the fixture, you need to cut out a curved template the shape of the molding you want to make. I use 1/4-in.-thick material for the template. An outside or an inside template will

Methods of Work (continued)

work equally well. Because you want to have the template nearest the thickest edge of the molding, this will dictate whether the template should be an outside or an inside form. I usually make the template the same size as the final trim line of the molding.

Screw the template to the workpiece. (Clamps can get in the way.) Now place the extended part of the router baseplate on the template, with a guide disc riding against the edge of the template, and begin routing the first profile—the one that is outermost from the template. Deep cuts must be done in several passes. When necessary, I modify corner-rounding bits and other pattern bits by carefully grinding off the ball-bearing stem.

After the first profile is done, change the bit and install a new guide disc to step the bit in on the workpiece. Rout the second profile. Continue this process in several steps until the desired molding profile is complete. —*Leslie Zielicke, Fond du Lac, Wis.*

Cure for puny knobs

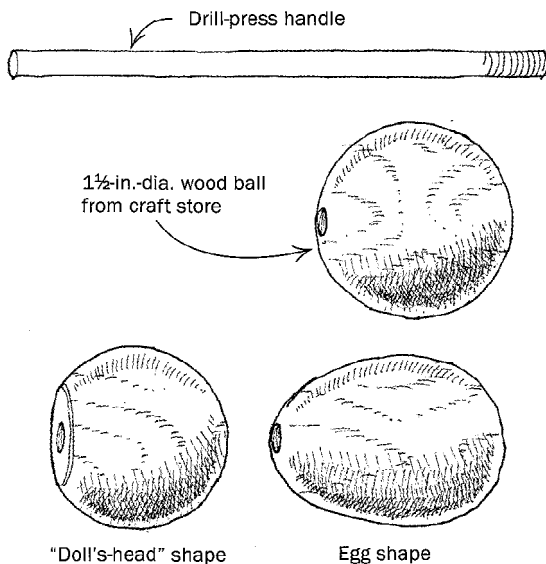

If you find the puny knobs on your benchtop drill press (or any other tool) difficult to grasp, here's an easy solution. Buy some 1 1/2-in.-dia. hardwood balls from a craft store, drill a hole in the balls the same size as the handle shafts and force-thread them on to the shafts. Secure the balls with some epoxy. Wipe on a couple of coats of finish, and you're set.

For variation, craft stores also carry egg-shaped and "doll's-head" wooden balls. A complete set should cost you less than \$2.

—*R.B. Himes, Vienna, Ohio*

Dedicated marking gauge for duplicate spindles

If you have to turn a large number of identical spindles, this simple marking gauge (above right) will save you time and increase your accuracy. Make the gauge from a 1/4-in.-thick scrap of straight stock about 1 1/2 in. wide. Cut a lip on one end and drive small finish nails into the edge at key marking points for the spindle. Snip the nails to about 1/8 in. long and sharpen them with a file. Make sure all nails will touch the workpiece. Add a label and drill a hole

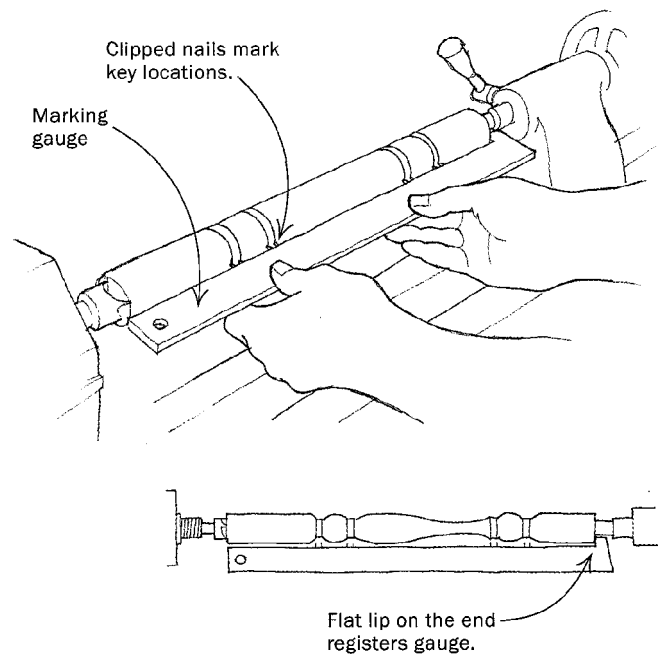

to hang the gauge on the wall for future use. To use the gauge, first turn the spindle blank to a cylinder and square off the tailstock end. Place the lip of the gauge flush with the tailstock end and push the gauge into the turning stock so that the nails mark the spindle locations. Deepen each mark with the point of a skew so you won't lose them. Now you can turn your duplicate spindles with both confidence and consistency.

—*Richard Dieterle, Millersville, Pa.*

Aid for chopping dovetail pins

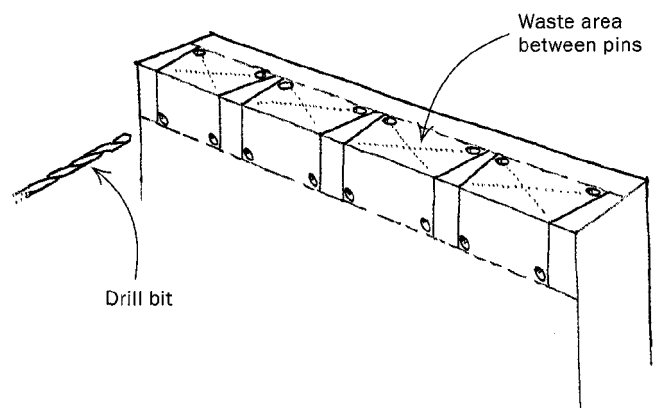

When I make half-blind dovetails in drawer fronts, I use the following technique to chop out the waste between the pins. I chuck a small bit in an eggbeater-type hand drill and then drill four holes in each tail recess, as shown above. I sight the angles by eye. The holes allow me to chop out the waste material more quickly and neatly, particularly when I'm working with hardwood.

—*Bruce Cowen, Kalamunda, Western Australia*

Methods of Work

EDITED AND DRAWN BY JIM RICHEY

Magnetic drill-press fence

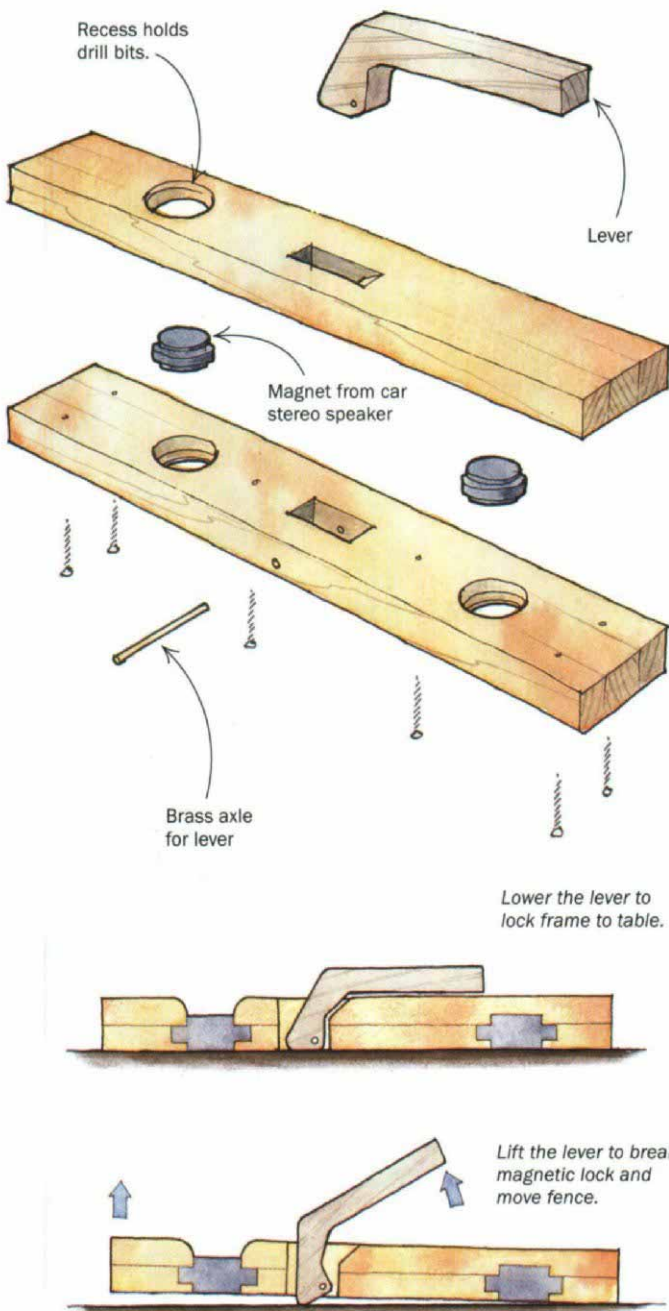

This magnetic drill-press fence is easy to build, simple to adjust and locks down tight. As an added bonus it has a handy magnetic cup for holding loose drill bits.

In the first version I made, the strong pull of the magnets made it difficult to fine-tune the fence's location on the drill-press table. To solve this problem, I installed a handle with a lever that raises the fence enough to break the magnetic pull. This improvement made it easier to adjust the fence. Once the fence is located where I want it, I lower the handle, and the strong magnetic pull takes over, securing the jig to the iron drill-press table. It works great, but you need to take care not to bang your workpiece too hard against the fence, which may cause it to move slightly.

—Lyle Mosher, San Jose, Calif.

Router table borrows table saw's fixtures

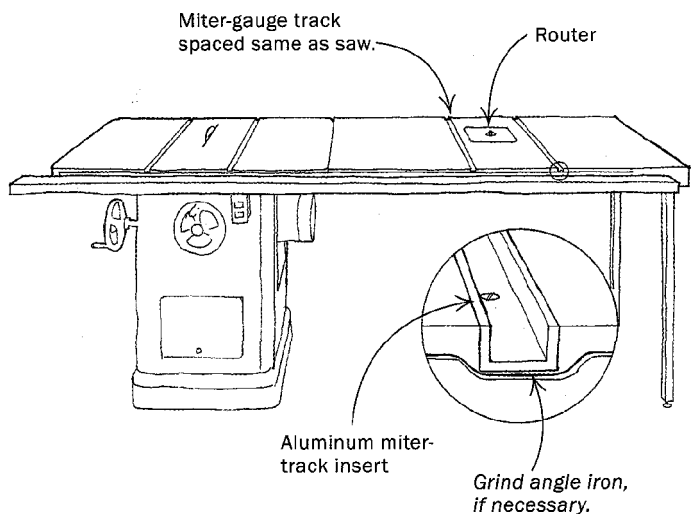

One of the unique advantages of the high-end European combination machines is that you can use the sliding table and the cross-cut fence with both the shaper and the table saw. I decided to do something similar on my table saw by mounting a router in the extension table and installing two miter-gauge slots in the extension table that matched the spacing of those on the saw table. This allows me to use not only the rip fence and the miter gauge but also any sliding fixtures I've made for the saw.

To make this setup, you need to purchase aluminum miter-track inserts (sold by Rockier and other mail-order woodworking suppliers). These inserts are necessary because most extension tables are made from sheet goods that will not hold up to extended wear.

Installation is easy. Simply use your saw's rip fence to guide a router fitted with a straight bit. Rout two parallel dados in the top

A reward for the best tip



Lyle Mosher won an engraved Lie-Nielsen handplane for his winning tip about making a magnetic drill-press fence. For anyone who has tried to find a suitably flat clamping surface on the underside of a drill-press table, this tip comes as a handy solution to a common problem. Mosher has practiced residential architecture in San Jose, Calif., for more than 20 years. His self-taught woodworking pursuits consist of making cabinets and furniture for his own home. Send us your best tip, along with any photos or sketches (we'll redraw them) to *Methods of Work*, Fine Woodworking, P.O. Box 5506, Newtown, CT 06470-5506.

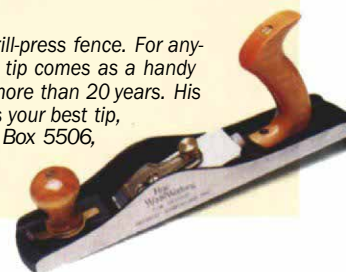

Methods of Work (continued)

of the extension table, matching the spacing of the slots in the saw table. Screw the aluminum miter-track inserts in place, and you are ready to go.

One word of caution: Be sure to grind or file away the lip of the angle iron at the front and back of the extension table, as needed, to provide enough clearance before routing the groove.

—Judd Fancher, Glendale, Ariz.

Quick tip: To quickly add a great nonslip surface to your tablesaw's miter-gauge fence, spray it with a flexible rubber coating. The product I use, Plasti Dip Spray-On Heavy Duty Flexible Rubber Coating (plastidip.com), is available at many home centers and hardware stores.

—Fred H. Walsh III, McDonald, Tenn.

Turning dogleg spindles

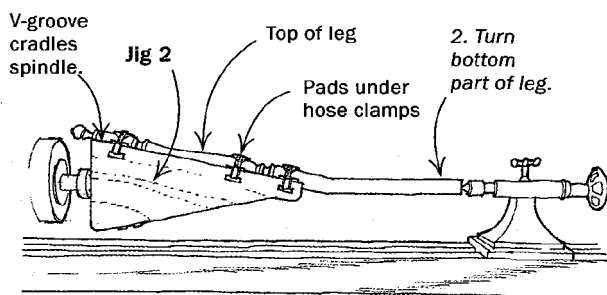
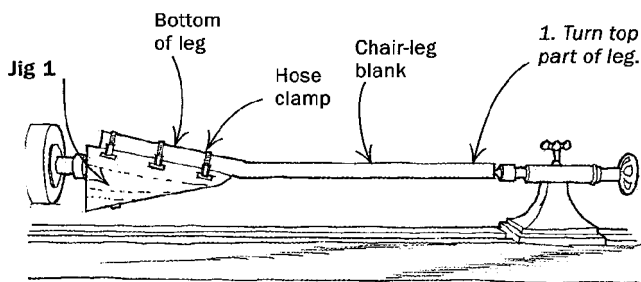
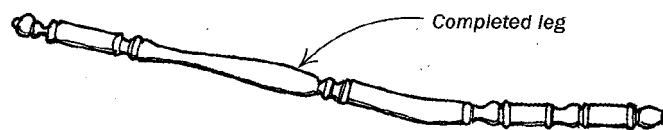

I discovered this technique for turning the angled back legs of chairs in an old wood-turning book. First, prepare the leg blanks on the bandsaw. In most cases I use a 2-in. offset from the seat height to the bottom of the leg. With this setup, you turn the leg in two steps using two jigs.

In the first step, attach the bottom portion of the leg to a jig and turn the top part above the seat. In the second step, reverse the workpiece and place the top of the leg in a second jig and turn the bottom part of the leg below the seat.

Three important principles dictate the design of the two jigs.

First, the assembly of the workpiece plus the jig must be balanced so that the center of gravity is on the turning axis. This eliminates vibration on the lathe while turning. Second, the jig must extend as far as possible down the leg to lend rigidity to the workpiece. Third, the jig must provide a convenient method of attaching the work and, in the case of the second jig, do so without damage to the already-turned portion of the spindle. To accomplish this, I made the edge of the second jig in the form of a V-groove and lined it with leather pads under the hose clamps that attach the spindle to the counterweight.

—Jon Siegel, Andover, N.H.

Gluing laminated curves with screw blocks

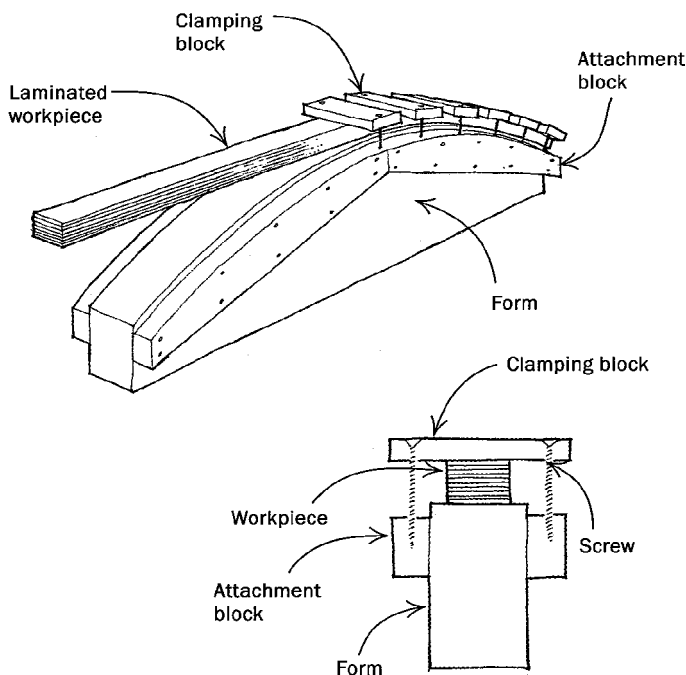

Here is a method for gluing up laminated curved components that eliminates the need for large numbers of expensive clamps. By using simple hardwood clamping blocks and drywall screws, you can get all of the clamping pressure you need.

First, you'll need to make a curved form for the laminated workpiece. The form should be just a bit wider than the workpiece. Then make screw-attachment blocks for both sides of the form, using construction-grade 2x lumber cut roughly to the shape of the curve. Screw the attachment blocks to the outsides of the form, recessing the curved edges slightly, as shown above.

Next, cut a few dozen 3/4-in.-thick hardwood clamping blocks long enough to span the full width of the form, including the attachment blocks. Drill pilot holes for screws about 1 in. from each end of the clamping blocks.

After a dry run, spread glue on each of the lamination plies and stack them together on the form. Place an extra (unglued) ply on top to help spread the clamping pressure and to prevent marring the workpiece. Starting at the center of the form, screw the clamping blocks in place, perpendicular to the curved plies. Space the blocks about every 2 in., more or less, depending on the radius of

Methods of Work (continued)

the curve. You can adapt this same basic concept to laminate inside curves or to add edge-banding to irregular contours.

—David Gilmore, Maple Ridge, B. C., Canada

Dust collector for the tablesaw

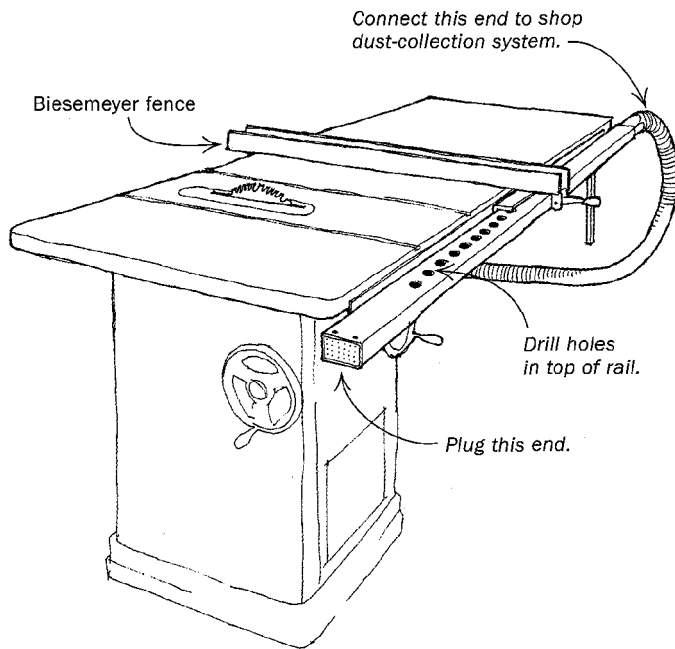

Here's a simple modification to a Biesemeyer tablesaw fence that will dramatically reduce the amount of sawdust that sprays off the front of the saw. Drill 10 or so $\frac{7}{8}$ -in.-dia. holes, 1 $\frac{1}{4}$ in. apart, in the top of the Biesemeyer fence's square steel rail in the area in front of the blade. Seal off the left end of the rail with a wood plug, and attach a vacuum hose from your dust-collection system to the right end of the rail. The modifications will not affect the operation of the fence, and the holes in the fence catch much of the dust that spins off the blade.

—Timothy Dalton, Middleton, Wis.

Quick tip: Bamboo skewers make great plugs for filling worn or torn-out screw holes. Put a dab of glue on the blunt end of a skewer, push it into the hole and snap it off. Skewers are available in most supermarkets.

—James McGarry, Wittina, Australia

Wedged dovetail joint

I first made these wedged dovetails (see the top drawing at right) for a practical reason—to counteract the tendency of wide, dovetailed carcasses to open at the corners in my dry climate. I discovered that the resulting joint is not only stronger but also visually interesting because you get significant dovetail shapes on both sides of the joint.

To make the joint, cut the tails first. Instead of marking the tails square on the side of the board, mark the same angle on both the top and the side. Cut the tails and remove the waste. Then mark the pins from the tails and cut the pins as usual. When you put together the joint, the inside will fit exactly, but on the outside you will get wedge-shaped gaps into which you glue and knock in

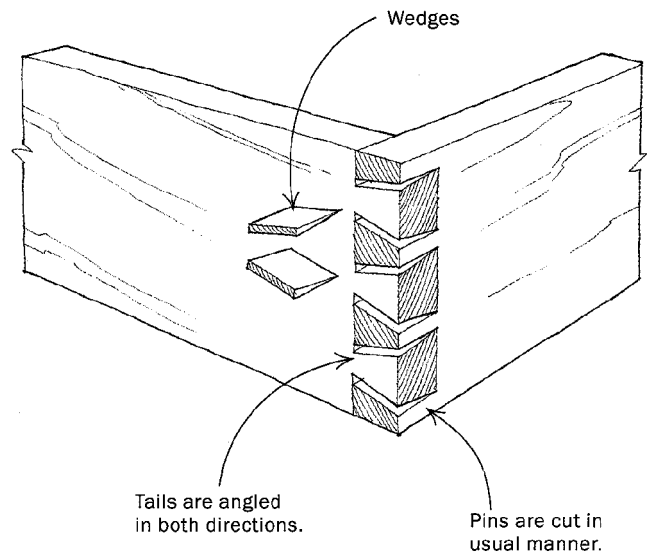

small wedges. These wedges are easily prepared with a simple jig on the tablesaw. When you knock in the wedges, the whole thing is drawn together tightly. This connection is forgiving of errors, inseparable in both directions and also quite handsome.

—Zwi Rotem, Kiriat-Tivon, Israel

Holding work for hand-jointing

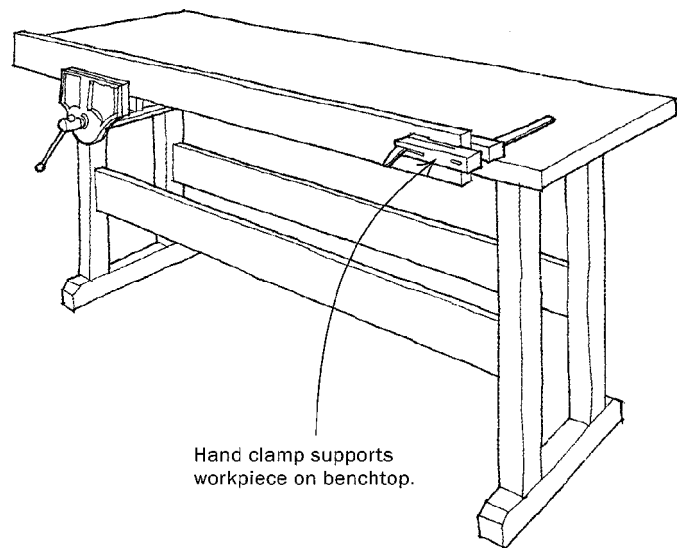

If you don't have a workbench especially designed for the job, holding a long piece of wood for edge-planing is a hassle. Here's a method that is fast and simple. Clamp one end of the board in the vise and attach a hand clamp to the other end, as shown above. The clamp rests on the benchtop and prevents the board from slipping down. I use cam clamps because they require only one hand to position and tighten them in place, but any hand clamp will work.

—Bev Hardy, Poughkeepsie, N.Y.

Methods of Work

EDITED AND DRAWN BY JIM RICHEY

Small-shop solution for cutting sheet goods

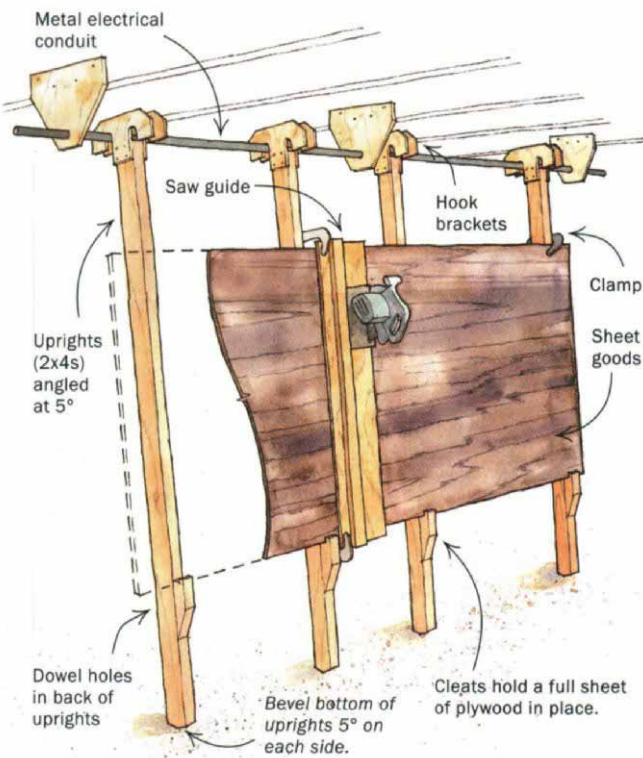

I work with sheet goods frequently and finally came to realize I needed a panel saw to make that work easier. There simply was not room for such a tool in my small basement shop, so I designed a fixture that makes cutting sheet goods quite simple and efficient. An added benefit is that I've since discovered other uses for the fixture as well.

I needed something that would be lightweight, easy to set up and easy to store. It couldn't be freestanding or mounted to the wall because I didn't have the room. So I came up with a design of four 2x4 uprights that hang from the ceiling.

To make it, I mounted a 10-ft. piece of $\frac{3}{4}$ -in.-dia. metal electrical conduit spaced 4 in. from the ceiling, using plywood brackets. After some experimentation, I decided that the uprights should lean at an angle of 5°, so I cut the bottoms at this angle from both sides to make a foot beveled toward the center. By tilting slightly, the uprights can better support a full sheet of plywood without the sheet tipping over. Then I cut the uprights to length and mounted two plywood hook brackets to the top of each upright that slip over the conduit. Note that the hook brackets are two-sided and

allow tile uprights to be reversed. Finally I added a 2x2 cleat with a plywood lip about 24 in. up from the bottom of each upright. These cleats easily support the weight of a full sheet of plywood.

To use the fixture, I slip the hook bracket of each upright over the conduit and then rest the lower end on the floor. When crosscutting I space the uprights so that two are near the ends of the panel and two straddle the saw-cut location. I lift the plywood onto the cleats and clamp it to the uprights. Then I mark the sheet and clamp my saw guide on the cut line. I use a simple saw guide made from a strip of $\frac{1}{4}$ -in.-thick plywood with a $\frac{3}{4}$ -in. runner fastened to it. The first cut trims the guide to the right width, so that from then on it is easy to align it with a cut line marked on a workpiece.

I can also use the fixture to rip panels. To do so I clamp the top of the panel securely to the uprights and set the sawblade to barely cut through the sheet goods.

Now for some extra benefits. By reversing the uprights, drilling $\frac{3}{4}$ -in.-dia. holes every 10 in. and filling the holes with 12-in.-long dowels, I get a great drying rack. And by adding a shower curtain suspended from the conduit with curtain rings and a piece of plastic to protect the floor, I can spray or stain right on the fixture.

—Richard W. Beebe II, Hamden, Conn.

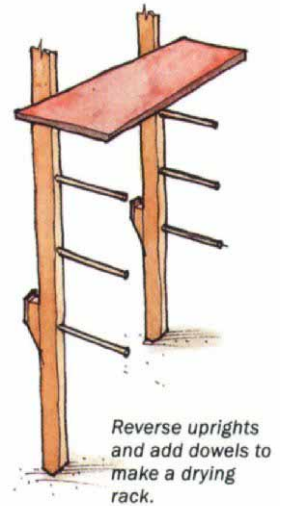

Custom tool hooks from PVC pipe

1. Cut section of Schedule-40 PVC pipe.

2. Remove one-quarter of circumference with bandsaw.

3. Heat and straighten back.

4. Cut slot to fit specific tool.

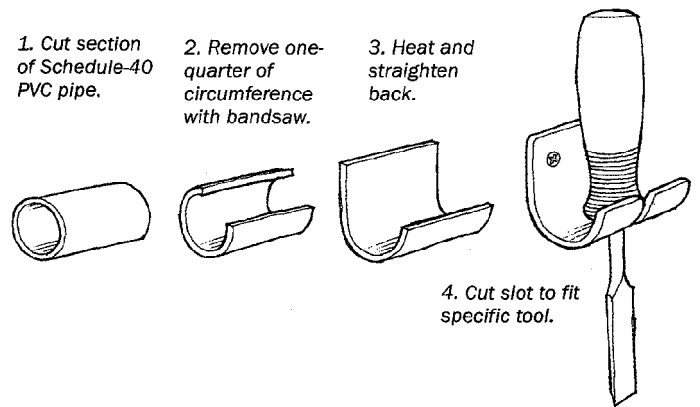

These tool hooks, made with PVC plumbing pipe and a few simple tools, are strong, nonmarring, inexpensive, quick to make and

A reward for the best tip

Richard Beebe makes a living in the digital world managing the data network for the Yale School of Medicine. His woodworking pursuits, accomplished in a small basement shop, consist mainly of furnishings and cabinetwork for his home. Tight space constraints inspired him to design a dual-purpose vertical rack for cutting sheet goods on one side and to serve as a drying rack on the other. Send us your best tip, along with any photos or sketches (we'll redraw them) to Methods of Work, Fine Woodworking, P.O. Box 5506, Newtown, CT 06470-5506.

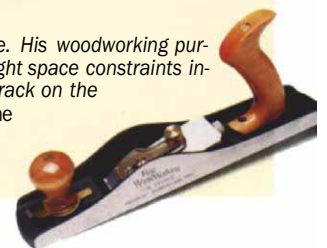
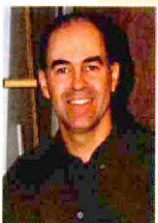

Methods of Work (continued)

custom-fitted to each specific tool. Start by cutting off a length of Schedule-40 PVC pipe to fit your application. A 3-in. length of 1½-in.-dia. pipe is a good size for a screwdriver or chisel, but you can vary the pipe size and length for each application. Using a bandsaw with a ¼-in. blade, cut out one-quarter of the circumference, as shown in the sketch on p. 16, to make a C profile when viewed from the end. The pipe tends to close around the blade as you cut, so a smaller blade works better.

Next, use a heat gun to warm up about a quarter of the circumference of the pipe until it is soft and pliable. It takes only a minute, so don't overdo it. Lay the softened part of the plastic on a flat surface and place a heavy, flat object on the pipe—or clamp it lightly in your vise—until it cools, which takes a few minutes. The altered pipe will have a J profile.

To finish the hook, customize it in whatever way needed, cutting a slot in the bottom to hold the tool you want to hang. Drill a couple of holes for screws, and mount the hook on the wall.

—John J. Black, Clinton Township, Mich.

Speed square mitering sled

For cutting 45° miters on my tablesaw, I use a crosscut sled equipped with a common plastic speed square. To build the sled, attach a runner to the underside of a scrap piece of plywood. Turn the plywood sled 180° in the miter track and cut off the waste along that edge, making it perfectly parallel to the blade. Turn the sled back around, then attach the top and bottom fences 90°

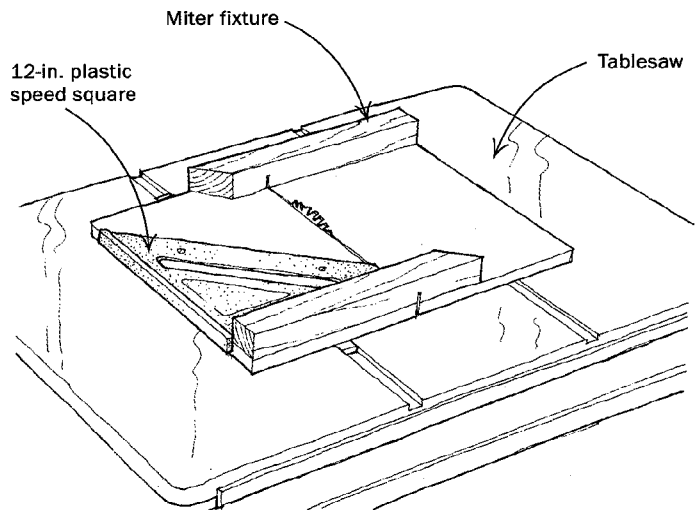

square to that trimmed edge. Stagger the fences on both sides of the sawblade to make more room on the sled to handle long workpieces that need to be mitered

Now place the flange of a plastic 12-in. speed square against the trimmed edge of the sled and rest it against the bottom fence. Attach the square to the sled at this location with three or four small

Methods of Work (continued)

screws. Push the sled through the saw to make a kerf in the sled and to saw off the nose of the speed square. Now you're ready to cut perfect miters.

—Benjamin Retzinger, Mountain Home, Idaho

Quick tip: A plastic paint-roller tray makes a great screw-sorting device. Just pour that jar of randomly sized screws into the shallow end and, using a paint stir stick as a spatula, flick the screws you need into the deep end. When you're done, just pour the contents of the tray back into the jar.

—John Martin, Racine, Wis.

Separating the lid from a box

Many boxmakers like to glue up the box body and lid in one piece and then separate the lid from the box on the tablesaw later. The usual recommended procedure for this (recently echoed by Lon Schleining in his article on box joints in *FWW*#148, pp. 60-63) is to set the tablesaw blade height to just less than the box-wall thickness and make four tablesaw cuts around the box. This leaves the lid attached by a thin wooden web, which you then cut away with a handsaw.

Here is another method that I believe is just as safe, faster and works flawlessly every time. First set the tablesaw blade height to cut through the box wall. Then cut one side and both ends free on the tablesaw. Before making the fourth cut, clamp a thin filler piece into the kerf made by the first three cuts—I use a scrap of 1/8-in.-thick plywood. Place the plywood in the kerf and tighten

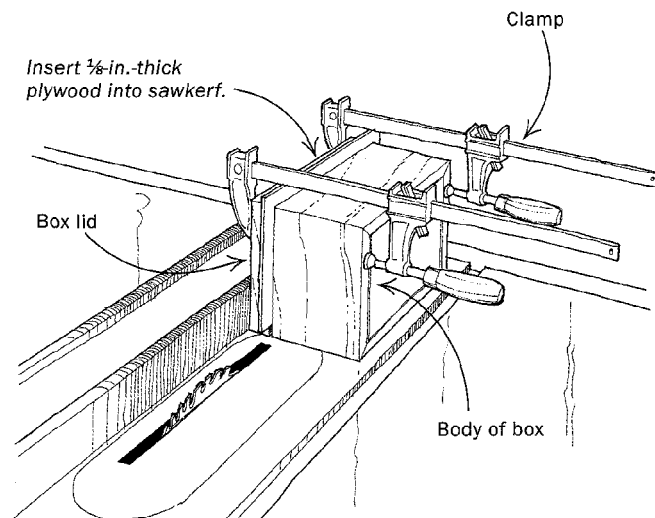

two hand clamps across the box to squeeze the plywood in place. With that done, you can safely make the fourth and final cut.

—Eric Kudell, Irvine, Calif.

Quick tip: I save a little time in my shop by adding two or three sheets of sandpaper at a time to my palm sander. When the first piece wears out, I simply rip it off and continue sanding with the next sheet.

—Chris Forgacs, Green Bay, Wis.

Methods of Work

EDITED AND DRAWN BY JIM RICHEY

Improved sawhorse

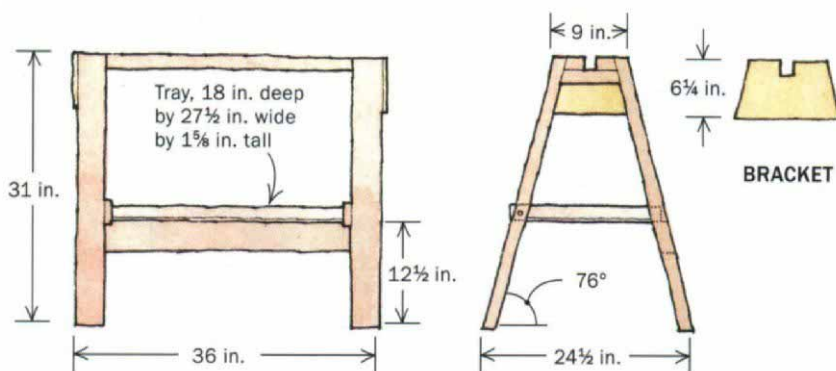
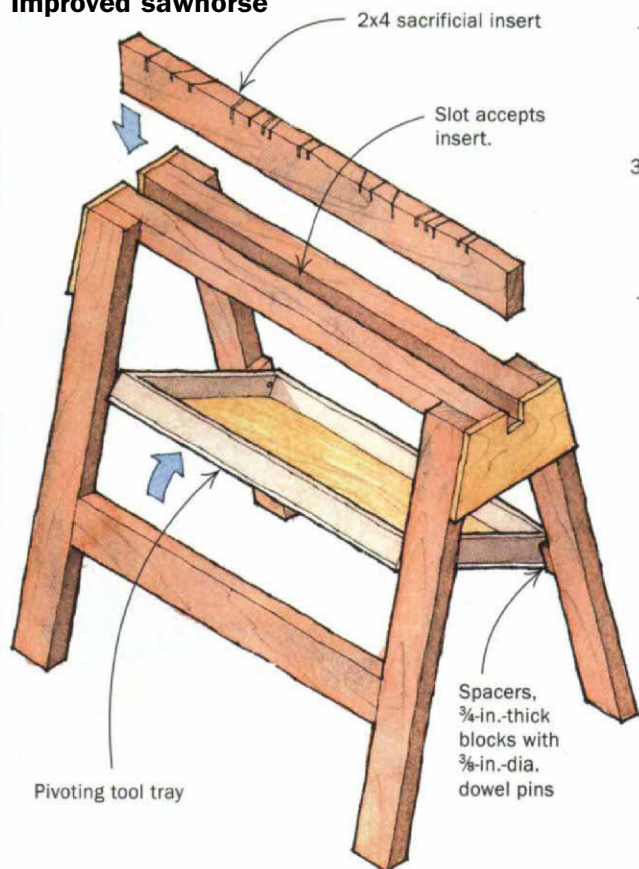

I've seen a lot of different designs for sawhorses, but none of them had all of the features I wanted. This one includes all of the improvements I was looking for: The horses are stackable, have a replaceable sawing insert and feature a flip-up tool tray.

Make the main structure of the sawhorse from 2x4s with plywood brackets (see the drawings above). The 1 1/2-in. slot through the top of the sawhorse allows you to stand a sacrificial 2x4 insert in the slot. Use this when you're cutting plywood so that you won't destroy the body of the sawhorse. When the insert is full of sawcuts, throw it away and cut a new one to replace it.

The tray is simply a plywood piece edged with 3/4-in.-thick stock. The tray pivots on dowel pins on one side and rests on a 2x4 stretcher on the other.

To make these horses even more

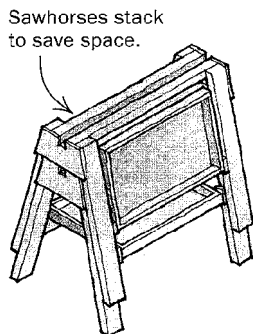

useful, I've made a 4-ft. by 8-ft. frame out of 2x4s. The frame slips into the slots of the sawhorses and supports thinner sheets of plywood better. I can also use the frame to transform two horses into a handy worktable.

—Kevin McLaughlin, Helena, Ala.

Cutting large-radius arcs with a router

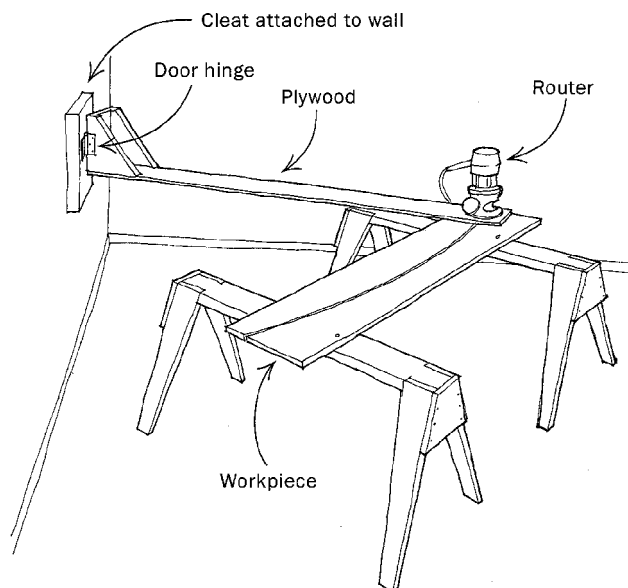

I recently needed to cut a 7-ft.-radius arc in a piece of plywood with a router. After thinking about it for a while, I came up with this



A reward for the best tip

This issue's best method came from Kevin McLaughlin, who comes to woodworking with many years of experience as a machinist and a mechanical engineer. He works for a firm that designs and builds robotic systems for manufacturers. His sawhorse design struck us as useful and original, although he says modestly that he simply assimilated and combined others he had seen into a new integrated model. Send us your best tip, along with any photos or sketches (we'll redraw them), to *Methods of Work*, Fine Woodworking, P.O. Box 5506, Newtown, CT 06470-5506.



Methods of Work (continued)

wall-mounted router-compass fixture that lets me work at a convenient height on sawhorses.

I started with a 7-ft.-plus length of $\frac{3}{8}$ -in.-thick plywood, 6 in. wide, and added a bracket on one end to provide a surface to attach an ordinary door hinge. I mounted my plunge router on the other end of the plywood, 7 ft. from the center of the hinge. I then secured the hinged end of the fixture to a cleat on my garage wall at the same height as the workpiece resting on the sawhorses. To cut the arc, I secured my workpiece on the sawhorses so that the 7-ft. arc was in the right location, and I made several passes.

—Lance D. Shields, Layton, Utah

Jointer knife-setting jig

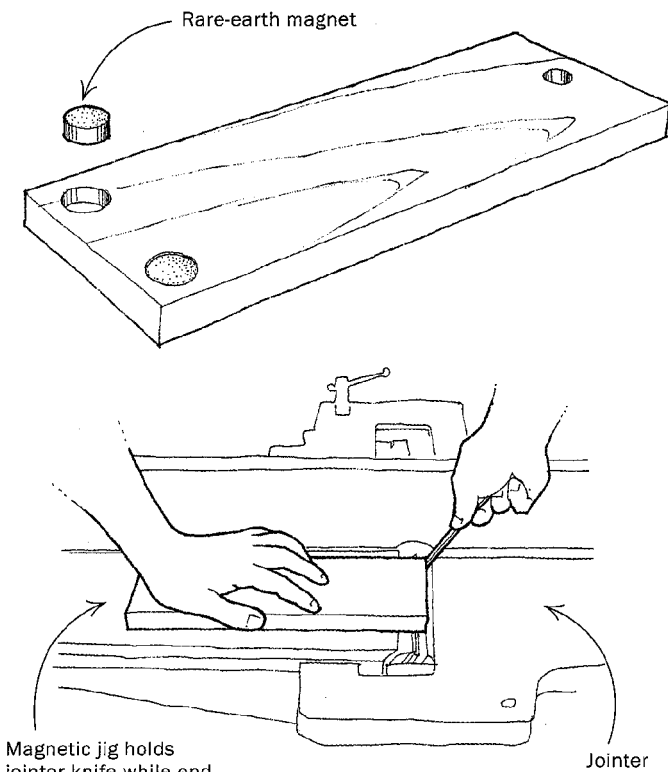

Magnetic jig holds jointer knife while end bolts are tightened.

This knife-setting jig is as simple as it gets. Inlay two large, round rare-earth magnets near the end of a length of a $\frac{3}{4}$ -in.-thick plywood scrap. Inlay the magnets just below the surface of the wood so that they will hold the knife without damaging a freshly honed edge. My jig, made for a 6-in. jointer, is about 4 in. wide and 12 in. long. To use it, place the jig on the outfeed table and hold it down with hand pressure. The magnets will hold the jointer blade at the outfeed-table height while you snug up the knife-holding bolts. When done, just slap the magnetic board against the outside of the jointer cabinet to store it.

—J. Prendergast, Surrey, B.C., Canada

Quick tip: You can reduce the time spent cleaning brushes by wrapping the wet brush with plastic wrap and storing it in the freezer. Remove the brush about 10 minutes before the next coat

and repeat the process when done. After applying the last coat, clean the brush or toss it.

—Jim Vasi, Williamsville, N.Y.

Compression chuck for the lathe

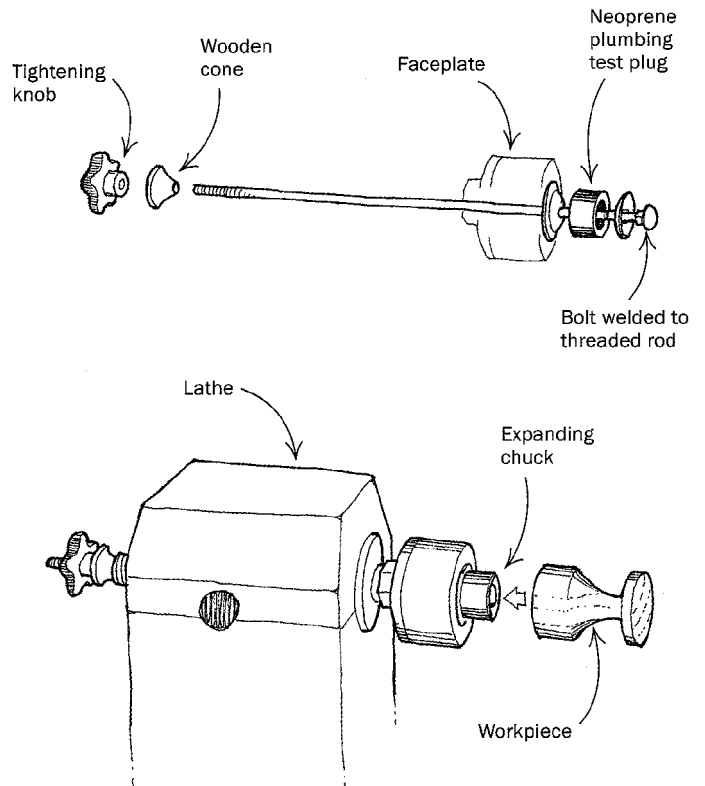

I turn a lot of small candle holders that have a $1\frac{1}{2}$ -in. recess in the top for a glass insert. After turning and parting off the holder, I like to reverse-chuck the piece and turn the bottom. The two traditional ways to reverse-chuck a workpiece are either to turn a wooden jam chuck or to use a metal four-jaw chuck. Both ways have problems. The jam chuck must be painstakingly turned to just the right size to work properly. The metal jaws of the four-jaw chuck will invariably mar the already-sanded workpiece.

This compression chuck for reverse chucking solves those problems. It is an adaptation of a plumbing test plug, a rubber expanding device commonly found in hardware stores. Test plugs come in several sizes—from $1\frac{1}{2}$ in. dia. to 4 in. dia.—to fit the inside of common plumbing pipes. You can also use a rubber expansion plug (also called a freeze plug) found in automotive-parts stores in a number of smaller sizes.

To make this chuck, screw a wooden scrap to a faceplate. Turn the scrap round and square off the face. Center-bore the wooden faceplate to fit the bolt in the test plug. Now remove the bolt from the test plug and extend its length by welding on a threaded rod. The lengthened bolt should extend entirely through the lathe headstock and out the other side by a couple of inches. On the outboard side, add a wooden cone and a threaded knob to tighten the chuck.

To use, turn the top part of the workpiece that includes a recess the same diameter as the chuck. Part the workpiece. Mount the expanding chuck on the headstock and slide the reversed workpiece

Methods of Work (continued)

onto the compression chuck. Bring up the tailstock with a ball-bearing center to support the workpiece and hand-rotate the workpiece to see if it is centered. Once the workpiece has been centered, tighten the knob to expand the chuck and create a firm hold. Start the lathe slowly and work up to speed, making sure the workpiece is revolving accurately. You can now turn the bottom of the workpiece with ease.

One word of advice: Be careful not to overtighten the chuck with a thin-walled piece, such as a goblet, because the pressure may split the wood.
—James Meier, Batavia, N.Y.

Centering raised panels with rope

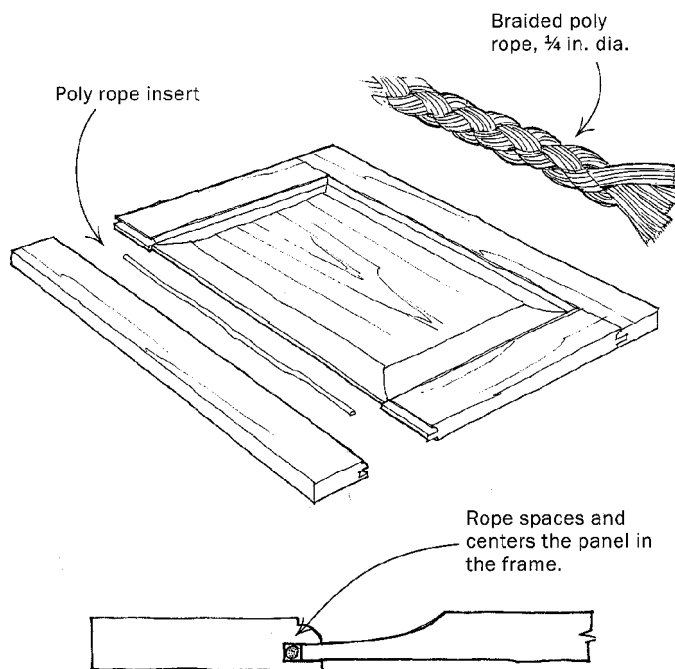

The shaper cutter I use to make stiles and rails for raised-panel doors cuts a 1/4-in.-wide panel groove that is 3/8 in. deep. I like the resulting joint because it has lots of gluing surface that makes a strong joint on the door. However, the cutter that bevels the edges of my raised panels cuts a flat area (tongue) on the edge of the panel that is only 3/8 in. deep. The mismatch of the 3/8-in. tongue to the deeper 3/8-in. slot could permit the panel to slip off center within the door frame.

To solve this problem, I make inserts from 1/4-in.-dia. yellow braided poly rope—the kind that is available at most hardware stores. I cut short lengths of rope and insert a piece into the groove of each stile and rail prior to assembling the door. The rope keeps the raised panel centered during glue-up, prevents the panel from rattling when the door is slammed and allows seasonal movement of the solid-wood panel.
—Don Warner, Lakewood, Colo.

Milk-carton storage system

To make a simple and convenient storage system for nails and screws, simply cut an opening in the back of a 1-qt. or a 1/2-gal. milk container. Leave a 1/4-in. strip of cardboard around the opening

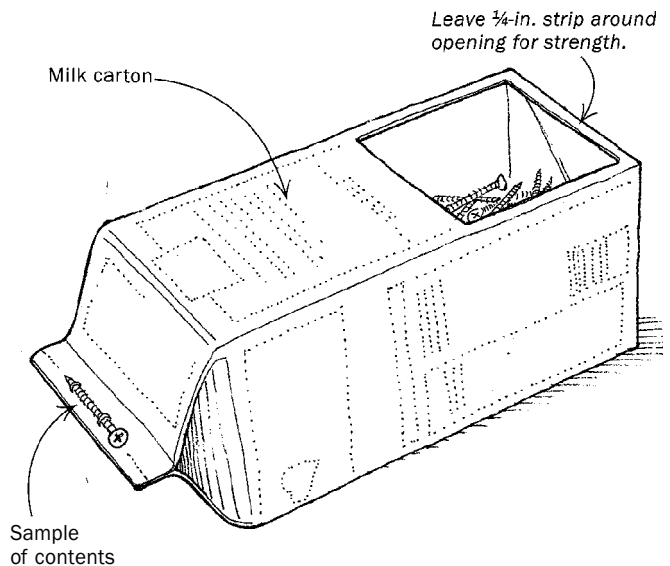

for strength and fasten a sample of the stored item to the top lip of the container to indicate the contents. The containers are sturdy, stackable and very economical of shelf space, and the contents are readily accessible.
—Don Anderson, Sequim, Wash.

Pipe-clamp rack

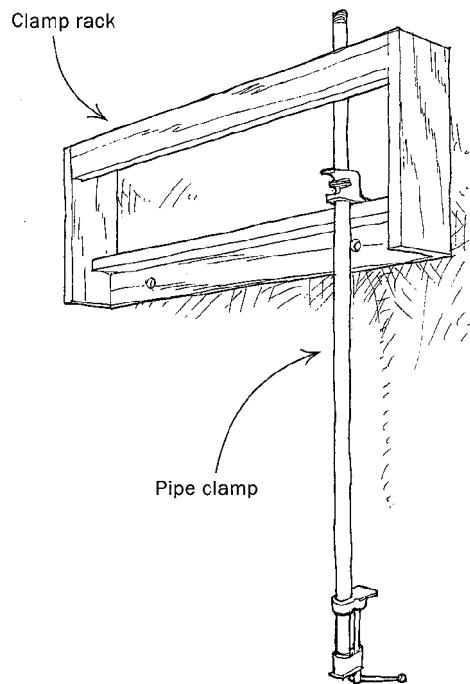

This simple rack not only stores clamps securely, but it also allows you to remove them quickly with just one hand. Simply grab a clamp and pull it toward you. Gravity helps the clamps stay put.
—Roy H. Hoffman, Oriental, N.C.

Methods of Work

EDITED AND DRAWN BY JIM RICHEY

Flared chisel for dovetail sockets

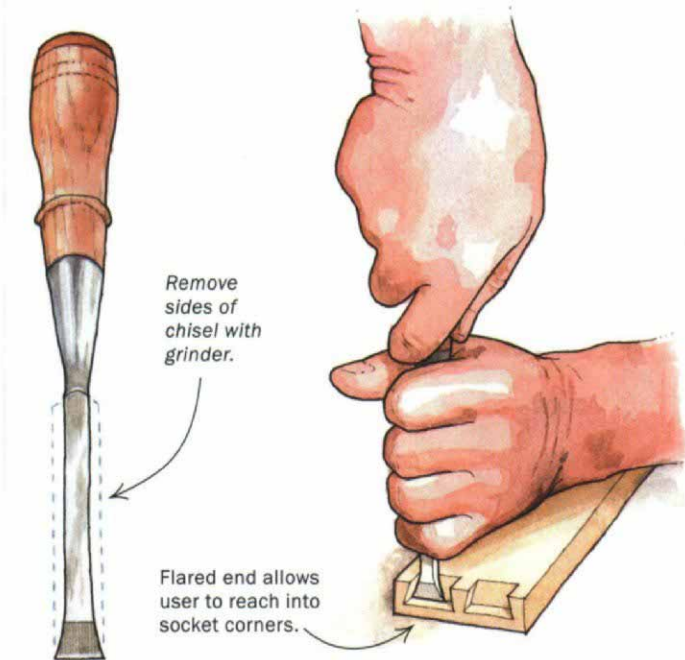

When I began making half-blind dovetails, I found it difficult to pare the deepest corners of the tail sockets with a regular chisel. So I made a special flared chisel for that purpose by grinding the edges off a regular $\frac{5}{8}$ -in. paring chisel. The flare at the cutting end should be a bit steeper than the dovetail angle so that you can easily get the tool into the corner of the socket.

You can use a bench grinder to remove the metal, but be sure to dip the chisel in water frequently to keep the cutting edge from overheating. It takes some patience to grind away all of the steel, but your reward will be a tool that makes an awkward job easier to do.

I try not to use the chisel for other tasks when a regular paring chisel will suffice. Each successive sharpening removes a bit of length from the chisel and therefore reduces the width of the flare. I should say, however, that I've been using and sharpening this tool for more than 20 years, and it still does the job well.

—Randy Leavitt, South Royalton, Vt.

Tool-moving dolly

All of my freestanding machines and my assembly table have wheels on the back legs and stationary legs with no wheels on the front. To move any of them, I use a two-wheeled dolly that is fitted with a vertical pin. This pin is $\frac{3}{4}$ in. taller than the angle-iron moving plates that are fastened to the front of each piece of equipment.

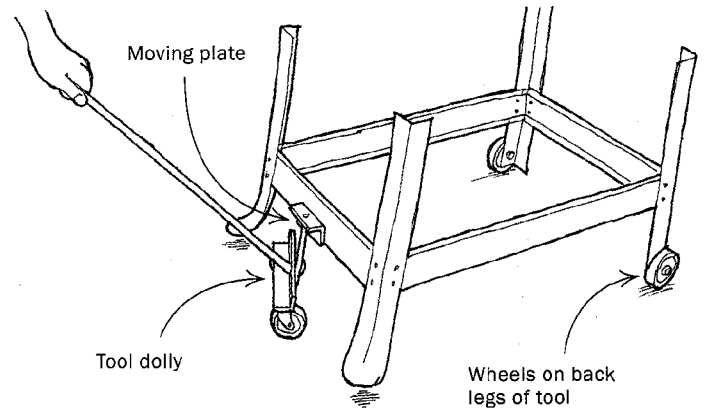

Each plate has a hole in the top that fits the pointed top of the dolly pin. I simply roll the dolly under the moving plate, engage the pin in the hole, and then push down on the dolly to lift the stationary front legs off the floor. I can then easily move the equipment anywhere in the shop.

—Rolland G. Kublmann, Canon City, Colo.

Shopmade compass plane

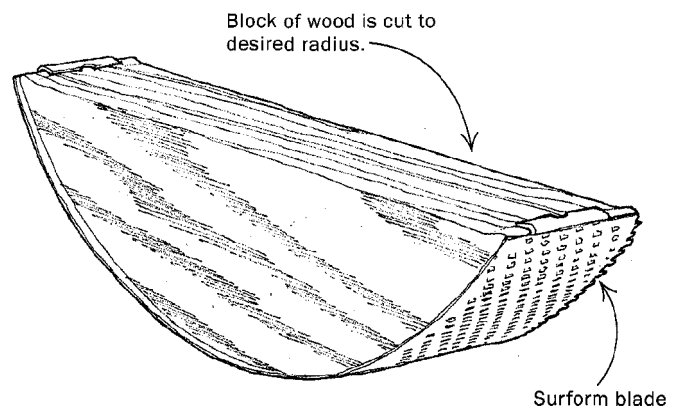

When I needed to smooth a roughsawn large-radius curve, I devised a custom compass plane using a shaped wooden block and a commonly available Surform tool blade. To make the tool, cut the desired radius in a scrap of 2x4. Then wrap the Surform blade around the block and mark where the end clips fall. Carefully cut the block to length, shaping the corners at an acute angle so that the end clips will hook over them. Now bend the blade and slip it



A reward for the best tip

Randy Leavitt is a seventh-generation Vermonter, a custom furniture maker and a musician. His shop is located in an old railroad freight station, and he plays the violin there every Thursday night in a band called *Damaged Freight*. His custom-ground chisel designed to clean out the bottom of half-blind dovetail sockets is a good example of how good tools are often made better out of necessity. Send us your best tip, along with any photos or sketches (we'll redraw them), to *Methods of Work*, Fine Woodworking, P.O. Box 5506, Newtown, CT 06470-5506.



Methods of Work (continued)

onto the block. The tool is quick to make, inexpensive and adaptable to a wide range of curved workpieces. I might also add that it is much easier to use on end grain than either a regular compass plane or a spokeshave.
—*J.K. McCoy, Kingwood, Texas*

Dog-wire clamp rack

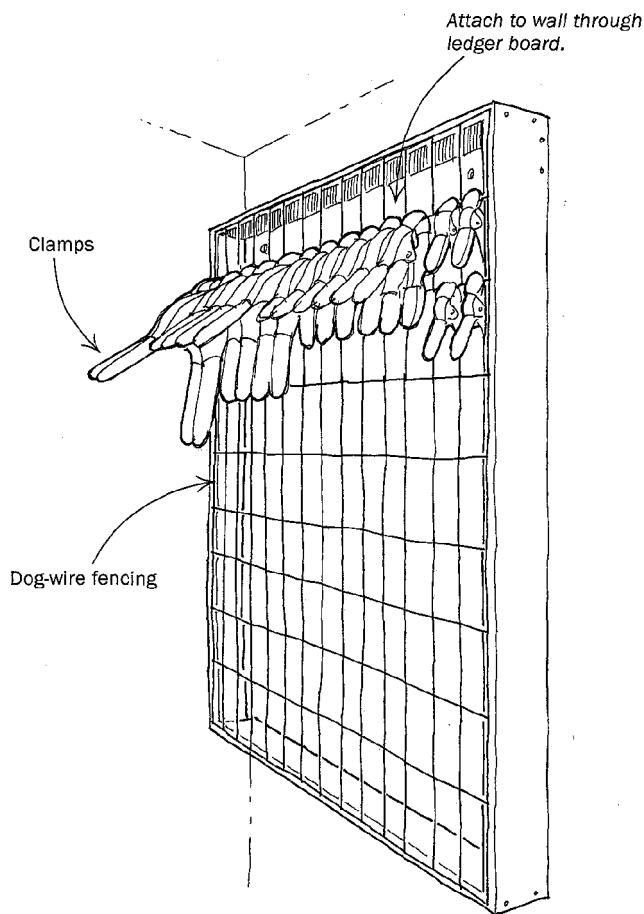

This simple and efficient clamp rack holds a large number and variety of woodworking clamps in a small space. The clamps can be easily hung from it whether they are open or nearly closed.

The key to the design is the use of a fencing material that the locals around here call dog wire—a heavy, 12 gauge grid material that easily supports the weight of the clamps. The grid also keeps the clamps segregated for easy attachment and retrieval. The frame is a simple 1x3-pine box with a ledger board at the top to provide a place to bolt the unit into wall studs.

—*Bob Zajicek, Marietta, Ga.*

Making a segmented column on the router table

I recently needed to make a large coopered oak column that was 12 in. dia. by 4 ft. long. Because these dimensions exceeded the capacity of my lathe, I devised a method for making the cylinder on my router table.

First, I glued up the coopered cylinder and removed most of the waste from the corners with a power plane. Then I screwed a plywood disc to each end and drilled centered holes in the discs

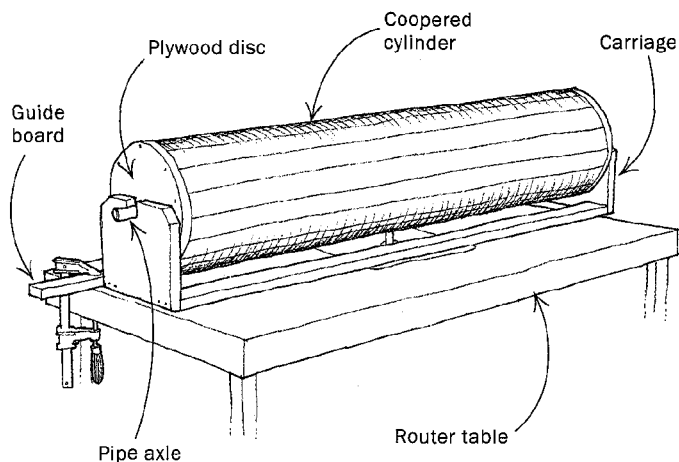

through which I placed a 1 1/4-in.-dia. iron pipe to serve as an axle. To hold the coopered column in place, I built a carriage with up-rights on each end that kept the rough cylinder suspended so that it just cleared the top of my router table. I also clamped a guide board to the router table to keep the cylinder centered directly over the router bit.

By rotating the cylinder over the router bit as I gradually advanced the carriage across the table, I was able to turn a perfect cylinder that required only moderate sanding.

—*Caleb Carlson, Sandpoint, Idaho*

Modifying a grinder to sharpen carving gouges

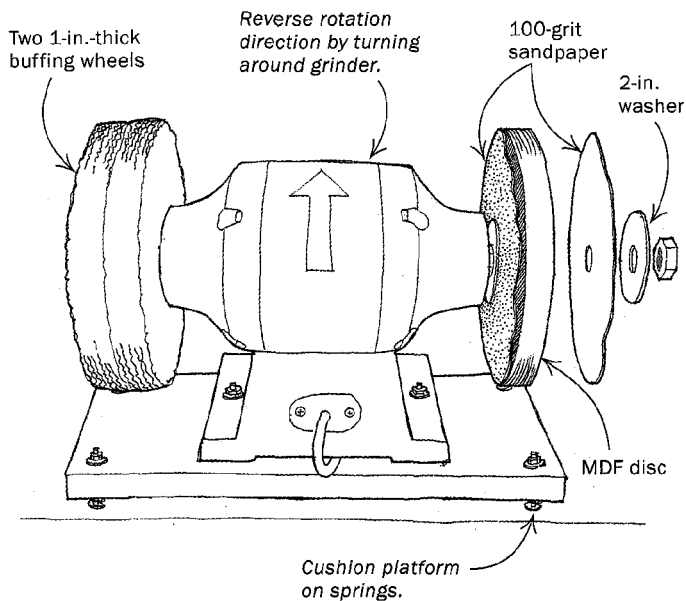

To sharpen wood carving chisels and gouges, start with a common grinder motor and turn around the grinder so that the wheels rotate away from you at the top, which will give you much more control. Mount the grinder on a platform supported by four springs to remove all vibration. Mount a plywood sharpening

Methods of Work (continued)

wheel (described below) on the right side of the grinder and sandwich two 1-in.-thick cloth buffing discs on the left side to make an oversized buffing wheel.

To make the sharpening wheel, laminate plywood to produce a 6-in.-dia., 1-in.-thick disc. If you don't have a lathe, simply saw the disc to rough shape on a bandsaw, mount it on the grinder and turn it to final shape in place. Mount a disc of fine sandpaper (150 or 180 grit) to each side of the disc and a ribbon of sandpaper to the rim. Don't glue the side pieces to the wheel: They should be allowed to float on a film of air as the wheel rotates. This allows you to apply a very gentle pressure with the gouge, thereby removing the risk of overheating the blade being sharpened. After sharpening the tool on the wheel, move to the cloth buffing wheel to polish and hone the edge.

—Alex Cameron, Golden Grove, South Australia

Improved router-chuck wrench

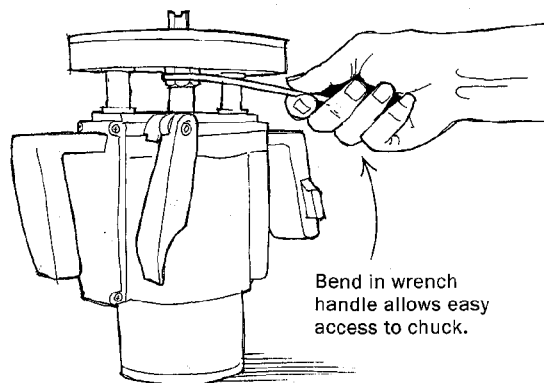
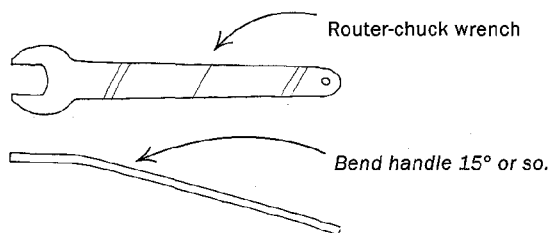

That cheap chuck wrench that comes with your router is an awkward knuckle-banger to use. A low-cost, low-tech remedy to this problem is to clamp the jaw end of the wrench in your vise and bend the handle about 15°. This should angle the wrench just about right to reach in through the opening in the router base.

—Fred Tabshey, Omaha, Neb.

Turning deep bowls

The problem with turning deep bowls is that as the turning gets deeper the distance between the tool rest and the cutting end of the turning tool increases. It becomes more and more difficult to stabilize the turning tool with one hand while trying to compensate by pushing down harder with your other hand, which often causes the turning tool to jam.

I solved this problem by adding a second tool rest against which

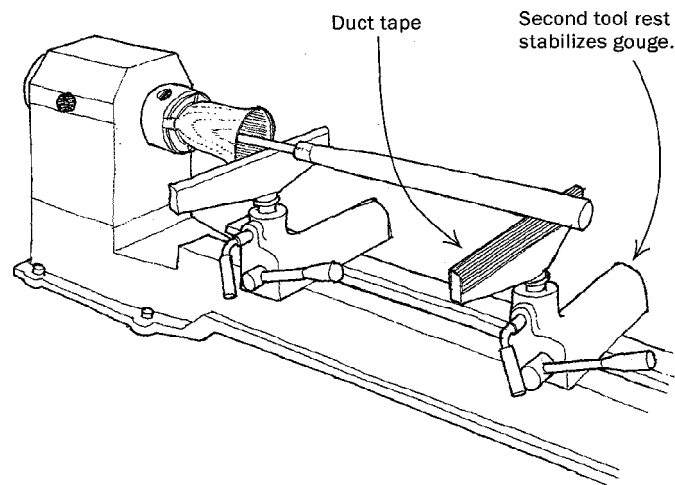

I can firmly hold the handle of the turning tool, as shown in the drawing above. I cover the second tool rest with duct tape to minimize nicks and dents in my tool handles. With this setup I can hollow out vessels like a pro.

—Robert P. Cromwell, Royalston, Mass.

Versatile shop aid

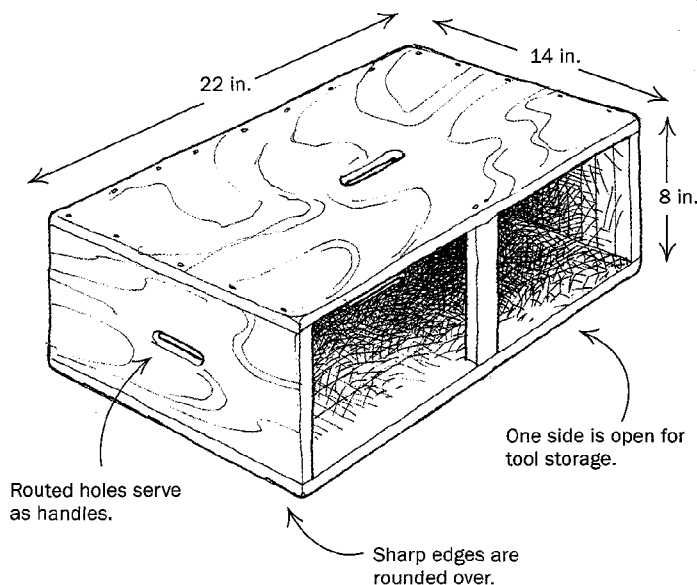

Here's a simple shop aid I made many years ago that I continue to use almost every day. I drill, sand and saw on it. I use it to support panels at the right height below my bench vise. I stand on it to work on an 8-ft ceiling. I carry tools in it to a job site and use it there as a workbench. And I sit on it to eat my lunch.

I made the box out of some scrap 3/4-in.-thick plywood, rounding the edges to keep splinters out of my hands. The drawing above shows the dimensions that I have found useful for my 5-ft. 10-in. frame.

—Paul Darnett, Phoenix, Ariz.

Methods of Work

EDITED AND DRAWN BY JIM RICHEY

Adjustable jig for cutting tapers

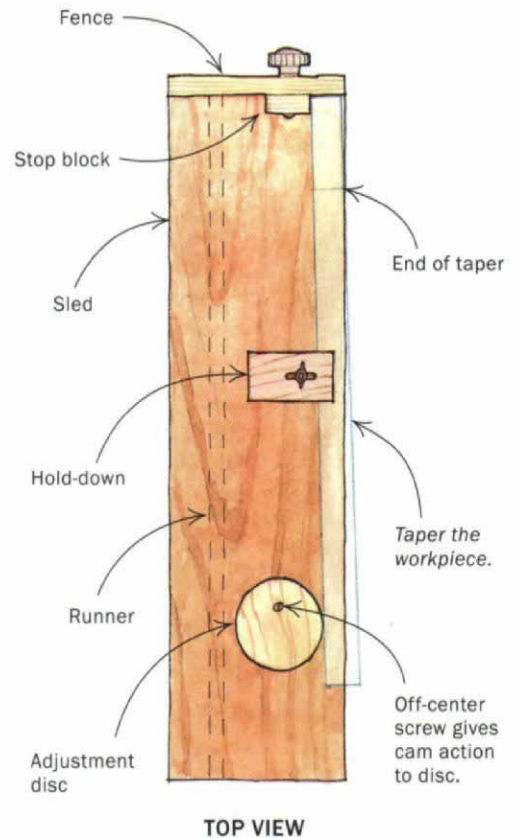

This adjustable tapering jig for the table saw is easy to make and sets up in a flash. It replaces all of those dedicated one-time jigs, and it's more reliable than a jig that puts the blank directly on the tabletop.

The fixture is basically a sled with a runner on the bottom that slides in the miter-gauge slot. This arrangement ensures that the edge of the sled is snug against the blade every time. No fence adjustments are required. The jig consists of five main parts: The sled, the runner, a fence at the front that incorporates an adjustable stop block, a hold-down and a cam-action disc at the back that sets the taper angle.

To make the fixture, first cut the 30-in.-long sled from $\frac{3}{4}$ -in.-thick plywood and an equally long hardwood runner to fit the miter-gauge slot. Put the runner in the miter slot, raise the sawblade all

the way up and, with the edge of the sled square against the blade, nail two brads through the sled into the runner to attach it temporarily. Remove the sled, invert and secure the runner with four countersunk screws. Now attach the fence assembly to the front and the disc to the back. Secure the 3½-in.-dia. disc with a wood screw $\frac{3}{4}$ in. off center that creates a cam action that will vary the depth of the taper cut.

To use the jig, first adjust and lock the stop block on the fence to set where the taper will end. Then, with one end of the workpiece against the stop block and the other end against the disc, turn the disc until the finished width of the leg is in line with the edge of the sled. Readjust both stops, if necessary, until everything is perfect. Now push the workpiece blank against the two stops, lock it down and cut the taper. Turn the blank 90° clockwise and make a

A reward for the best tip



David Hastings is retired from a 42-year career of many different business ventures, but he remains active with other pursuits. Woodworking is only one of his hobbies. He also plays tennis and races his 1951 MG roadster. In addition to that, he's the president of a non-profit adult education program near his home in suburban Philadelphia, and he keeps busy by taking woodworking and finishing courses given by many of the people who write for *Fine Woodworking*. Send us your best tip, along with any photos or sketches (we'll redraw them) to *Methods of Work*, *Fine Woodworking*, P.O. Box 5506, Newtown, CT 06470-5506.

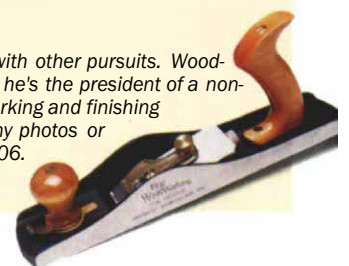

Methods of Work (continued)

second cut. This will produce a leg that is beautifully tapered on two sides. To make a leg that is tapered on four sides, you will need to readjust the disc for cuts three and four.

—David Hastings, Haverford, Pa.

Shop-built sharpening carriage

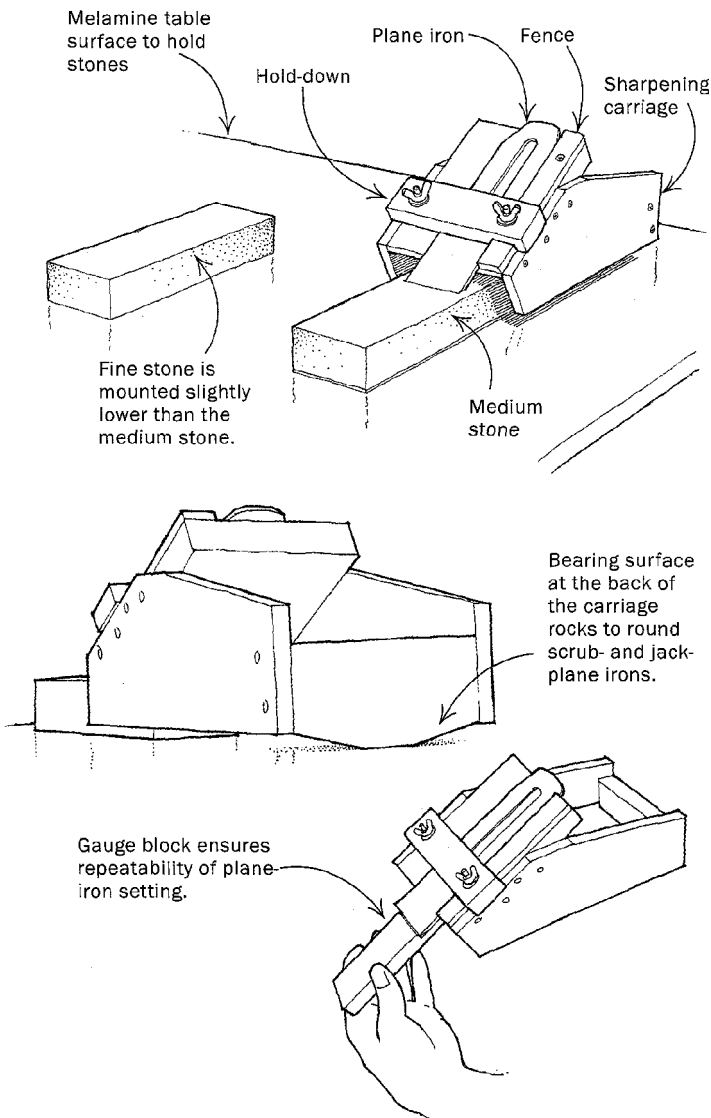

The main difficulty I had in sharpening plane irons and chisels was maintaining a consistent sharpening angle. I could get the tools sharp enough initially, but I didn't like the concave bevel that would result. Also, the bevel tended to get higher and higher as time went by, eventually requiring a serious session on the grinder.

So I finally made this sharpening carriage that solved my problems when I used it with a carefully set up stone table. The stone table is fitted with two stones: a medium stone to restore the tool's main bevel and a fine stone to hone a final microbevel. The trick is to mount the fine stone $\frac{3}{16}$ in. lower than the medium stone. This automatically produces a microbevel of 1° without moving the blade in the jig.

This sharpening setup has other advantages. It produces a flat main bevel rather than the weaker concave bevel that is produced on a grinder. Also, because the jig straddles the stone, it eliminates the oily mess created by a roller riding on the stone.

The carriage is simple to make. Cut the sides from $\frac{3}{8}$ -in.-thick plywood and the other pieces from scrap hardwood. Lay out the front ramp of the fixture at your preferred bevel angle (30° in my case). Add an alignment fence for a plane iron and a hold-down device on the top of the angled ramp. One optional feature to include is a narrow bearing surface at the back, as shown in the drawing. This allows you to rock the plane iron from side to side to create a rounded cutting edge for scrub and jack planes.

I made up three versions of this jig: One for 30° plane irons, another for 30° chisels (with the bed cut away to accommodate the handles) and yet another for 25° paring chisels. Of course, dimensions and angles can be adjusted easily to suit your preferences and individual tools.

To make the stone table, mount the two stones in routed troughs of different depths in a piece of melamine. My stones are 7 in. apart and 11 in. from the front edge. The medium-grit stone is $1\frac{1}{16}$ in. high, and the fine stone is $\frac{1}{2}$ in. high.

To use the jig, adjust the plane iron in the jig for an angle of 30° on the fine stone. Make a gauge block to ensure repeatability of the blade projection. Starting with the plane iron on the medium stone, move the carriage back and forth until you have restored the main bevel. Then, without adjusting the plane iron, move the carriage to the fine stone and hone a short microbevel.

—Bruce Tombleson, Bussiere Galant, France

Sawhorse crosscutting aids

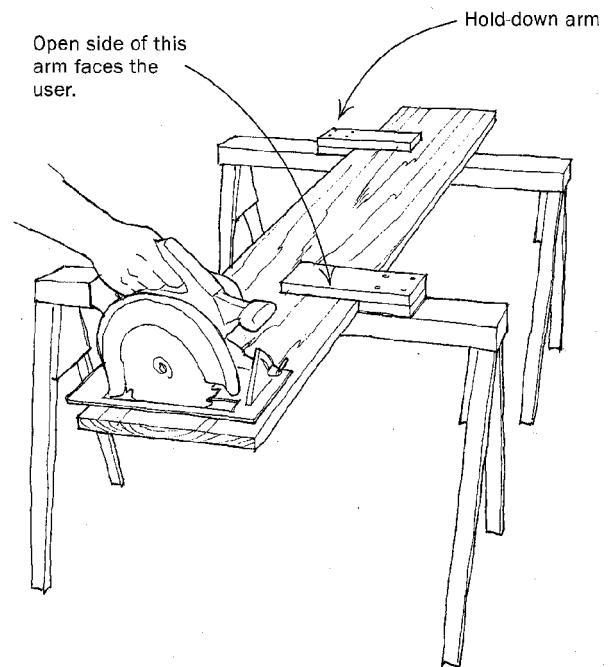

These two hold-down arms are mounted on sawhorses to enable clamp-free crosscutting of long boards. To make them, screw to-

Methods of Work (continued)

gether two arms from scrap offcuts the same thickness as the stock to be cut. Mount the arms to your sawhorses with a thin shim under each one, so that the workpiece will slide under the arms easily. The arms should be mounted in opposite directions—open to you on the near end and closed on the far end (as shown). Properly set up, these arms will lock the board in place and prevent it from pivoting or lifting.

—Louis Pennacchia Jr., Syracuse, NY

Quick tip: To keep dust and fog off the lenses of your glasses, spray with a product called Rain-X and wipe off. It works better than anything else that I have tried. The product is available wherever car parts are sold.

—Richard Dininny, Elmira, NY

Wooden cabinet latch

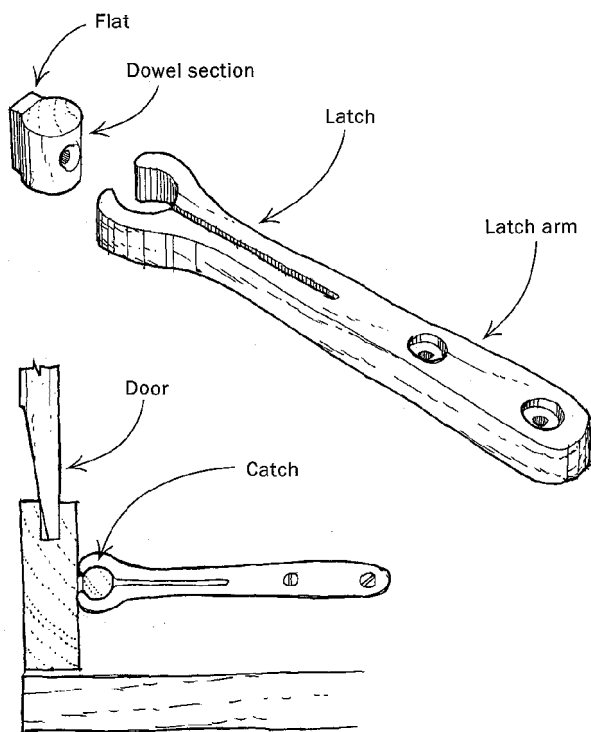

I first made this wooden latch several years ago when I couldn't use the traditional turn latch on a reproduction antique cabinet. The latch has functioned so well over the years that I have begun using the design in other cabinets. The body of the latch is a 5-in.-long piece of 1/2-in.-thick walnut, a wood I chose for its shock resistance. It is attached to the top or bottom of the case interior. The length of the slot, which gives the latch its spring action, is about half the total length of the body. The width of the opening can be modified for the amount of tension desired. The catch is just a wooden dowel with a flat piece glued to it.

—Bernard Resh, Lancaster, Pa.

Jig for routing lock-miter joints

Here is a simple jig that enables the safe and accurate cutting of lock-miter corner joints that require both a horizontal and a vertical pass over the router bit. Cutting these joints by holding boards

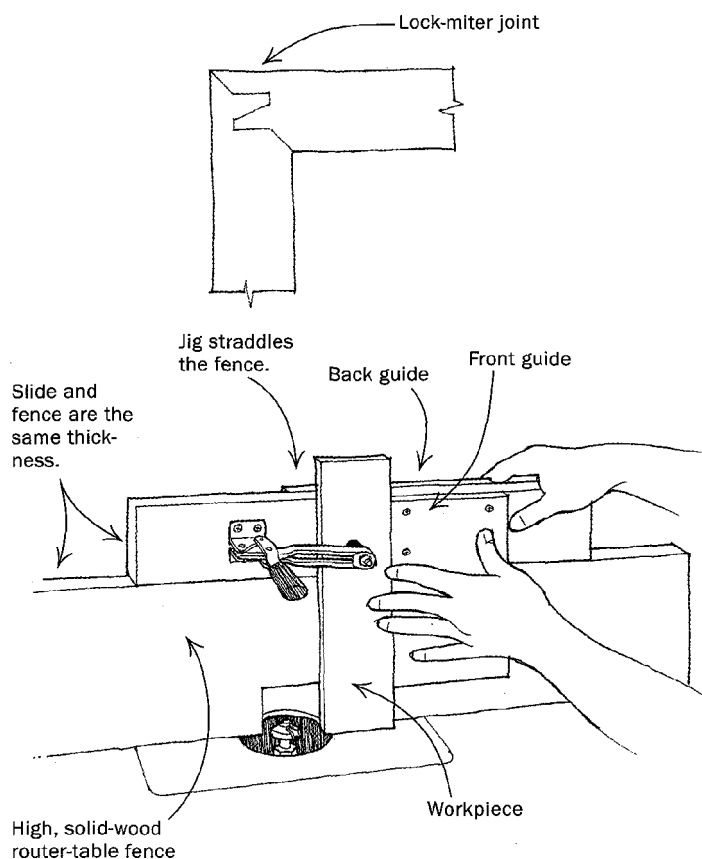

in a vertical position with just your hands is a daunting task. The operation can be dangerous, and the results can be inaccurate.

This jig requires a sturdy, extra-high router-table fence. Mine is 6 1/2 in. high and more than 1 1/2 in. thick. The jig carriage consists of an 18-in.-long slide, cut from the same stock as the fence to ensure identical thickness. The front and back guides are 5-in. by 8-in. chunks of 1/2-in.-thick plywood. One De-Sta-Co clamp holds the workpiece tightly against the jig. Because the carriage fits snugly over the top edge of the fence, only light hand pressure is needed to hold the lower part of the board against the fence as it engages the bit. You can accommodate workpieces of different widths by moving the clamp.

—Norman Ellis, Tuscaloosa, Ala.

Quick tip: When using a hand scraper, wear cotton gloves with PVC dots. The gloves effectively dissipate the heat that is generated, give you a better grip and keep your hands dry and cool.

—W.D. Timberlake, Houston, Texas

Miniature shaving horse

For those chair makers who like to work standing up or who don't have space for a full-sized shaving horse, this little version (see p. 20)—made to be held in a bench vise—is both compact and portable. To use it, simply clamp the keel in the bench vise, push back the lever arm to raise the upper jaw of the jig and lower it on to the workpiece. The spring mechanism closes the jaw automatically and provides gripping force.

The key feature of the horse is a 3/8-in.-dia. steel shaft that goes

Methods of Work (continued)

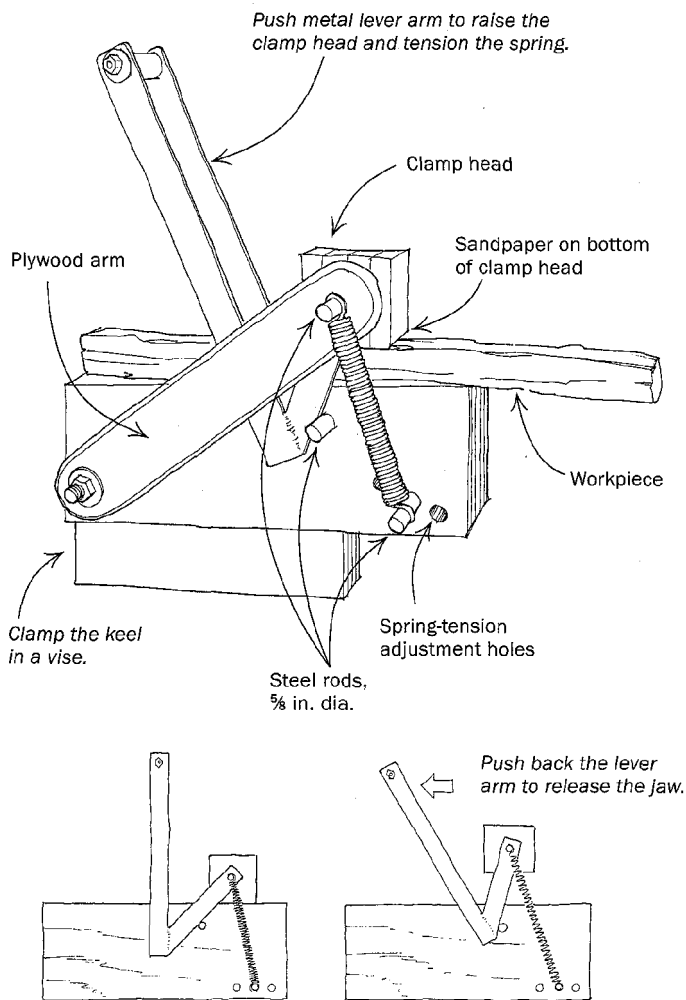

through the wooden arms, the metal lever arms, the clamp head and the springs. A second shaft through the body of the horse provides a fulcrum point for the lever arms. A third shaft provides an attachment point for the springs and can be moved to increase or decrease the clamping force. Clamping pressure can also be adjusted by using stronger or weaker springs. The clamp head has sandpaper on the business side to enhance the grip. You could also add a strip of sandpaper to the top edge of the body for an even better grip.

All of the wooden parts of the jig were made from $\frac{3}{4}$ -in.-thick Baltic-birch plywood. The lever arms were welded up from 1-in.-wide, $\frac{1}{8}$ -in.-thick steel.

—Louis Mengoli, La Mesa, Calif.

Quick tip: Make your furniture templates from clear Lucite plastic. This allows you to move the pattern around the blank until you find the perfect grain pattern to complement the design.

—Robert McElfof, Grants Pass, Ore.

Tie-down band clamp

For edge-banding round tabletops and clamping odd shapes, I use a modified cargo tie-down as a band clamp. Tie-downs are heavy nylon straps with a ratchet on one end used by truckers to secure

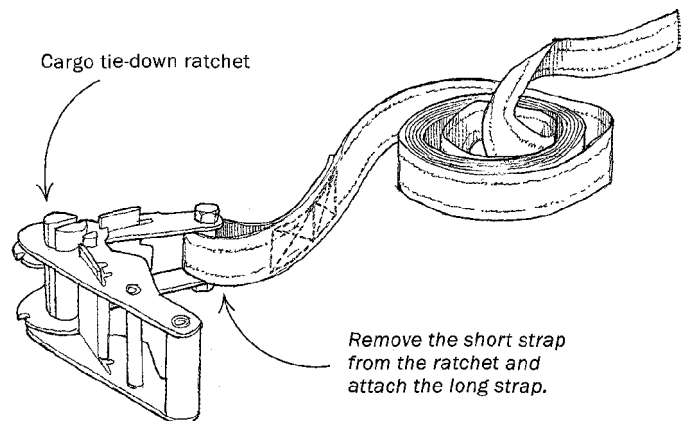

their loads. These tools are commonly available in several sizes at auto-parts stores.

When purchased, the tie-down comes in two parts: the ratchet with a short strap attached and a separate longer strap. To use as a band clamp, remove the short strap from the ratchet and replace it with the long strap.

—Jim Wallace, Cedar Park, Texas

Quick tip: When I connected my new saw to a dust-extraction system, the amount of air leaking through various holes and slots in the saw's base was unacceptable. So I bought a flexible magnetic sheet—the kind used on car doors for advertising—and snipped out the necessary shapes with scissors to seal off the unwanted air leaks. Now the dust collection works much better, and I can easily remove the seals when necessary.

—Ruud Joling, Purmerend, The Netherlands

Pattern cutting on the bandsaw

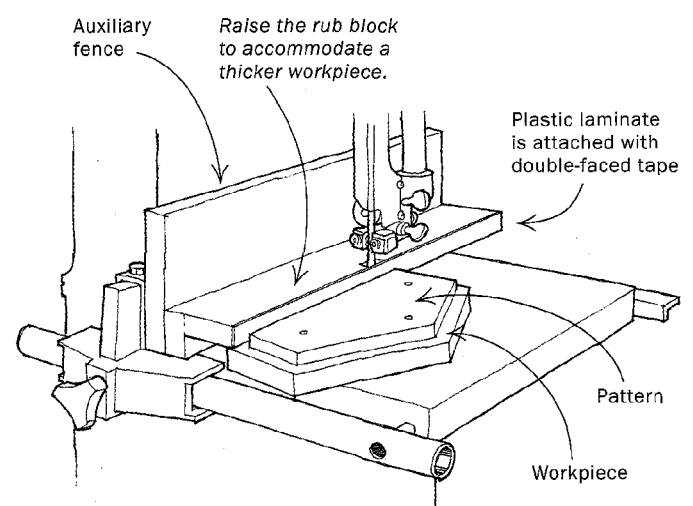

For years I've used my tablesaw for pattern sawing using a technique described in *FWW*#47, p. 54. Recently, however, I became nervous about using the tablesaw technique when I had a workpiece that was only 2 in. on one side. It just didn't feel safe. So I

Methods of Work (continued)

modified the pattern-cutting fixture for use on my bandsaw. The fixture is quite simple to construct (see the drawing on p. 20).

It is a good idea to construct the fixture so that the inside cutting edge of the blade is a standard distance from the outer edge of the fixture— $\frac{1}{2}$ in. in my case. This allows you to cut the hardboard pattern pieces $\frac{1}{2}$ in. smaller than the desired final dimensions. One important part of the fixture is a strip of plastic laminate held in place with double-faced tape. This provides a continuous surface against which the pattern can be run, avoiding any snags at the cutout around the sawblade.

—Barnett C. Howard, Sisters, Ore.

Quick tip: Use flexible sewer hose designed for recreational vehicles for your 3-in. dust-collection pipes. The hose is fitted with twist locks for easy connection and can be purchased quite reasonably at RV supply stores.

—Earvin Ruddick, Westminster, Md.

Tablesaw extension with PVC rollers

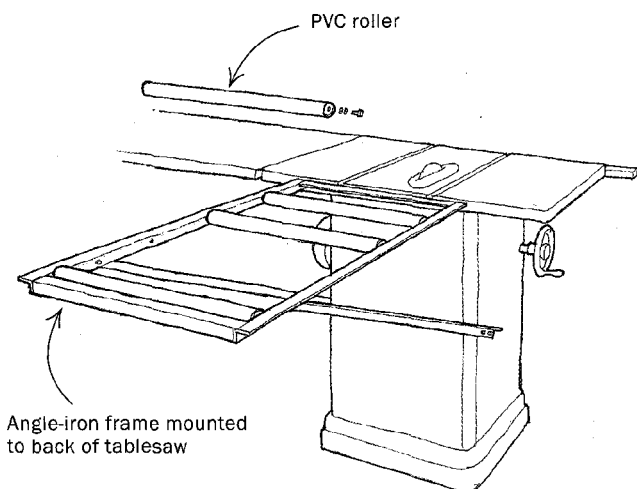

Angle-iron frame mounted to back of tablesaw

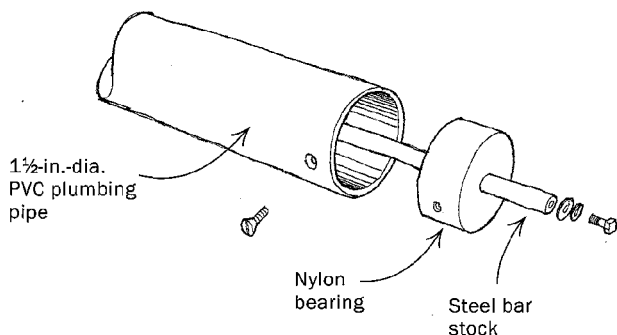

In a one-man shop, ripping sheet goods and long lumber is difficult. I decided to solve this problem by building a roller extension on the back of my tablesaw. When I discovered that the commercially available rollers cost \$26 each, I went shopping. For a few bucks I bought a 10-ft. length of 1½-in.-dia. PVC plumbing pipe, a short length of nylon bar stock, several lengths of ½-in.-dia. steel bar stock and some angle iron.

I made up four rollers by cutting lengths of the PVC and fitting

each end of the pipe with bearings made from the nylon bar stock. I made axles from the ½-in.-dia. steel bar stock and drilled and tapped holes in each end to attach the axles to the frame. I then made a cantilevered framework with angle iron and bolted the framework to the back of the saw as shown, so that the rollers are level with the top of the tablesaw. This extension has made the handling of large stock much easier, quicker and safer.

—Don Gilliem, Milford, Mich.

Replaceable insert for radial-arm saw

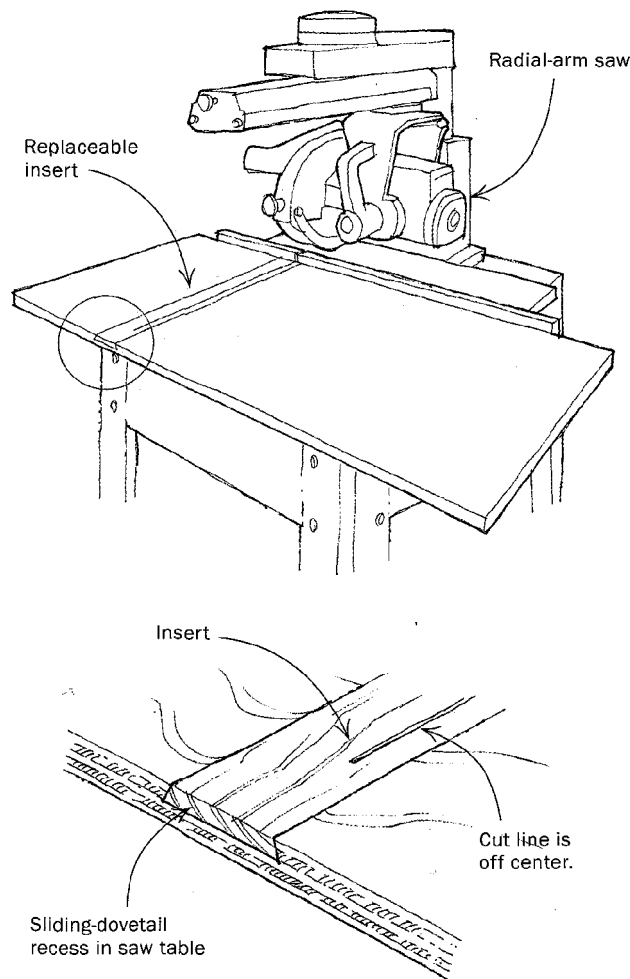

After a time the cut line on a radial-arm saw's table gets too worn to provide an accurate guide and a splinter-free backup for the cut. Yes, I could replace the front part of the table with a fresh piece of plywood, but this is not an economical solution.

So I devised this dovetail table insert that could be replaced as frequently as needed with little effort. The insert installs into a sliding dovetail where it requires no permanent attachment, and it can't lift out during the cut. I routed the insert's channel off center to the cut line of the blade so that a single insert can be swapped end for end and thus serve double duty. I used a router and a dovetail bit to rout the channel into the table and to bevel the edges of the insert.

—Millard B. Niver, Navarre, Ohio